

Perfect Edges. Flexible Machines.

HOMAG

Our edge banding machines

EDGETEQ S-380 | S-380 profilLine

YOUR SOLUTION







Perfect edges for discerning customers manufactured with flexible machines

Individual customer needs and preferences, sophisticated products and a wide range of materials – all factors which play a major role in today's woodworking industry. Here, production flexibility and efficiency are key – particularly for woodworking shops and medium-sized enterprises.

HOMAG offers unbeatable benefits and has a presence on the ground with international production plants and Sales and Service companies with around 6,600 staff members in over 100 countries around the world. Work with HOMAG to create a sharp competitive edge and security for your business in the long term.

YOUR SOLUTION

MORE: HOMAG.COM



CONTENT

- 04 All inclusive as standard
- 08 Series EDGETEQ S-380 | S-380 profiLine
- 16 Our unit modules
- 33 Workpiece return conveyors
- 36 EDGETEQ S-380 profiLine
- 38 Control with powerTouch
- 40 Technical data
- 42 HOMAG Life Cycle Services

All inclusive as standard

THE MOST IMPORTANT FEATURES OF THE MODELS. These series are characterized by their comprehensive equipment standard: Belt-type top pressure for precision workpiece guidance, optimized trimming tools for optimum chip disposal and perfect processing quality. Variable feed speeds in various performance categories for high productivity. All machines can also be extended. HOMAG machines EDGETEQ S-380 are energy-saving and environmentally friendly.

THE EDGETEQ S-380 PROFILINE offers additional processing units compared to pre-configured machine models and, in addition, can be freely equipped with units from our extensive modular range.

- **High-grade furniture with high edge quality**
- **More output through high availability**
- **Low energy requirement**
- **Outstanding economy**
- **Optimum cost-to-performance ratio**

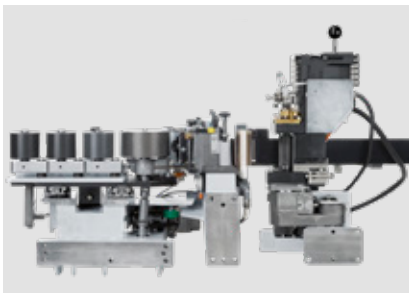

Gluing units – safe hot-melt glue application

HOMAG gluing units are ideal for a fast, positive-locking EVA and PUR glue bond. The heated glue roll provides an optimum glue temperature.

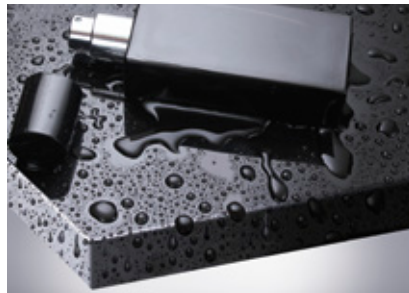

Edge banding with PUR

PUR adhesives are used by HOMAG on the same machines and with the same application units as EVA hot melt adhesives.



Zero joint technology with HOMAG airTec

The units are now equipped with a rotary air heater which makes the process significantly more efficient and quieter as well as saving resources.



Intuitive operation with powerTouch control system

Using the widescreen format multitouch monitor, you control machine functions by direct touch contact. The ergonomically optimized design and an array of help and assistant functions substantially simplify operation.



Belt-type top pressure

The top pressure beam made of steel with double V-belt forms the basis for outstanding quality, as it ensures that workpieces are ideally clamped for processing.



Multi-stage technology

For easy profile change by push button. Saves time and improves quality.

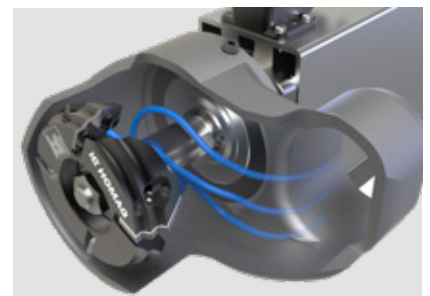

Controlled chip capture

The chips are extracted already in the interior and selectively directed to the extraction hood.

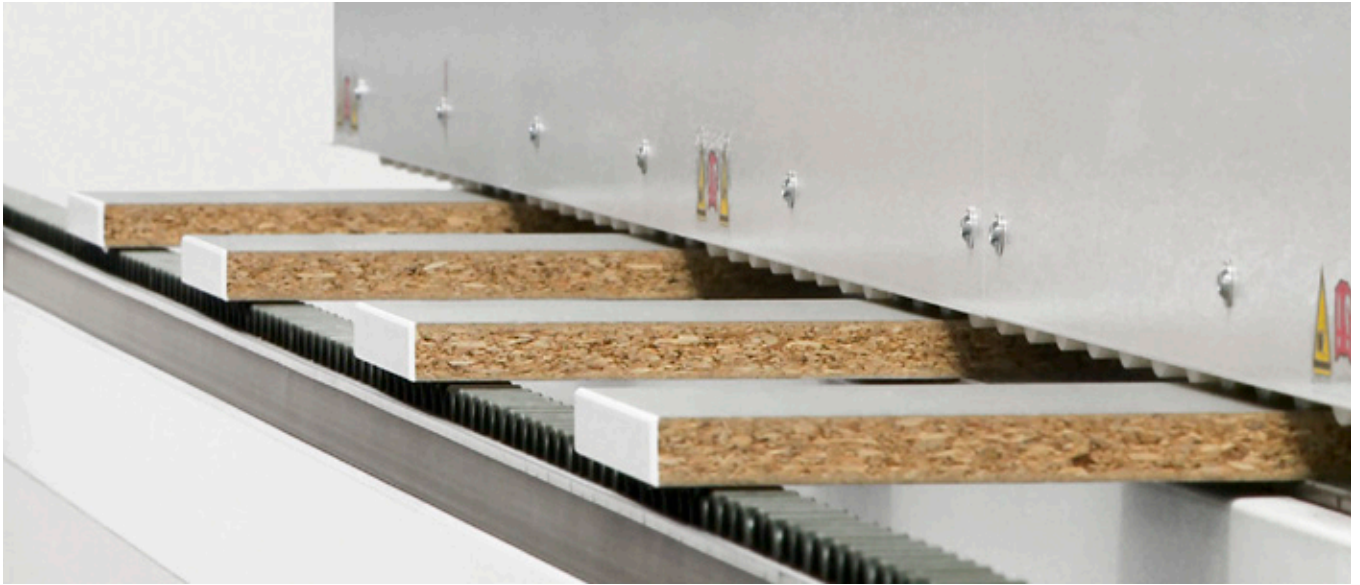

Material types | Edge parameters

High flexibility is achieved by processing all edge materials: 0.3 mm melamine, 3 mm PVC, 20 mm solid strips and veneer. For perfect high-gloss parts, important components such as the motor-driven top pressure and the automatic adjustment of the glue joint scrapers are used. Special tracing elements are ideal for machining of acute-angled or obtuse-angled parts or parts with hinge holes.



				a	b	c	d	e
	SOLID (mm)					0.4 – 12,0 (optional 0.4 – 20)		
	COILS (mm)		with b = 22: min. 60 with b = 40: min. 125		8 – 60	0.3 – 3.0	65	max. 30
	STRIPS (mm)					0.4 – 3.0 optional		



Higher output for your edge banding machine

Workpiece return conveyors of the LOOPTEQ series provide the ideal complement to the machines of the EDGETEQ series. The LOOPTEQ O-200 is ideal for small, narrow and medium-sized workpieces. LOOPTEQ O-300 is best suited for high material variety, from small and light up to large and heavy workpieces.





EDGETEQ S-380 Models 1650 FC | 1660 FGC | 1670 FGC: Setting standards in performance and quality

The basic machine is equipped with a precise gluing unit, a 2-motor snipping unit, a trimming tool and a profile trimming tool. A radius scraper, glue joint scraper and a buffing unit ensure a perfect finish. The high-powered motors of all the units ensure the unrestricted strength required for processing the broad product spectrum. To allow the optimum solution to be offered for every requirement, a joint trimming unit and

a tiltable grooving unit (model 1660 FGC and 1670 FGC) are available for the machines. With the optional Quickmelt gluing unit, optional workpiece gap optimization for even more effective production and the available separating and cleaning agents, this series is ideally equipped to cope with every conceivable requirement.



EDGETEQ S-380

Model 1650 FC

Feed speed: 8 – 18 m/min (20 optional)

- 1 Joint trimming unit
- 2 Gluing unit
- 3 Snipping unit
- 4 Trimming unit with pneumatic 2-point adjustment
- 5 Profile trimming unit
- 6 Profile scraper with quick-change heads
- 7 Glue joint scraper
- 8 Buffing unit

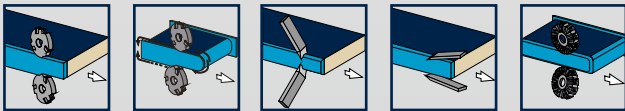

EDGETEQ S-380 – Model 1660 FGC

This model comes with the same equipment as Model 1650 FC plus a grooving unit.



EDGETEQ S-380 – Models 1650 HF and 1660 HF: Precision and performance for high-end requirements

The basic machine is equipped with a Quickmelt gluing unit, a 2-motor snipping unit, a trimming unit and a multifunctional profile trimming unit for corner rounding and flush trimming. A radius scraper and a buffing unit ensure a perfect finish. The high-powered motors of all the units ensure the unrestricted strength required for processing the broad product spectrum. To allow the optimum solution to be offered for

every requirement, a joint trimming unit and a glue joint scraper are available for these machines as standard. The Highflex series is characterized by its high level of automation and a comprehensive range of processing units. The high degree of flexibility enables adjustment to your specific needs and guarantees optimum edges.

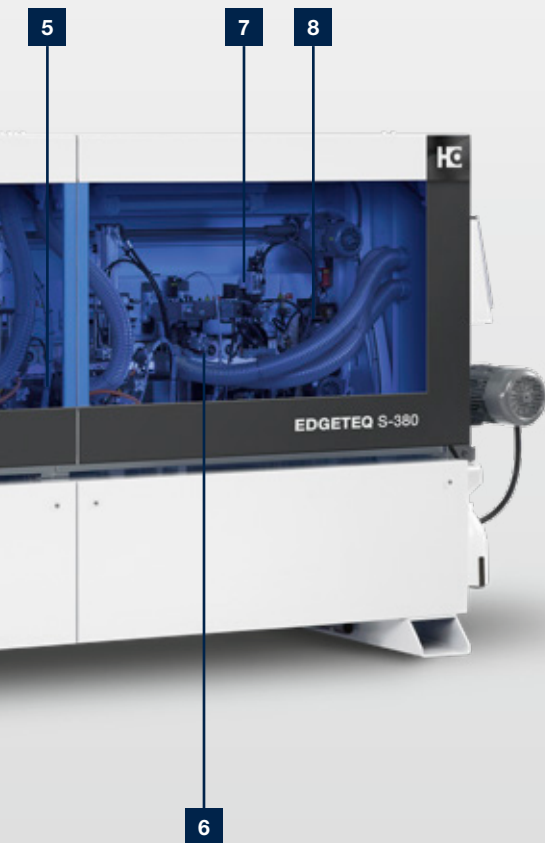

EDGETEQ S-380 Model 1650 HF

Feed speed: 8 – 18 m/min

- 1 Joint trimming unit
- 2 Gluing unit
- 3 Snipping unit with pneumatic adjustment chamfer/straight and pneumatic 2-point-adjustment
- 4 Rough trimming unit with pneumatic 2-point-adjustment
- 5 Multifunctional profile trimming unit
- 6 Profile scraper with quick-change heads and pneumatic adjustment
- 7 Glue joint scraper
- 8 Buffing unit

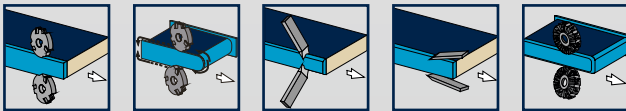

EDGETEQ S-380 – Model 1660 HF

This model comes with the same equipment as Model 1650 HF plus a fine trimming unit.



EDGETEQ S-380 – Models 1650 E – 1660 E: The high-performance compact class

Even in their basic equipment configuration, the edition models offer a high level of automation and simple processing of several radii as standard. The basic versions are equipped with a joint trimming unit, a precise Quickmelt gluing unit, a 2-motor snipping unit, a multi-stage trimming unit and a profile trimming unit. A multi-stage scraper, a glue

joint scraper and a buffing unit ensure a perfect finish. The edition models are characterized by their high level of automation. The multi-stage trimming unit and multi-stage scraper provide the optimum radius and consequently the very best results for frequently changing applications.

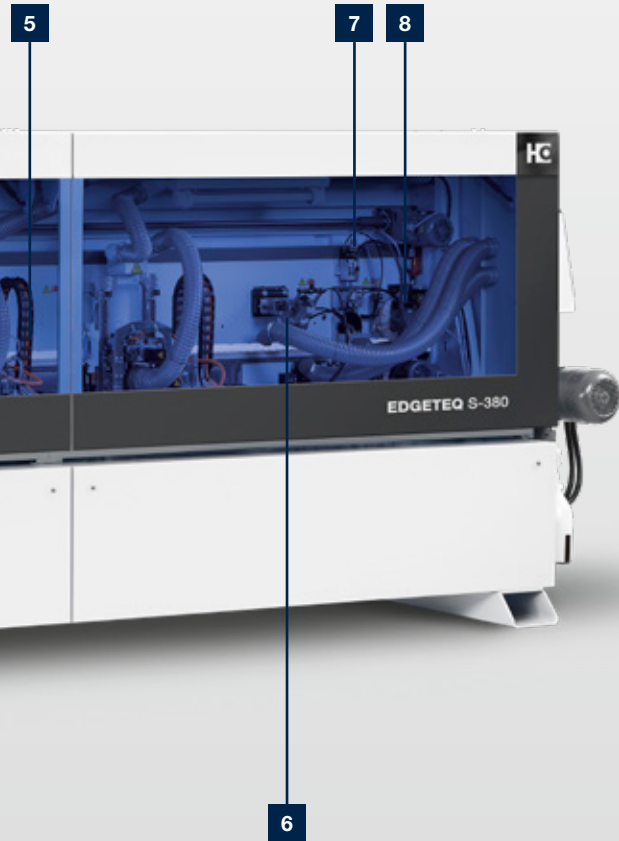

EDGETEQ S-380 Model 1650 E

Feed speed: 8 – 20 m/min

- 1 Joint trimming unit
- 2 Gluing unit
- 3 Snipping unit with pneumatic adjustment chamfer/straight and pneumatic 2-point-adjustment
- 4 Multi-stage trimming unit MS40 with pneumatic 2-point-adjustment
- 5 Profile trimming unit
- 6 Multi-stage scraper MZ40
- 7 Glue joint scraper
- 8 Buffing unit

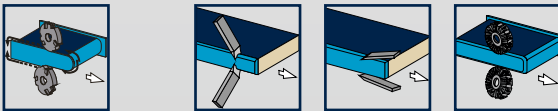

EDGETEQ S-380 – Model 1660 E

This model comes with the same equipment as Model 1650 E plus a 4-motor profile trimming unit.

EDGETEQ S-380 profiLine: Optimum results no matter what the edging material

The EDGETEQ S-380 profiLine series provides a diverse product range for precisely positioned edge banding in optimum HOMAG quality. The machines are available in different machine lengths which can be integrated into any

machine environment. By equipping the machine individually with a choice of different units, it can be used for wide-ranging different production assignments.





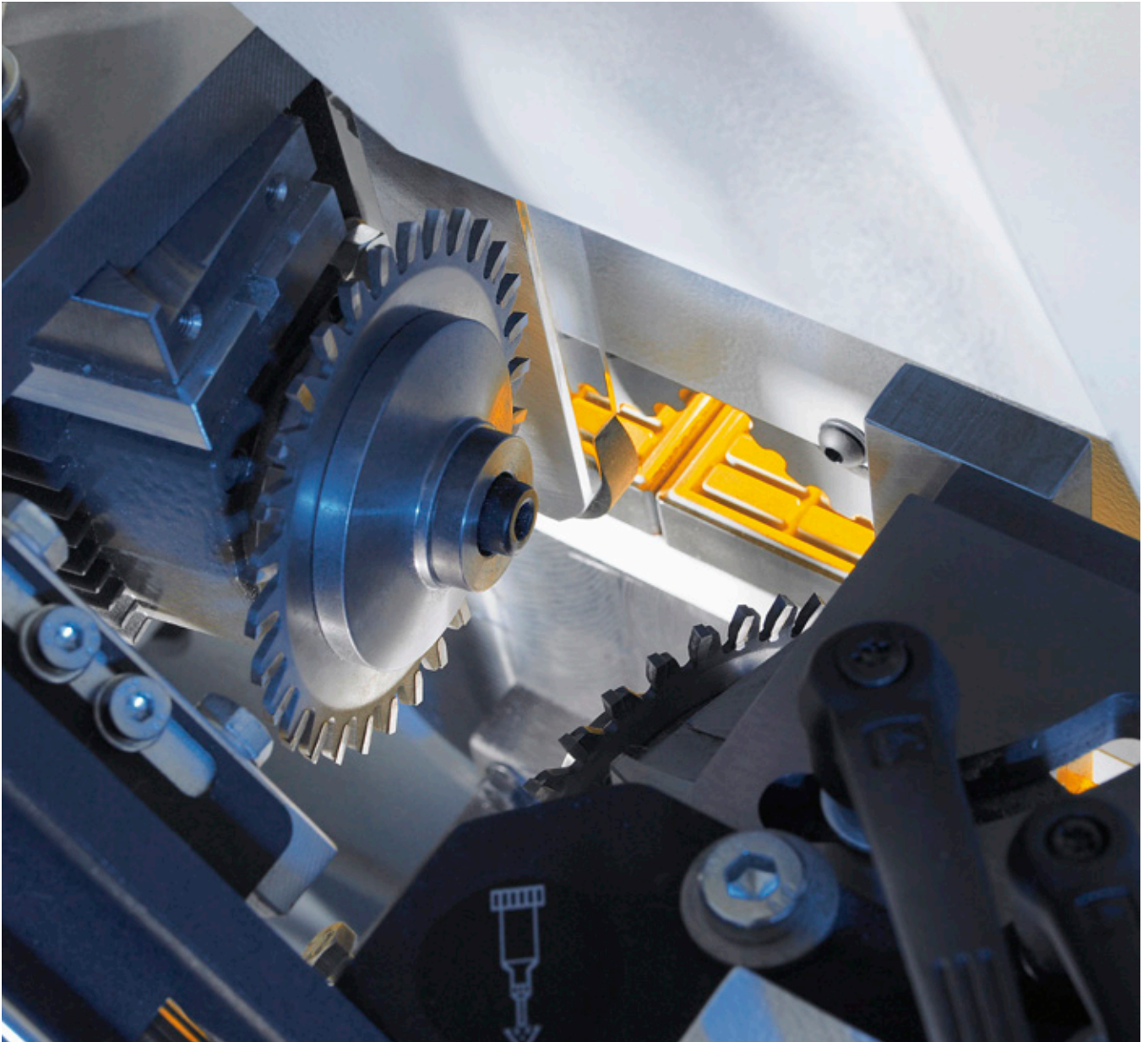

Our range of modular units: The right solution no matter what the requirement

For wide-ranging different processing tasks, we use units from our tried and tested modular range. By continuously extending the offered functions, we ensure that you have the right solution available to cope with changing trends.

Presenting a range of units for joint trimming, gluing, snipping, profile trimming, grooving and finish processing. Their extreme precision and state-of-the-art technology will boost the flexibility and efficiency of your production.

Workpiece feeding

Precise workpiece feeding is a pre-condition to achieve perfect edge quality. Our solutions are your benefit: infeed

fence, infeed stop, sliding carriage or workpiece support.

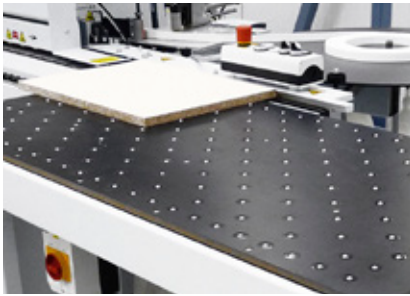

Air cushion table

For easy workpiece feeding.



Automatic infeed fence adjustment

Program-controlled precision adjustment with precise infeed fence adjustment by means of servo axis.



Infeed stop

For minimum workpiece spacing and safe operation.

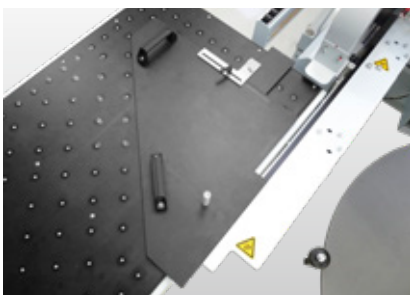

Feeding system for small parts

For easy feeding small workpieces into the machine.



Sliding carriage

Robust linear guiding system to secure rectangular workpiece feeding.

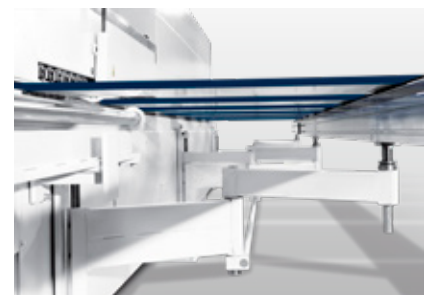

Scissor-design workpiece support

The workpiece support in scissor-design is conveniently extendable to 1,000 mm.

Spraying units

Spraying units help to improve edge quality throughout the complete processing. Separating agent avoids that hot melt glue residuals adhere to the workpiece and antistatic agent avoids that plastic chips adhere to the workpiece.

Cleaning agent helps to easily remove glue residuals. Lubricant is applied to protect sensitive surfaces before trimming and to prevent gloss marks on the workpieces.

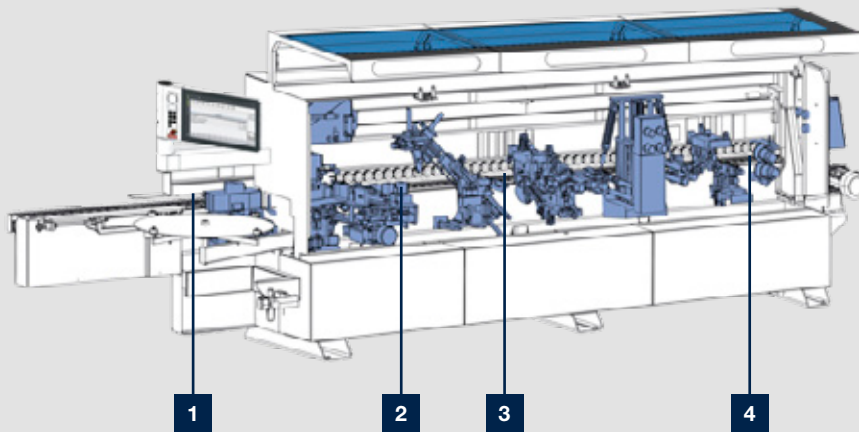

- 1** Separating agent
- 2** Lubricant
- 3** Antistatic agent
- 4** Cleaning agent

Joint trimming unit

The HOMAG joint trimming units provide the perfect basis for splinter-free workpiece edges and glue joints with a consistently high standard of product quality.

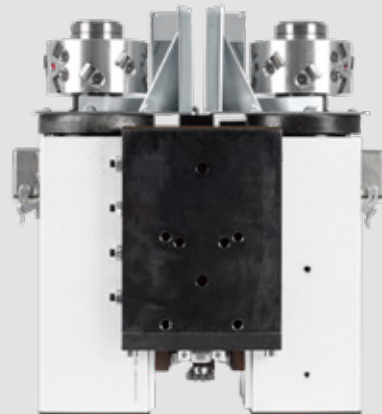

Joint trimming unit

Perfect cut and long service life due to diamond tipped tools for optimum edge joint quality. The diameter is 100 mm.



Systematic gluing

Achieving perfect gluing results depends on the optimum interaction of entirely different factors. The workpiece pre-heating, the application unit, quick clamping system, melting unit, magazine and pressure zone from HOMAG are all designed for optimum coordination.



Workpiece pre-heating with heaters

High-strength gluing due to an optimum workpiece pre-heating.



QA65N application unit

For both EVA and PUR.



Automatic edge infeed device

For fast changeover between different coiled materials.



Insertion of wide solid strips

Extra wide magazine with high capacity for solid strips and optimum access to reload.

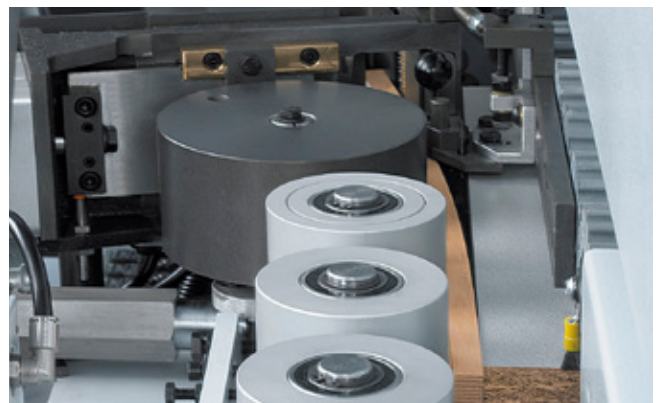

Pressure zone

Heavy pressure zone up to an edge thickness of 15 / 20 mm and a panel height of 60 mm for optimum glue joint quality.

Gluing unit – safe hot-melt glue application

HOMAG gluing units are ideal for a fast, positive-locking glue bond. The heated glue roller ensures an optimum gluing temperature. On request, the gluing unit can also be

individually equipped with a PUR pre-melting unit – allowing high availability and optimum gluing quality.

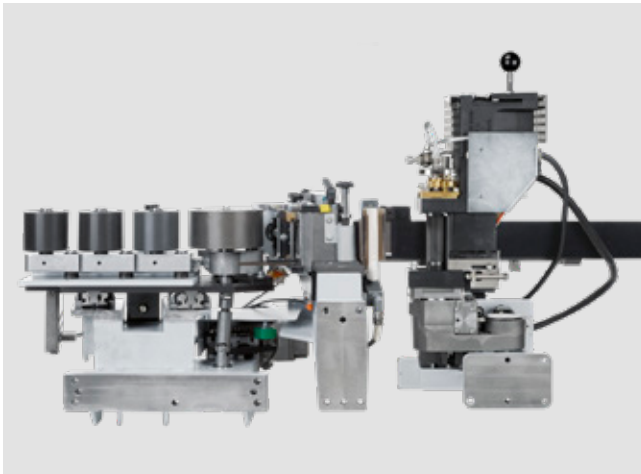

QA65N glue application system – gravity fed

The application unit can be easily removed by means of a quick-change device with pneumatic interface.

YOUR BENEFITS AT A GLANCE

- Short heating-up time by sensed level control (2 levels selectable)
- Easy removal of the application unit with quick-release lock
- Pre-melting unit for melting hot-melt glue as required either manually or automatically
- Glue roller with integrated heating guarantees constant temperature and viscosity for all workpiece thicknesses
- Electropneumatic glue roller and tank clamping prevents glue soiling on the trailing edge of the workpiece
- Tracing pad prevents wear of the application roller and ensures a consistent glue film thickness
- Glue roller lift-off on feed stop
- Automatic glue adjustment

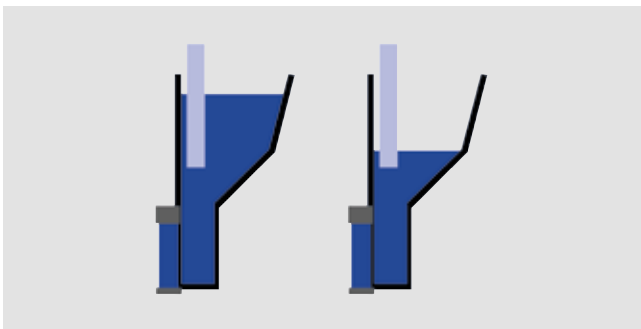

Sensor for checking the fill level of the application unit

Switching to a lower glue level guarantees a fast heat-up time for processing small batch sizes.

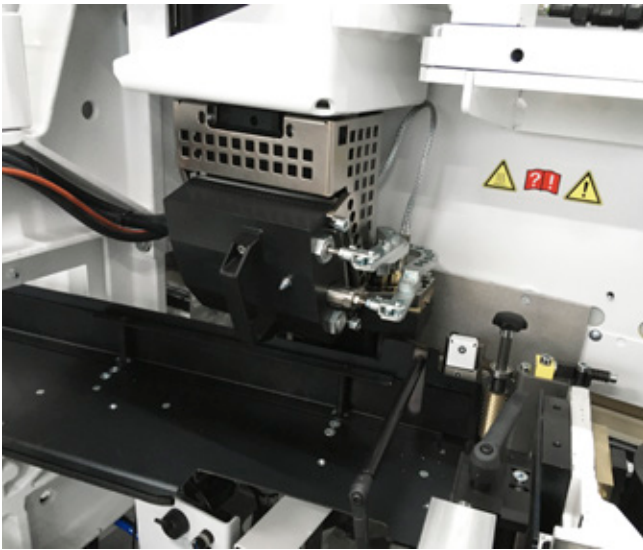

Automatic glue adjustment

The automatic glue adjustment is realized by easily and rapidly adapting the glue amounts via the powerTouch user interface. Exact and rapidly adjustable glue amounts lead to

- optimum gluing quality
- increased availability and performance
- higher cost efficiency



Pre-melting unit for EVA

High availability as only as much glue is melted as is actually needed. A perfect glue quality is ensured by the quickmelt system.



PUR glue and HOMAG – a strong alliance

The moisture and heat resistance of furniture is increased by the use of polyurethane (PUR) hot melt glue. Its use is ideal for furniture in damp areas such as bathrooms, kitchens and labs.



Your HOMAG PUR benefits at a glance

- One application unit for all glue types
- No additional application unit needed
- Quick, friction-locked thin film application by glue roll with integrated heater
- Can be used by the entry-level model to high-end machine as standard



PUR pre-melting unit

- Melting output 2.5 kg/h
- Temperature control to prevent overheating



PUR pre-melting unit

- Melting output 6 kg/h
- Temperature control to prevent overheating



Vacuum tank

- Compact, mobile tank for storing the PUR application unit
- No vacuum pump and no nitrogen required



Service station

- Pre-heating and cleaning station for the QA65N application unit with a storage area
- High flexibility through the use of 2 vacuum containers, each for one QA65N application unit or a PUR pre-melting unit 2.5 kg/h
- No vacuum pump and no nitrogen required

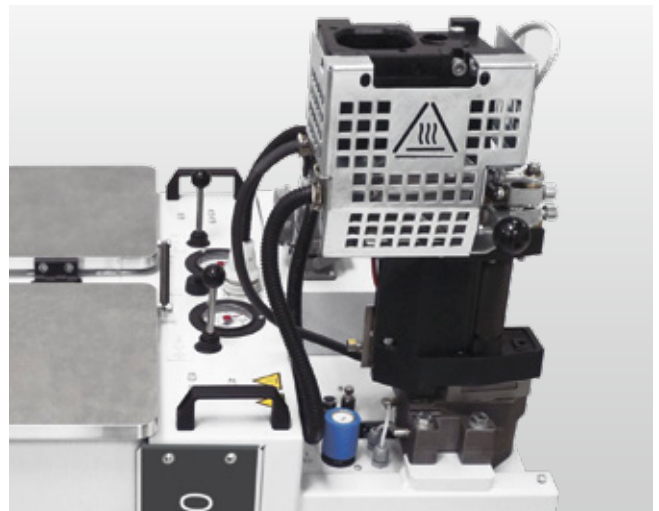

Service station

- Picture shows application unit in holding device for pre-heating

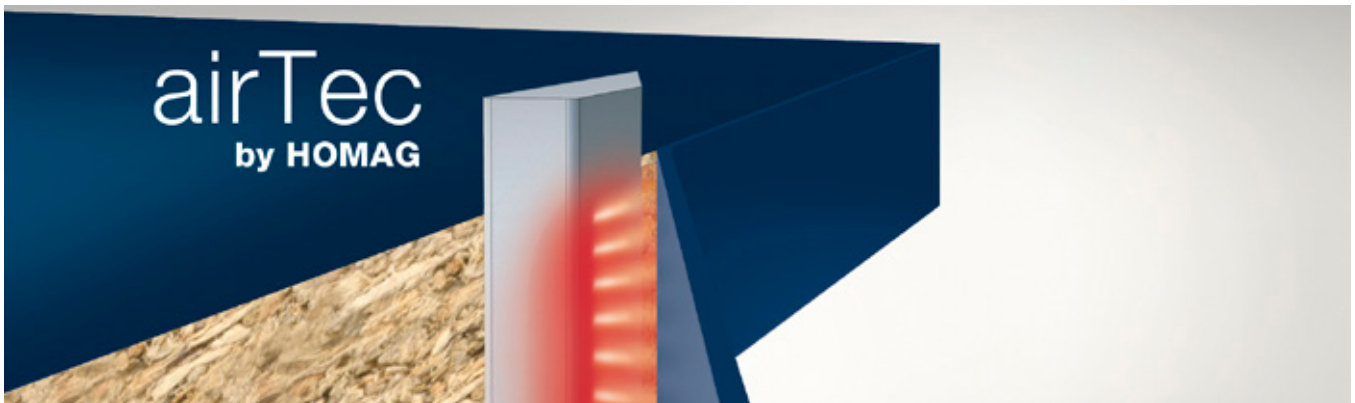

airTec – the ideal entry into zero joint technology

The airTec process has become an established zero joint solution in woodworking shops and SMEs. The nerve center of the HOMAG airTec unit is a rotation air heater which not only operates with high efficiency and resource-saving but

also with significantly lower noise emissions. airTec can be used to process all types of currently popular, laser-suitable edging types. This means great flexibility for all materials and colors.



Edge banding with “no joints”

The airTec method bonds the edging to the panel using hot air. This requires the use of special edges. These comprise a decor layer and a function layer. The HOMAG airTec unit melts the function layer at an even temperature and flow rate and bonds it perfectly to the narrow surface.



Easy integration

The airTec reactivation unit is installed in such a way that it is possible to work with either the standard application unit or the airTec system. The antistatic spraying unit for an optimum processing result comes as standard with all airTec units.

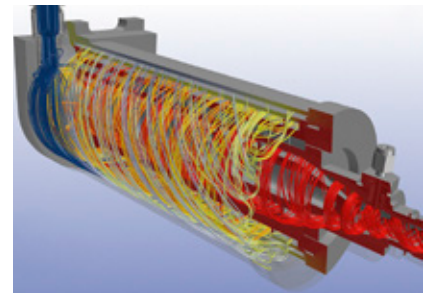

Innovative rotation air heater

The source of energy heats the air while at the same time acting as a heat store for subsequent repeated air heating. It also works with reduced air consumption and reduces heating of the surrounding atmosphere. Almost the only noise generated is emitted during the activation process, and is below the noise level of the other processing units.

Snipping units for cutting the face side overhang

The snipping unit prepares the workpieces perfectly for subsequent trimming operation. The face side can be snipped either straight or with chamfer.

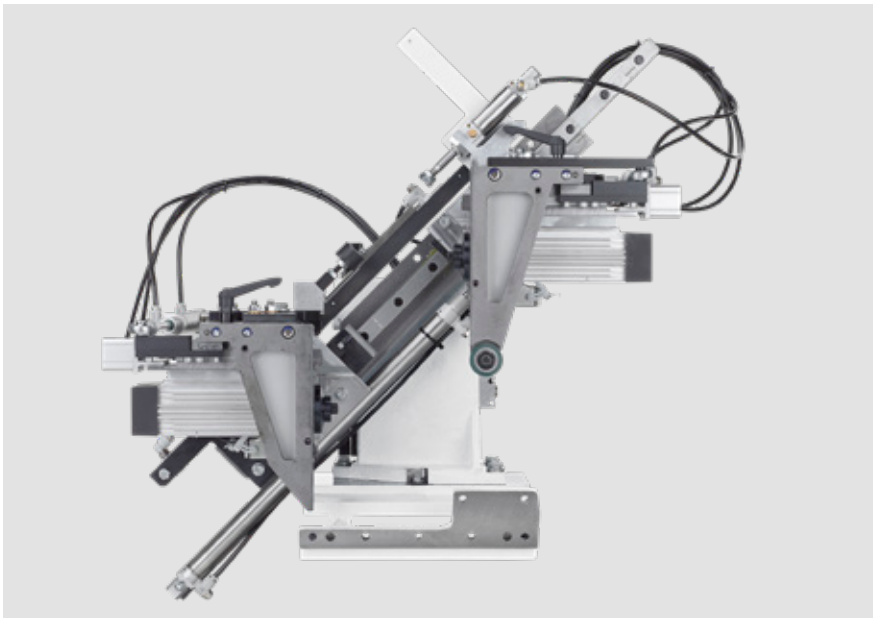

Snipping unit

Exact snipping cut using a robust snipping unit with a highly precise linear guide and workpiece gap optimization (optional) to achieve higher output in the same processing time. Soft-touch function for optimum snipping results even at high feed speeds.

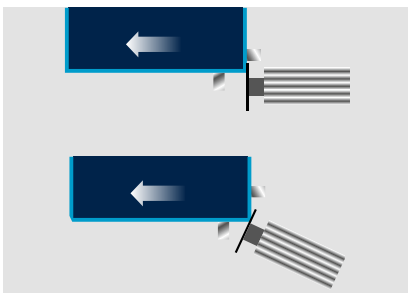
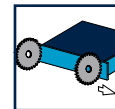

Automation as standard

Programmable chamfer/straight snipping motor adjustment for fast changeover between straight snipping and snipping with chamfer.

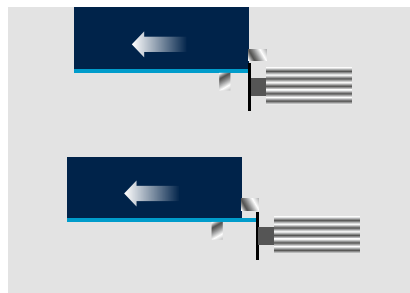

Automation to suit every need

For fast changeover between flush snipping (e.g. of solid strips or inlay shelves) and snipping with overhang (e.g. for finish trimming with profile trimming unit).

Trimming units for flush trimming

With the rough trimming unit and the fine trimming unit HOMAG offers the right solution for the processing

of projecting edges. The trimming units are equipped exclusively with tools which capture the chips controlled.

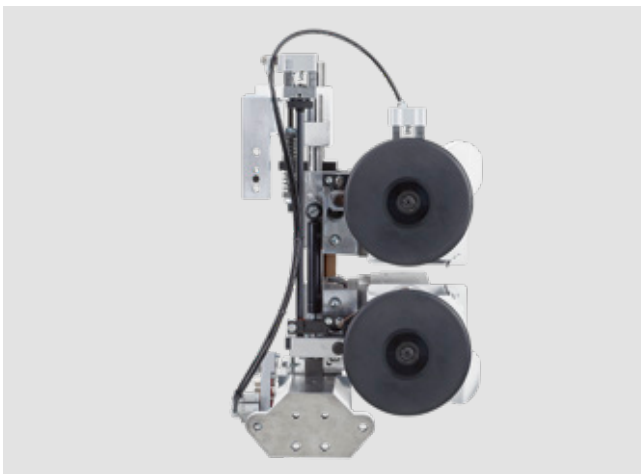

Rough trimming unit

For rough trimming of all common edge banding materials.

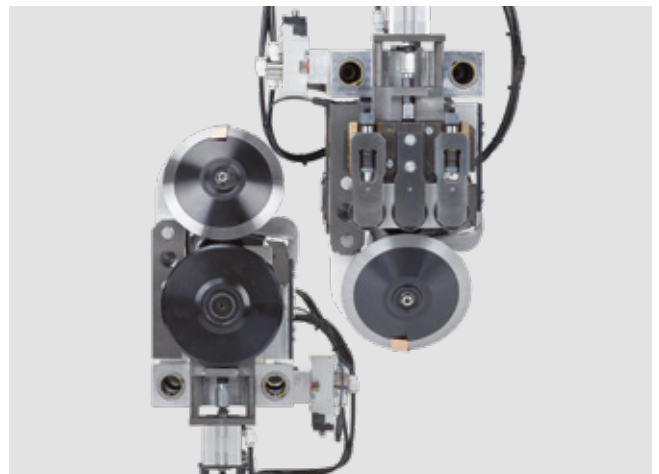

Fine trimming unit

For trimming chamfers and radii with optimized chip extraction and manual adjustment.

Automation to suit every need

Stepless chamfer/radius adjustment for rapid changes between processing operations, e.g. from 0.3 mm to 2 mm edge.

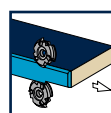
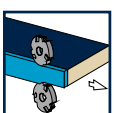

Trimming with multi-stage technology

The range of edges and panel materials is continually growing and so is the demand for flexibility. It is immaterial if edges are made from plastic, solid wood or veneer, or

if workpieces have high-gloss surfaces. The multi-stage trimming unit always offers the optimum radius for frequently changing applications, and therefore the best results.



Multi-stage trimming unit MS40/45

Fully automatic changeover to three different profiles using servo motors*.

Image shows nesting package.

* Servo drives consist of motors with a stepless adjustment. They impress thanks to a high positioning accuracy and are particularly suitable for small positioning distances.

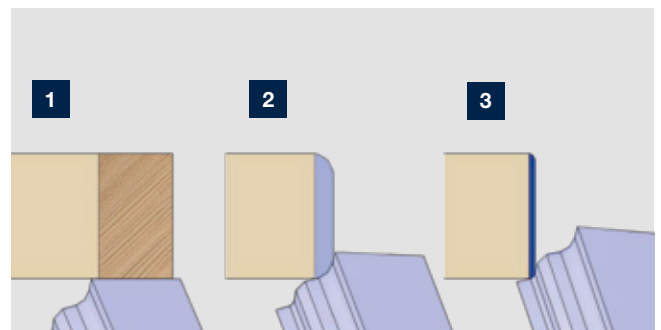

1 Without profile (MS40/45)

2 Profil 1

3 Profile 2



Profile trimming units

The profile trimming units are universal. The user has the choice to adjust the units manually or to control them via program. High precision adjustment up to speeds of

20 m/min. Our profile trimming units permit both corner rounding and trimming of upper and lower projecting edges.

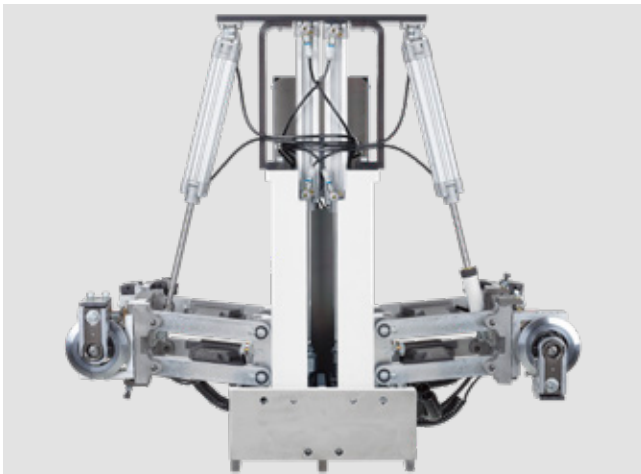

Profile trimming unit FF20

For rounding corners on thick PVC edges, as well as top edges on postforming and softforming parts. Equipped with an automatic adjustment to switch between thin and thick edges. Workpiece thickness 60 mm.

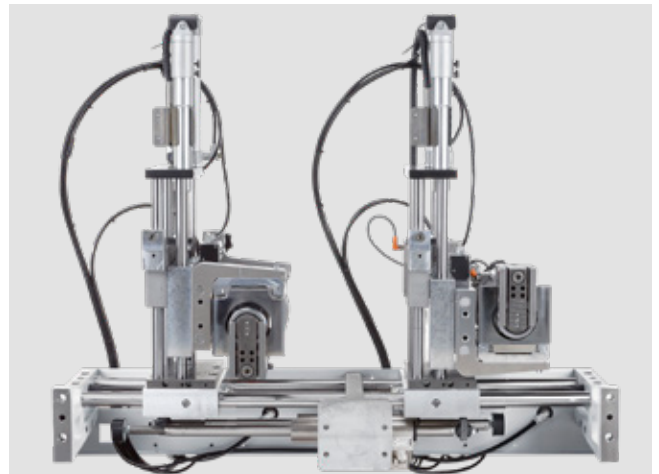

Multifunctional trimming unit MF50

Trimming of the top and bottom edge overhang as well as corner copying on the front and rear edges. Equipped with an automatic adjustment to switch between thin and thick edges. Workpiece thickness 60 mm.

Automation to suit every need

Adjustment between two different radii and automatic adjustment of the tracing rollers.

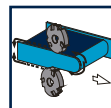
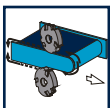



Multifunctional trimming unit MF60 Servotrim

Trimming of the top and bottom edge overhang as well as corner rounding on the front and rear edges. Servo-controlled movement with soft-touch function for optimum handling of e.g. high gloss surfaces or lightweight panels. Workpiece thickness 60 mm.

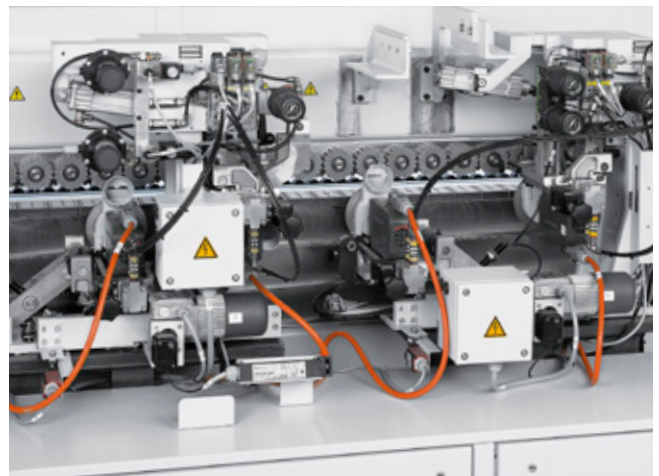

Profile trimming unit FF12

For corner rounding of thick PVC-edges as well as head edges on postforming and softforming parts up to a feed speed of 20 m/min. Equipped with an automatic adjustment for all edge thicknesses. Workpiece thickness up to 60 mm.

Automation to suit every need

Adjustment between two different radii and automatic adjustment of the tracing rollers.

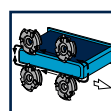
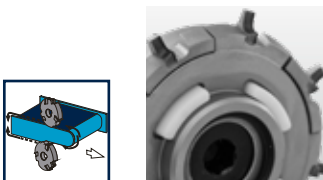



Grooving unit

A swiveling grooving unit is available for grooving. If required, the workpiece underside and the front side can be grooved.



Tiltable grooving unit

For grooving the underside and the front sides of workpieces. For producing continuous, non-continuous or jump grooves.



Safety device

for grooving solid strips in synchronous rotation. For model 1670 FGC.

Finishing units

The quality of your products is increased by the use of perfectly coordinated finishing units. With ideally coordinated

finishing units, HOMAG adds a perfect, high-quality final touch to your products.



Multi-stage scraper unit MZ40
Fully automatic adjustment between 2 different profiles by means of servo motors with a stepless adjustment.

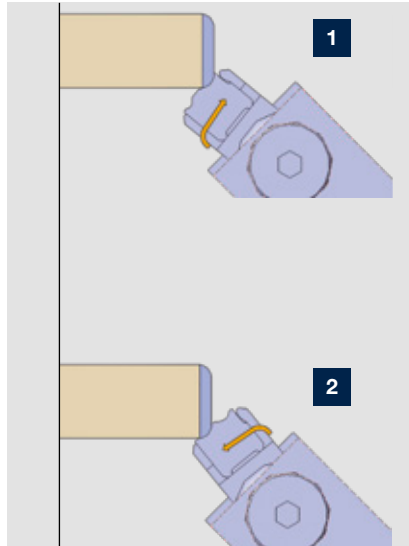

1 Profile 1
2 Profile 2

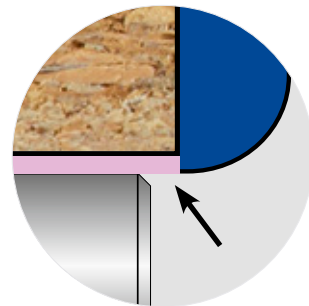

Optimum compensation for protective films

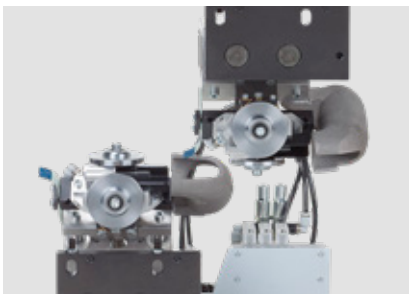

Profile scraper
Unit to smooth radii or chamfers, equipped with quick change heads for fast profile change.

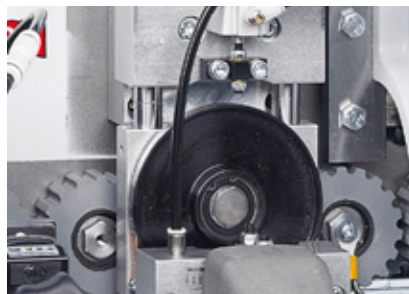

Glue joint scraper
For the perfect finish.



Buffing unit
To polish edges and maintain their natural color.

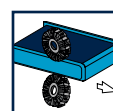
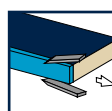
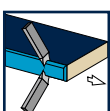

Special processes

To individually expand the functional scope of the machines, we offer you solutions for processing workpieces with protection foil/high gloss and e.g. acute- or obtuse-angled

parts or parts with hinge holes as they are produced with nesting.

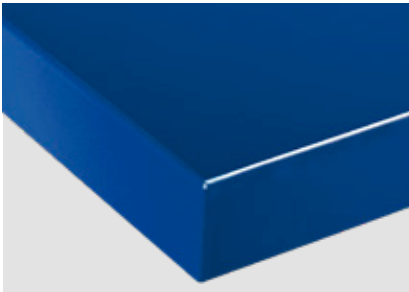

Workpieces with protection foil / high gloss

Perfect high gloss parts are achieved thanks to a spraying unit for the application of lubricant and a motor-driven top pressure belt.



Lubricant spraying unit



Top pressure driven by motor

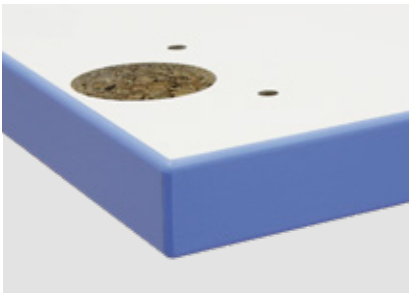

Workpieces with hinge holes (nesting process) or acute-/obtuse-angled parts

Different tracing elements are mounted depending on the unit configuration. They are ideal for processing parts with hinge holes, as they are produced with nesting, and acute- or obtuse-angled parts.

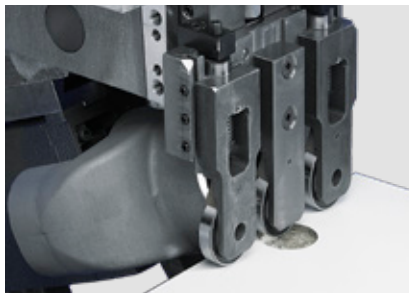

Tracing elements for processing parts with hinge holes



Small parts processing

Increased flexibility in the production range thanks to optimum workpiece guidance and processing workpieces also with lengths < 240 mm down to a minimum length of 120 mm. This is reached through a short roller distance at the top pressure beam.

LOOPTEQ return conveyors: Increased productivity for your edge banding machine

Workpiece return conveyors of the LOOPTEQ series provide the ideal complement to the machines of the EDGETEQ S-380 series. In one-man operation, the panel return flow is

optimized and allows a lean and efficient production process. Depending on the individual requirements the machines can be combined with a LOOPTEQ O-200 or a LOOPTEQ O-300.

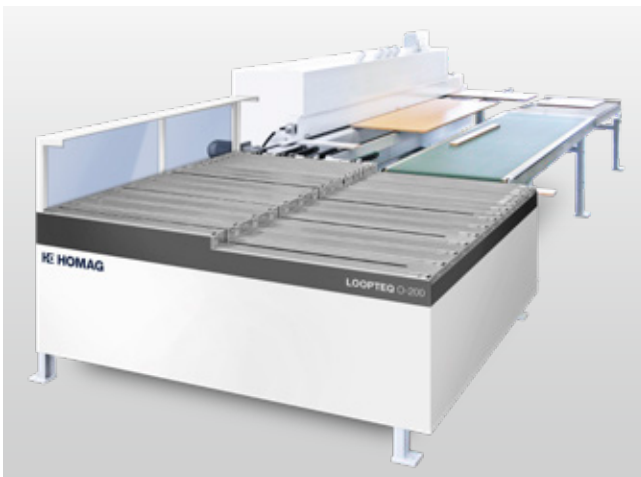

LOOPTEQ O-200 – ideally suited for small, narrow, and medium-sized workpieces

- Fast amortization – pays off from 9 hours working time per week
- Flexible operator organization – thanks to economical one-man operation
- Ergonomic working – manual parts handling is reduced to a minimum
- Improved quality control – rapid response to material adjustments



LOOPTEQ O-300 – best suited for high material variety, from small and light up to large and heavy workpieces

- Fast amortization – pays off from 15 hours working time per week
- Low quality costs – gentle workpiece handling with air cushion table
- Flexible operator organization – thanks to economical one-man operation
- Ergonomic operation – releases operators from heavy physical work





The EDGETEQ S-380 profiLine offers more features than others

Compared to the pre-configured EDGETEQ S-380 models, the EDGETEQ S-380 profiLine series can be freely equipped

and offers additional processing units and even greater flexibility.



Several edgebanding processes on one machine

The EDGETEQ S-380 profiLine offers the possibility of selecting between several processes on one machine. The figure illustrates e.g. two pre-melting units for alternatively processing PUR and EVA. At the same time, the airTec zero joint technology can be used on this machine. This guarantees a maximum of flexibility.



Processing edges up to a thickness of 20 mm

More flexibility in the choice of edges thanks to the possibility of processing solid wood strips up to a thickness of 20 mm.

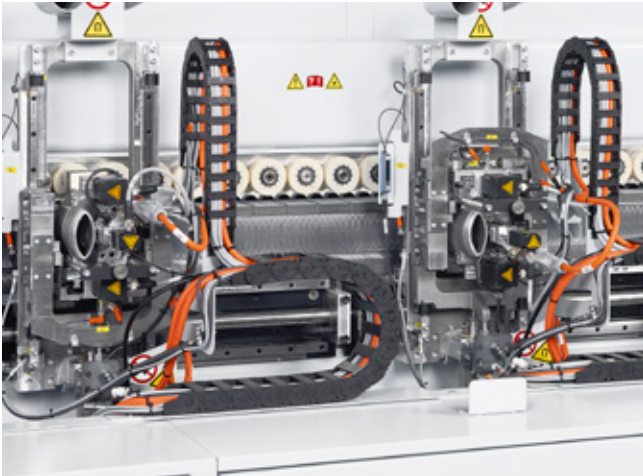

Multiple use of same processing units on one machine

For special processes it is useful to mount one unit in multiple ways to a machine. This is ensured by the EDGETEQ S-380 profiLine. The MF60 multifunctional profile trimming unit e.g. can be used in multiple ways on this series – to achieve a variety of different radii.



Belt sanding unit

For sanding straight veneer and solid wood edges including oscillation as a standard feature.



Standard trimming unit for grooving and profiling

Universal unit with high capacity for grooving and profiling work. Flexible use thanks to unlimited adjustment possibilities.



Safety device

for grooving solid strips in synchronous rotation.

Our successful powerTouch philosophy – standardized, simple, ergonomic, evolutionary

HOMAG machines are designed so that simple operation and reliable control are a matter of course. Our innovative touchscreen operating philosophy combines design and function in one control system.

The full HD multitouch monitor, ergonomic touch operation, simple navigation and the standardized user interface all enhance processing efficiency.



Standardized operating elements and software modules ensure that all HOMAG edge banding machines from EDGETEQ S-240 Model 1240 FC can be operated in the same way. They differ only in a few machines-specific details.

This not only simplifies operating different machines, but also makes for greater efficiency by significantly reducing the time spent on training and service.

Control with powerTouch

Using the widescreen format multitouch monitor, you control machine functions by direct touch contact. The

ergonomically optimized design and an array of help and assistant functions substantially simplify operation.



Standardized

Standardized operating elements, software modules and standardized design characterize the powerTouch control system for HOMAG machines. This allows different HOMAG machines to be controlled in the same way.



Ergonomic

Intuitive, direct control via the touch-sensitive touchscreen monitor.



Evolutionary

Design and function united in one control system. The futuristic powerTouch machine control system is combined with state-of-the-art operating concepts used in smartphones and tablet PCs.



Teleservice reduces on-site service visits

- Reduction in service costs
- Avoids unplanned machine downtimes
- Targeted planning for service visits and spare parts delivery
- Support for maintenance and operating personnel

YOUR BENEFITS

- 24" monitor with full HD resolution
- Fast overview of machine status
- Easy, user-oriented navigation
- Guided path to production readiness through traffic light indicator
- Ergonomic design of the operating panel
- Intuitive, natural touch operation on the machine
- Use of gestures, e.g. scrolling, swiping

TECHNICAL DATA EDGETEQ S-380 – MODELS 1600

	1650 FC	1660 FGC	1670 FGC	1650 HF	1660 HF
Overall length (mm)	5,773	6,273	6,773	5,773	6,273
Feed speed adjustable (m/min)	8 – 20	8 – 20	8 – 20	8 – 20	8 – 20
WORKING DIMENSIONS					
Workpiece width (mm)*					
with workpiece thickness 8 – 22 mm	70	70	70	70	70
Workpiece thickness (mm)	8 – 60	8 – 60	8 – 60	8 – 60	8 – 60
Edge thickness, coils (mm)	0.3 – 3	0.3 – 3	0.3 – 3	0.3 – 3	0.3 – 3
Edge thickness, strips / solid strips (mm)	0.4 – 12	0.4 – 12	0.4 – 12	0.4 – 15 **	0.4 – 15

* depends on the workpiece thickness

** depends on the equipment

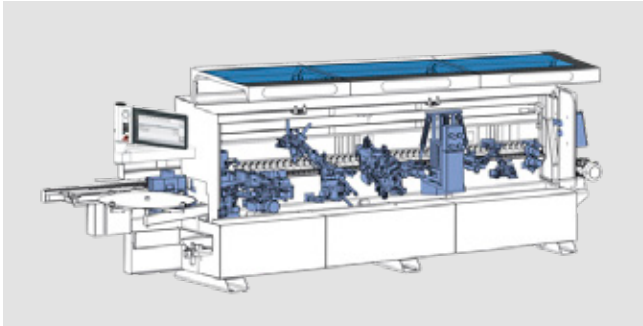

EDGETEQ S-380 – Model 1650 FC

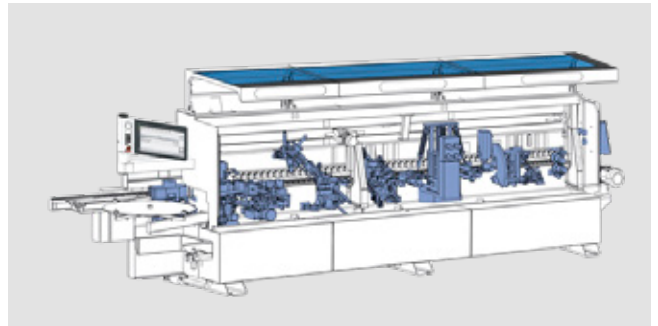

EDGETEQ S-380 – Model 1660 FGC

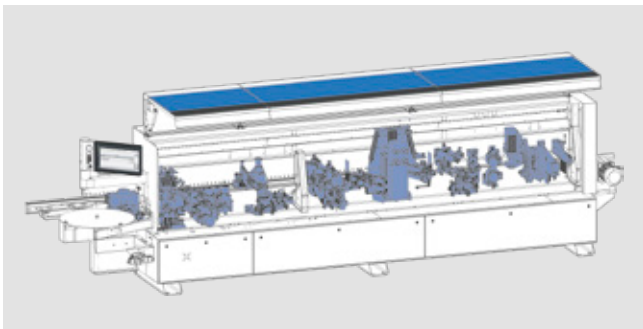

EDGETEQ S-380 – Model 1670 FGC

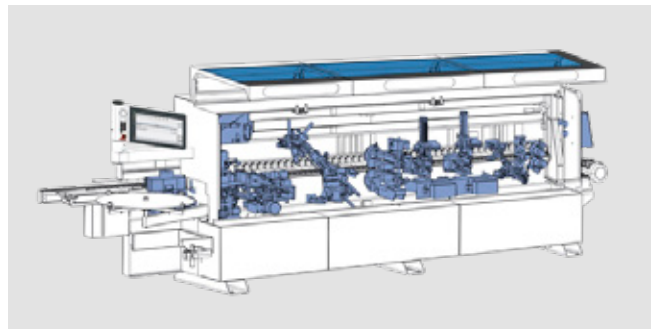

EDGETEQ S-380 – Model 1650 HF

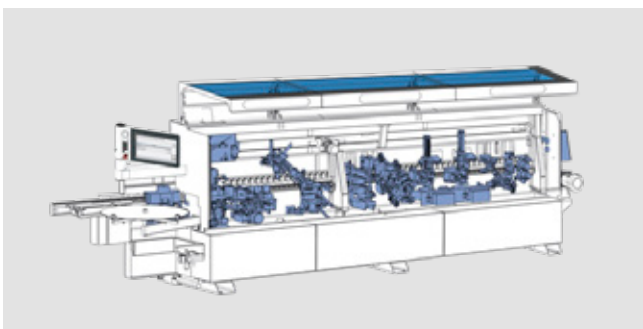

EDGETEQ S-380 – Model 1660 HF

TECHNICAL DATA EDGETEQ S-380 – MODEL 1650 E, 1660 E AND EDGETEQ S-380 PROFILINE

	1650 E	1660 E	PROFILINE
Overall length (mm)	5,773	6,573	4,773 – 8,273
Feed speed adjustable (m/min)	8 – 20	8 – 20	8 – 20
WORKING DIMENSIONS			
Workpiece width (mm)*			
with workpiece thickness 8 – 22 mm	70	70	70
Workpiece thickness (mm)	8 – 60	8 – 60	8 – 60
Edge thickness, coils (mm)	0.3 – 3	0.3 – 3	0.3 – 3
Edge thickness, strips / solid strips (mm)	0.4 – 12	0.4 – 12	0.4 – 20

* depends on the workpiece thickness

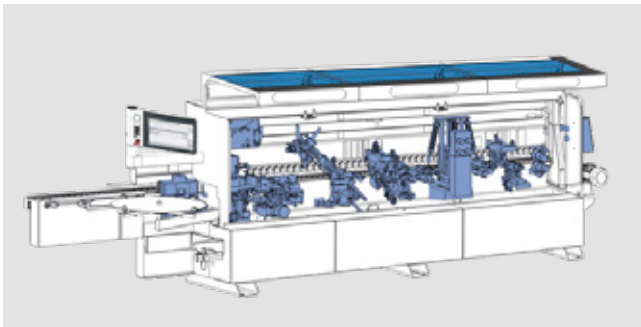

EDGETEQ S-380 – Model 1650 E

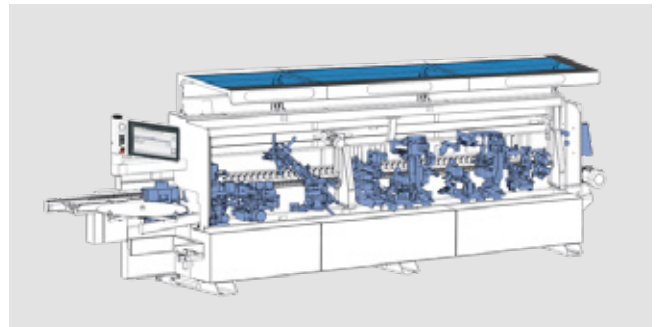

EDGETEQ S-380 – Model 1660 E

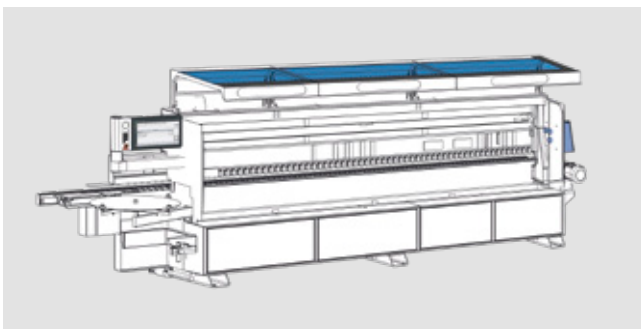

EDGETEQ S-380 profiLine

HC LIFE CYCLE SERVICES

Optimal service and individual consultations are included in the purchase of our machines. We support you with service innovations and products which are especially tailored to your requirements. With short response times and fast

customer solutions we guarantee consistently high availability and economical production – over the entire life cycle of your machine.



REMOTE SERVICE

- Hotline support via remote diagnosis by our trained experts regarding control, mechanics and process technology. Thus, more than 92% less on-site service required and consequently a faster solution for you!
- The ServiceBoard App helps to solve tasks in a fast, simple and concrete way. This is achieved by mobile live video diagnosis, automatic sending of service requests or the online spare parts catalog eParts.



SPARE PARTS SERVICE

- High spare parts availability and fast delivery.
- Ensuring quality by predefined spare parts and wear parts kits, comprising original spare parts.
- Identify and inquire for spare parts online under www.eParts.de 24/7, or buy even faster and more comfortably in the new HOMAG eShop (shop.homag.com).



MODERNIZATION

- Keep your machinery up to date and increase your productivity as well as your product quality. This is how you can meet tomorrow's requirements today!
- We support you with upgrades, modernization as well as individual consultancy and developments.



DIGITAL SERVICES

- serviceRemote – the new remote service solution of the future! Fast restart of production because the remote service employee has extensive access to relevant physical data.
- serviceAssist – provides help for self-help. The preventive solutions proposed in the new App are the combination of our experiences and existing machine data.



SOFTWARE

- Telephone support and consultancy through software support.
- Digitalization of your spare parts via 3D scanning saves time and money compared to new programming.
- Subsequent networking of your machinery with intelligent software solutions ranging from construction to production.



FIELD SERVICE

- Increased machine availability and product quality by certified service staff.
- Regular checks through maintenance / inspection guarantee the highest quality of your products.
- We offer you the highest availability of technicians in order to reduce downtimes in case of unpredictable troubles.

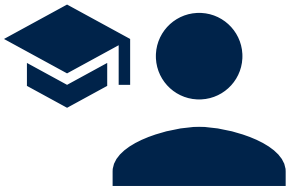

TRAINING

- Thanks to training perfectly suited to your requirements, your machine operators can optimally operate and maintain the HOMAG machines.
- The training also includes customer-specific training documents with exercises proven in practice.
- Online training and webinars. Learn without traveling, meet your trainer in the digital classroom.

For you more than...

1,350

service employees worldwide

92%

less on-site service thanks to successful remote diagnosis

5,000

customers in trainings / year

150,000

machines, all electronically documented in 28 different languages – in eParts

HOMAG Group AG

info@homag.com

www.homag.com



YOUR SOLUTION