

Double-end tenoner FPL 520



Optimat | **profi line** | **power line**

HOMAG double-end tenoner: Maximized capability, minimized wear and maintenance

Angular cuts, sizing, profiling, rebating and grooving. The HOMAG double end tenoner has a wide range of capabilities to offer. Durable and reliable, this is a machine which guarantees top quality results plus high output. Ideal for producing doors, windows, fronts and panels.



All done in just two rounds

Two passes - one transverse, one longitudinal - and this double champion has processed all four sides of the workpiece. Switched in sequence the productivity is increasing enormous. At the same time, the machine remains flexible and offers capacity for automation in line with requirements.

Through the machine with outstanding reliability and angular precision

Meticulously engineered dogs transport the workpieces with absolute angular precision during the transverse processing pass. The dogs can be adjusted - infinitely variable adjustment optional - and are simply recessed into the chain links and carried along during longitudinal processing. They transport even profiled or softforming components through the machine with the utmost reliability and provide optimum protection against damage.



Longitudinal and transverse precision

FPL 525: Machine with a short inlet area and infeed for pure longitudinal processing only.

FPL 526: Machine with extended chain track for use as a solo machine for longitudinal and transverse processing or as a second machine in a line for transverse processing.

The modular units – flexibility and compatibility at all times

Is it possible to be a master of all trades? – Yes it is – with our modular system of processing units! A wide range of units is at your service to fulfil wide-ranging different processing operations. The modular range is continuously updated to comply with every conceivable requirement of your production.

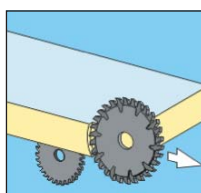
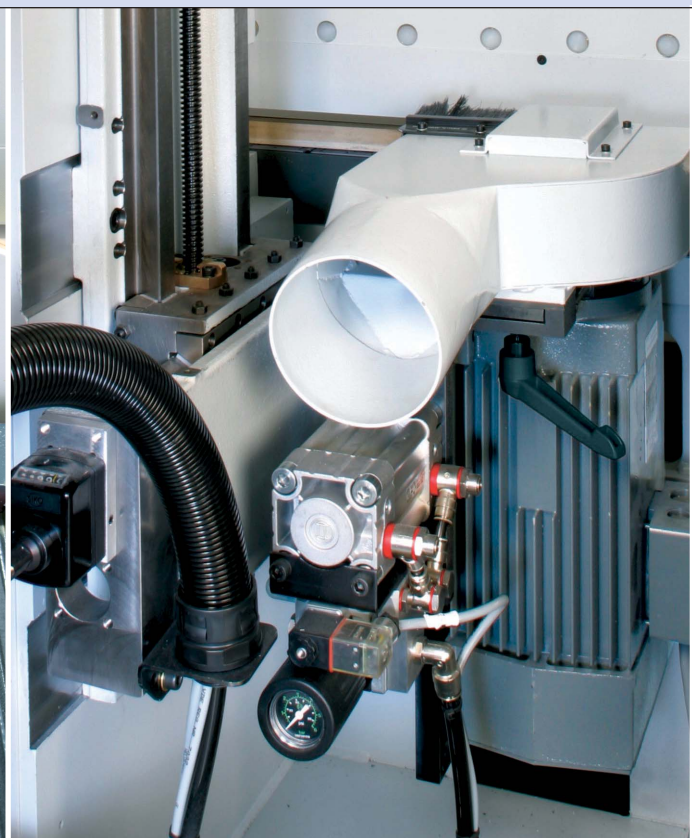

Scoring/hogging

Perfect sizing without splintering, even with coated or veneered panels. Pre-scoring unit with lift-off device. Hogging unit with cross support and extraction hoods

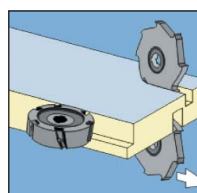

Trimming

Using standard trimming unit SF20, grooves and rebates are precisely trimmed inside the machine without the need for any additional processing operation.

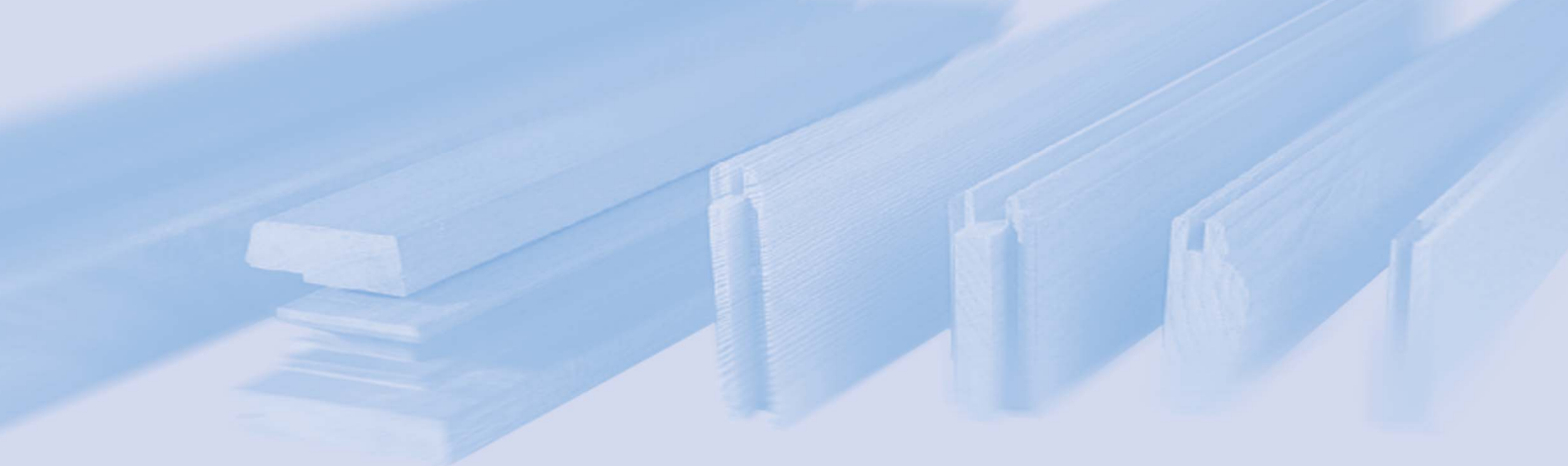

Option:

Automatic horizontal/vertical adjustment of the standard trimming SF20 using the control terminal.

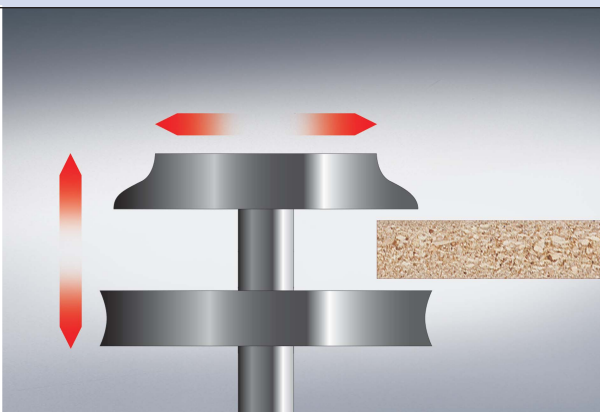

Option:

Swivel device for manual swivel action of the standard trimming unit SF20 by means of spindle drive.

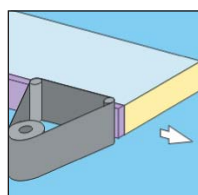

Profile sanding unit PS 10

For sanding profiles and straight edges. Long belt length (2,500 mm), two belt speeds, belt cleaning by means of air jet. Swivel range 30° upwards and 45° downwards

Option: belt oscillation

It pays to be a HOMAG customer

HOMAG is everywhere. A well-developed servicing, sales and dealer network means even shorter distances, rapid response and improved customer proximity - around the world.

Practically-oriented training

Although HOMAG products are designed for outstanding operating simplicity, thorough training does help cut down on commissioning times, reduces trial wastage, helps develop the skills of the operator and generally improves efficiency

With this aim in mind, customer training courses are held in a number of languages in our own training centre.



Careful maintenance

Scheduled, correctly performed maintenance helps reduce costs and increase machine productivity.

Identical parts, simple handling

A large number of the parts, control elements and assemblies used in HOMAG Group plants and machines are identical. The wide-ranging benefits of this policy include simplified operation, lower costs, streamlining of spare parts management and also faster maintenance and servicing - to name only a few.

Remote diagnosis worldwide

All NC machines are fitted in the factory with a modem to allow remote diagnosis anywhere around the globe. A search for possible faults is performed from the HOMAG Service Centre. Once localized, all errors can be remedied immediately over the telephone line.

Specifications

Optimat FPL 525 (Line version machine I)

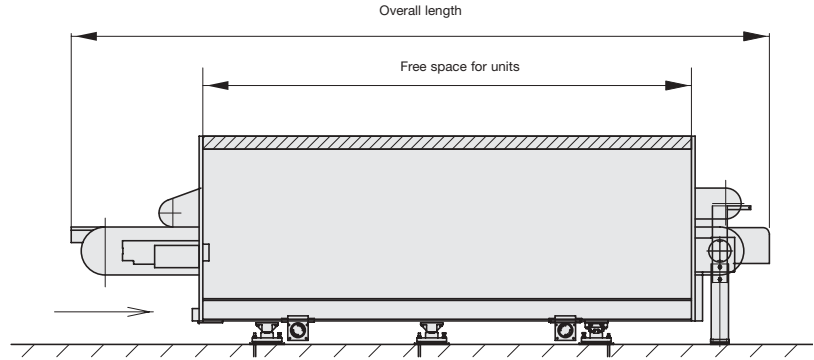

Optimat FPL 526 (Single machine / Line version machine II)

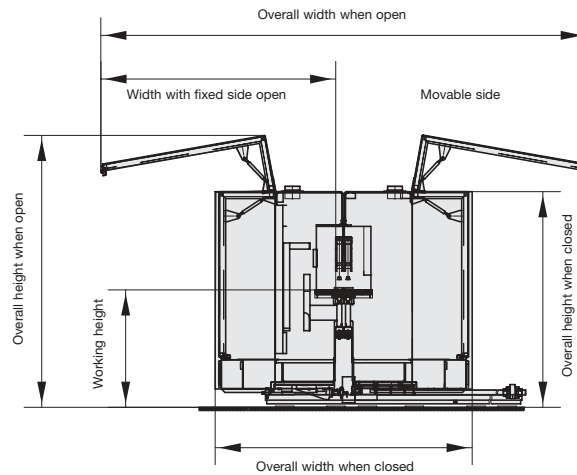
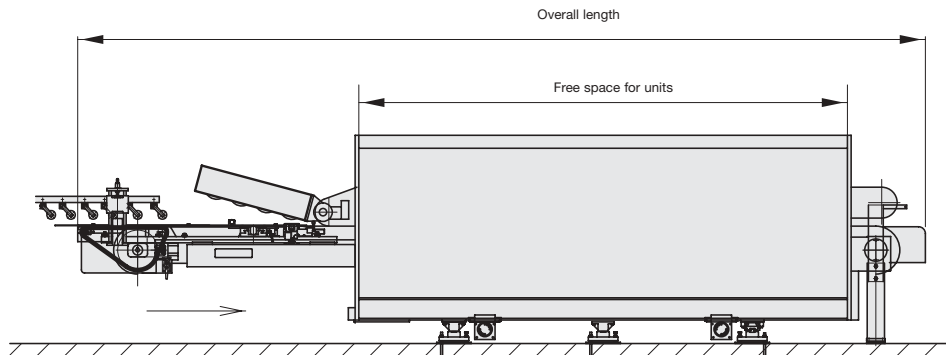

	Length 4	Length 6	Length 8
Machine dimensions			
Overall length FPL 525 [mm]	3,650 (143,700")	4,650 (183,070")	5,650 (222,440")
Overall length FPL 526 [mm]	4,650 (183,070")	5,650 (222,440")	6,650 (261,810")
Free space for unit [mm]	1,840 (72,441")	2,800 (110,236")	3,760 (148,031")
Air velocity [m/s]			
		28 (91,8631 ft. p. sec)	
Pressure loss [mm/Ws]			
		250 (9,842 in. / w.g.)	
Overall height when open [mm]			
		2,200	
Overall height when closed [mm]			
		1,740	
Working height [mm]			
		950	
Overall width when open [mm]			
		3,800 + Working width	
Overall width when closed [mm]			
		1,950 + Working width	
Width with fixed side enclosure open [mm]			
		1,900	

Specification and photo details without commitment.
We reserve the express right to make changes in the interests of progress.



A member of the HOMAG Group



HOMAG Holzbearbeitungssysteme AG

Homagstraße 3-5

72296 SCHOPFLOCH

GERMANY

Tel. +49 7443 13-0

Fax +49 7443 13 23 00

info@homag.de

www.homag.com

