

Processing centre

Venture 313

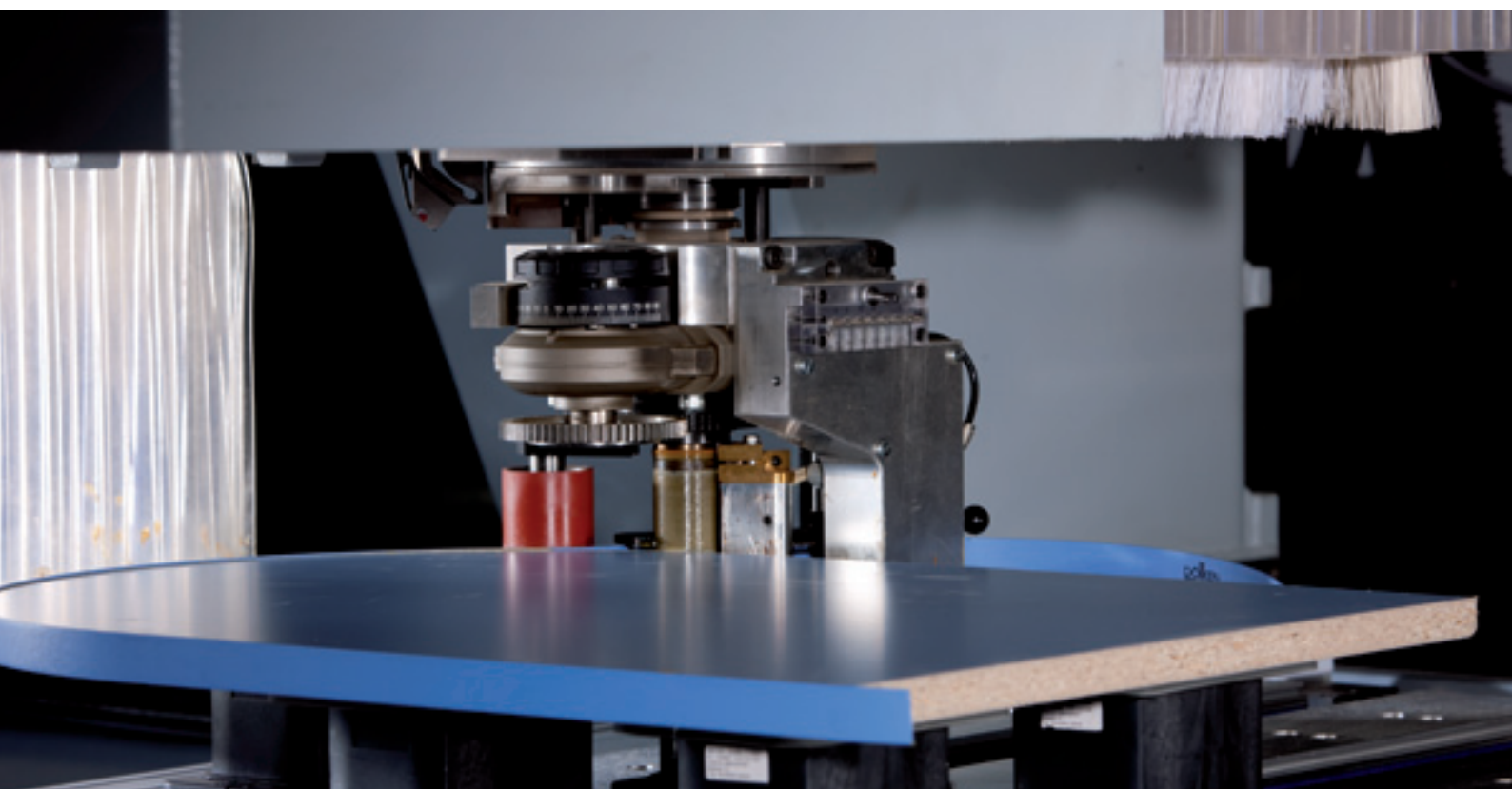

As individual as your requirements

Choose from three equipment packages for your Venture 313:

The basic package









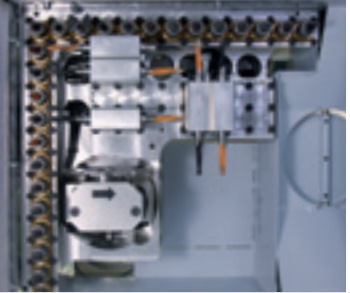

Low-cost entry into gluing technology and FLEX5 processing with full functionality.

The future package

Fast, reliable set-up of clamps with LED and high drilling output for panel processing with a larger drilling head.

The performance package

Fast, reliable setup with LED, higher output due to extra-large drilling head and additional tool changing slots.

Equipment variants	Drilling heads			Interface	
	HIGH-SPEED drilling head up to 7 500 rpm with 12 vertical spindles, grooving saw and 4 horizontal spindles with 0/90° swivel facility. Fast drilling including grooving in the X/Y direction.	HIGH-SPEED drilling head up to 7 500 rpm with 17 vertical spindles, grooving saw and 4 horizontal spindles with 0/90° swivel facility. Fewer drilling cycles including grooving in the X/Y direction.	HIGH-SPEED drilling head up to 7 500 rpm with 25 vertical spindles, 6 horizontal spindles in the X direction and 4 in the Y direction including grooving in the X direction.	The integrated interface allows the FLEX5 or FLEX5+ unit to be retrofitted at any time. For precise processing operations at "any" angle without manual settings.	
					
Basic					
Future					
Performance					



easyEdge gluing package

easyEdge gluing unit for efficient edge banding on shaped components. Ideal as a package solution in conjunction with the combination flush trimming and scraping unit.

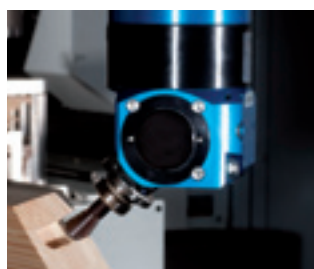

FLEX5+ unit with automatic angle adjustment and automatic tool change

Sawing, trimming, drilling at any angle in conjunction with automatic tool change. A unique feature which covers more than 90 % of five-axis applications.

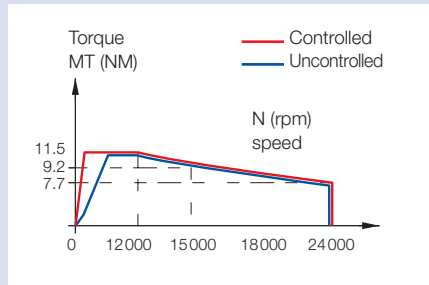

Working spindle (15 kW) with controlled spindle speed 1 000–24 000 rpm for extreme torque even at low speeds, for example when sanding.



The transmission of compressed air or fluids to units allows for instance traced units or the **easyEdge** gluing unit to be used.

Set-up aid

Suction cups are displayed using a laser beam (cross hairs). The work-piece contour can be “travelled” as a positioning aid for freeform parts.

LED displays for fast, simple positioning of vacuum clamps and consoles. Up to 70 % time savings during set-up, with correct positioning monitored “at a glance”.

Tool changer

14-slot plate changer for tools and units with a diameter of up to 200 mm. By arranging the changer below, tool change with the FLEX5+ (option) is also possible.

18-slot plate changer increases the number of tools and units which can be directly accessed and reduces set-up times. Here too, tool change is possible with the FLEX5+ (option).

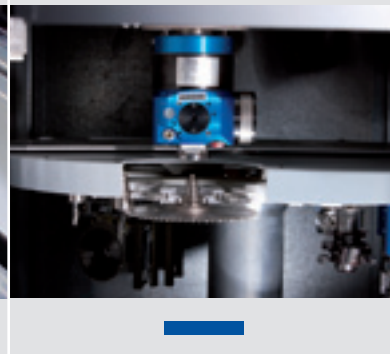

Linear changer

Additional tool change magazine, laterally mounted with 9 slots and integrated tool transfer station. Optional pickup station for the edge banding unit **easyEdge**.

Technical data

Model	X = Workpiece length [mm]			Y = Workpiece width [mm]			Workpiece thickness [mm]
	All units	With tool diameter 25 mm	With tool diameter 25 mm	All units			
	Individual processing (X1)	Alternating processing* (X2)	Alternating processing*	Rear stop	Rear stop	Front stop	From console
Venture 313 M	3,300 129.9"	1,025 40.4"	1,200 47.2"	1,550 61.0"	1,400 55.1"	1,050 37.4"	250 9.8"
Venture 313 L	4,200 165.4"	1,475 58.1"	1,650 65.0"	1,550 61.0"	1,400 55.1"	1,050 37.4"	250 9.8"
Venture 313 XXL	6,000 236.2"	2,375 93.5"	2,550 100.4"	1,550 61.0"	1,400 55.1"	1,050 37.4"	250 9.8"

* Dimension with central division. Large alternating field dynamically adapted to component size.

Technical data and photos are not binding in every detail. We reserve the express right to make changes in the interests of further development.

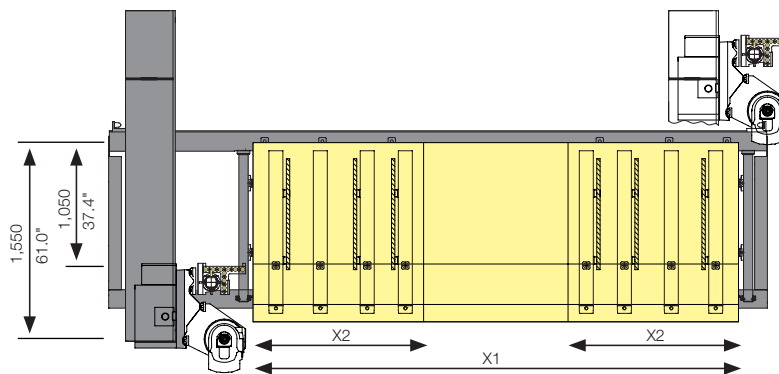

X1 = Single workpiece processing
X2 = Alternating workpiece processing

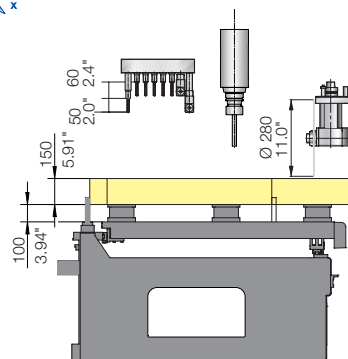
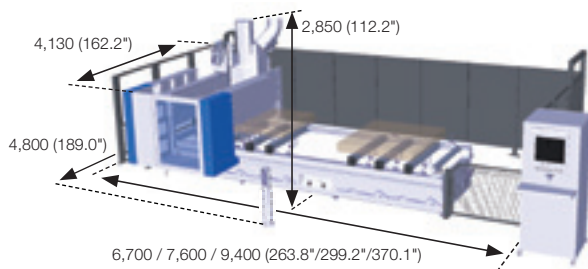
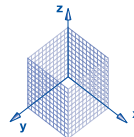

A member of the HOMAG Group



HOMAG Holzbearbeitungssysteme GmbH
 Homagstraße 3-5
 72296 SCHOPFLOCH
 GERMANY
 Tel. +49 7443 13-0
 Fax +49 7443 13-2300
 info@homag.de
 www.homag.com