

Wadkin
BURSGREEN

16" and 24" Band Saws

16" Type MZF

24" Type BZB

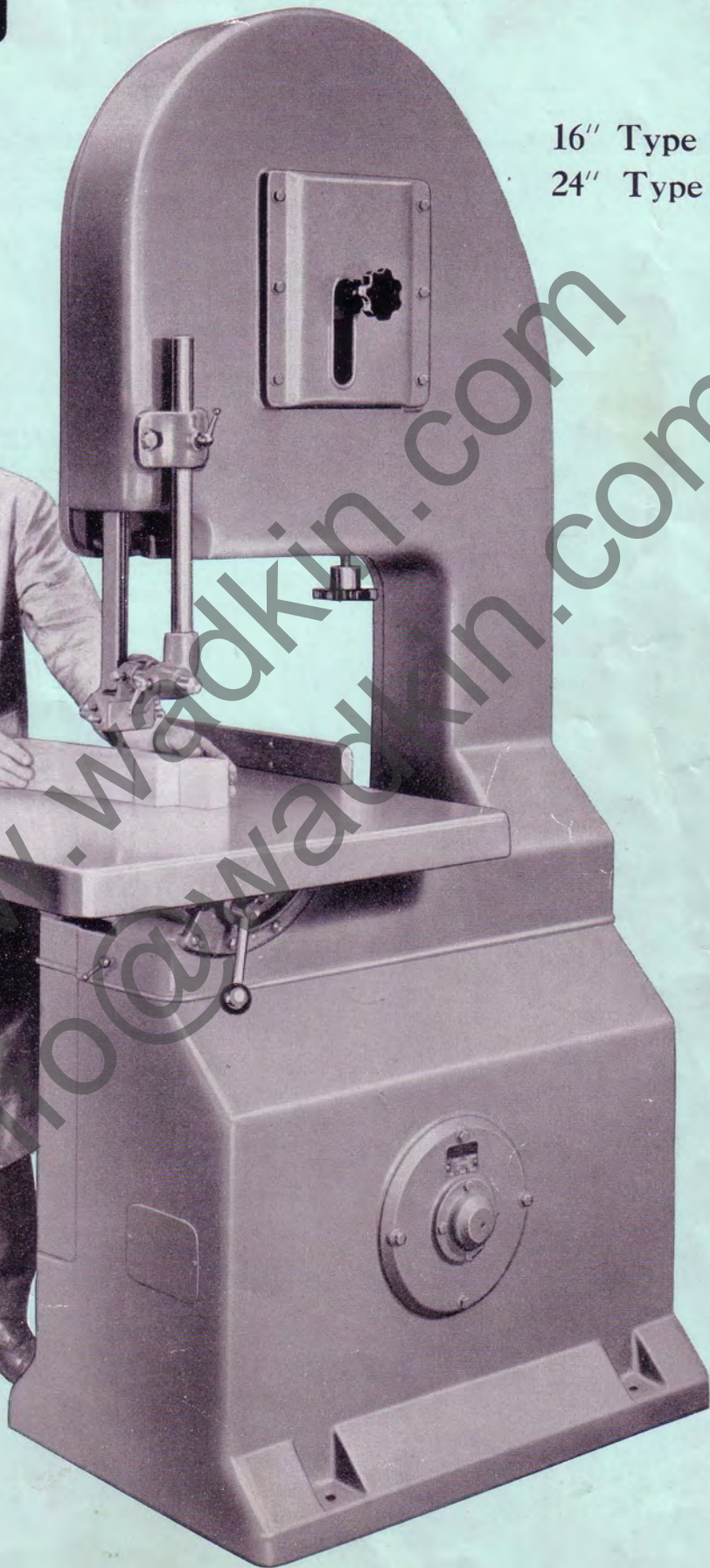

24" Bandsaw (BZB)

The Bursgreen Bandsaw is designed on robust lines, engineered on sound principles and built to exacting standards of accuracy. Its construction, allied with its many unique design features has resulted in an exceptionally smooth, free running machine, capable of the best class of sawing. To the operator the convenience of access to the saw, the enclosed working parts entailing minimum attention and maintenance, and the all round ease and convenience of operating, make this an attractive machine to use. This enables a big volume of work to be handled with the minimum of time and effort.



MAIN FRAME

is of heavy cast iron, substantially ribbed to give maximum strength and stability for high speed work. The two aluminium access doors completely enclose the machine and blade (except for the portion being used) when the machine is in operation.

SAW PULLEYS

are made from a high grade aluminium alloy accurately machined and balanced for true running. They are detachable and interchangeable and are fitted with rubber tyres securely vulcanised to the rims. Both wheels revolve on Sealed type Ball Bearings which require no lubrication by the user throughout their entire and very long life. The Top Wheel is adjustable by hand wheel and screw, whilst correct tension to the blade is ensured by the spring loaded slide which is also arranged to cant for tracking purposes. The Bottom Wheel is securely locked and keyed to the motor shaft on three-phase machines. An efficient lever operated brake is fitted which brings the wheels to rest with a minimum amount of time and effort. To keep the rubber tyre free from accumulating sawdust, an adjustable brush is fitted to the bottom wheel.

DUST CHUTE

is provided in the base of the main frame and is designed to keep the machine free from an accumulation of saw-dust in all circumstances and is also most convenient for connecting to a dust extraction plant if desired.

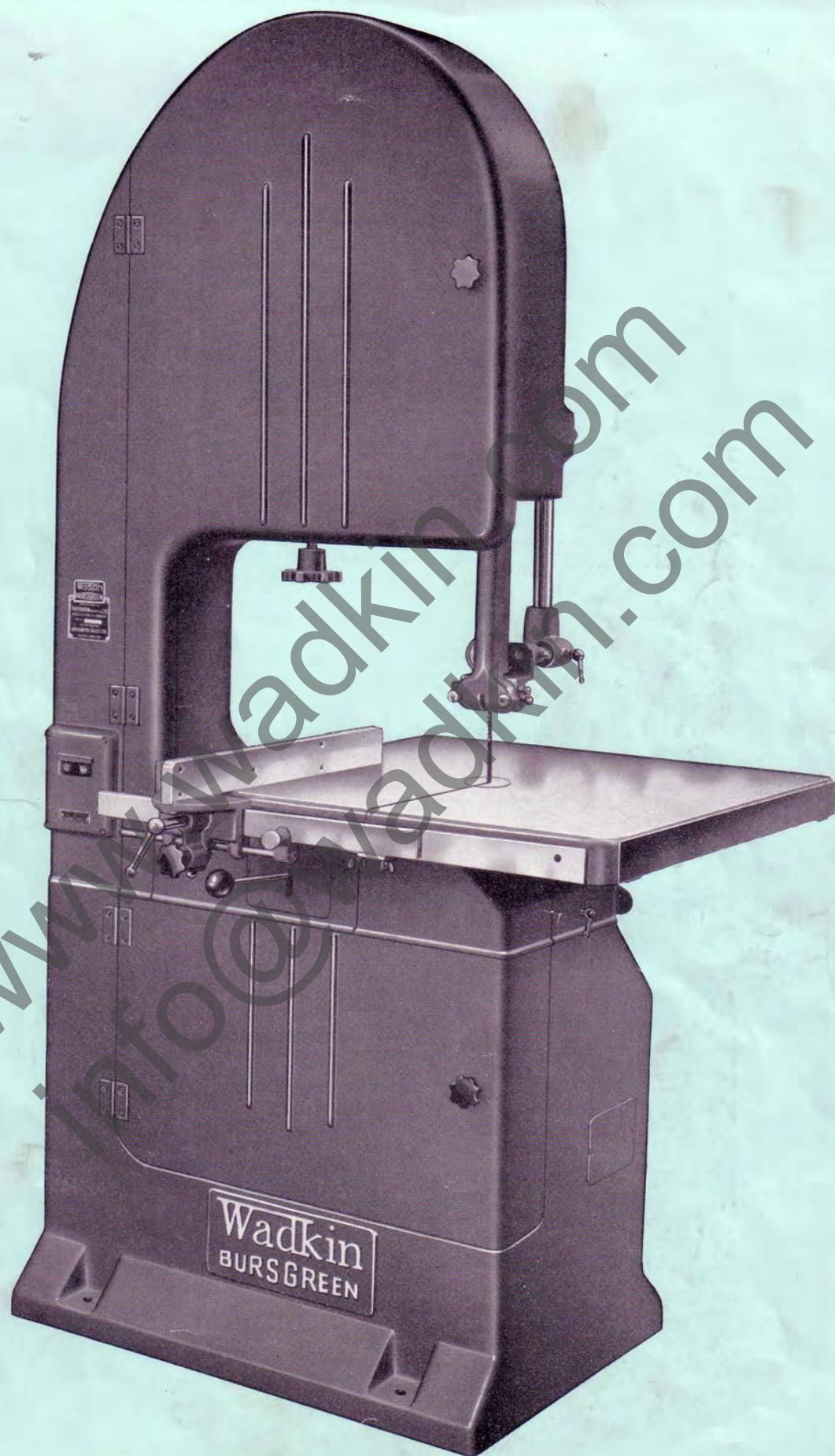

Wadkin
BURSGREEN

CANTING TABLE

is of unusually large proportions for a 24" machine being 30" square and is surface ground to a high finish. It is arranged to cant up to 45° from the horizontal. A graduated scale and efficient hand lever lock are provided.

DRIVE

The motor for all three-phase supplies is of 3 h.p. as standard and is totally enclosed in the base of the machine. The Bottom wheel is directly keyed to the motor shaft thus obviating the need for a belt drive. This motor is controlled by a Push Button operated Direct-on Contactor Starter complete with no volt and overload releases which is conveniently mounted near the operating position. An alternative arrangement can be supplied for single phase A.C. or D.C. operation.

FENCE

with rapid adjustment by hand and fine adjustment by small hand wheel can be supplied at extra cost and may be fitted on either side of the saw blade.

SAW GUIDES

are of a completely new design and are fitted above and below the table. These are supplied with an adjustable ball-bearing runner to give support to the back of the blade and are also fitted with screw adjusting bronze guide plates to give maximum support to the sides of the blade. The upper saw guide is vertically adjustable according to the thickness of timber being worked.

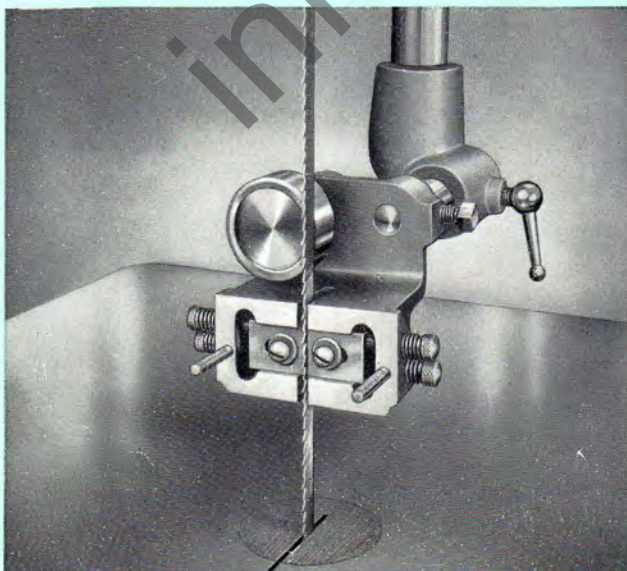
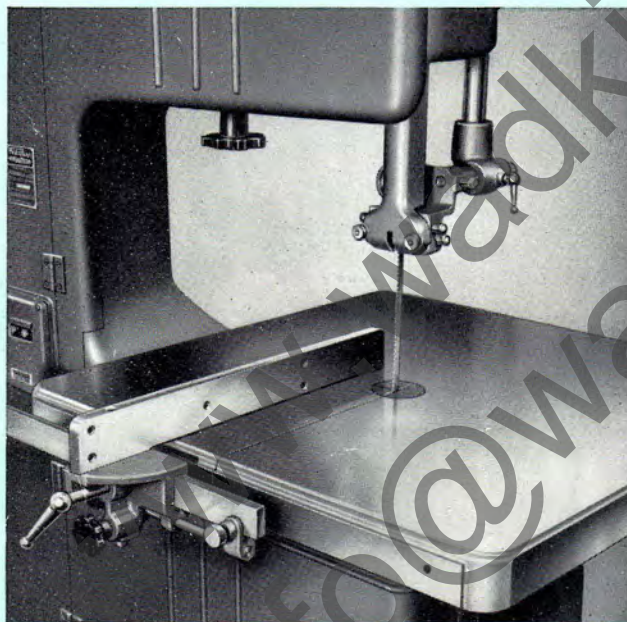
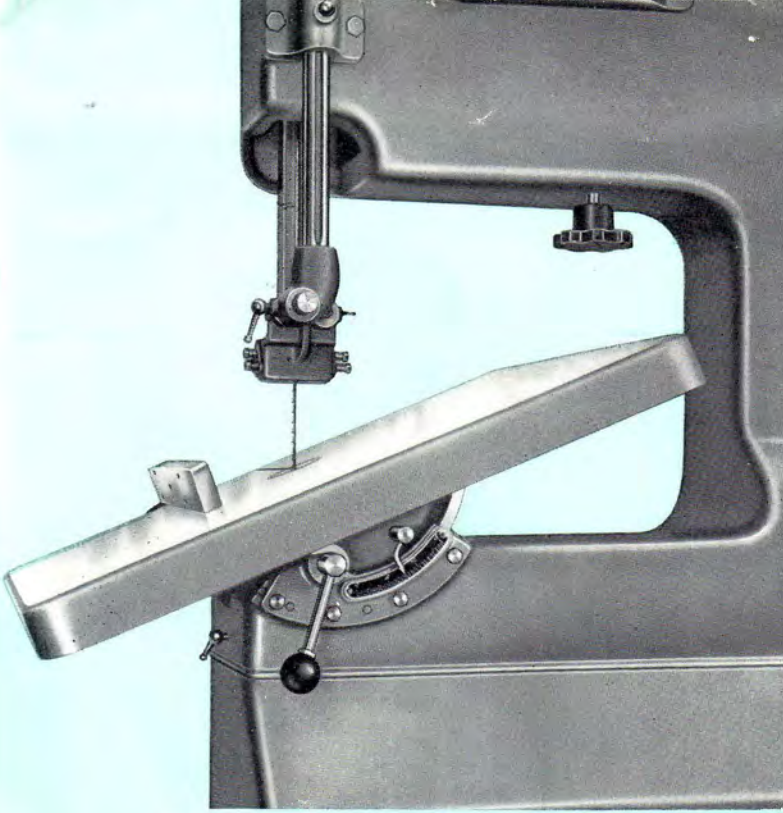

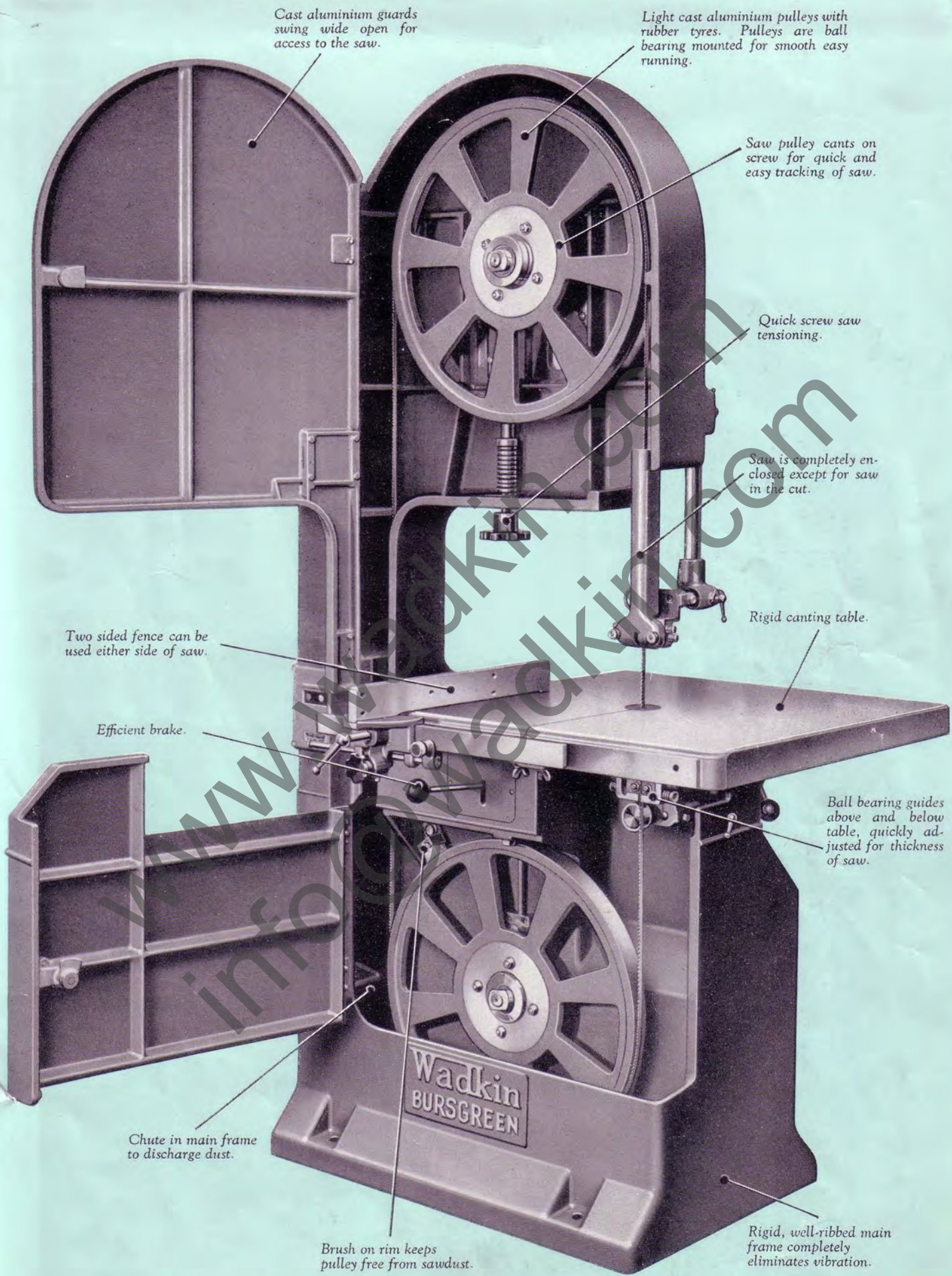

Cast aluminium guards swing wide open for access to the saw.

Light cast aluminium pulleys with rubber tyres. Pulleys are ball bearing mounted for smooth easy running.

Saw pulley cants on screw for quick and easy tracking of saw.

Quick screw saw tensioning.

Saw is completely enclosed except for saw in the cut.

Rigid canting table.

Two sided fence can be used either side of saw.

Efficient brake.

Ball bearing guides above and below table, quickly adjusted for thickness of saw.

Chute in main frame to discharge dust.

Brush on rim keeps pulley free from sawdust.

Rigid, well-ribbed main frame completely eliminates vibration.

16" Bandsaw (MZF)

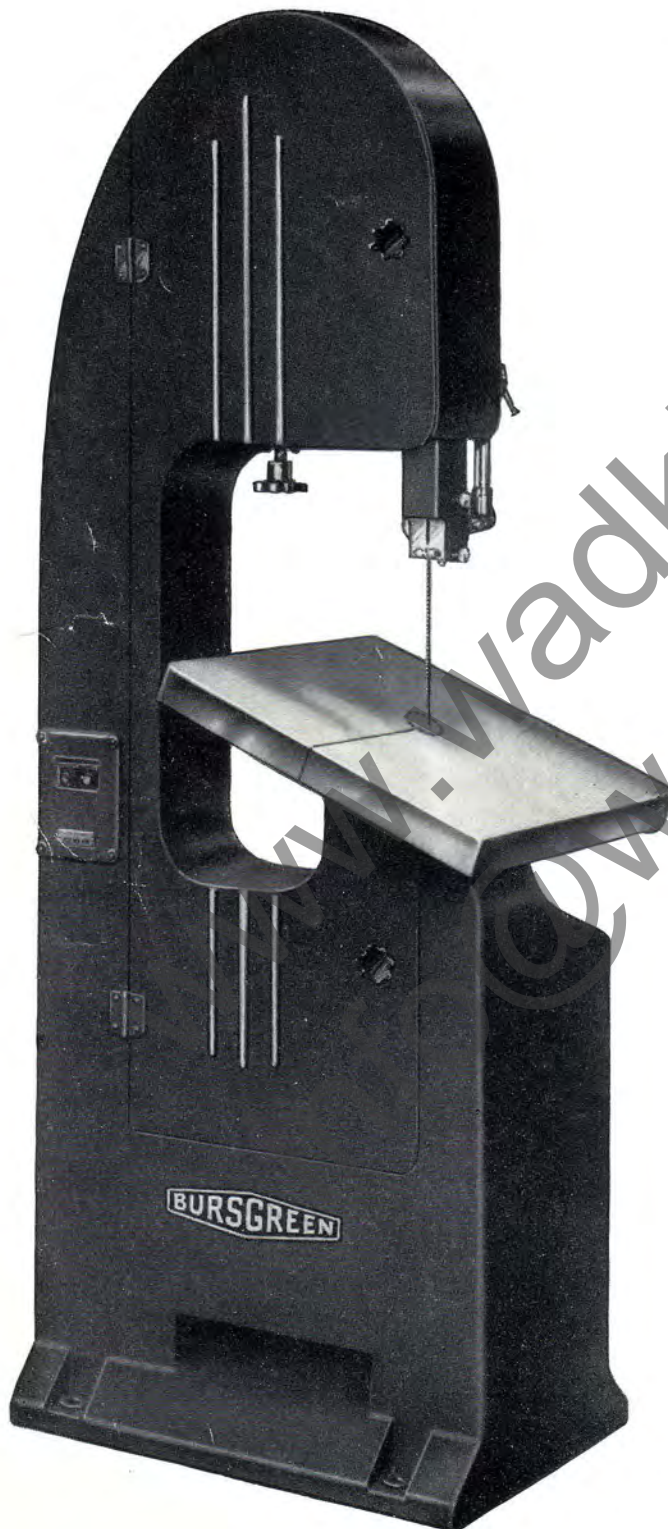

MAIN FRAME AND TABLE

The main frame for this machine is a one piece unit having a large foot area for stability. The table is mounted on strong trunnions and can be canted at any angle up to 45° from the horizontal; a calibrated scale and locking device being incorporated.

Hinged doors are provided for immediate access to the bandsaw pulleys for adjustments or bandsaw changing, etc., and, in addition, encloses all working parts.

SAW PULLEYS

Balanced, ball bearing mounted and provided with rubber tyres to give resilience and grip to the bandsaw blade. To ensure correct running of the blade and tracking the upper pulley can be canted by a handwheel.

BALL BEARING SAW GUIDES

These are fitted above and below the table level for guiding the saw blade through the table gap and to provide support during heavy cutting. The upper saw guide is vertically adjusted according to thickness of timber being worked.

SAW TENSIONING

Correct tension to the blade is obtained by means of a spring loaded compensating mechanism adjacent to the upper pulley. The unit allows re-brazed saw blades of shorter length, within certain limits (from 12' 0" maximum to 11' 4" minimum), to be used again. This results in considerable economies on saw blade costs.

FENCE (Fitted as an extra if required)

Hand adjustment rapidly gives approximate positioning, and fine adjustment is obtained by a handwheel.

CLEANING BRUSH

To keep the pulley tyres and blade free from accumulations of saw dust and ensure even running a cleaning brush is fitted to the lower pulley.

DUST CHUTE

This is incorporated in the main frame, the outlet being near the machine base. Existing dust extraction plant can be connected up if desired.

DRIVE

Squirrel cage, protected type motor, mounted in the machine base, with direct drive to the saw pulley. Control is by push button operated direct-on contactor starter complete with no-volt and overload releases.