

PRO VER KFT

NC PROCESSING CENTRE

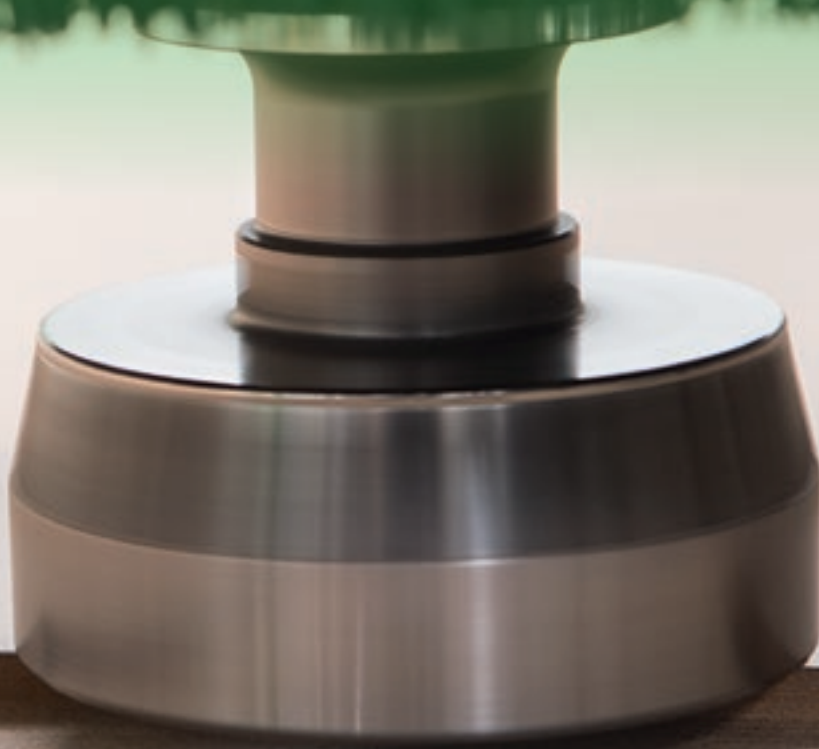

 **BIESSE**

MAXIMUM RESULTS, MINIMUM DIMENSIONS



THE MARKET EXPECTS

a change in manufacturing processes, enabling companies to **accept the largest possible number of orders**. This is coupled with the need to maintain high quality standards whilst offering product customisation **with quick and reliable delivery times**.

BIESSE RESPONDS

with simple, innovative solutions for nesting operations. **Rover K FT** is the new Biesse numerical control machining centre with Gantry structure - the most compact on the market - designed to machine panels made from wood and its derivatives. The ideal solution for artisan producers and for small and medium-sized businesses which require flexibility and ease of use within a limited production space.

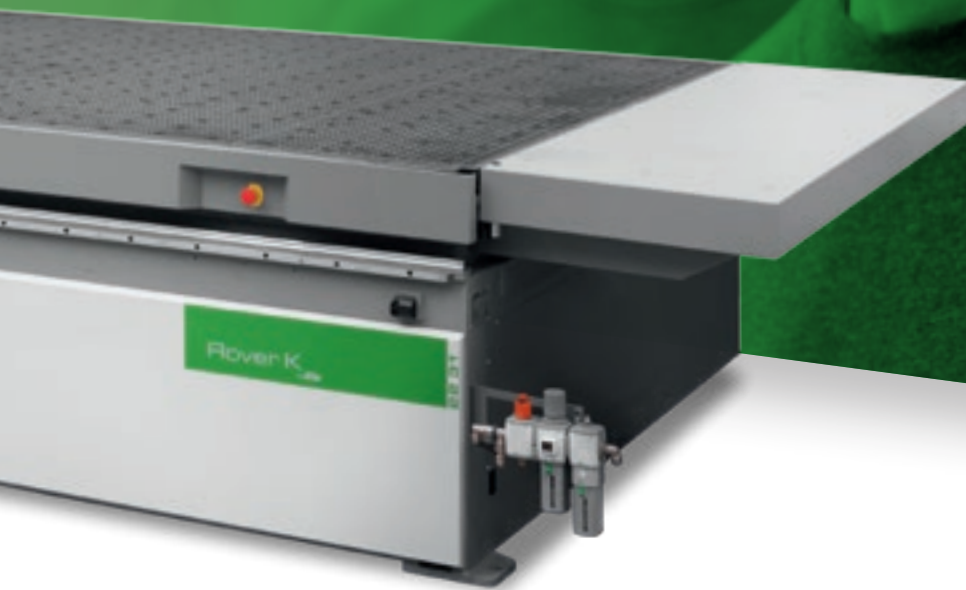

ROVER KFT

- ✔ COMPACT AND ERGONOMIC
- ✔ FAST INSTALLATION AND START-UP
- ✔ EASE OF USE
- ✔ MAXIMUM "CUSTOM" FLEXIBILITY
- ✔ ADVANCED TECHNOLOGY FOR EXCEPTIONAL FINISH QUALITY
- ✔ MAXIMUM OPERATOR SAFETY
- ✔ FULLY INTEGRATED INTO PRODUCTION FLOWS

A SINGLE WORK CENTRE FOR MANY TYPES OF MACHINING OPERATIONS



Rover K FT can carry out various types of machining operation, including: the nesting of small doors and furniture elements, scoring on solid wood, panels and doors.

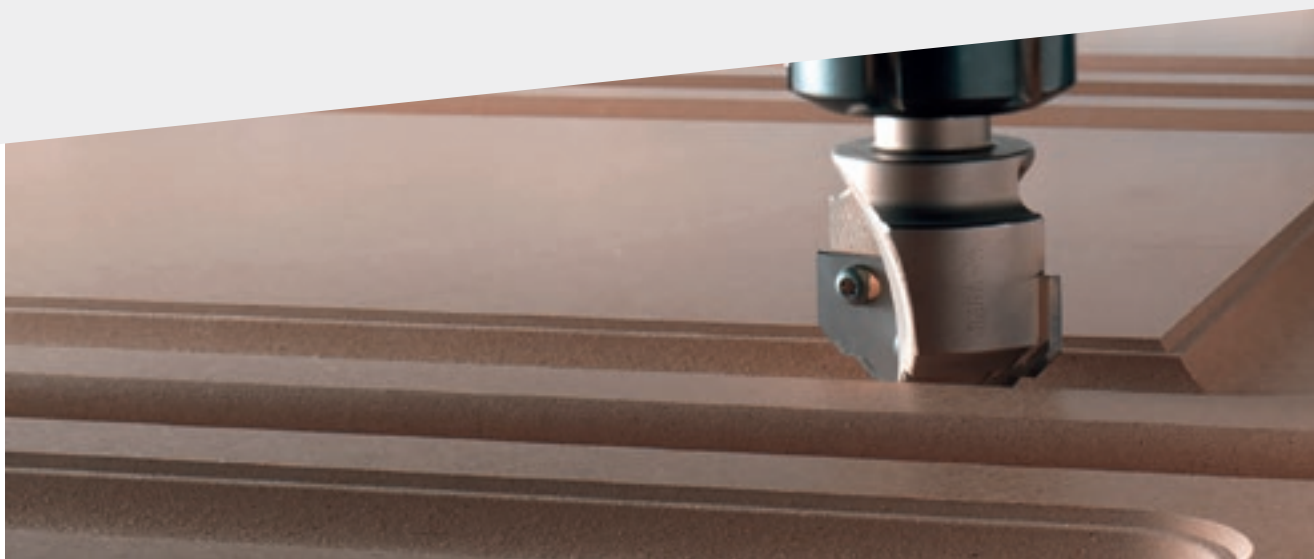

COMPACT AND ERGONOMIC



An extremely compact machining centre designed to adapt to the production space in which it is installed. Enables the operator to safely access all sides of the machine at all times, with no obstacles on the ground.

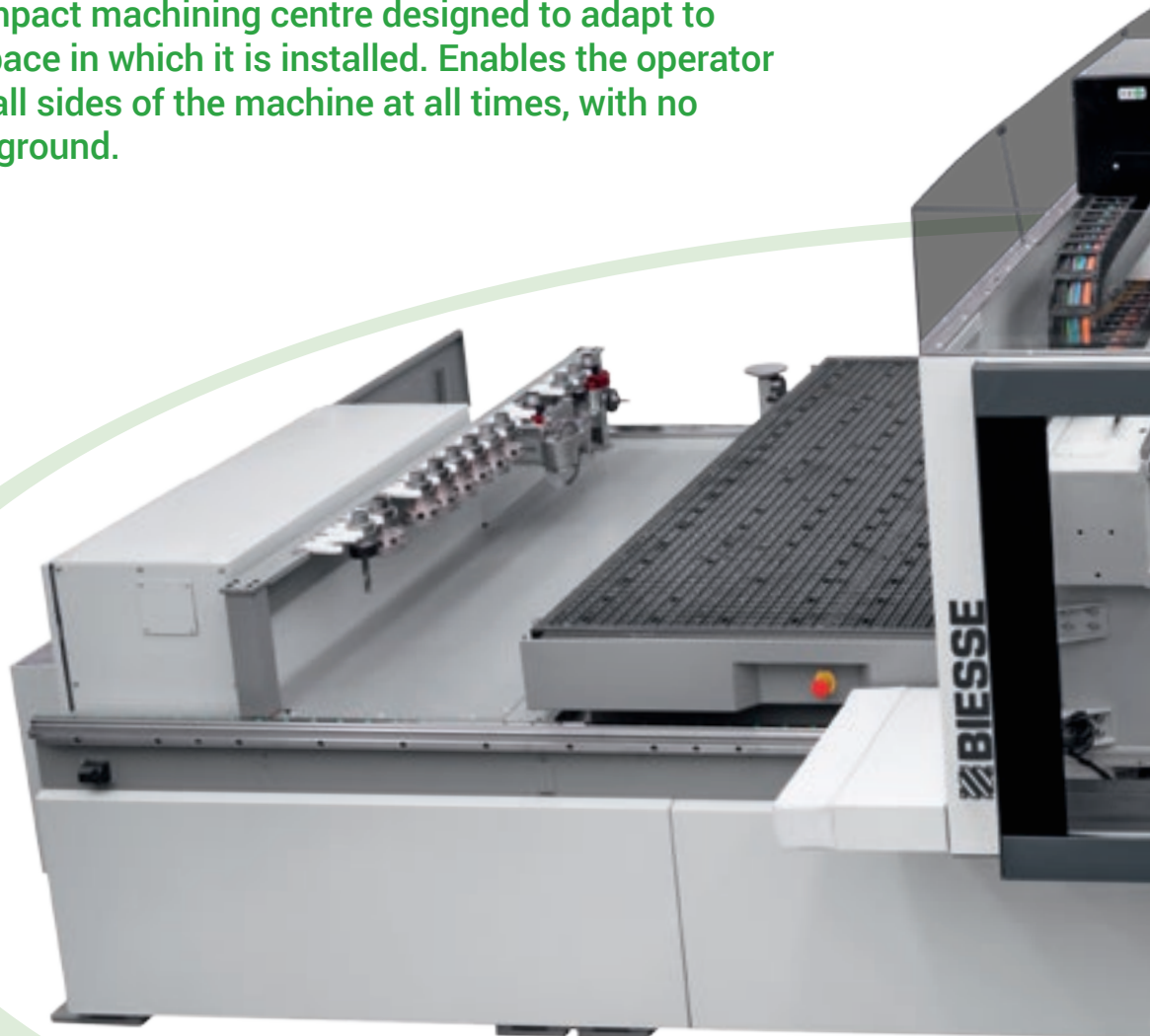

PLUG&PLAY SOLUTIONS

The new Rover K FT is designed to offer maximum performance in an extremely compact solution with the minimum working dimensions. Rover K FT represents the first of Biesse's new quick-installation plug&play solutions.

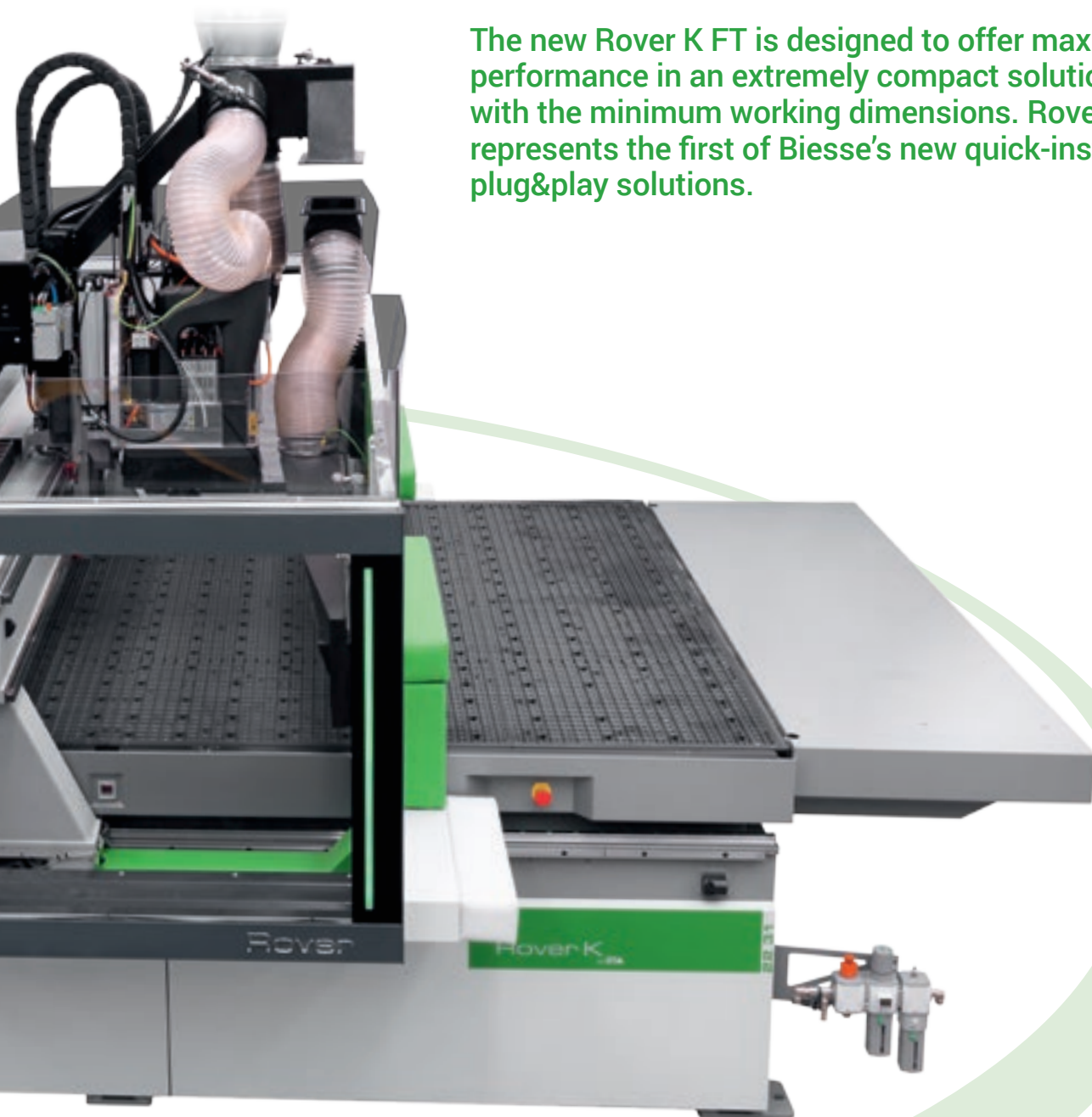

MAXIMUM CUSTOM FLEXIBILITY

The wide range of sizes available enables panels of all dimensions typical of nesting processes to be machined, enabling customers to choose the machine that best meets their needs.



Rover K FT 1224
Rover K FT 1236
Rover K FT 1531
Rover K FT 1536
Rover K FT 1836
Rover K FT 2231
Rover K FT 2243

ADVANCED WORK TABLE TECHNOLOGY TO MACHINE PANELS OF DIFFERENT TYPES AND SIZES WITH THE UTMOST RELIABILITY.

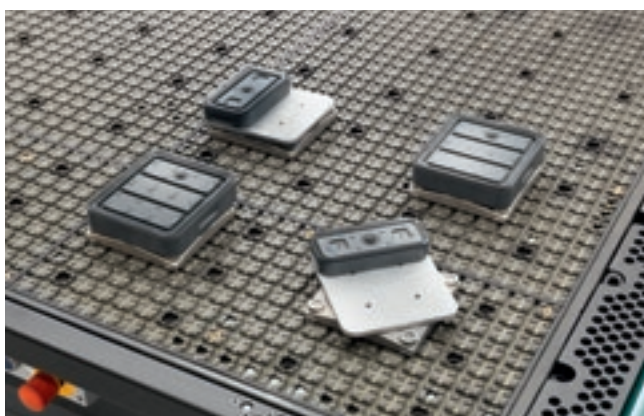

Work table in phenolic laminate with vacuum system.



The vacuum modules can be directly positioned on the support panel. The modules can be quickly and easily used, even without the auxiliary vacuum system.

MAXIMUM PANEL SECURITY THANKS TO AN ADVANCED DISTRIBUTED VACUUM SYSTEM WITHIN THE WORK TABLE.

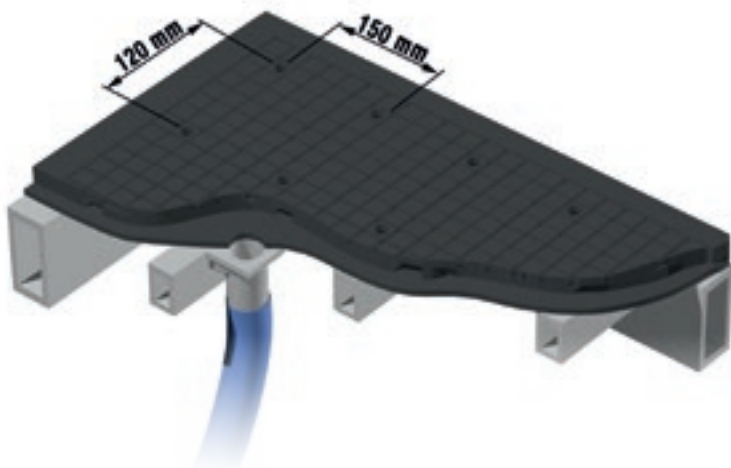

Multi-zone technology seamlessly and automatically adapts the vacuum of the machine to the different board sizes that the customer has in his production



The locking of the vacuum adapts perfectly to the panel size and enables the switching from one format to another without the need for manual operations.

NESTING MACHINING

PRODUCTIVE ECONOMY

Productivity and efficiency are increased, while maintaining high quality standards and fast delivery times.

Biesse's processing centres for nesting and carving operations allow to achieve a finished produced machined on a single, compact machine at a competitive price. The robust and well-balanced structure of the machine is ideally suited for withstanding greater processing stresses without compromising the quality of the piece and for ensuring the best finish on different types of materials.



ADVANCED TECHNOLOGY FOR EXCEPTIONAL FINISH QUALITY

The Rover K FT can be fitted with the same components used on other top-of-the-range models. The electrospindle, boring head and aggregates are designed and manufactured for Biesse by HSD, the global leader in this sector.

Up to 17-spindle maximum boring capacity with integrated blade unit.



**C AXIS TORQUE:
QUICKER, MORE
PRECISE, MORE RIGID.**



Electrospindles for every application:

- 9,0 kW HSD air cooled with automatic tool changer ISO30 and HSK F63, 1.000-24.000 rpm
- 19,2 kW HSD liquid cooled with automatic tool changer HSK F63, 1.000-24.000 rpm

Reduction of tool change set-up time and the possibility of operator error, thanks to the contact pre-setter, which automatically determines the length of the tool.



LARGE MAGAZINE CAPACITY FOR PERFORMING ALL TYPES OF MACHINING OPERATION



Tool change magazine with up to 14 spaces, rendering all tools and aggregates available at all times with no need for operator intervention when changing tooling between machining operations.



The magazine is integrated into the base, ensuring that tools are always available even when using automatic loading solutions whilst keeping overall dimensions to a minimum.

A COMPLETE RANGE OF AGGREGATES



HIGH RELIABILITY AND PRECISION OVER TIME

Rover K FT has a robust and well-balanced structure, designed to handle demanding machining requirements without compromising product quality.



The Gantry structure with dual motors is designed to increase precision and reliability standards for the execution of all nesting operations.



Automatic lubrication is an option that ensures the continuous lubrication of the machine's main moving parts without the need for operator intervention.



The air conditioning system for the standard electrical cabinet ensures that all electrical components remain reliable over time.



OPTIMAL CLEANING OF MACHINED COMPONENTS AND WORK AREA

Various optional solutions are available for cleaning the panel and the area around the machine, thus saving time for the operator.



Adjustable suction hood with 6 settings.



Adjustable suction hood with 6 settings.

The **sweeper arm** with integrated suction supports the simultaneous cleaning and unloading of panels, avoiding manual intervention and thus increasing productivity.



Chip removal system positioned between the machine and the unloading belt, guaranteeing optimal panel cleanliness.

Dust **collector positioned** at the end of outfeed belt conveyor. The new design assure the maximum cleanness also during multiple panels machining.

LOADING AND UNLOADING SOLUTIONS

Automatic loading/
unloading solutions enable
significant increases in
productivity.



Panel loading system with scissor lift
and manual or automatic panel align-
ment. The system's ease of use ensures
long term reliability.

SPECIFIC SOLUTIONS FOR MANAGING POROUS AND THIN MATERIALS

The new **system for the detachment** and automatic alignment allows the management of porous, thin up to 3mm thickness and glued panels.



The loading unit with suction cups allows the panel to be automatically loaded and positioned on the work table.



Sweep arm with adjustable blade and copying system. The device allows the automatic offloading of panels up to 3mm thickness.

INCREASING MANUFACTURING CAPACITY

The **new Roller hold-down** unit supports the multiple panels machining. Thanks to the compact design, the device can be automatically positioned inside the operating group guard without any limit to the use of operating groups.



The loop presser supports the machining of curved and stacked panels by applying pressure to the upper surface of the panel.



Biesse boasts extensive experience in the machining of breathable materials arranged in overlapping sheets.

FULLY INTEGRATED INTO PRODUCTION FLOWS

Rover K FT can be easily adapted according to work flow and in line with customer requirements.

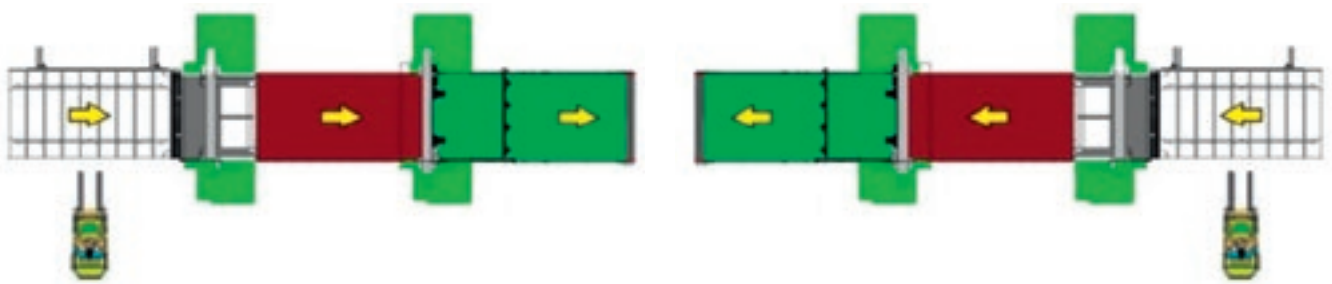

Automatic simultaneous loading/unloading solutions enable significant increases in productivity.



Panel identification and traceability with in the production flow thanks to on-demand labelling system.

INCREASING MANUFACTURING CAPACITY

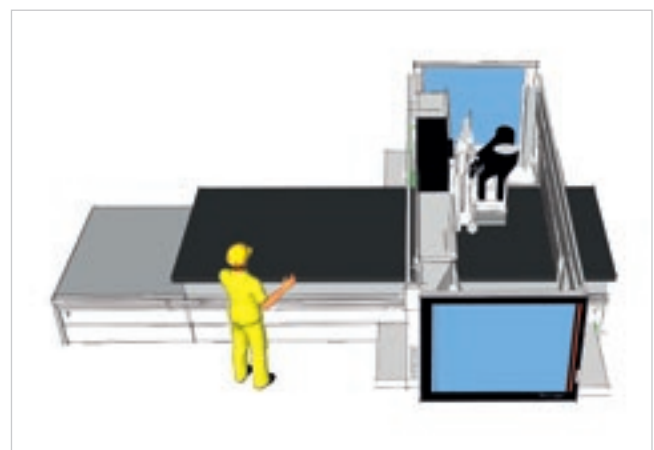

The machine can be configured with tandem loading in order to alternately process panels on opposite origins. This allows loading and unloading to be carried out while the machine is actually running.

INTE GRA TION

CONTINUOUS EVOLUTION

Integrated lines and robotised cells constantly redesign the production methods of tomorrow.

Biesse technologies are increasingly sophisticated but always user-friendly, able to maximise the competitiveness of customers wanting to increase their productivity but with reduced times and costs. Rover K FT combines perfectly with the entire range of Biesse automatic Winstore magazines, guaranteeing optimum flexibility, excellent performance and easy use to meet every possible need.



MAXIMUM ERGONOMICS AND SAFETY FOR THE OPERATOR

Biesse machines are designed to enable operators to work in complete safety.

Total protection of the working unit. The wide hatch provides maximum visibility of the machining operations, as well as ensuring easy access to the working units.

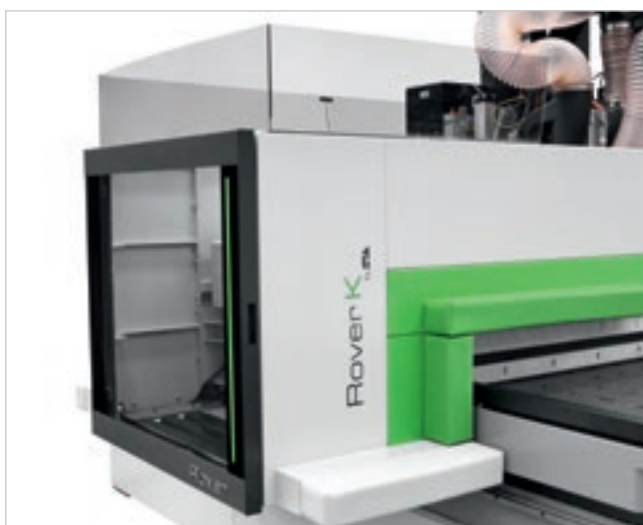

The new full bumper solution enables the operator to safely access the work table at all times from any side of the machine.



Overlapping lateral curtain guards protect the working unit.

TECHNOLOGY AT THE SERVICE OF THE USER



New console with Windows real-time operating system and bSolid software interface, including anti-collision system.

MAXIMUM VISIBILITY OF THE WORKING UNIT FROM ANY POSITION

LED bar with 5 colours, indicating the machine status in real time, allowing the operator to check the machine status at any point.

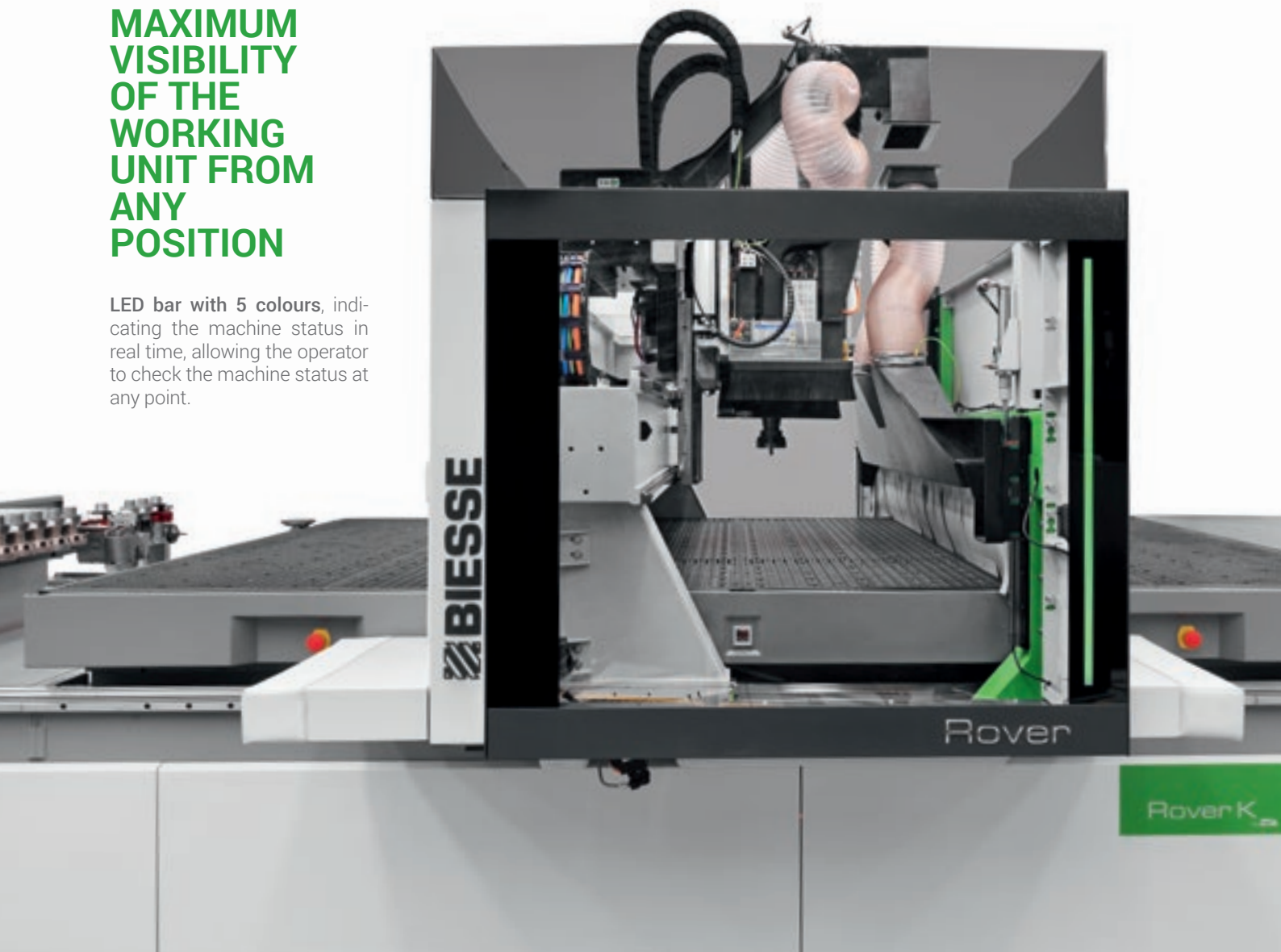

THE MOST ADVANCED TECHNOLOGY CLOSE AT HAND



BPAD

Wi-Fi control console for performing the key functions required during the preparation of the working area and the tooling of the working units and tool holder warehouses.

The bPad is a valuable tool for supporting teleservicing, courtesy of the camera and bar code reader functions.



BTOUCH

The new 21.5" touch screen which enables you to carry out all of the functions previously performed using the mouse and the keyboard, enhancing the direct interaction between the user and the device. Perfectly integrated with the bSuite 3.0 interface (and with later versions) and optimised for touch, this solution is incredibly simple, and makes the best possible use of the Biesse software functions installed on the machine.

BPAD AND BTOUCH ARE AN OPTIONAL FEATURE WHICH CAN ALSO BE BOUGHT AFTER PURCHASING THE MACHINE, IN ORDER TO IMPROVE THE FUNCTIONALITY AND APPLICATION OF THE TECHNOLOGY AVAILABLE.

INDUSTRY 4.0 READY



Industry 4.0 is the new industry frontier, based on digital technologies and on machines that speak to companies. The products driving this revolution can communicate and interact independently within production processes, which in turn are connected via intelligent networks.



Biesse is dedicated to transforming the factories owned by our customers into real-time factories that are ready to provide digital manufacturing opportunities. Intelligent machines and software become indispensable tools that facilitate the daily work of those who machine wood and other materials on a daily basis.

HIGH-TECH BECOMES ACCESSIBLE AND INTUITIVE



B_SOLID IS A 3D CAD CAM SOFTWARE PROGRAM THAT SUPPORTS THE PERFORMANCE OF ANY MACHINING OPERATION THANKS TO VERTICAL MODULES DESIGNED FOR SPECIFIC MANUFACTURING PROCESSES.

- Planning in just a few clicks, with endless possibilities.
- Simulating machining operations to visualise the piece ahead of manufacturing and have some guidance for the planning phase.
- Virtual prototyping of the piece to avoid collisions and ensure optimal machine equipment.
- Machining operation simulation with a calculation of the execution time.



B_SOLID

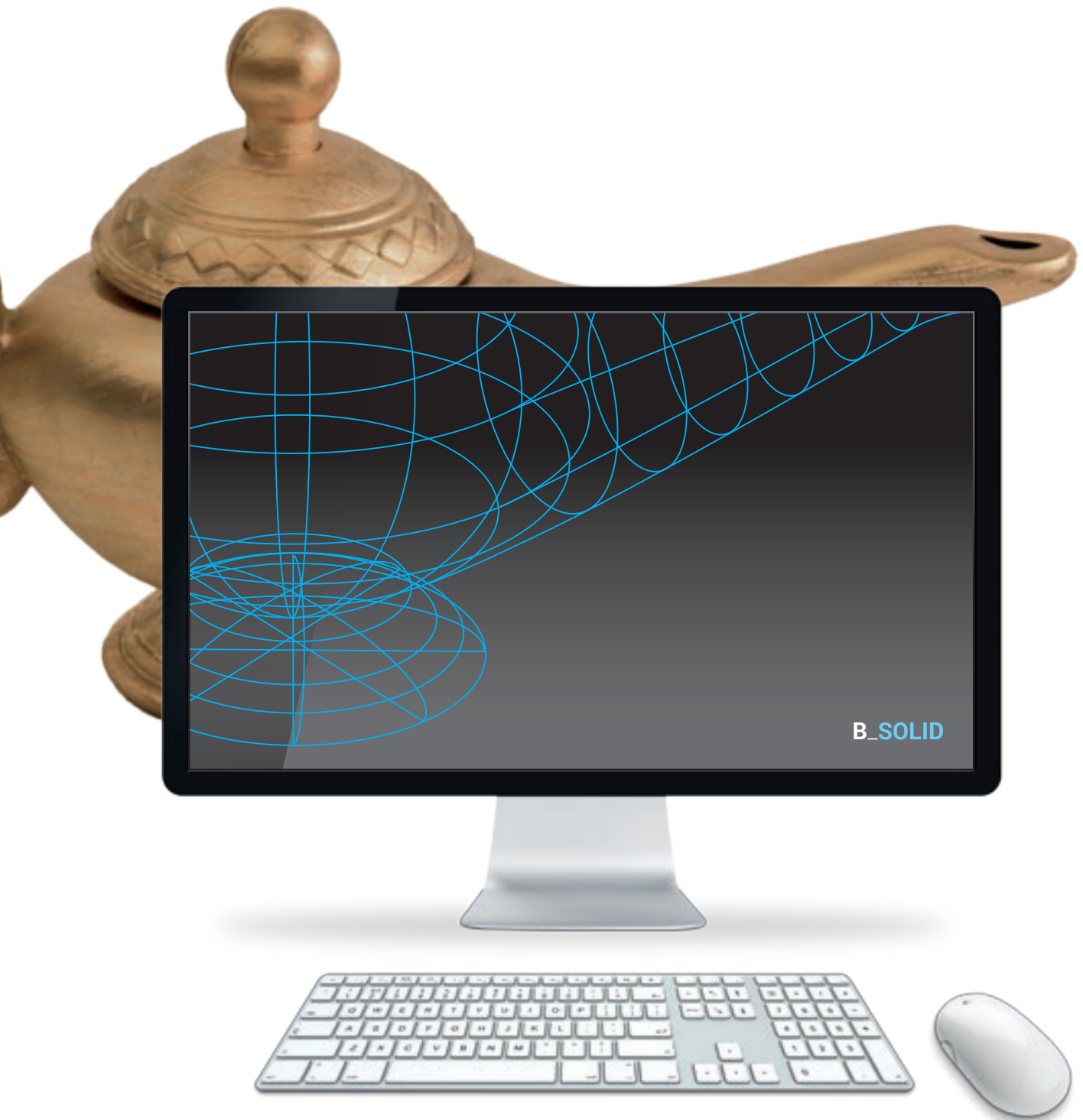

REDUCED TIME AND WASTE



B_NEST IS THE BSUITE PLUGIN SPECIFICALLY FOR NESTING OPERATIONS. IT ALLOWS YOU TO ORGANISE YOUR NESTING PROJECTS IN A SIMPLE WAY, REDUCING THE MATERIAL WASTE AND MACHINING TIMES.

- Reduced production costs.
- Simplified work for the operator.
- Integration with company software.





IDEAS TAKE FORM AND SHAPE



B_CABINET IS A UNIQUE SOLUTION FOR MANAGING FURNITURE PRODUCTION FROM THE 3D DESIGN PHASE TO PRODUCTION FLOW MONITORING.

IT'S NOW POSSIBLE TO PLAN THE DESIGN OF A SPACE AND QUICKLY PASS FROM CREATING THE SINGLE ELEMENTS TO GENERATING PHOTO-REALISTIC CATALOGUE IMAGES, FROM GENERATING TECHNICAL PRINTS TO PRODUCING REQUIREMENT REPORTS, AND ALL IN ONE SINGLE ENVIRONMENT.

B_CABINET FOUR (SUPPLEMENTARY MODULE) MAKES IT EASY TO MANAGE ALL THE WORK PHASES (CUTTING, MILLING, BORING, EDGEBANDING, ASSEMBLY, PACKAGING), JUST WITH A CLICK.

B_CABINET FOUR INCLUDES AN ENVIRONMENT DEDICATED TO THE REAL TIME MONITORING OF THE PROGRESS OF THE PRODUCTION PHASES. THAT MEANS COMPLETE CONTROL OF THE ORDER STATUS, STEP BY STEP, THANKS TO CHARTS AND 3D IMAGES.

B_CABINET



TECHNICAL DATA

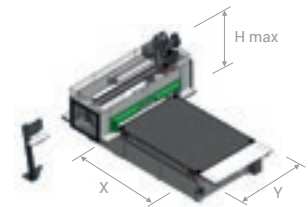

WORKING FIELD

		X	Y	Z	
				WITHOUT / WITH SWEEPER ARM	WITH ROLLERS HOLD-DOWN UNIT
ROVER K FT 1224	mm / inch	2465 / 97	1260 / 50	170 / 7	90 / 4
ROVER K FT 1236	mm / inch	3765 / 148	1260 / 50	170 / 7	90 / 4
ROVER K FT 1531	mm / inch	3100 / 122	1560 / 61	170 / 7	90 / 4
ROVER K FT 1536	mm / inch	3765 / 148	1560 / 61	170 / 7	90 / 4
ROVER K FT 1836	mm / inch	3765 / 148	1875 / 74	170 / 7	90 / 4
ROVER K FT 2231	mm / inch	3100 / 122	2205 / 87	170 / 7	90 / 4
ROVER K FT 2243	mm / inch	4300 / 169	2205 / 87	170 / 7	90 / 4

SPEED

	X	Y	Z	
m/min foot/min	25 / 82,0	60 / 196,9	25 / 82,0	low speed
m/min foot/min	60 / 196,9	60 / 196,9	25 / 82,0	high speed

VECTOR SPEED

m/min foot/min	65 / 213,3	low speed
m/min foot/min	85 / 278,4	high speed

STAND-ALONE MACHINE 3 SIDE ACCESS

LOW SPEED

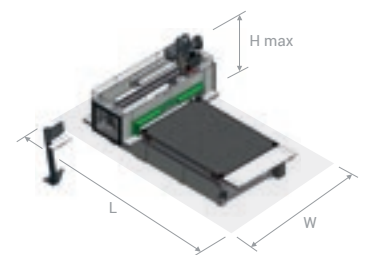

		L	W	H	H max
		NCE / CE	NCE / CE		
ROVER K FT 1224	mm / inch	6183 / 243	3955 / 156	985 / 39	2570 / 101
ROVER K FT 1236	mm / inch	7508 / 296	3955 / 156	985 / 39	2570 / 101
ROVER K FT 1531	mm / inch	6538 / 257	4256 / 168	985 / 39	2570 / 101
ROVER K FT 1536	mm / inch	7508 / 296	4256 / 168	985 / 39	2570 / 101
ROVER K FT 1836	mm / inch	7508 / 296	4581 / 180	985 / 39	2570 / 101
ROVER K FT 2231	mm / inch	6538 / 257	4911 / 193	985 / 39	2570 / 101
ROVER K FT 2243	mm / inch	7743 / 305	4911 / 193	985 / 39	2570 / 101

**MACHINE STAND ALONE,
3 SIDE ACCESS
HIGH SPEED**

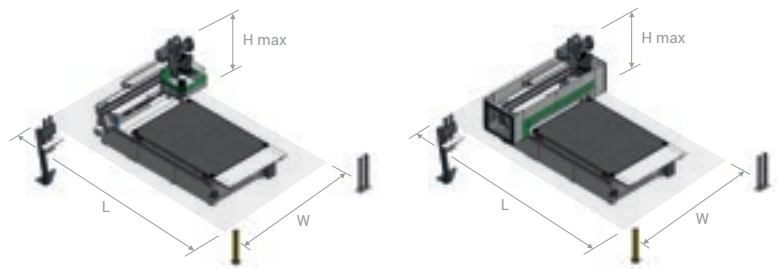

		L		W		H	H max
		NCE	CE	NCE	CE		
ROVER K FT 1224	mm / inch	6294/ 248	6310/ 248	4037/ 159	4255/ 168	985 / 39	2570 / 101
ROVER K FT 1236	mm / inch	7629/ 300	7638/ 301	4037/ 159	4255/ 168	985 / 39	2570 / 101
ROVER K FT 1531	mm / inch	6444/ 254	6590/259	4337/ 171	4660/ 183	985 / 39	2570 / 101
ROVER K FT 1536	mm / inch	7629/ 300	7638/ 301	4337/ 171	4660/ 183	985 / 39	2570 / 101
ROVER K FT 1836	mm / inch	7629/ 300	7638/ 301	4668/ 184	4910/ 193	985 / 39	2570 / 101
ROVER K FT 2231	mm / inch	6444/ 254	6590/ 259	4982/ 196	5210/ 205	985 / 39	2570 / 101
ROVER K FT 2243	mm / inch	7649/ 301	7794/ 307	4982/ 196	5210/ 205	985 / 39	2570 / 101

**MACHINE WITH ONLY
OFFLOADING BELT CONVEYOR
HIGH SPEED***

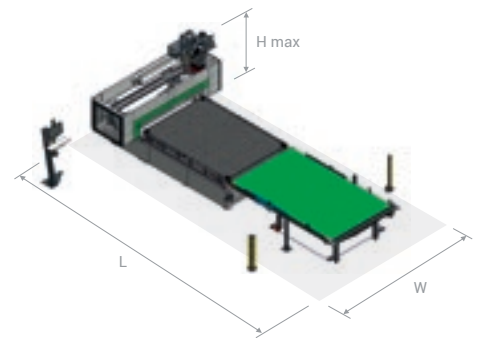

		L		W*		H	H max
		NCE	CE	NCE	CE		
ROVER K FT 1224	mm / inch	8800/ 346	8800/ 346	4055/ 160	4255/ 168	985 / 39	2570 / 101
ROVER K FT 1236	mm / inch	11310/ 445	11310/ 445	4055/ 160	4255/ 168	985 / 39	2570 / 101
ROVER K FT 1531	mm / inch	9458/ 372	9458/ 372	4556/ 179	4756/ 187	985 / 39	2570 / 101
ROVER K FT 1536	mm / inch	11310/ 445	11310/ 445	4556/ 179	4756/ 187	985 / 39	2570 / 101
ROVER K FT 1836	mm / inch	11310/ 445	11310/ 445	4481/ 176	4681/ 184	985 / 39	2570 / 101
ROVER K FT 2231	mm / inch	9458/ 372	9458/ 372	5011/ 197	5211/ 205	985 / 39	2570 / 101
ROVER K FT 2243	mm / inch	11840/ 466	11840/ 466	5011/ 197	5211/ 205	985 / 39	2570 / 101

* in case of low speed version (NCE or CE), the overall width W is 560 mm less than CE values.

**MACHINE WITH COMPLETE
NESTING CELL
HIGH SPEED**

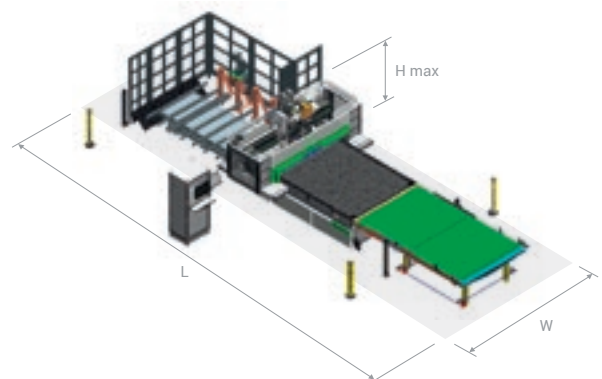

		L		W		H	H max
		NCE	CE	NCE	CE		
ROVER K FT 1224	mm / inch	10453/ 412	10453/ 412	5909/ 233	6109/ 241	985 / 39	2570 / 101
ROVER K FT 1236	mm / inch	14420/ 568	14420/ 568	5909/ 233	6109/ 241	985 / 39	2570 / 101
ROVER K FT 1531	mm / inch	12343/ 486	12343/ 486	6260/ 246	6460/ 254	985 / 39	2570 / 101
ROVER K FT 1536	mm / inch	14420/ 568	14420/ 568	6260/ 246	6460/254	985 / 39	2570 / 101
ROVER K FT 1836	mm / inch	14420/ 568	14420/ 568	6540/ 257	6740/ 265	985 / 39	2570 / 101
ROVER K FT 2231	mm / inch	12343/ 486	12343/ 486	6760/ 266	6960/ 274	985 / 39	2570 / 101
ROVER K FT 2243	mm / inch	16490/ 649	16490/ 649	6760/ 266	6960/ 274	985 / 39	2570 / 101

CONFIGURATION

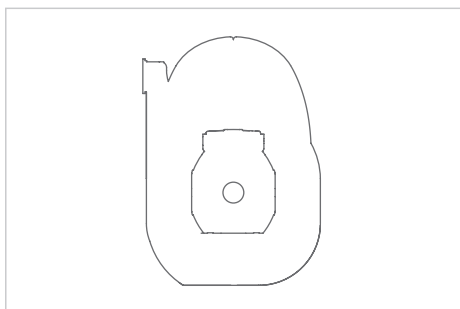

Boring heads available for all application up to 19,2 kW.

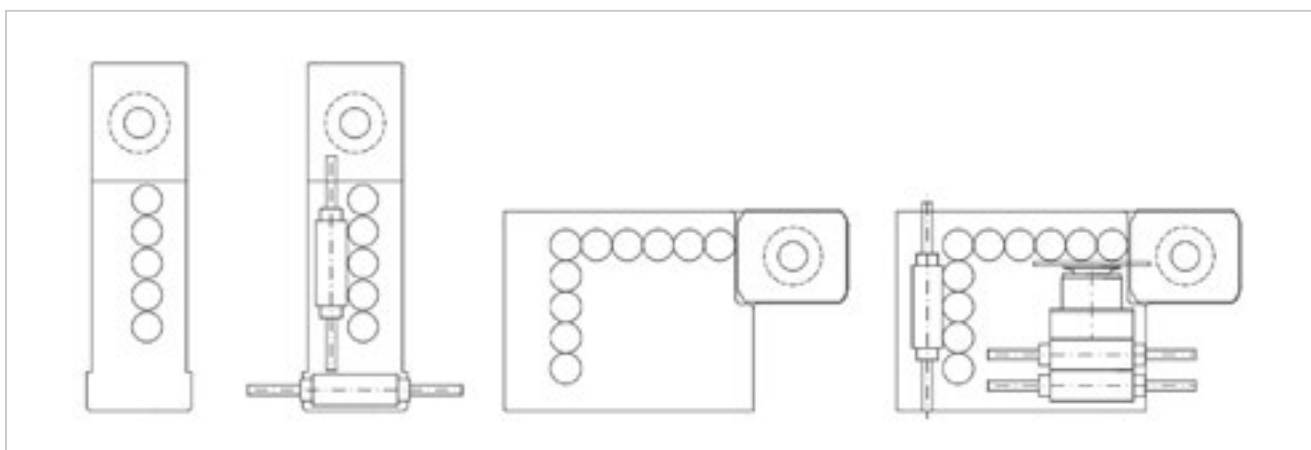

Boring heads available with 5 to 17 positions: BH5 - BH9 - BH10 - BH17 L.

The technical specifications and drawings are non-binding. Some photos may show machines equipped with optional features. Biesse Spa reserves the right to carry out modifications without prior notice.

Weighted sound pressure level A (LpA) during machining at the operator's workstation on the vane-pump machine Lpa=79dB(A) Lwa=96dB(A) Weighted sound-pressure level A (LpA) at the operator's workstation and sound power level (LwA) during machining on the cam-pump machine Lwa=83dB(A) Lwa=100dB(A) Measurement uncertainty K dB(A) 4.

The measurement was carried out in compliance with UNI EN 848-3:2007, UNI EN ISO 3746: 2009 (sound power) and UNI EN ISO 11202: 2009 (sound pressure levels at workstation) during panel machining. The noise levels shown are emission levels and do not necessarily correspond to safe operation levels. Despite the fact that there is a relationship between emission and exposure levels, this may not be used in a reliable manner to establish whether further measures need to be taken. The factors determining the exposure level for the workforce include length of exposure, work environment characteristics, other sources of dust and noise, etc. i.e. the number of other adjoining machines and processes. At any rate, the above information will enable the operator to better evaluate dangers and risks.

SOPHIA

GREATER VALUE FROM MACHINES

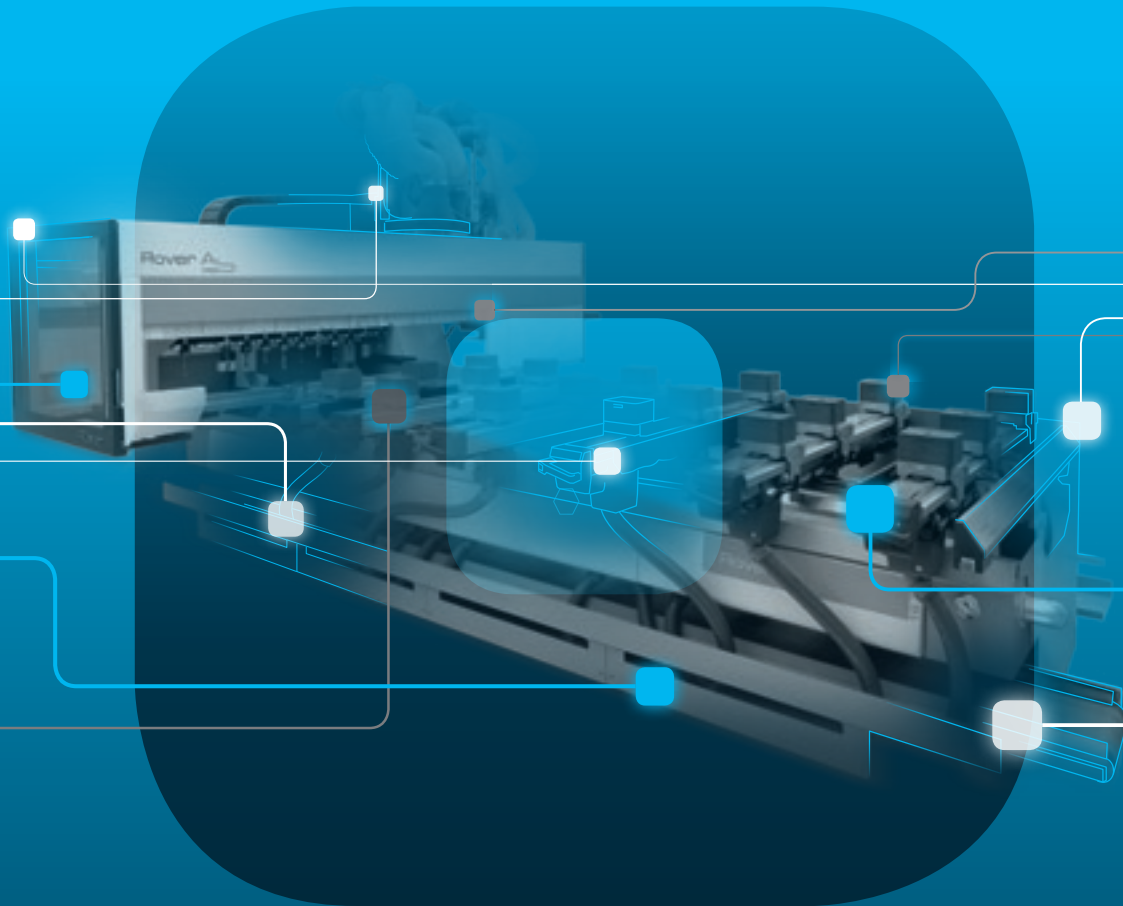

The Biesse IoT platform which enables customers to access an extensive range of services to streamline and rationalise their work management processes.

□ SERVICES

□ PROACTIVITY

□ ANALYSIS

 **BIESSE**

in collaboration with  **accenture**

SERV ICE & PARTS

Direct, seamless co-ordination of service requests between Service and Parts. Support for Key Customers by dedicated Biesse personnel, either in-house and/or at the customer's site.

BIESSE SERVICE

- ✔ Machine and system installation and commissioning.
- ✔ Training centre dedicated to Biesse Field engineers, subsidiary and dealer personnel; client training directly at client's site.
- ✔ Overhaul, upgrade, repair and maintenance.
- ✔ Remote troubleshooting and diagnostics.
- ✔ Software upgrade.

500

Biesse Field engineers in Italy and worldwide.

50

Biesse engineers manning a Teleservice Centre.

550

certified Dealer engineers.

120

training courses in a variety of languages every year.

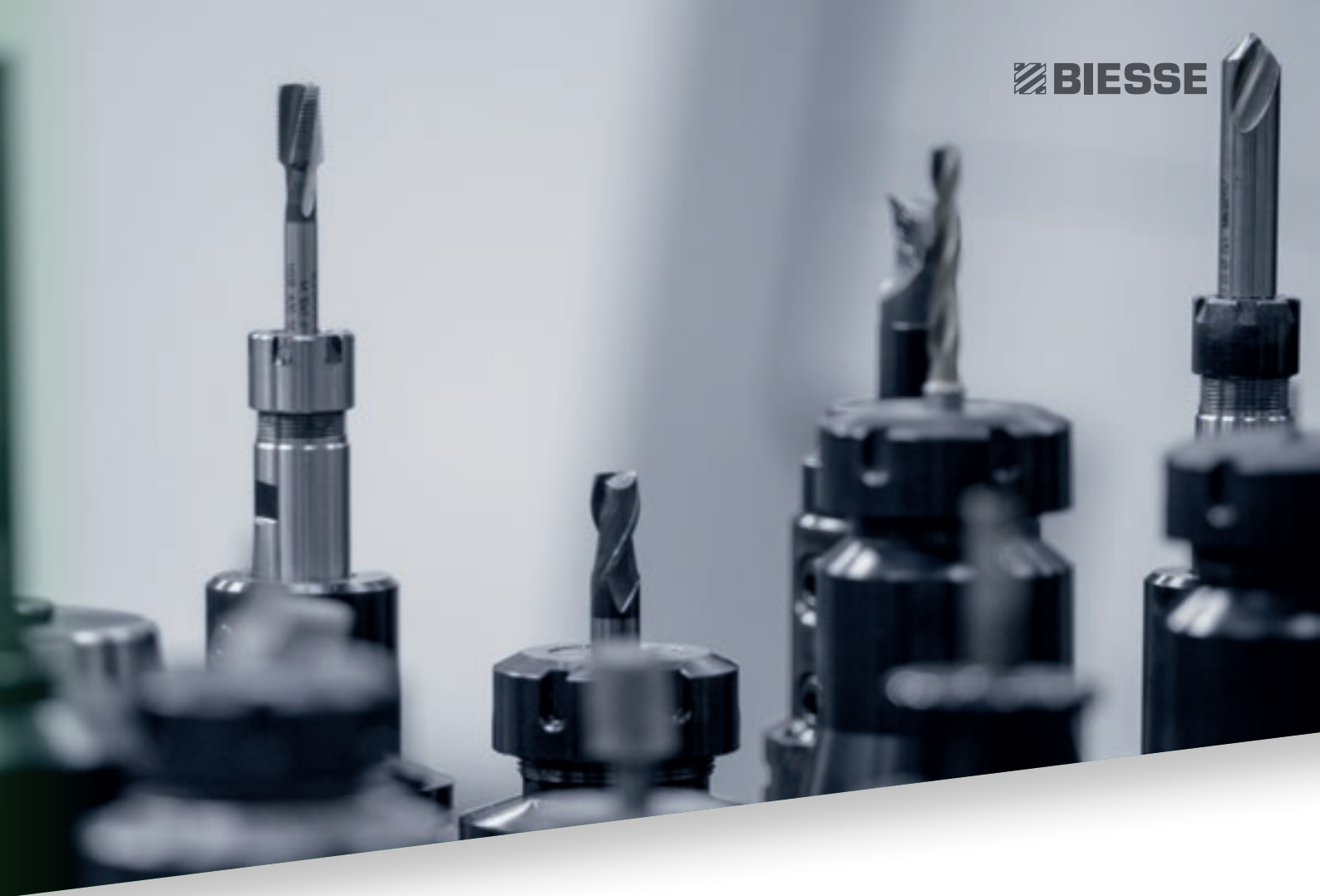
A close-up photograph of several metal drill bits and tool components, arranged in a row. The focus is sharp on the central bit, while the others are slightly blurred. The background is a soft, out-of-focus grey.

The Biesse Group promotes, nurtures and develops close and constructive relationships with customers in order to better understand their needs and improve its products and after-sales service through two dedicated areas: Biesse Service and Biesse Parts. With its global network and highly specialized team, it offers technical service and machine/component spares anywhere in the world on-site and 24/7 on-line.

BIESSE PARTS

- ✔ Original Biesse spares and spare kits customized for different machine models.
- ✔ Spare part identification support.
- ✔ Offices of DHL, UPS and GLS logistics partners located within the Biesse spare part warehouse, with multiple daily pick-ups.
- ✔ Order fulfillment time optimized thanks to a global distribution network with de-localized, automated warehouses.

92%
of downtime machine orders fulfilled
within 24 hours.

96%
of orders delivered in full on time.

100
spare part staff in Italy and worldwide.

500
orders processed every day.

MADE WITH BIESSE

MATON AND BIESSE MAKE MUSIC TOGETHER

With more than 1200 models of guitars made for thousands of professional musicians, Maton Guitars confirms its worldwide presence, becoming a truly great Australian success story. "The best guitar is the one that the market demands," states Patrick Evans, Head of Product Development at Maton. The evolution in production techniques and research into the most efficient software continues, prompting Maton to hunt for new solutions that can better respond to emerging needs. In 2008, after considering the pros and cons of a range of manufacturers, Maton chose Biesse.

Maton's production needs incorporate technological requirements and artisan skills; the right balance of these two allows them to achieve the highest levels of quality and performance. A great guitar is both a work of art and a fine musical instrument. To obtain these results, the right tools are crucial - both for heavy machining operations and delicate processes, to create 3D shapes and work with minimal tolerances. Biesse has provided Maton with a range of advanced solutions for machining processes, not only adding quality to the products, but also providing the skilled craftsmen with more time to devote to manual finishes,

ensuring that every product is unique.

In 1995, the company installed their first CNC machine. They now have two nesting centres in tandem. The Rover C is the ideal machine for high-precision nesting operations, but also for creating complex shapes, such as the body of Maton's unique guitars. The machine's newly-designed cabin provides excellent visibility of all working units. Biesse is much more than a manufacturer of machinery for producing kitchens. Their impressive range of machines can process an astounding range of materials and products. "In creative hands," commented Patrick Evans, "Biesse becomes the instrument of a true craftsman. The key is to identify the right machine for the job. We found we can accomplish much more than we thought on a Biesse machine."

Maton also uses the two Biesse machines to create new product prototypes; the most complex shapes, and almost every individual part which makes up a Maton guitar. Patrick confirms that Maton uses the Biesse CNC machine at high speeds even on the most complex parts, such as the magnificent fingerboard. "We need enough flexibility to be able to switch from one model to another

very quickly, and Biesse allows us to do this very effectively." Biesse gives users the creative freedom to produce virtually any concept, both quickly and efficiently. "With the Biesse's CNC machine," Patrick continues, "you can turn your ideas into reality much faster. Thanks to the flexibility provided by Biesse machines, we can produce two fingerboard prototypes in seven minutes! If we made them by hand, it would take a whole day. Using Biesse machines has allowed us to create eight new guitar models this year alone." Using Biesse machines has allowed Maton to devote more time to the quality of the finish, wasting less time on processing individual pieces. Each Maton guitar is handfinished by a dedicated and qualified team of luthiers. Maton has demonstrated that it is possible to produce a guitar in Australia with a worldwide reputation for quality, using Australian timber and technologies. Maton knows exactly how to design and build a unique, one-of-a-kind product, a wellmade guitar, and with Biesse as valued partner, the best guitars in the world are brought to life.

Taken from an interview with Patrick Evans, head of Product Development at Maton Guitars - Australia



LIVE THE EXPERIENCE



Interconnected technologies and advanced services that maximise efficiency and productivity, generating new skills to serve better our customer.

**LIVE THE BIESSE GROUP
EXPERIENCE AT OUR CAMPUSES
ACROSS THE WORLD.**

