

PRO VER A SMART 16

CNC MACHINING CENTRE



A CHOICE FOR THE FUTURE



THE MARKET EXPECTS

a change in manufacturing processes, enabling companies to accept the largest possible number of orders. This is coupled with the need to maintain high quality standards and product customisation with quick and defined delivery times, as well as responding to the needs of the most creative architects.

BIESSE MEETS

these requirements with technological solutions that enhance and support technical expertise as well as process and material knowledge. **Rover A Smart 16** is a simple, userfriendly 5-axis CNC machining centre for producing any type of furnishing item. It's ideally suited to both small and large joineries that need to manufacture either irregular shaped components or standard-size components in small batches.

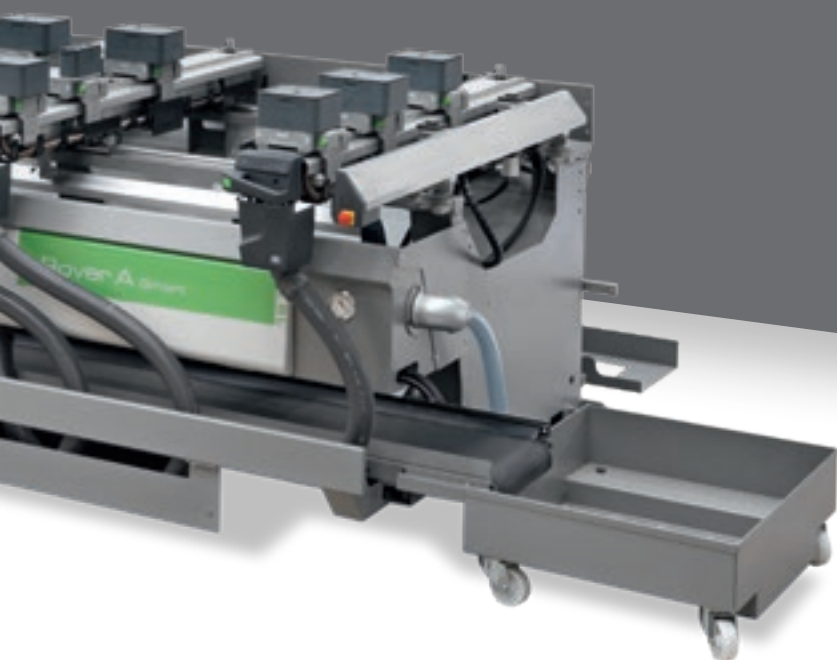

ROVER A SMART 16

- ✔ OPTIMUM PRECISION AND HIGH FINISH QUALITY
- ✔ ABILITY TO PROCESS LARGE SIZES
- ✔ REDUCED TOOL CHANGEOVER TIME
- ✔ HIGH-TECH BECOMES ACCESSIBLE AND INTUITIVE

A SINGLE PROCESSING CENTRE TO MEET EVERY PRODUCTION NEED

5-axis technology to give extra value to the finished product. Allows complex pieces to be created with the utmost simplicity, accuracy and finish quality.



OPTIMUM PRECISION AND HIGH FINISH QUALITY



The new BHZ 29 2L boring head is equipped with automatic lubrication and a highly efficient rigid suction cap for a cleaner environment. It's liquid-cooled for maximum precision.

Maximum reliability and productivity thanks to the use of first class components on all the machines of the Rover range.

Linear slide guides for the work table, for perfect positioning accuracy and stability.

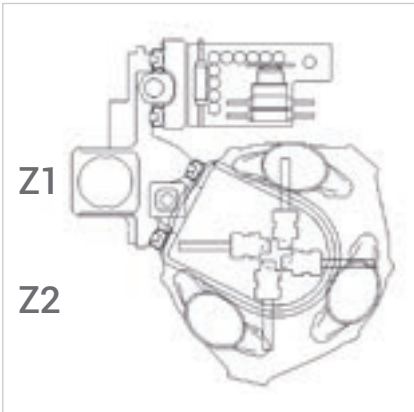

The two independent Z axes guarantee excellent machinability in Z. The high speed of the Z axis (30m/min) allows the 5-axis unit to perform machining cycles and tool changes very quickly.

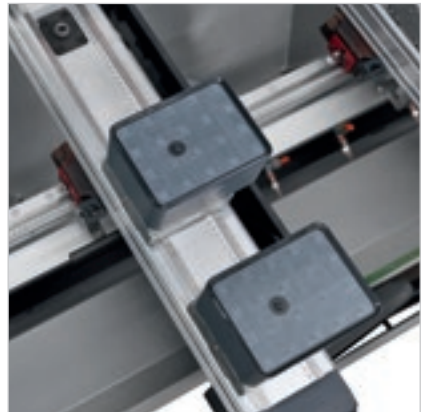

5 AXIS

USER-FRIENDLY TECHNOLOGY

The high technological content of the world's most popular machining centres, meets the requirements of wood industry professionals.

The 5-axis operating head, equipped with 13 or 16.5 kW HSD spindle and with 360° continuous rotation on the vertical and horizontal axes, enables the machining of complex-shapes ensuring quality, precision and absolute long term reliability.





ABILITY TO PROCESS LARGE SIZES

The machine can accept pieces of 245mm (the only one in its category to do so), so every job order can be accepted and pieces of considerable thickness can be machined.

THE POSSIBILITY TO LOAD PANELS WITH A DEPTH OF 1900MM MEANS THE PRE-SECTIONING PHASE CAN BE AVOIDED AND PIECES LARGER THAN THE WORKING AREA CAN BE MACHINED THANKS TO DOUBLE POSITIONING.



MAXIMUM OPERATOR SAFETY

Excellent productivity with high machining speeds, whilst ensuring absolute safety for the operator.

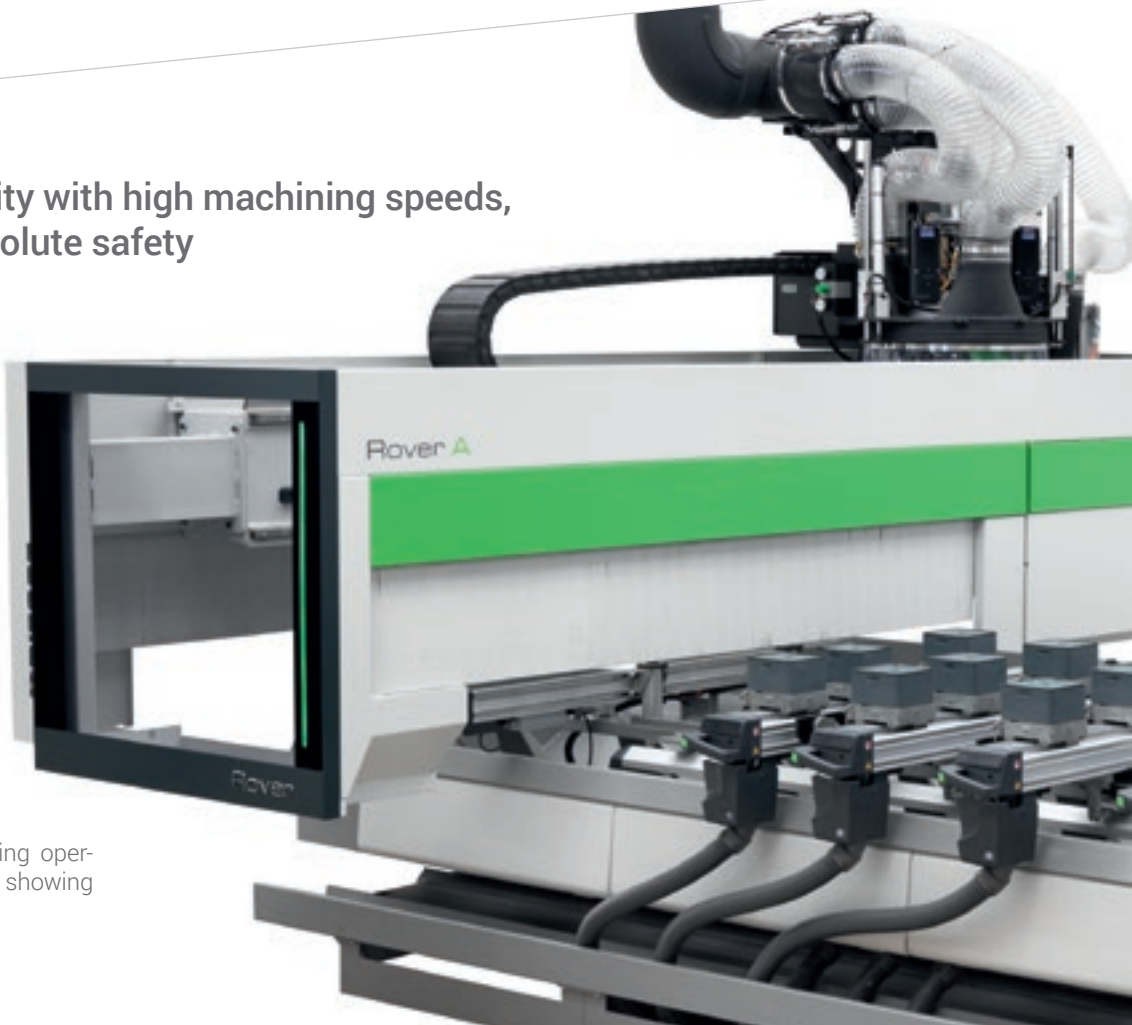

Maximum visibility of machining operation. LED bar with 5 colours showing machine status in real time.



Remote control panel for direct and immediate operator control.



Pressure-sensitive floor mats enable the machine to operate at constant maximum speed.



Side curtain guards to protect the working unit; they can be moved to enable the machine to work at maximum speed in total safety.

VECTORIAL SPEED OF 100M/MIN.

REDUCED TOOL CHANGEOVER TIME

The Biesse work table guarantees an optimum hold on the piece and quick, easy tooling.



Uniclamp

Pneumatic locking systems with quick release.



SA (Set Up Assistance)

The work table has a guided positioning function, providing the operator with suggestions on how to position the panel (indicating the position of the work tables and locking systems) and protecting the working area from the risk of collision with the tool.



16-place Revolver tool magazine on the X carriage

, so that tools and aggregates are always readily available. Equipped with a protective tool cover with automatic opening.



12-place tool magazine on the base

The tooling of the 16-place quick Revolver magazine can be automatically modified by picking up the tools from the 12-place rack magazine. This means machining can continue without hampering pendular operation. The first front position acts as a Pick-Up for tooling the Revolver magazine.

Equipped with a protective tool cover with automatic opening.



REDUCED CLEANING TIMES TO ENSURE MAXIMUM PRODUCTIVITY

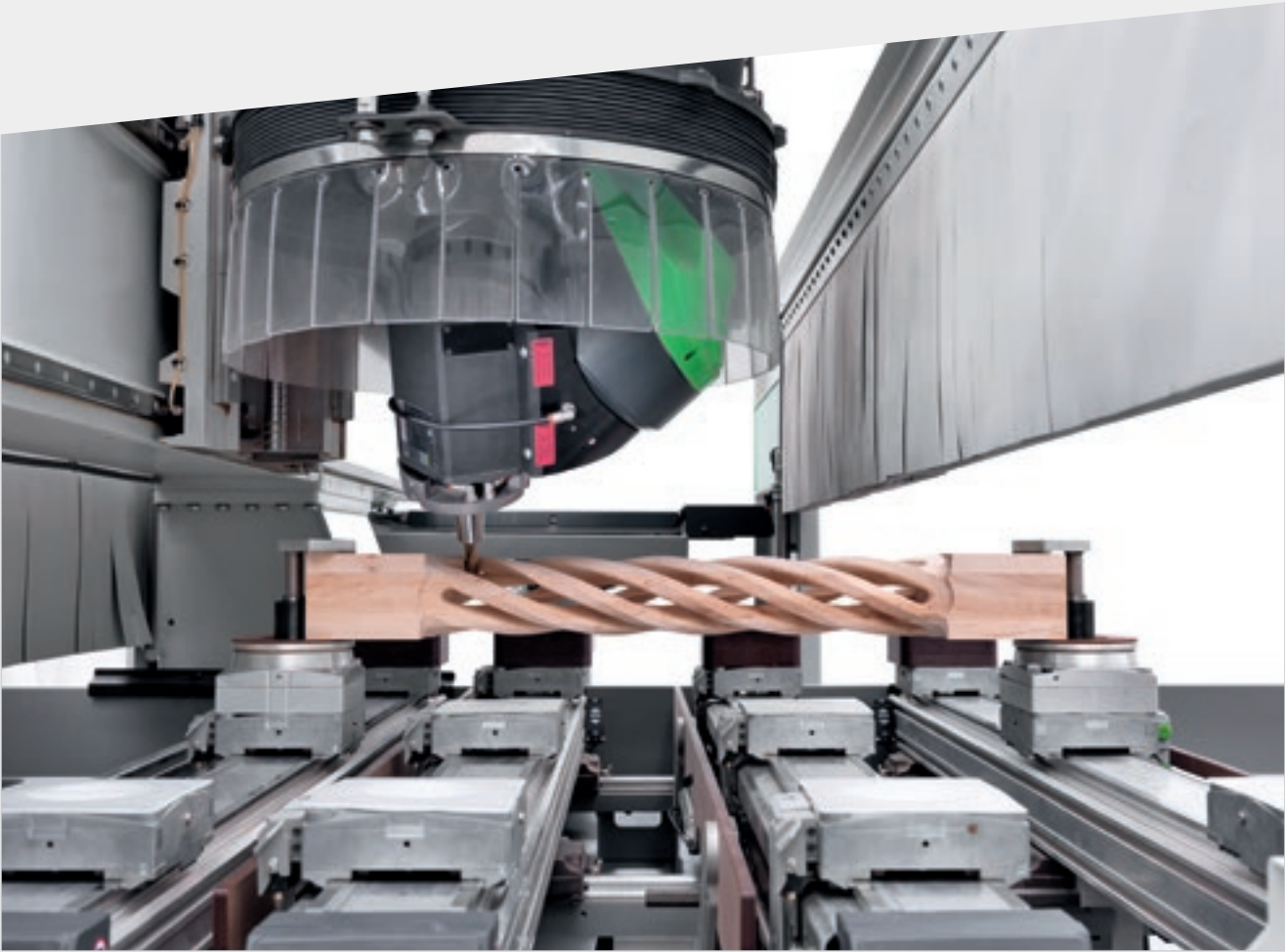

Adjustable suction hood up to 12 settings.

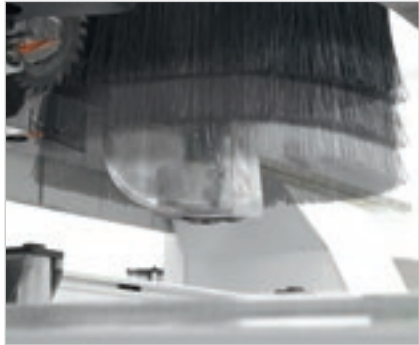

NC-controlled deflector (chip conveyor).



Chip collection basin supplied with the chip mat.

THE MOST ADVANCED TECHNOLOGY CLOSE AT HAND

bTouch is an optional feature that can be purchased after purchase of the machine to enhance the functionality and the usage of the technology available.



bTouch is the new 21.5" touch screen which enables you to carry out all of the functions previously performed using the mouse and the keyboard, enhancing the direct interaction between the user and the device.

Perfectly integrated with the B_SUITE 3.0 interface (and with later versions) and optimised for touch, this solution is incredibly simple, and makes the best possible use of the Biesse software functions installed on the machine. The screen has a maximum resolution of 1920 x 1080 (Full HD) at 60 Hz.

Specifically, you can:

- ✔ Create any CAD programme (including parametric programmes), with layouts and machining operations
- ✔ Move, rotate and increase the size of objects (panel, NC machine, tool etc.) present within the CAD/CAM area
- ✔ Quickly and simply complete warehouse tooling, by dragging the tools into their designated places
- ✔ Prepare the machine for the correct positioning of the panel (machine set-up), moving tables and carriages into the desired position
- ✔ Send a programme machining list, change the parameters and send it to the NC machine for processing
- ✔ Manage all the controls present in soft-console

INDUSTRY 4.0 READY



Industry 4.0 is the new industry frontier, based on digital technologies and on machines that speak to companies. The products driving this revolution can communicate and interact independently within production processes, which in turn are connected via intelligent networks.

Biesse is dedicated to transforming the factories owned by our customers into real-time factories that are ready to provide digital manufacturing opportunities. Intelligent machines and software become indispensable tools that facilitate the daily work of those who machine wood and other materials on a daily basis.

LOADING AND UNLOADING SOLUTIONS

Synchro is a loading/unloading device that transforms the Rover machining centre into an automatic cell for producing a stack of panels autonomously (without the need for an operator):

- ▶ It eliminates the risk of damage in the case of heavy panels that need to be handled by 2 operators
- ▶ It's easy to use, because the machining centre program also contains the Synchro command instructions
- ▶ It has limited overall dimensions, and can be positioned to the left or right of the machining centre
- ▶ It comes with various configurations, depending on the size of the panels to be handled and the layout of the stacks.

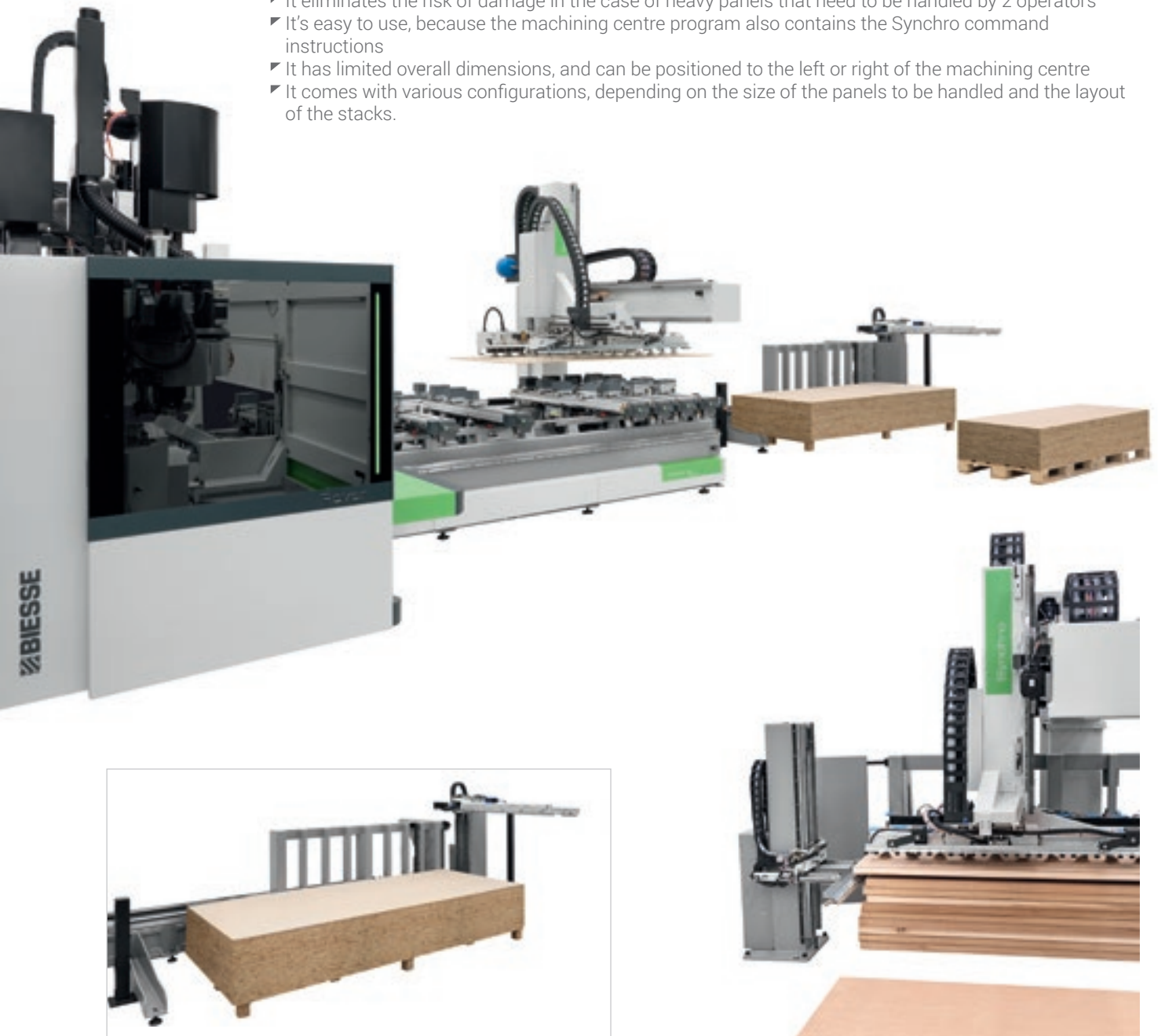

Mechanical detacher

Increases the reliability and repeatability of the automatic functioning cycle of the cell, compensating for the lack of alignment of the panels in the stack. It consists of a central or lateral mobile stop equipped with blowers to allow for the separation of the panels in the stack.

Automated cell for machining a batch of panels or doors.

Synchro can also machine stacks of different-sized panels, thanks to stack reference device and the panel pre-alignment cycle, which is performed while the machine is running, while the Rover machining centre processes the previous panel.

Panel pick-up device with automatic positioning of the suction cup holder rods

In accordance with the size of the panel to be picked up:

- No operator intervention is required to attach or remove the suction cup holder rods
- Idle time during format change operations is dramatically reduced
- The risk of collisions caused by incorrect tooling operations is reduced.
- Available in multi-zone mode with independent activation of the suction cups
- The suction cups can be configured with internal blowing to manage porous materials

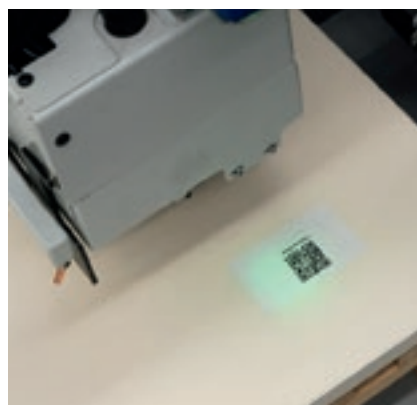
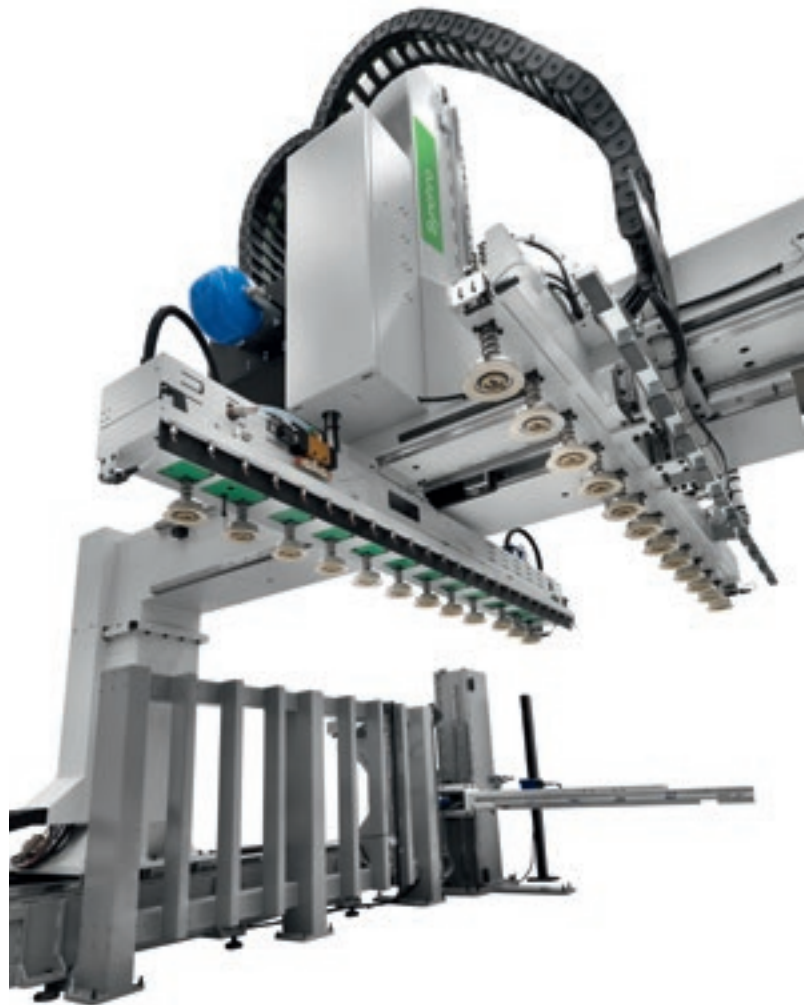

Two types of **bar code readers** are available for reading the bar codes on the top face and on the side face of the panel. These can be used to load the proper machining programme list avoiding operator error.

Dedicated configuration for the simultaneous loading/unloading of 2 panels, to maximise machining centre productivity:

- 0 operators
- 1 machining program
- 2 panels

WORKING UNIT CONFIGURATION

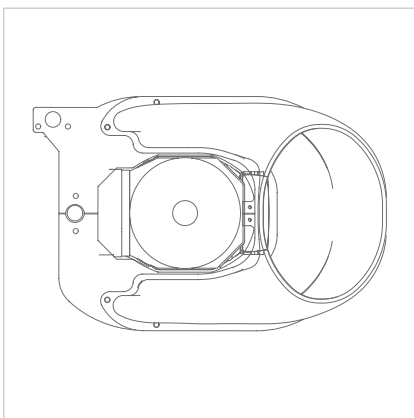

4-axis milling unit with air or liquid cooling and power levels up to 19.2 kW.

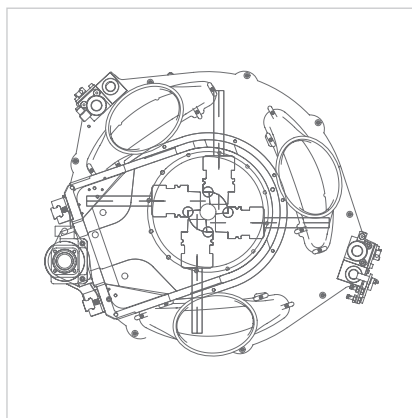

5-axis head with power up to 16.5 kW.

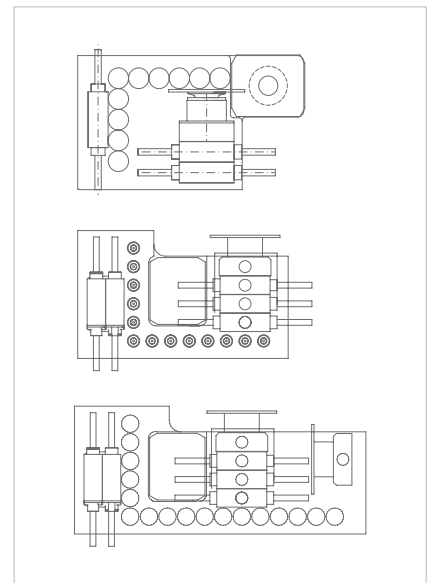

Available boring heads
BHZ 17 L - BHZ 24 L - BHZ 29 2L.

A COMPLETE RANGE OF AGGREGATES



TECHNICAL SPECIFICATIONS

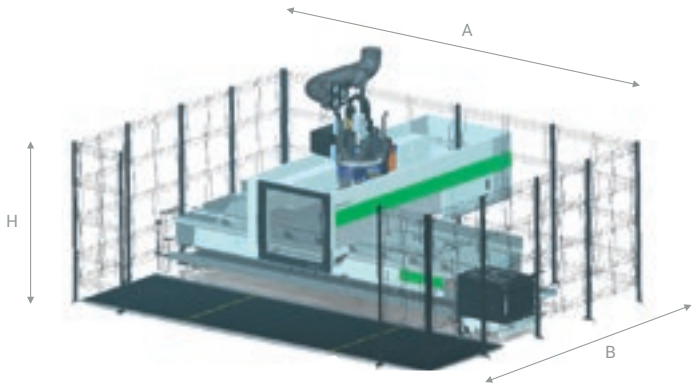

WORKING TABLE

		X	Y	Z
Rover A Smart 1632	mm/inch	3280/129	1620/64	245/9.6
Rover A Smart 1643	mm/inch	4320/170	1620/64	245/9.6
Rover A Smart 1659	mm/inch	5920/233	1620/64	245/9.6

FOOT PRINT

	Configuration	Available magazine		A	B	H
Rover A Smart 1632	1	12-place rack magazine	mm/inch	5600/220	4150/163	2770/109
	2	16-place Revolver tool magazine - 12-place rack magazine	mm/inch	5600/220	4610/181	2770/109
Rover A Smart 1643	2	16-place Revolver tool magazine - 12-place rack magazine	mm/inch	6630/261	4610/181	2770/109
Rover A Smart 1659	2	16-place Revolver tool magazine - 12-place rack magazine	mm/inch	8260/325	4610/181	2770/109

AXES SPEED

		H max
Axes speed X/Y/Z	m/foot/min	80 - 60 - 20 / 3 - 2.3 - 0.7
Vector speed	m/foot/min	100/3.9

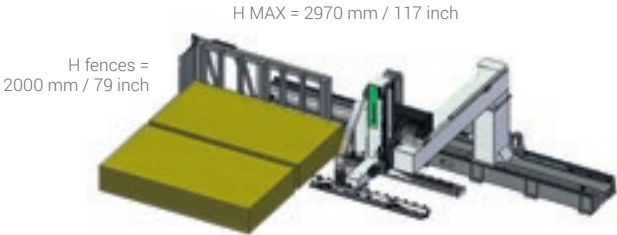

WORKING FIELDS SYNCHRO

Length (min/max)	mm/inch	400/3200 *- 16/ 126
Width (min/max)	mm/inch	200/2200 *- 8/87
Thickness (min/max)	mm/inch	8/150 - 0,3/6
Weight (1 panel/ 2 panels)	kg/lb	150/75 - 331/165
Useful height of stack	mm/inch	1000 - 39
Height of stack from ground (including 145 mm Europallet)	mm/inch	1145 - 45

(*) the Min and Max values may vary in accordance with the configurations of Synchro and the Rover machining centre to which Synchro is linked.

The technical specifications and drawings are non-binding. Some photos may show machines equipped with optional features. Biesse Spa reserves the right to carry out modifications without prior notice.

The correct noise pressure level, measured from the operator's workstation, is: LP = 78 dB (A), during boring. LP = 78.5 dB (A), during milling. The noise power level is: LWA = 93.5 dB, during boring. LWA = 95.5 dB, during milling. Uncertainty factor K = 4 dB.

The measurement was carried out in compliance with UNI EN ISO 3746, UNI EN ISO 11202, UNI EN 848-3 and subsequent modifications. The noise levels shown are emission levels and do not necessarily correspond to safe operation levels. Despite the fact that there is a relationship between emission and exposure levels, this may not be used in a reliable manner to establish whether further measures need to be taken. The factors determining the exposure level for the workforce include length of exposure, work environment characteristics, other sources of dust and noise, etc. i.e. the number of other adjoining machines and processes. At any rate, the above information will enable the operator to better evaluate dangers and risks.

HIGH-TECH BECOMES ACCESSIBLE AND INTUITIVE



B_SOLID IS A 3D CAD CAM SOFTWARE PROGRAM THAT SUPPORTS THE PERFORMANCE OF ANY MACHINING OPERATION THANKS TO VERTICAL MODULES DESIGNED FOR SPECIFIC MANUFACTURING PROCESSES.

- Planning in just a few clicks.
- Simulating machining operations to visualise the piece ahead of manufacturing and have some guidance for the planning phase.
- Virtual prototyping of the piece to avoid collisions and ensure optimal machine equipment.
- Machining operation simulation with a calculation of the execution time.



MANAGING PRODUCTION IN A SIMPLE, USER-FRIENDLY MANNER



SmartConnection is a web-based solution that can be used by any device.



SMARTCONNECTION IS A SOFTWARE PACKAGE FOR MANAGING JOB ORDERS WITHIN THE COMPANY - FROM THE GENERATION PHASE TO SCHEDULING AND ACTUAL PRODUCTION START-UP - IN JUST A FEW SIMPLE, INTUITIVE STEPS.

THANKS TO SMARTCONNECTION, THE PRODUCTION SITE MACHINES CAN BE LINKED UP TO TRANSFORM THE COMPANY INTO A 4.0 ENTITY.

MANAGE THE JOB ORDER



PLAN

SMART CONNECTION

Powered by Retuner



SCHEDULE

WORK

i Biesse is extending SmartConnection across all geographical areas.
To check availability in your country, get in touch with your commercial contact.

SOPHIA

GREATER VALUE FROM MACHINES

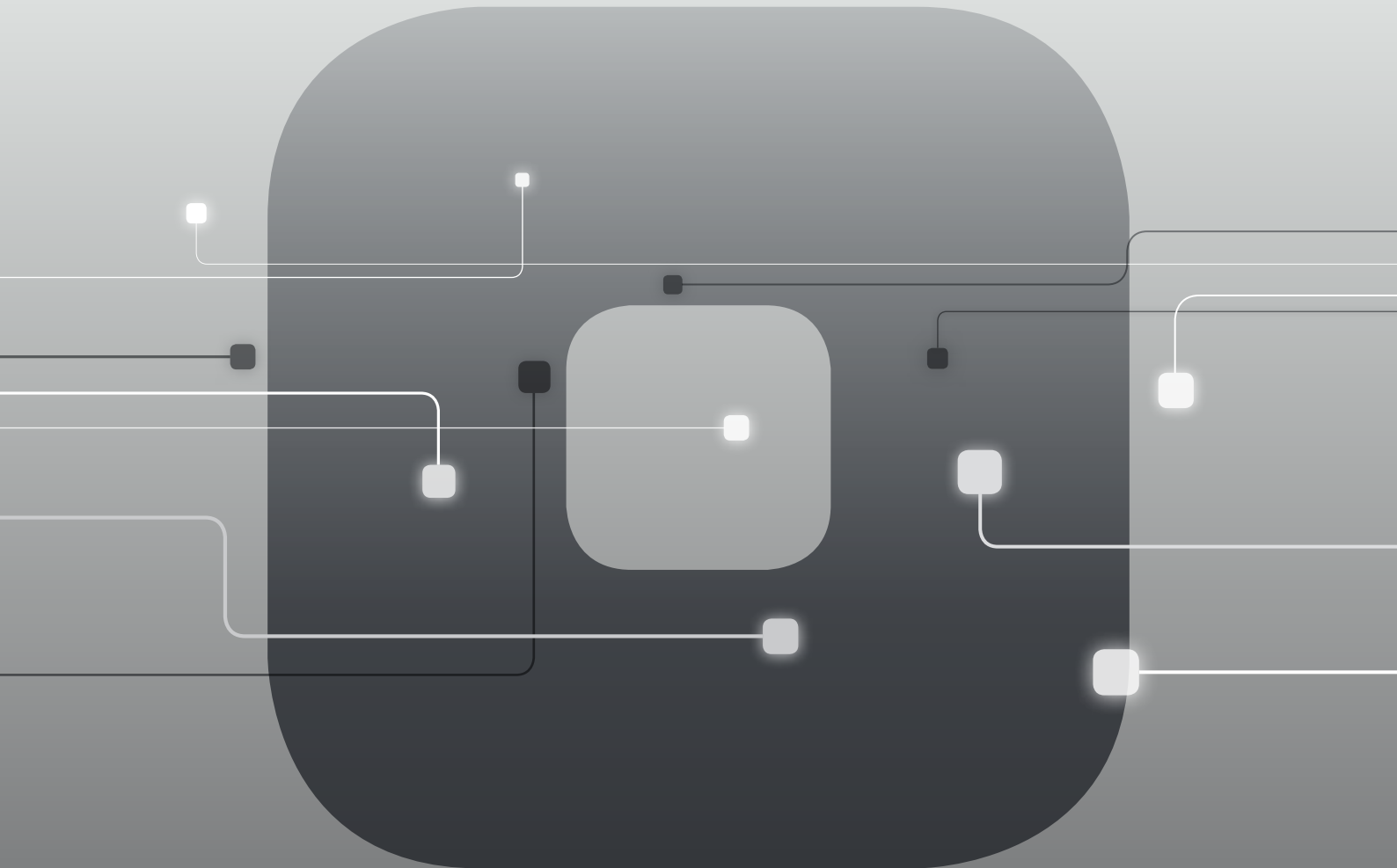

SOPHIA is the IoT platform created by Biesse in collaboration with Accenture which enables its customers to access a wide range of services to streamline and rationalise their work management processes.

It allows alerts and indicators to be sent to the customer in real time, in relation to production, the machines used and the type of process carried out. These are detailed instructions for more efficient use of the machine.

□ **10% CUT IN COSTS**

□ **50% REDUCTION
IN MACHINE DOWNTIME**

□ **10% INCREASE
IN PRODUCTIVITY**

□ **80% REDUCTION IN PROBLEM
DIAGNOSTICS TIME**

**SOPHIA TAKES THE INTERACTION BETWEEN
CUSTOMER AND SERVICE TO A HIGHER LEVEL.**

iOT
SOPHIA

IoT - SOPHIA provides a comprehensive overview of the specific machine performance features, with remote diagnostics, machine stoppage analysis and fault prevention. The service includes a continuous connection with the control centre, the option of calling for assistance from within the customer app (such calls are managed as priorities), and an inspection visit for diagnostic and performance testing within the warranty period. Through SOPHIA, the customer receives priority technical assistance.

PARTS
SOPHIA

PARTS SOPHIA is the easy new, user-friendly and personalised tool for ordering Biesse spare parts. The portal offers customers, dealers and branches the chance to navigate within a personalised account, consult the constantly updated documentation of the machines purchased, and create a spare parts purchase basket indicating the real time availability in the warehouse and the relative price list. In addition, the progress of the order can be monitored at all times.

 **Biesse**

CUSTOMER CARE IS WHO WE ARE

SERVICES is a new experience for our customers, to offer not just excellent technology but the added value of an increasingly direct connection with the company, the professionals who work there and the experience they embody.



ADVANCED DIAGNOSTICS

Digital channels for remote interaction online 24/7. Always ready to intervene on-site seven days a week.



A WORLDWIDE NETWORK

39 branch offices, over 300 certified agents, retailers in 120 countries, and spare parts warehouses in America, Europe and the Far East.



SPARE PARTS AVAILABLE IMMEDIATELY

Identification, shipping and delivery of spare parts for every need.



EVOLVED TRAINING OPPORTUNITIES

Lots of on-site, online and classroom training modules for personalised growth.



VALUABLE SERVICES

A wide range of services and software packages to help our customers achieve continuous improvements in performance.

AN EXCELLENT LEVEL OF SERVICE

+550

HIGHLY SPECIALISED
TECHNICIANS AROUND
THE WORLD, READY TO HELP
CUSTOMERS WITH EVERY
NEED

90%

OF MACHINE DOWN CASES
WITH RESPONSE TIME
UNDER 1 HOUR

+100

EXPERTS IN DIRECT
CONTACT THROUGH
REMOTE CONNECTIONS
AND TELESERVICE

92%

OF SPARE PARTS ORDERS
FOR MACHINE DOWNTIME
PROCESSED WITHIN 24
HOURS

+50.000

ITEMS IN STOCK IN THE
SPARE PARTS WAREHOUSES

+5.000

PREVENTIVE MAINTENANCE
VISITS

80%

OF SUPPORT REQUESTS
SOLVED ONLINE

96%

OF SPARE PARTS ORDERS
DELIVERED IN FULL ON TIME

88%

OF CASES SOLVED WITH
THE FIRST ON-SITE VISIT

MADE WITH BIESSE

BIESSE TECHNOLOGY PULLS DOUBLE-DUTY AT MCM

One of the secrets to cost-justifying an investment in flexible, labor-saving technology is finding ways to keep it busy.

MCM Inc. of Toronto has mastered that trick of the trade. To maximize the return on investment for some of its plethora of CNC machinery, the company has purchased equipment that can be used both to fabricate parts for its custom office and retail environment projects and to manufacture acoustical ceiling panels it produces for another company. Many of the machines pulling double duty on MCM's shop floor sport the Biesse logo. "For our company, this is a great combination because the CNC machining for the acoustical product is fairly simple; it's just a lot of holes," said Gregory Rybak, who founded MCM, short for Millworks Custom Manufacturing, in 2001. "But having this technology greatly helps us with all of the custom work, especially for very intricate shapes and profiles. The acoustical ceiling panels are helping fill up our capacity, which is why we can afford to have all of these machines. If it were just for custom work, we would never be able to buy all of them." MCM has so many Biesse machines that Ry-

bak said even he loses count. He then proceeded to rattle them off resulting in the following list of 11 Biesse machines: Rover C9 5-axis CNC machining center with a combination table; Rover A 5-axis CNC machining center with a combination table; Two Rover B7 flat table CNC nesting routers; Rover G5 flat table machining center; Rover S CNC machining center with a 4x8 flat table; Rover A 1536G CNC nested-base workcell; Skipper 100 drilling machine, winner of an IWF 2006 Challengers Award; Two Selco beam saws Stream edgebander.

Rybak prides MCM's ability to tackle custom retail and office projects most of its competitors can't. In addition to its wealth of woodworking technology, MCM has custom veneer layup capabilities, a 40,000-square-foot metal fabrication shop and a 140-foot-long flat line. Rybak prides MCM's ability to tackle custom retail and office projects most of its competitors can't. In addition to its wealth of woodworking technology, MCM has custom veneer layup capabilities, a 40,000-square-foot metal fabrication shop and a 140-foot-long flat line finishing system.

MCM's newest Biesse machine is a Rover S CNC flat table machining center. It is

mainly used in tandem with the Skipper to manufacture acoustical ceiling panels, but also gets pressed into service from time to time to fabricate parts for commercial and office projects.

The Rover S, which is also used to fabricate parts from plastic and non-ferrous metals, replaced the job performed by one of MCM's two Rover B CNC nesting routers. Both Rover B machines are now dedicated to custom products. The Rover C9, a five-axis router with a flat table, is another example of a machine doing production and custom work. "The C9 is a combination machine that we use for the acoustical product but get used more for three-dimensional parts. We recently used the C9 to cut a railing that went through three floors of an office". The railing was actually glued-up solid oak about 2-3/8 inch. The top of the railing for each landing had a fairly intricate spiral design. "The five-axis machines have the most downtime; we may only use them 20 percent of the time," Rybak said. "But without the five-axis capacity we wouldn't be able to do a lot of the parts, like the railings. While you pay a premium for it, for us it's worth it."

IT'S BEEN A GOOD MARRIAGE. BIESSE IS A WORLD-CLASS SUPPLIER AND HAS BEEN A GOOD COMPANY FOR US OVER THE YEARS IN TERMS OF SERVICE AND SUPPORT



Gregory Rybak
MCM Founder

MCM2001.CA



Founded in Italy,
international native.

We are an international company that manufactures integrated lines and machines to process wood, glass, stone, plastic and composite materials and what will come next.

Thanks to our rooted competence nurtured by an ever-growing worldwide network, we support your business evolution – empowering your imagination.

Master of materials, since 1969.

We simplify your
manufacturing
process to make
the potential of
any material
shine.



Join the
Biesse world.

[biesse.com](https://www.biesse.com)



