

Vertical boring machine Vertikalni vrtalni stroj

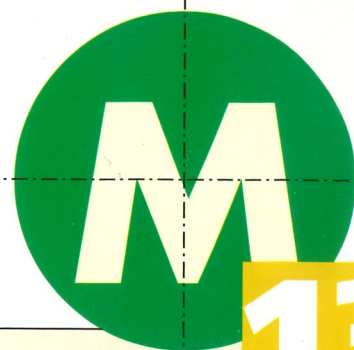

detel 

13

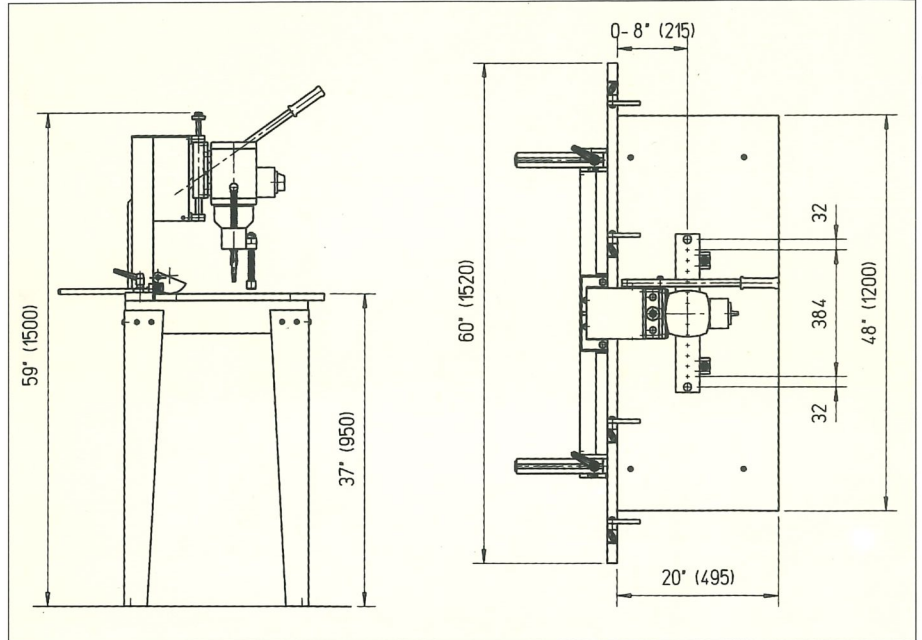
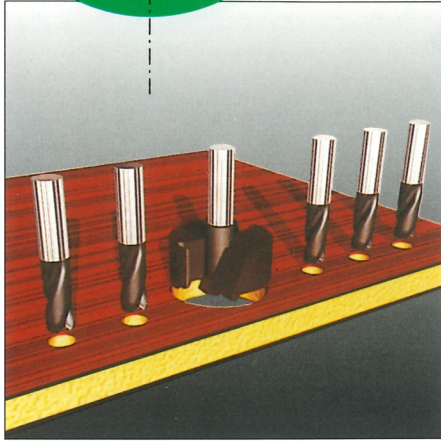
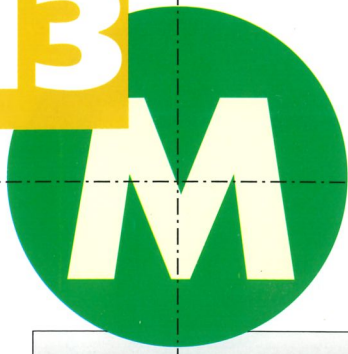

The machine is designed for manual vertical drilling (from top to bottom). The standard version has a drill chuck with 13 spindles (collet system M10, 30° / Ø 10 mm) and 32 mm axial distance. The machine is equipped with 2 manual index pins, 2 spring hold downs and 60° adjustable backfence with 4 stops. The equipment can be adjusted to meet customer's specification (different number of drilling spindles and axial distance, rotational drill chuck etc.)

Stroj je namenjen za ročno vertikalno vrtnje. Osnovna izvedba ima prigrájeno vrtno glavo s 13 vreteni in medosjem 32 mm. Stroj je opremljen 2 centrirnima konicama za vrstno vrtnje, z 2 vzmetnima vpenjaloma in prislonsko letvijo s 4 omejevalci. Na željo kupca lahko spremenimo določene tehnične karakteristike stroja (npr. medosna razdalja, število vreten, način vpetja svedrov, globino vrtnja, moč motorja itd.)

	USA	Europa		
Distance between the spindles	32 mm	32 mm	Medosna razdalja	32 mm
Number of drilling spindles	13	13	Število vreten	13
Max. drilling stroke	2"	50 mm	Maks. globina vrtnja	50 mm
Max. throat depth	8"	215 mm	Maks. odklik prislonske letve	215 mm
Supply voltage (single phase)	220V, 60Hz	220V, 50HZ	El. napetost (enofazni)	220V, 50Hz
			(trifazna)	380V, 50Hz
Motor power	1,1 kW	1,1 kW	Moč motorja	1,1 kW
Number of spindle rotations	3300 RPM	2800 RPM	Število vrtljajev	2800 Vrt./min
Net weight	240 pounds	110 kg	Neto teža	110 kg

Technical details and features are not binding. We reserve ourselves the possibility to proceed to all modifications. We should consider are appropriate.

Pridružujemo si pravico do tehničnih sprememb brez predhodnega obvestila.

