

**The New
Series PRISMATIC**

Giben®



Summary

Giben

Pag. 3 - 4 - 9

New Prismatic SP

Pag. 5 - 7 - 8

Saw carriage

Pag. 10 - 11

Pressure beam

Pag. 12 - 13

Side aligner

Pag. 14 - 15

Pusher

Pag. 16 - 21

New Prismatic SPT

pag. 17 - 18 - 19 - 20

Accessories

Pag. 22 - 23

Other Prismatic version

Pag. 24 - 25

G-Drive

Pag. 26 - 27 - 28 - 29

Optisave

Pag. 30

Technical specifications

Pag. 31



Giben®



GIBENdoBRASIL



GIBENDEUTSCHLAND



GIBENAMERICA



GIBENSCANDINAVIA



GIBENAUSTRALIA



GIBEN, specialisation brings advantages.

GIBEN, having focused its efforts totally on panel sizing, has accumulated an immense amount of knowledge on the subject. This has enabled the company to provide designs and solutions which anticipate customers needs rather than relating purely to current demands. Today GIBEN is a strong industrial group with four manufacturing plants and nine sales subsidiaries. Giben Impianti, Giben America, Giben Australia, Giben Canada, Giben do Brasil, Giben Deutschland, Giben de España, Giben France, Giben Scandinavia, Giben U.K. are proof of an important organisation, offering a guarantee to customers who trust in Giben's five decades of technological experience.

GIBEN acts as an ever present consultant, qualified to offer a universal service focused on the specific requirements of our customers.

TRAINING

Training on operating Giben machines: to achieve optimum performance in the shortest possible time.



**SPECIALIST
ADVICE**

From analysing the materials to be processed to evaluating complex parameters affected by financial and market conditions; Giben qualified personnel are able to advise and professionally support our customers.

QUALITY

All Giben machines are designed and built to offer maximum reliability and efficiency. To this effect Giben products undergo very demanding quality tests and conform to the strictest international safety standards.

The picture shows the "DELUXE ENCLOSURE" version of the PRISMATIC SP G-DRIVE 3D with advanced style air floatation table supports (optional).



New PRISMATIC SP panel sizing centres.

The SP version features front loading of the stacks and pusher with grippers. The grippers of the pusher equipped with double bottom floating appendices block the stack during the whole cutting cycle until the last trim cut is executed. Support tables under the pusher bar are equipped with roller modules to protect the board surface from any damage.



The picture shows the
PRISMATIC SP
G-DRIVE 2D
with fairing on pressure beam
(optional).



Over the last few years, **both image and look** gained strength even in the industry, which was formerly mastered by the functionality. Thanks to an inner cultural and methodological quality of its own design, GIBEN has developed an optimal product, which is reliable, safe, ergonomic and nice... and helps to work better.



SAW CARRIAGE and "triangle shaped" guiding system that has been in use for more than 30 years on all GIBEN machines, guaranteeing sturdiness and maximum stability.

PRISMATIC² H 100

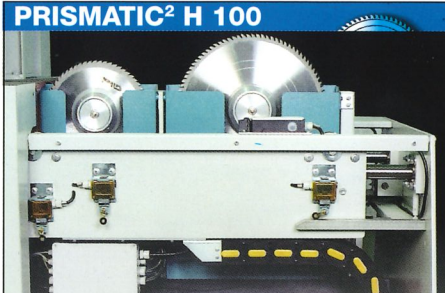

MAIN SAW BLADE PROJECTION	100 mm
MAIN SAW MOTOR	7,5 kW (11kW)
SAW CARRIAGE FEED SPEED	1-100 m/min.

PRISMATIC² H 115

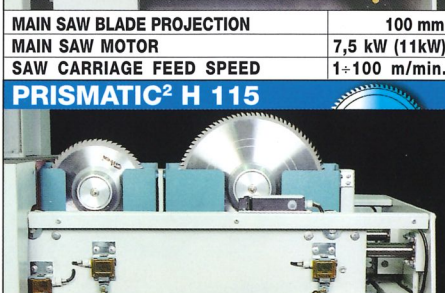

MAIN SAW BLADE PROJECTION	115 mm
MAIN SAW MOTOR	11 kW (13,2 kW)
SAW CARRIAGE FEED SPEED	1-130 m/min.

DURALUMINIUM SAW CARRIAGE

PRISMATIC 301



MAIN SAW BLADE PROJECTION	132
MAIN SAW MOTOR	15 kW (18 kW)
SAW CARRIAGE FEED SPEED	1-130 m/min.

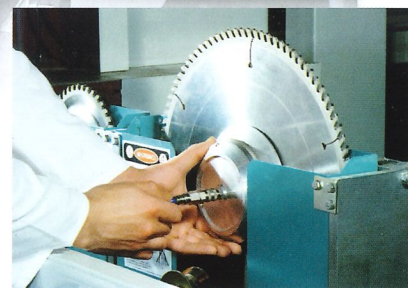
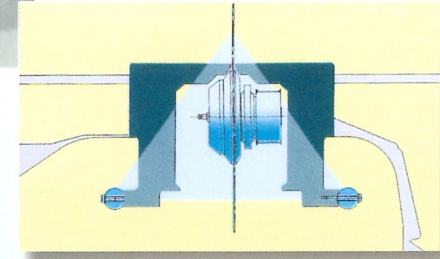
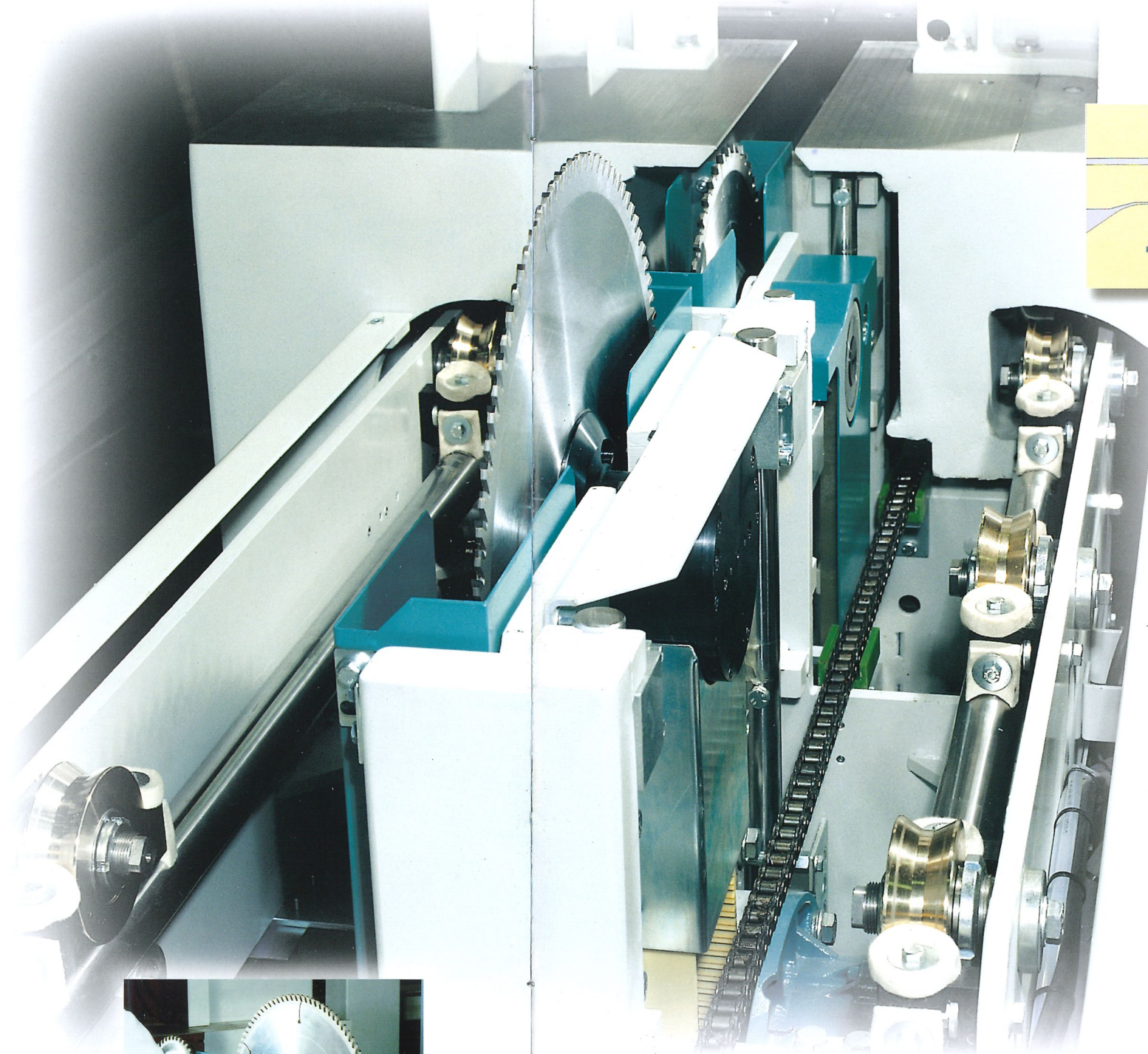

Quick pneumatic saw blade release.

Vibration free continuous stroke. The drive chain slides on a supporting guide to avoid any side deflection. A special system keeps the chain automatically tensioned.

Maximum rigidity.

Because of the symmetrical design of the carriage, the load on the main blade caused by cutting through the stack, is equally distributed between the two guide ways.

Maximum stability.

The centre of gravity of the saw carriage remains well below the two guide ways even under the load of the cutting cycle.

Minimum gap.

As the blade is positioned at the apex of an "ideal triangle" and all other elements of the carriage are at the base of this triangle, Giben models feature the smallest clearance between the two sides of the cutting line, thus improving rigidity of structure and accuracy of cut.

Toothed belts for main and scoring saw blades.

A toothed belt transmits the power from the motor with higher efficiency and avoids slipping; it does not require tensioning, has a longer life and is extremely easy to replace.

Automatic saw carriage stroke control relative to board size.

This avoids any unnecessary saw carriage movement and increases machine productivity. Saw carriage feed speed adjustment directly from the control panel.

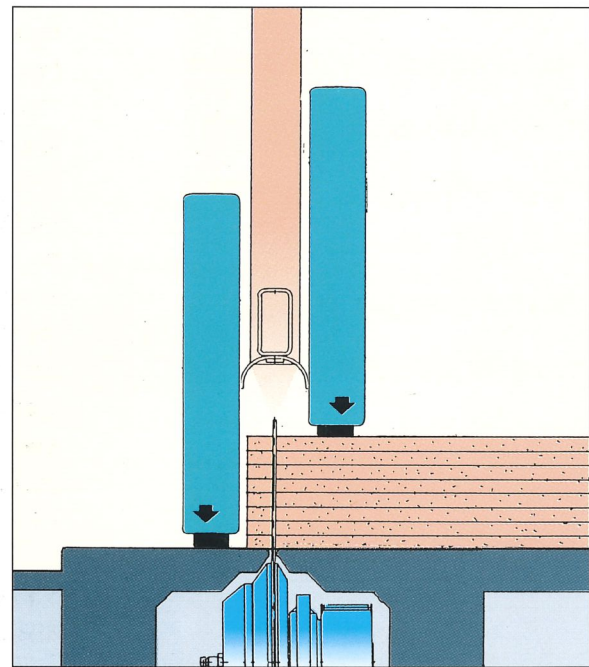
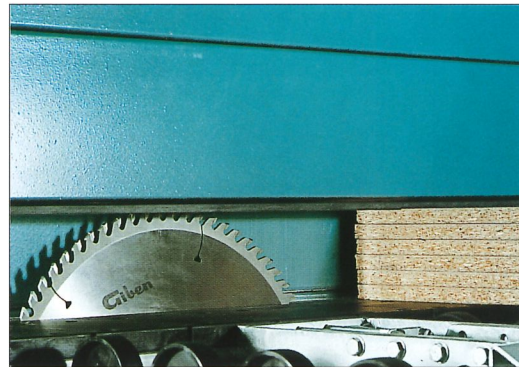

Minimum dust concentration level in the working area of the panel saw.

Split and independent PRESSURE BEAM. Besides blocking the stack and applying equal pressure even during the last trim cut, the beam guarantees optimum dust extraction.



The two pressure beams act separately on each side of the cutting line, exerting the correct pressure on the stack of boards.

A torsion bar running throughout each pressure beam ensures that both ends rise and lower in perfect alignment.

The entire stack is held firmly by pressure beam right up to the last trim cut.

The Giben system features the grippers opening only after the front pressure beam has lowered securely onto the stack of boards, while the rear pressure beam lowers only once the pusher has retracted.

The split structure of the pressure beam is particularly effective with very narrow trim cuts: whilst one side of the pressure beam keeps the stack firmly in position, the other locks tightly onto the working table facilitating efficient dust extraction and avoiding scattering of offcuts.

A side aligner with one retracting rubber roller

coated roller is fitted on a separate guide at the rear side of pressure beam. To avoid movement of the panels the aligning roller rises diagonally rather than vertically.

Down time is eliminated during the aligning operation.

The roller system provides constant alignment hence the pusher does not have to stop at each cut for realignment.

There is no mechanical limit to the minimum size of the trim cut

since the grippers can actually travel beyond the cutting line with their pushing points stopping right at the cutting line.

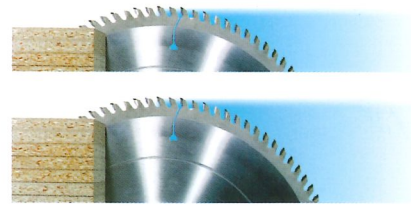

Electronic saw blade adjustment according to the stack height.

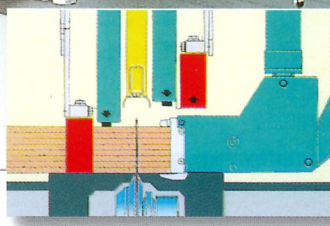
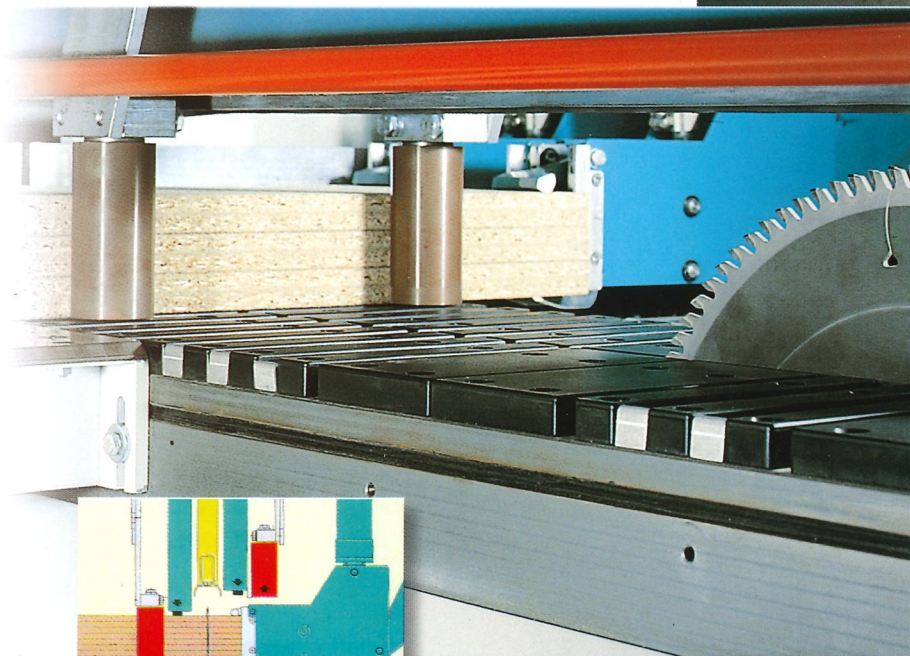

On request, a side aligner with two independent retracting rubber coated rollers fitted on a separate guide above the pressure beam.

Automatic side aligning. This device keeps the stack of strips constantly aligned during the forward and reverse movement of the pusher and during the whole cross cutting cycle until the last trim cut.

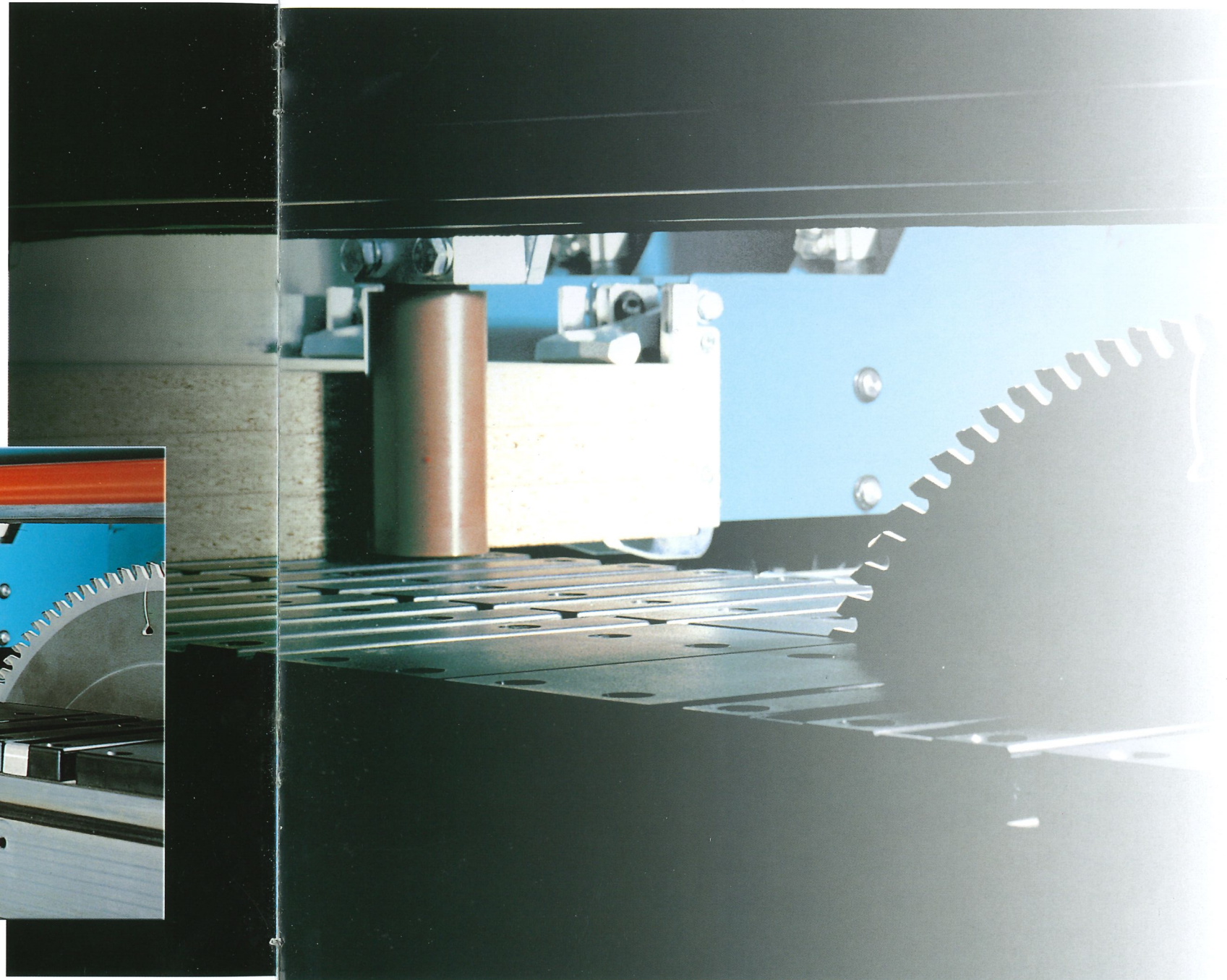

Side covers specially designed for noise reduction, allow easy access to all sections of the machine.

Perfect accuracy of the pusher.

The pusher carriage runs on two overhead side guides, in a parallel line relative to the saw carriage, driven by rack and pinion coupling. Two sets of racks are bolted on to the machined surfaces of the overhead side guides. Pinions are directly connected to, and moved by, equal gears. The pusher motor is positioned at an equal distance from the pinions, giving a perfectly balanced mechanism guaranteeing high accuracy and repeatability.

Fast transfer of the stack from the lift table.

With their bottom fingers retracted, the grippers pull the stack directly from the pile and transfer it to the support tables for front alignment. Only when alignment has been carried out do the grippers release the stack.

Blocking of the stack throughout the entire cutting cycle.

During the last cut, the grippers hold the stack firmly until the front split pressure beam reaches its lowest position. This helps to prevent even the slightest uncontrolled movement of the stack.

Optional lifting grippers to facilitate pusher movements over the following book.

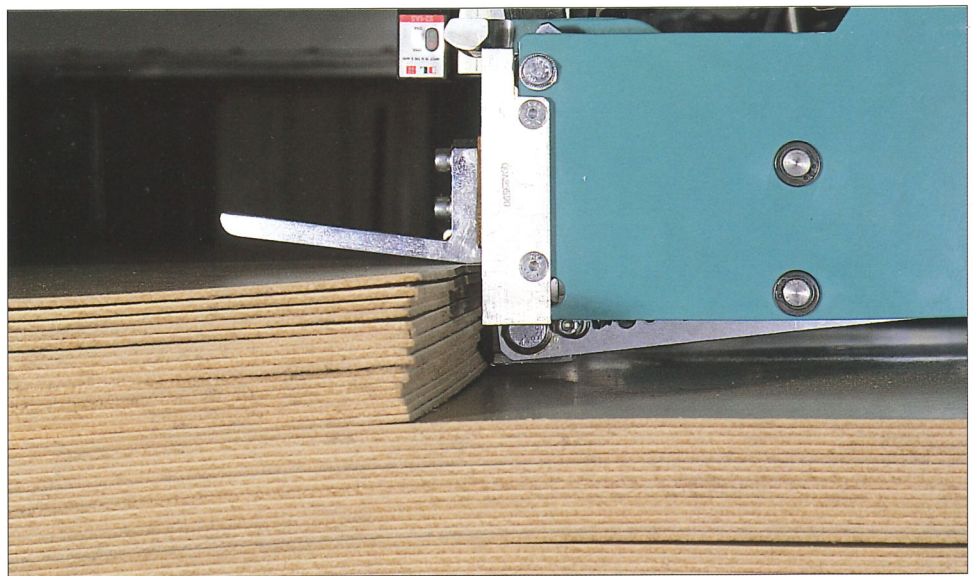
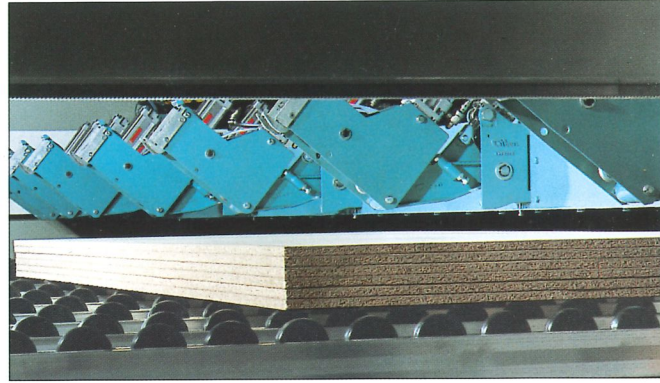

On request, a special device is available for automatic loading of thin and wavy material.

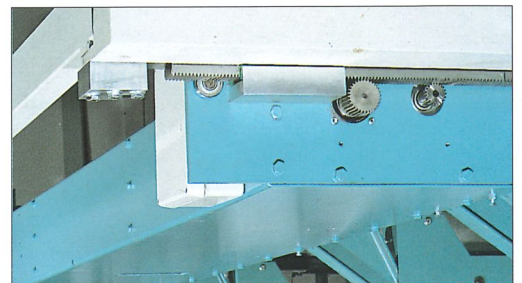

Accurate monitoring of pusher movements. A read out of the pusher positions is given by an encoder fitted on the pusher carriage.

The picture shows the **PRISMATIC SPT G-DRIVE** with fairing on pressure beam (optional).



New PRISMATIC SPT panel sizing centres.

The SPT model features automatic loading with lift table and pusher with grippers. This is the only machine on the market that assures a high speed cutting cycles thanks to special grippers, each equipped with two retracting bottom fingers that allow the stack to be collected from the lift table without the use of any special transfer equipment.



The picture shows the
"DELUXE ENCLOSURE"
version of the
PRISMATIC SPT
G-DRIVE 2D
with advanced style air floatation table
supports (optional).



Electronically controlled pusher with overhead side guides. The grippers on the pusher, fitted with two bottom retracting fingers, keep the stack firmly in place during the entire cutting cycle until the last trim cut.

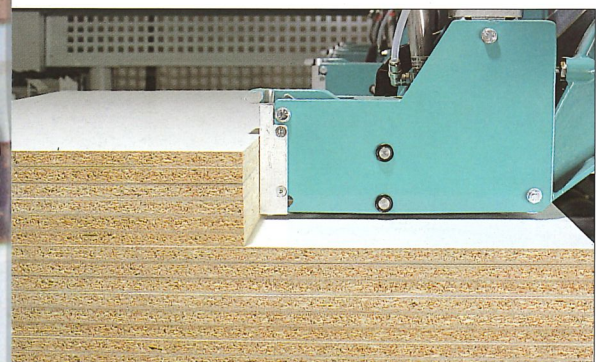
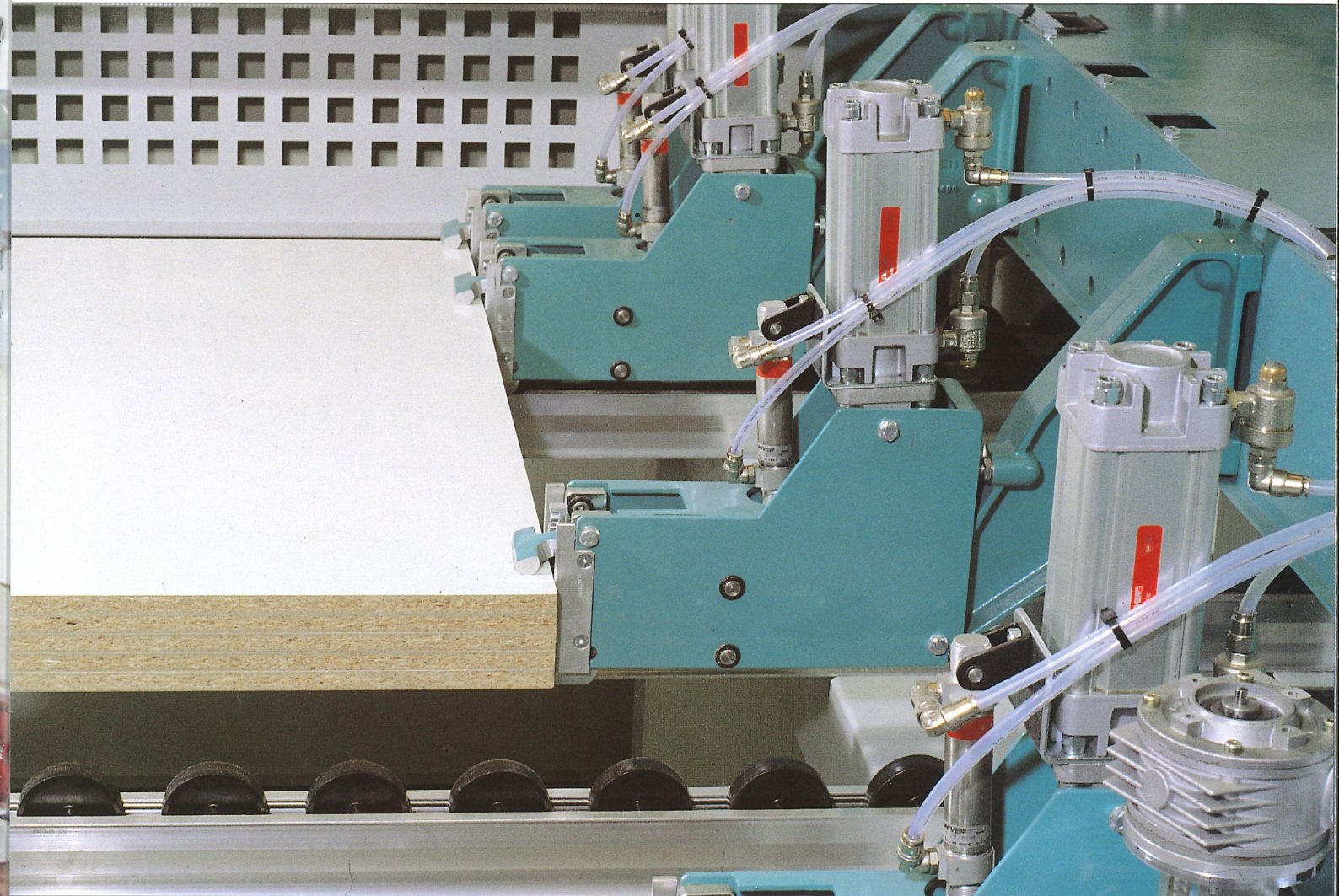

Optimised pusher movements relative to board size, avoiding unnecessary strokes and consequent down time.

The grippers for Prismatic SPT are fitted with a disappearing lower finger that allows quick infeed from the lift table without having to use additional.



Mitre fence.

Accessories for the new PRISMATIC range

GIBEN accessories are the key to a more personalized use of your beam saw by offering specific solutions to even the most diverse and demanding applications.



PF scorer on saw carriage

Jump scorer for the execution of chip free cuts of edge banded strips with square or rounded profiles (post and soft formed). A pre-cut of the profile is carried out during the cutting phase, significantly speeding up the cycle.

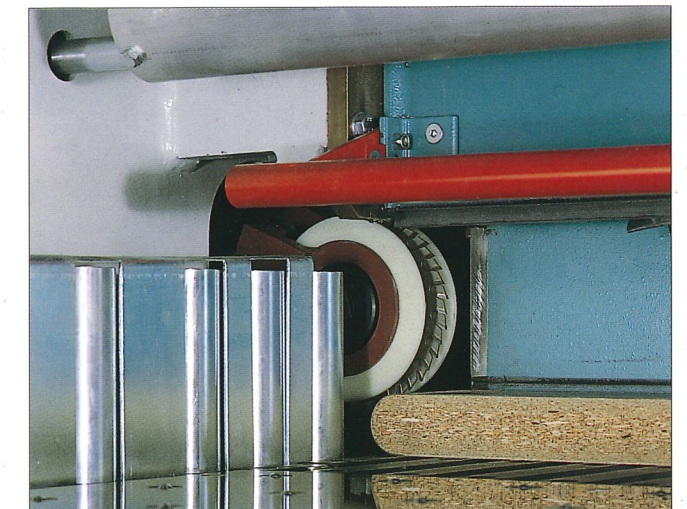

Attachment PF

Copying scorer for chip free cuts of edge banded strips with square or rounded edges (post and soft formed). This unit is fitted on the left hand side of the machine and driven by a pneumatic cylinder.

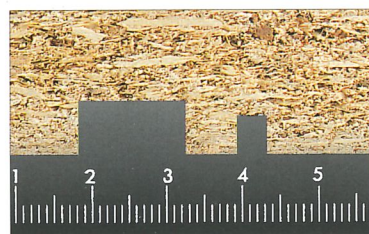

Groove cutting device with variable depths of cut programmed in automatic sequence.

Electrical adjustment of score. Horizontal and vertical adjustment are made while the blade is in operation with digital setting.

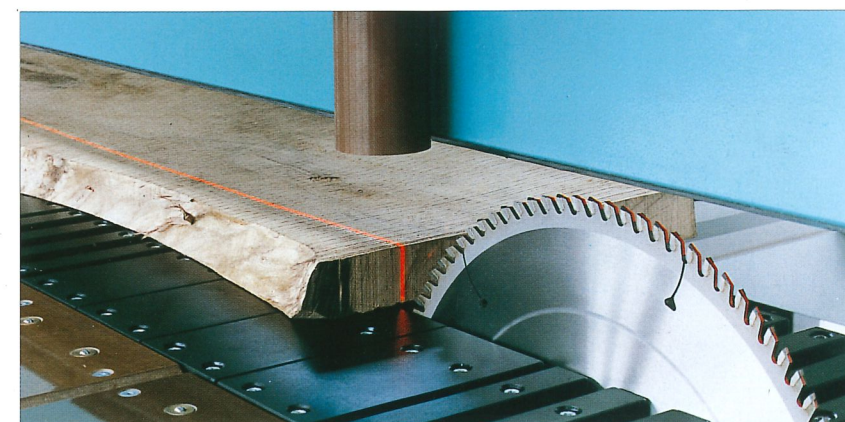
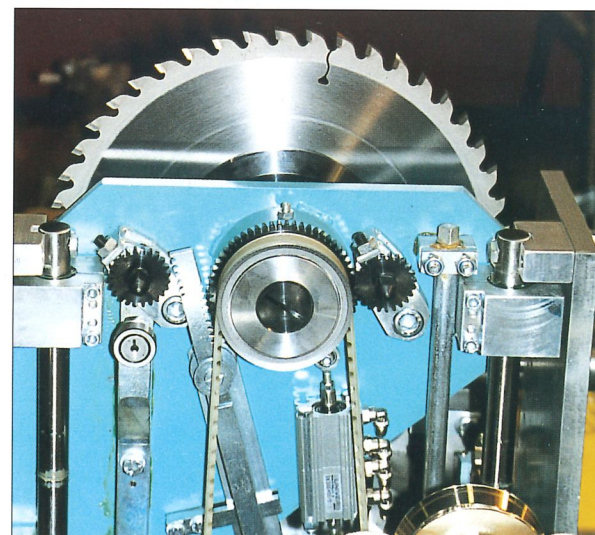

Laser light.

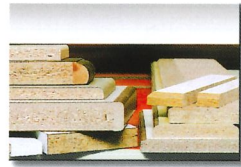

Model PF has been designed especially to size panels with soft or post formed edges or melamine coated profiles. This machine can either be used as a stand alone unit or be included in lines. In this latter case, model PF offers high productivity and flexibility according to each customer's requirements.

The picture shows the **PRISMATIC PF** in special "right hand" execution equipped with G-DRIVE, side loading device.

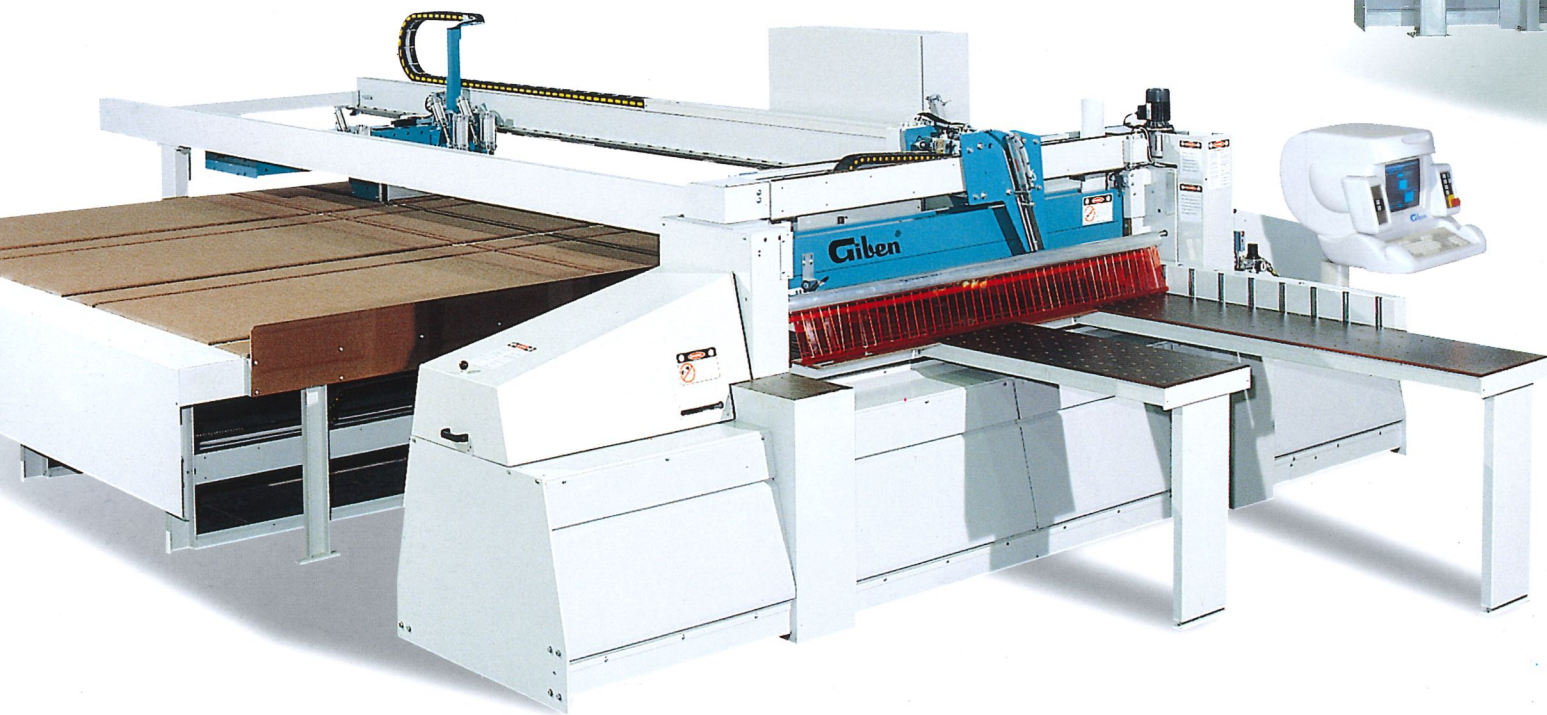

Models SP-SPT and PF previously described represent the most commonly internationally requested features. These machines, however, are available in several different configurations. Following the GIBEN tradition, **the Prismatic can be adapted to meet specific individual requirements.**

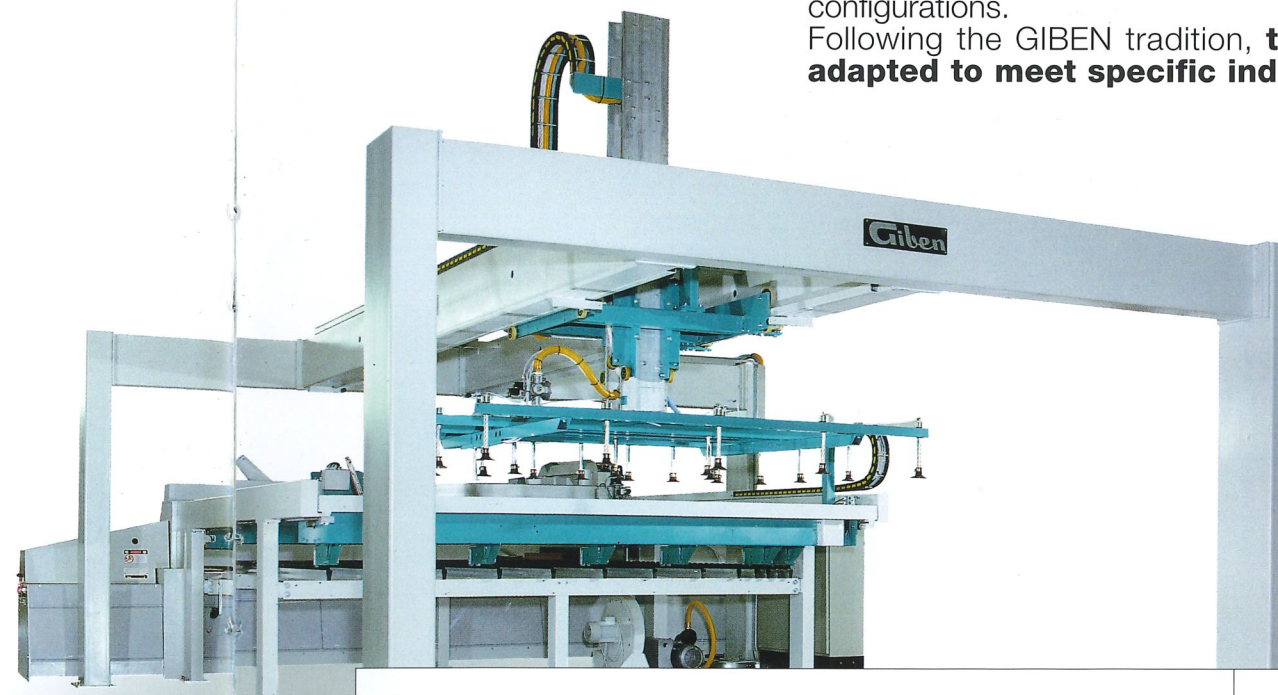

VACUUM. The drawing shows a Prismatic with a vacuum loading system, which helps to achieve a faster cycle. At the same time allows loading from piles of different thickness, colours, etc.

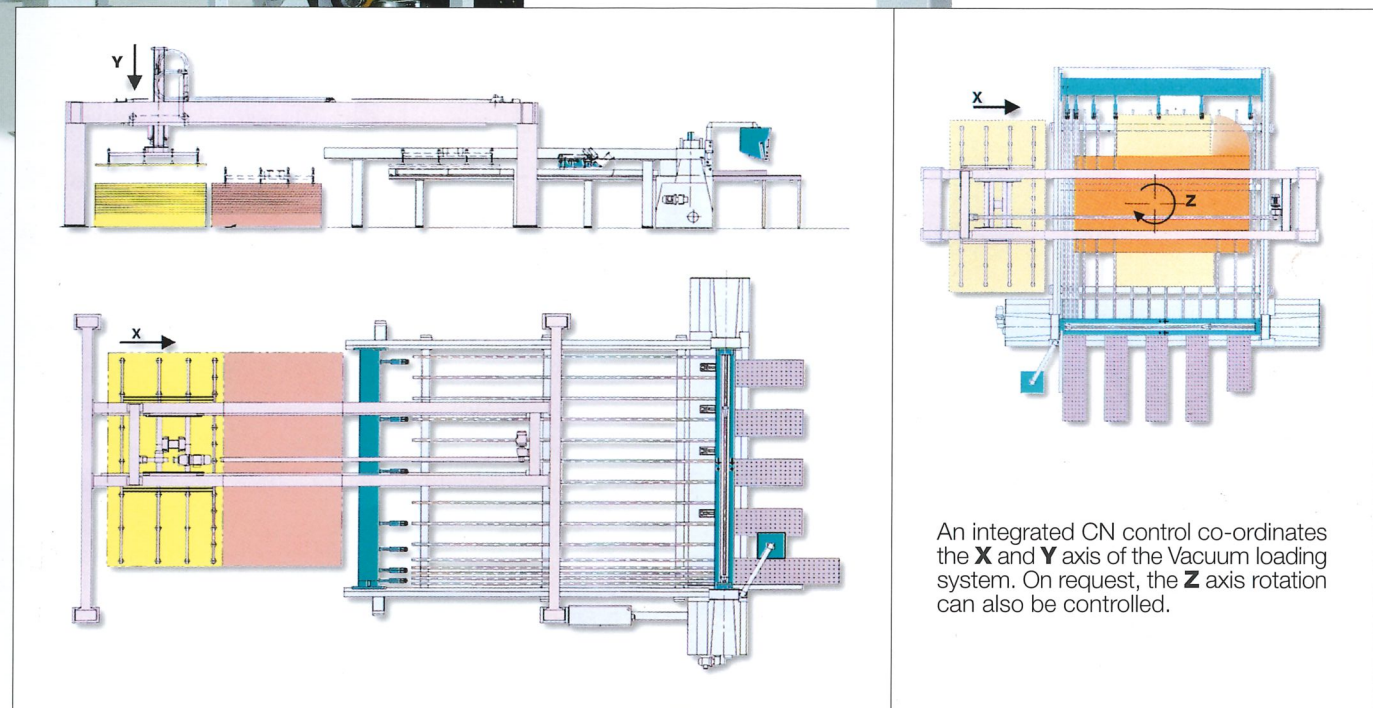

An integrated CN control co-ordinates the **X** and **Y** axis of the Vacuum loading system. On request, the **Z** axis rotation can also be controlled.

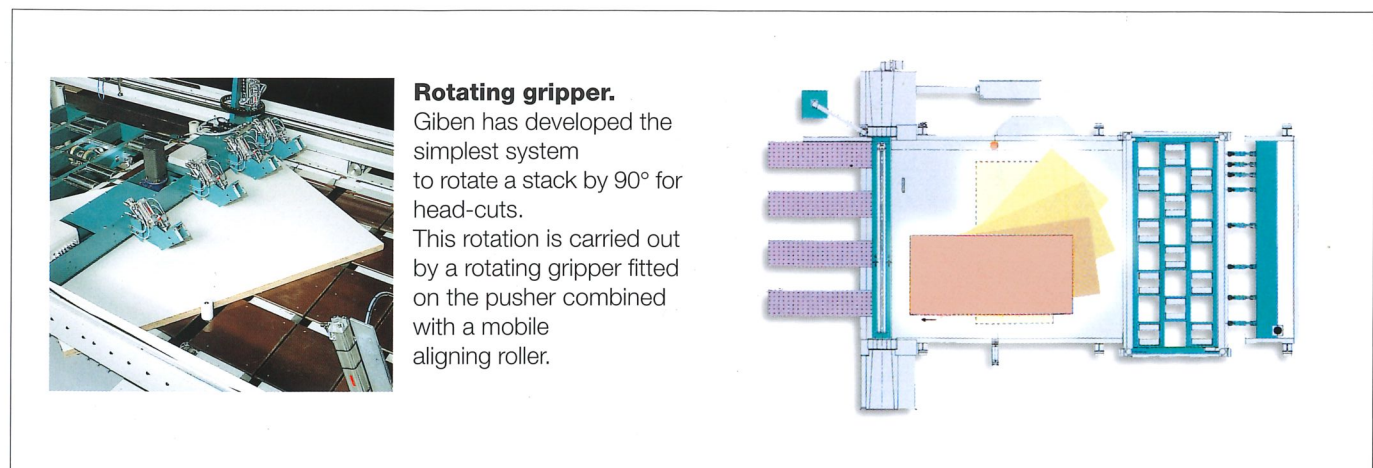
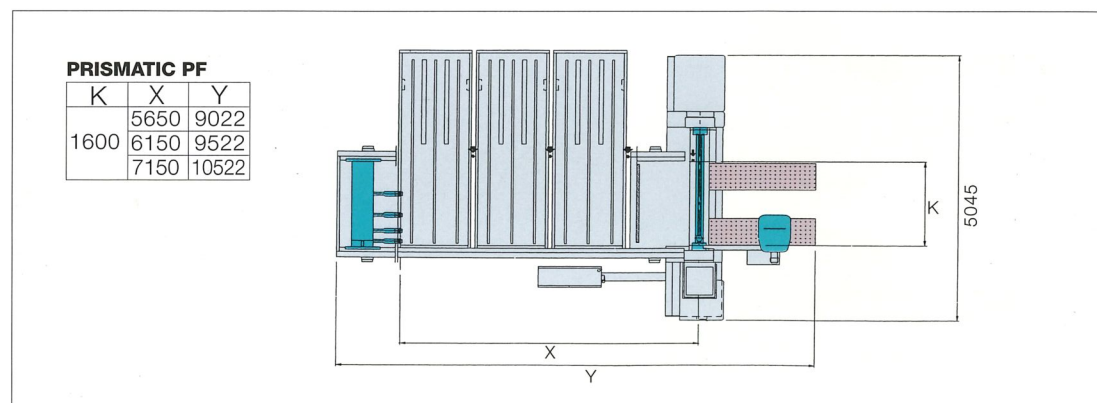

Rotating gripper. Giben has developed the simplest system to rotate a stack by 90° for head-cuts. This rotation is carried out by a rotating gripper fitted on the pusher combined with a mobile aligning roller.



The G-DRIVE control works within a multitasking environment using an industrial standard PC for programming cutting patterns and for control of the machine. G-DRIVE's innovative feature is that the PC is used not just as the operator's interface (for programming and displaying cutting patterns, alarm signals, diagnostics, etc.), but also a direct control in real time of all the complex machine functions, leaving the PLC as a simple executorial tool. Maximum automation; easy to programme; minimum cycle times; diagnostics; simulation; can be networked; colour monitor. Automatic on-line transmission of the cutting patterns (on request) using Giben's optimisation software, Optisave.

Easy access to the control panel. The control pad and the electronic programmer are positioned on a monitor on the left side of the machine. The monitor can rotate 180°.



Infrared remote control for cycle START/STOP.

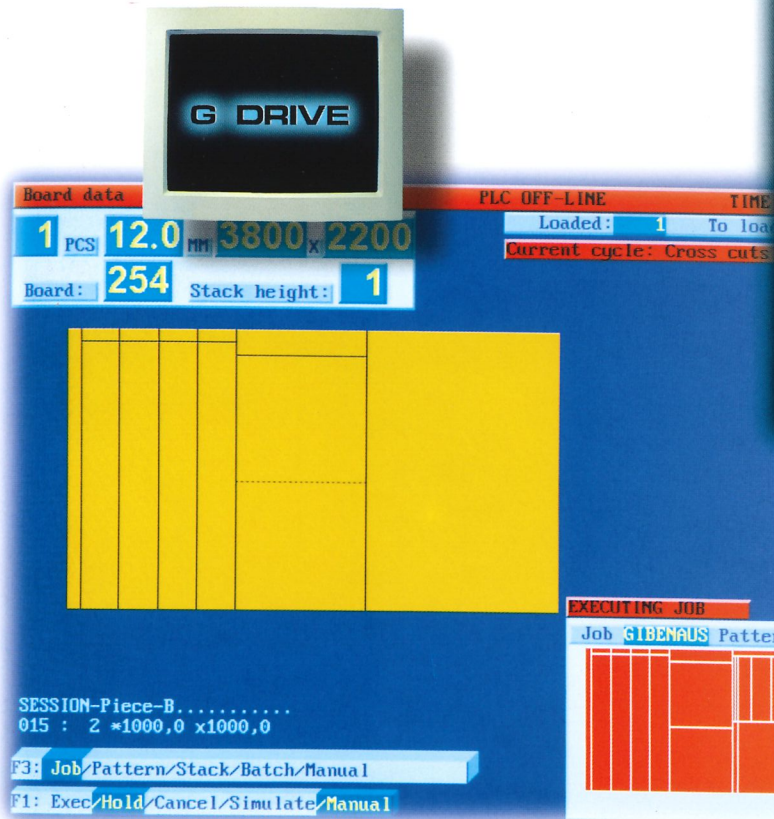
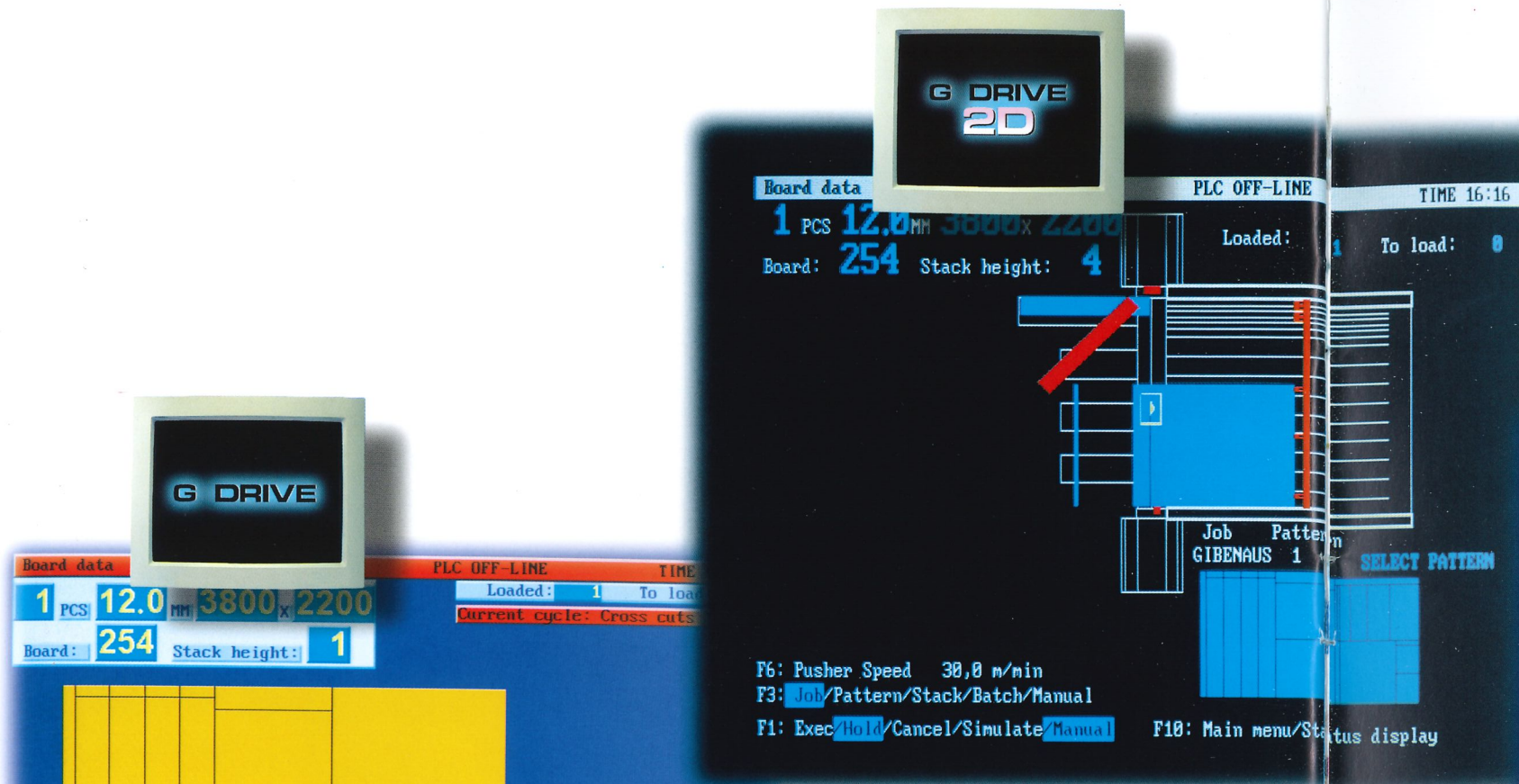

Software "R.T.G." with graphical display in scale of cutting patterns. During the cutting cycle it shows the parts being cut.

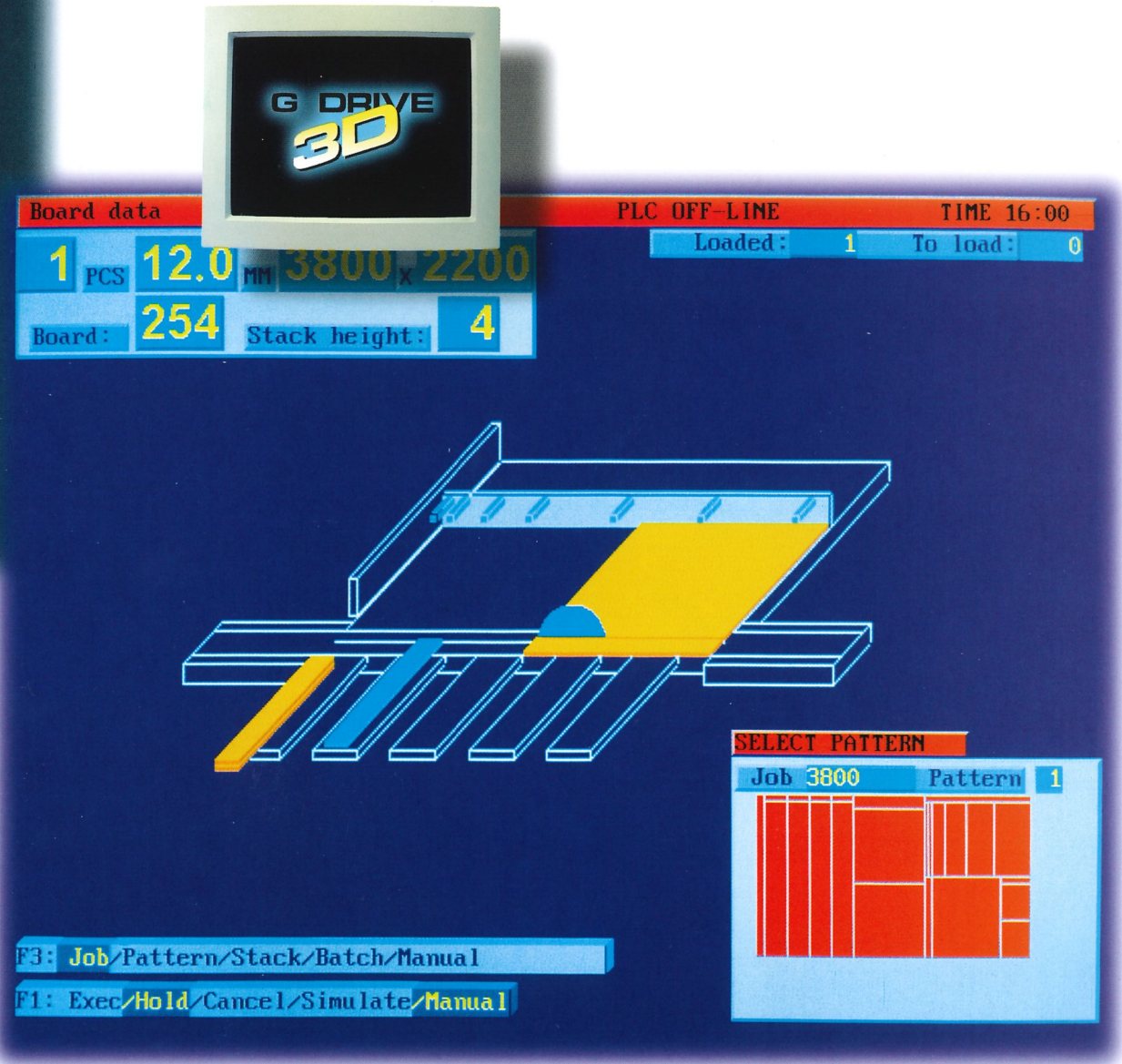
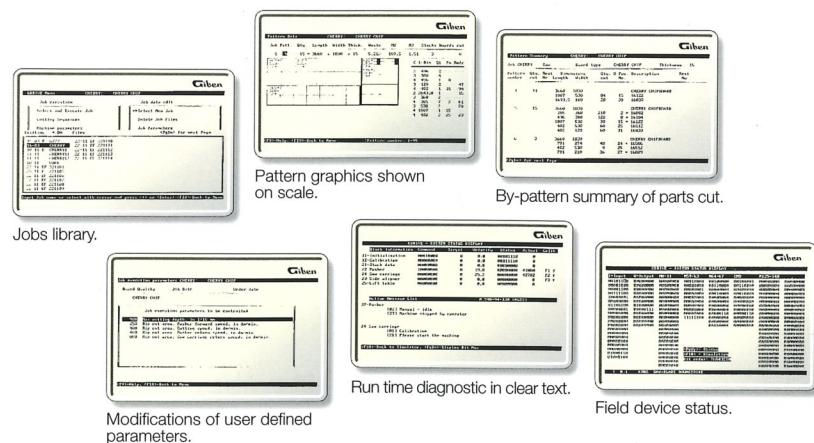

Software "R.T.G. 3 D" with tridimensional simulation of the machine cycles. The tridimensional layout of the machine and of the cutting pattern are displayed in scale. During the execution of the cutting cycle, the cutting operations and boards movements are simulated in real time.

OPTISAVE, Giben's optimisation software, is a perfect example of Giben's implementation of advanced technology. Optisave provides the best yield cutting patterns, taking into consideration the waste factor, the cost of running the saw, cutting time and the cost of the material being cut. Window menu - on-line connection with the main computer and the machine controller - can be networked - batch processing - label printing in processing order with a bar code - control rest parts of stock records - re-use of rest parts for optimisation - "door" and "strip" optimisation - downloading management - cost calculation.

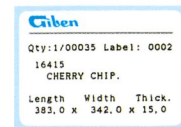
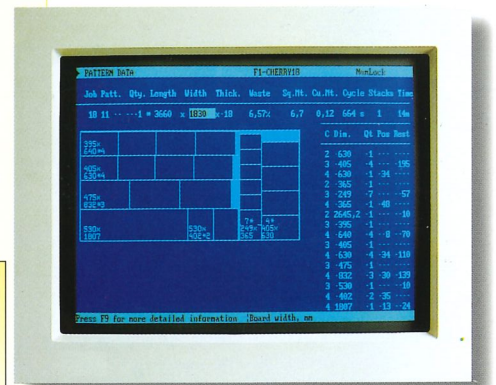
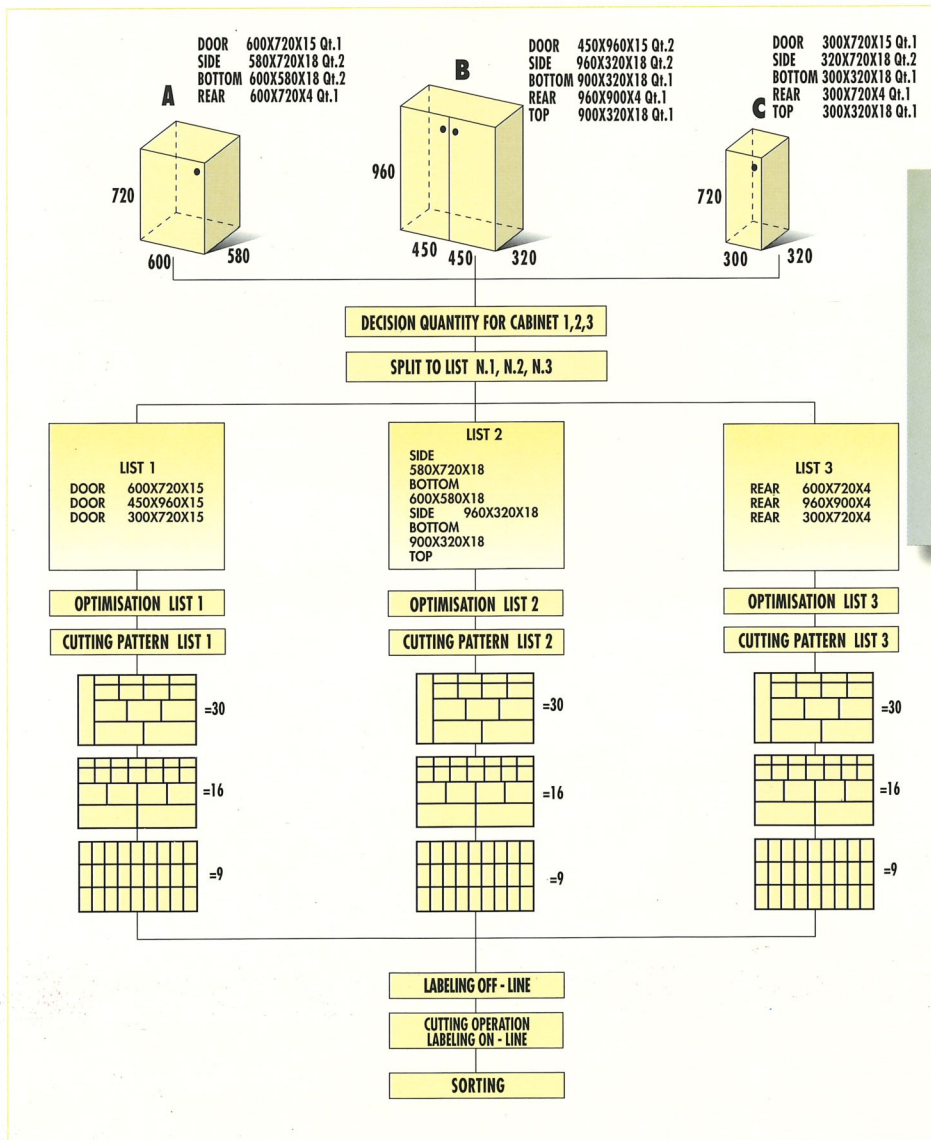
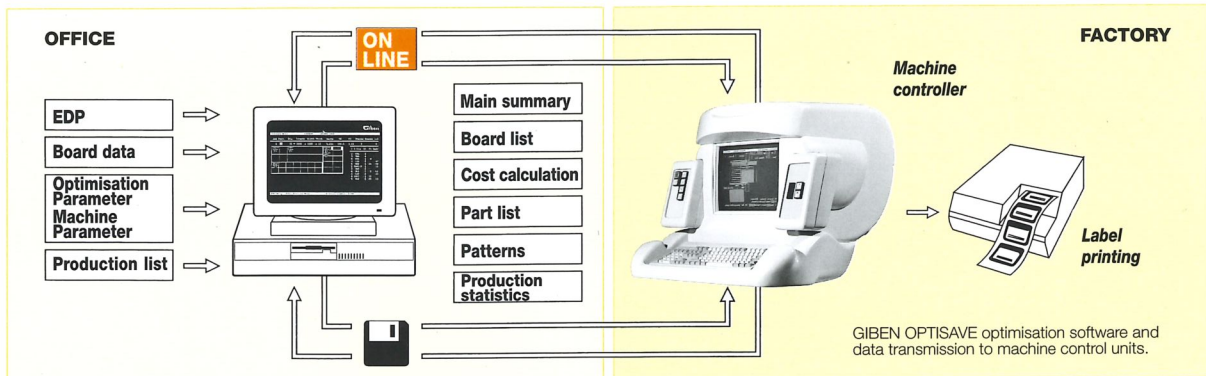

Optional on-line label printing.

PRISMATIC SP

K	X	Y
3300	3350	6720
3800	3350	6720
	4100	7420
4500	4100	7420
	4550	7920
5700	5800	9170

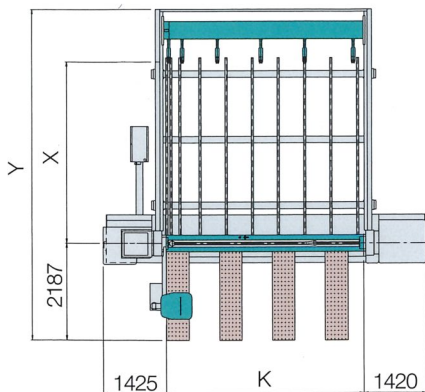

PRISMATIC SPT

K	X	Y
3300	1600	8170
3800	1600	8170
	2200	8690
4500	1600	8150
	2200	9470
5700	2200	10020
	2700	10550

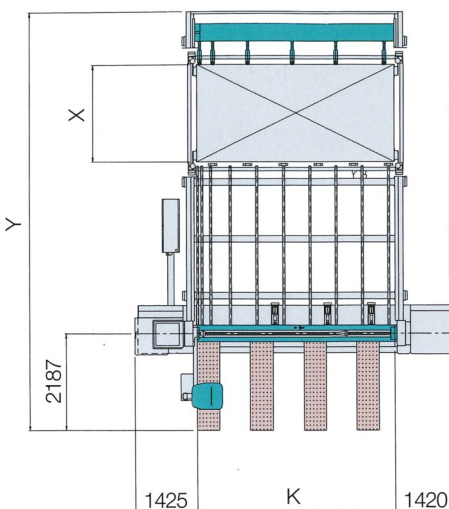

Technical specifications	PRISMATIC ² H100		PRISMATIC ² H115		PRISMATIC 301	
	Hz 50	Hz 60	Hz 50	Hz60	Hz 50	Hz60
Saw projection	100 mm	3,9"	115 mm	4,4"	132 mm	5,2"
Saw carriage <input type="checkbox"/> feed speed <input type="checkbox"/> return speed	1÷100 m/min. 100 m/min.	3÷328 ft/min. 328 ft/min.	1÷130 m/min. 130 m/min.	3÷427 ft/min. 427 ft/min.	1÷130 m/min. 130 m/min.	3÷427 ft/min. 427 ft/min.
Main saw <input type="checkbox"/> motor	Ø 400 mm. 7,5 - (11) kW	Ø 15,7" 9 - (13,2) kW	Ø 430 mm. 11 - (13,2) kW	Ø 17" 13,2 - (16) kW	Ø 470 mm. 15 - (18) kW	Ø 18,5" 18 - (22) kW
Scoring saw <input type="checkbox"/> motor	Ø 215 mm. 2,2 kW	Ø 8,4" 2,6 kW	Ø 215 mm. 2,2kW	Ø 8,4" 2,6 kW	Ø 215 mm. 2,2 kW	Ø 8,4" 2,6 kW
Pusher traverse <input type="checkbox"/> fast feed (*) <input type="checkbox"/> return (*)	1÷60 m/min. 60 m/min.	3÷197 ft/min. 197 ft/min.	1÷60 m/min. 60 m/min.	3÷197 ft/min. 197 ft/min.	1÷60/min. 60 m/min.	3÷197 ft/min. 197 ft/min.
Dust extraction <input type="checkbox"/> air speed <input type="checkbox"/> dust extraction outlets	30÷35 m/sec. Ø 200 mm Ø 115 mm	98÷115 ft/sec. Ø 7,8" Ø 4,5"	30÷35 m/sec. Ø 200 mm Ø 115 mm	98÷115 ft/sec. Ø 7,8" Ø 4,5"	30÷35 m/sec. Ø 200 mm Ø 115 mm	98÷115 ft/sec. Ø 7,8" Ø 4,5"
Compressed air <input type="checkbox"/> pressure <input type="checkbox"/> consumption	5÷6 bar 20÷30 l/min.	5÷6 bar 20÷30 l/min.	5÷6 bar 20÷30 l/min.	5÷6 bar 20÷30 l/min.	5÷6 bar 20÷30 l/min.	5÷6 bar 20÷30 l/min.

(*) The feed speed of the pusher can be modified. The value stated above corresponds to a parametric data set during running tests. The data may vary country by country in relation to safety requirements.

PRISMATIC is equipped with devices which ensure that European safety standards (CE mark) are respected completely. In order to meet European safety standards the machine must be supplied with safety guards or the advanced style "Deluxe Enclosure".



MACHINES AND TECHNICAL DATA MAY VARY COUNTRY BY COUNTRY IN RELATION TO SAFETY REQUIREMENTS.

WE RESERVE THE RIGHT TO MAKE MODIFICATIONS WITHOUT PRIOR NOTICE PROVIDED THE OVERALL CAPACITY AND VALUE OF THE EQUIPMENT REMAIN UNCHANGED.

Giben[®]
IN THE WORLD

GIBENAMERICA INC.
PANEL SIZING MACHINES AND SYSTEMS
NORCROSS, GA 30071 - USA
Ph. 770-448-9140 - Fax 770-448-9133

GIBENAUSTRALIA PTY.LTD
PANEL SAWS AND ANGULAR SYSTEMS
SOMERTON PARK SA 5044-AUSTRALIA
Ph. 08-8358-0011 - Fax 08-8358-0022

GIBENdoBRASIL
MAQUINAS E EQUIPAMENTOS LTDA.
CEP. 81450-080 CURITIBA - PR - BRASIL
Ph. 041-3471030 - Fax 041-3471121

GIBENCANADA INC.
PANEL SIZING MACHINES AND SYSTEMS
WEIR, QUÉBEC CANADA, J0T 2V0
Ph. 819-687-3234 - Fax 819-687-8466

GIBENDEUTSCHLAND GmbH.
MASCHINEN UND ANLAGEN
ZUM AUFTEILEN VON PLATTEN
D - 72186 EMPFINGEN
Ph. 07485-99803-0 - Fax 07485-99803-23

GIBENdeESPAÑA S.A.
MÁQUINAS E INSTALACIONES PARA SECCIONAR
08015 BARCELONA - ESPAÑA
Ph. 93-4237993 - Fax 93-4260469

GIBENSCANDINAVIA A.S.
INDUSTRIELLE LØSNINGER
DK-5260 ODENSE S - DENMARK
Ph. 0045-65-958262 - Fax 0045-65-959449

GIBEN U.K. LIMITED
PANEL SAWS AND ANGULAR SYSTEMS
NG7 2NN - NOTTINGHAM
Ph. 0115-986-2150 - Fax 0115-986-2159

HEAD OFFICE:

GIBEN INTERNATIONAL S.p.A.
PANEL SIZING CENTRES

40065 PIANORO - BOLOGNA - ITALIA
Ph. +39-0516516400 - Fax +39-0516516425
E-mail: info@giben.it

www.giben.com