

Processing centres BMB 800/900



A good "grip" on window production

Fit for the future, flexible for everyday life.

Much has changed in terms of producing windows and doors. New customer requirements, different materials, improved insulation — to continue to be able to meet all your production needs in the future, you need a partner who also continues to develop. At HOMAG, you can be sure that our machines are constantly being developed; not to mention, they already fulfil the requirements of tomorrow.





Contents

- 04 What makes HOMAG future-oriented?
20 years' experience
- 05 Why HOMAG?
- 06 Requirements for window construction
- 08 At a glance: the power**Profiler**
- 10 Gripping and clamping technology
- 14 Spindles, units, tool changers
- 18 Additional functions and options
- 22 Scalable performance
- 24 Software/control
- 26 HOMAG Group LifeCycleServices

What makes HOMAG future-oriented? Over 20 years of experience!

It is now impossible to imagine window production without CNC technology. For more than 20 years, HOMAG has developed CNC machines for window construction that have revolutionized window processing. Today, it is possible to complete the entire processing process in just a single step with maximum precision and outstanding quality. You will benefit from partially and fully automatic solutions, allowing the production of up to 100 window units per shift. And of course, HOMAG offers solutions for all components and designs, leaving no customer wish unfulfilled.

Solutions for window construction

BMB 800/900 powerProfiler

Processing centers for the automated window production of 15–50 windows per shift. Autonomous processing due to automated loading and removal of parts. Thanks to the additional console table, both curved and surface parts can also be processed. One machine for all components.



BMG 300

Moving gantry processing centers for the universal processing of windows, doors, stairs and furniture parts — ideal for users with a wide mixture of products.

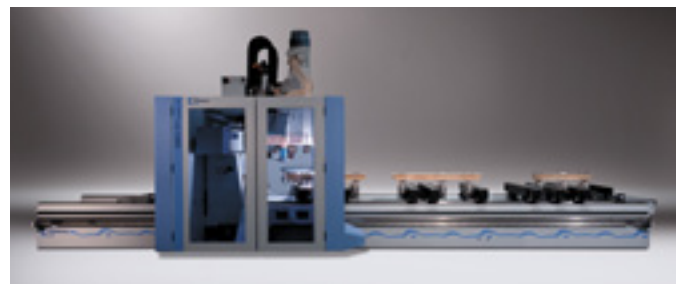

BMG 500

Moving gantry processing centers with heavy SORB TECH mineral compound machine bed. Extensive configuration possibilities so that windows, special elements and supplementary products can be produced at high levels of performance.



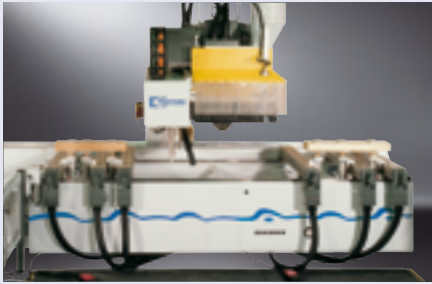

BOF 41

There from the very beginning: CNC processing center BOF 41 in cantilever design with clamping devices for scantlings and curved parts.

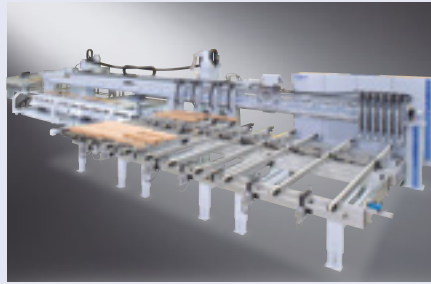

BOF 700 powerProfiler

The first generation of automated window production. With integrated snipping device, multiple parts can be processed in just one clamping procedure and curved and surface parts can be integrated.



BMB 900 powerProfiler

The second generation: everything in one machine, compact footprint, loading and unloading at one point and parallel processing on two clamping tables.

Why HOMAG?

Clamping systems for window production

Clamping systems specially optimized for window production, such as the 3-stage clamp with a large clamping height for precise, complete processing of window and door parts without subsequent rabbeting.



Tool changing system

Tool changers with high capacity and short change times are the basis for operational flexibility and high productivity.

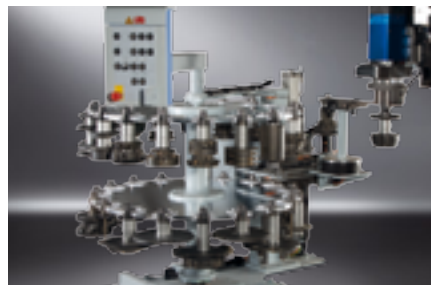

High-performance spindles and independent operation

High performance by means of simultaneous processing on both tables and liquid-cooled spindles with vector control.



A strong team

An efficient team for application engineering, system programming, startup and service for window production.



Expertise in the construction of CNC processing centers

Every year, we build over 2000 CNC processing centers worldwide.



Bespoke core components

The HOMAG Group develops and manufactures the core components for CNC technology itself.



We do not shy away from complex requirements — we find solutions.

Even products which at first glance do not appear to undergo any changes, may actually require several. This also changes the requirements put on the manufacturer. Whether it is windows with slim optics and thus new profile geometries that are popular, whether a greater variety of products requires an increased range of components, or new hardware and additional elements require further processing steps — you need machines that keep pace with this development. The products that you manufacture are also becoming more complex: whether dowels, pins or corner connections, whether fixtures, fans, openings, and cut-outs — you need to be prepared for every feature so that you can manufacture the precise windows that are required.

System diversity

Different climate zones, legal requirements and traditions are reflected in a vast variety of window systems worldwide. This poses no problem with HOMAG CNC technology and the experience of our window specialists.

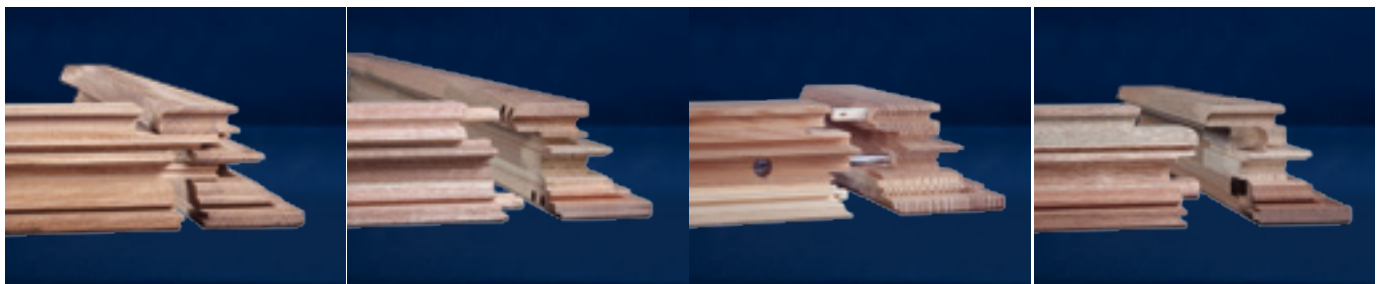
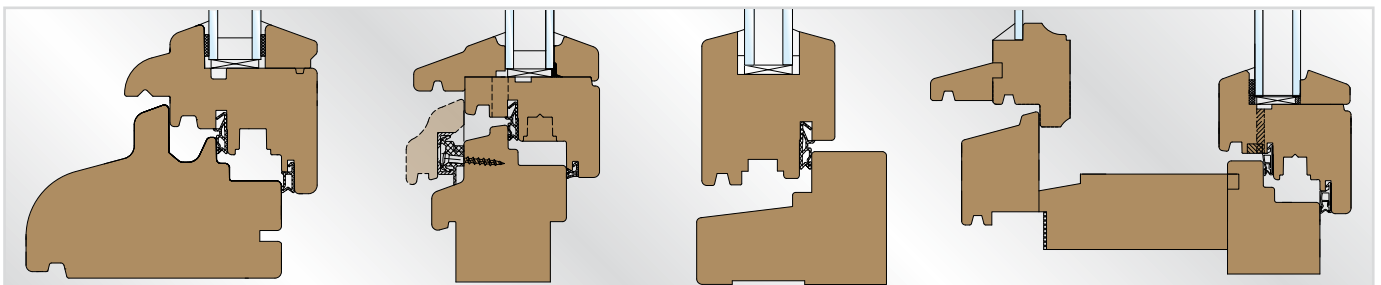

Corner connections

Slot and tenon, dowel, screw, rounded tenon... — which type of corner should it be? HOMAG CNC processing centers give you the choice and are prepared for future trends and developments.

“Slim fit” for windows.

Back to their origins: widths are becoming narrower again, cross-sections slimmer.

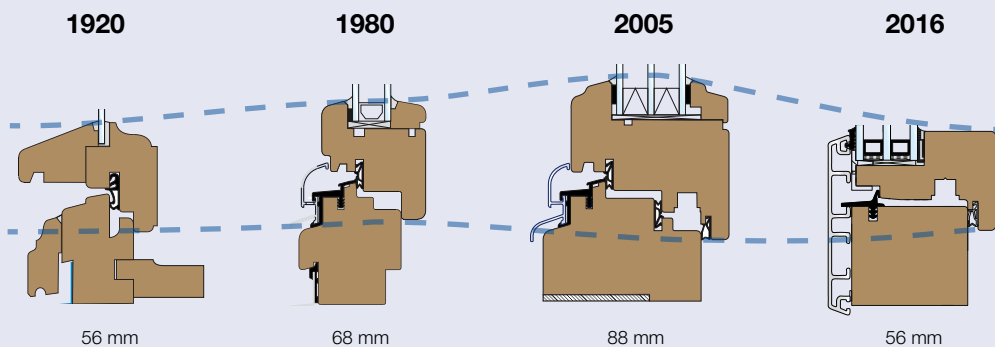

Product variety

More than just windows: The power**Profiler** even masters doors, conservatories, facades, plus lifting/sliding doors. One machine for everything.



Image sources: Menck Fenster GmbH, Steinbach Wintergarten KG and Nestlé Fenster GmbH.

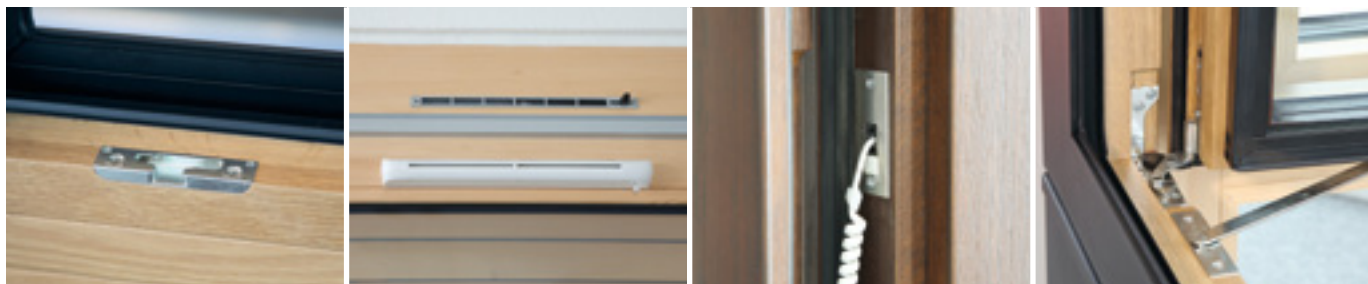

Complete processing

No additional operations: thanks to complete machining, CNC technology makes window production economical. Cut-outs and bore holes for recessed locking plates, concealed fixtures, screw marks, fan or cable guides are integrated in CNC precision. What more could you want?

At a glance: The powerProfiler BMB 800/900

1

A good "grip" on everything

The new gripping and clamping technology opens up new possibilities for profile design

⇒ **Future proof for new window systems**

2

High performance in a small space

Parallel processing of multiple components and fast tool change, loading and removal at one point

⇒ **Compact space, ergonomic operation, lower investment and operating costs**

3

All-in-one machine

Integration of all components: straight parts, curved parts, doors and supplementary elements

⇒ **One machine, one data interface, one tool set**

Console table

Additional consoles with stop pins for processing curves, doors and other surface parts.

Clamping table

Clamping table with program-controlled, movable, and rotatable clamping elements.

Tool changer

Large capacity for large and long tools, plus fast tool change thanks to the pre-changing system.





Basic machine

Solid gantry bridge, compact and rigid guide track for the clamping tables.

Gripping unit

Clamping, reclamping and returning the window scantlings. Precise workpiece handling thanks to the gripper system that pivots on both sides.

Infeed and outfeed table

Dual-level infeeds and outfeeds for centralized workpiece handling.

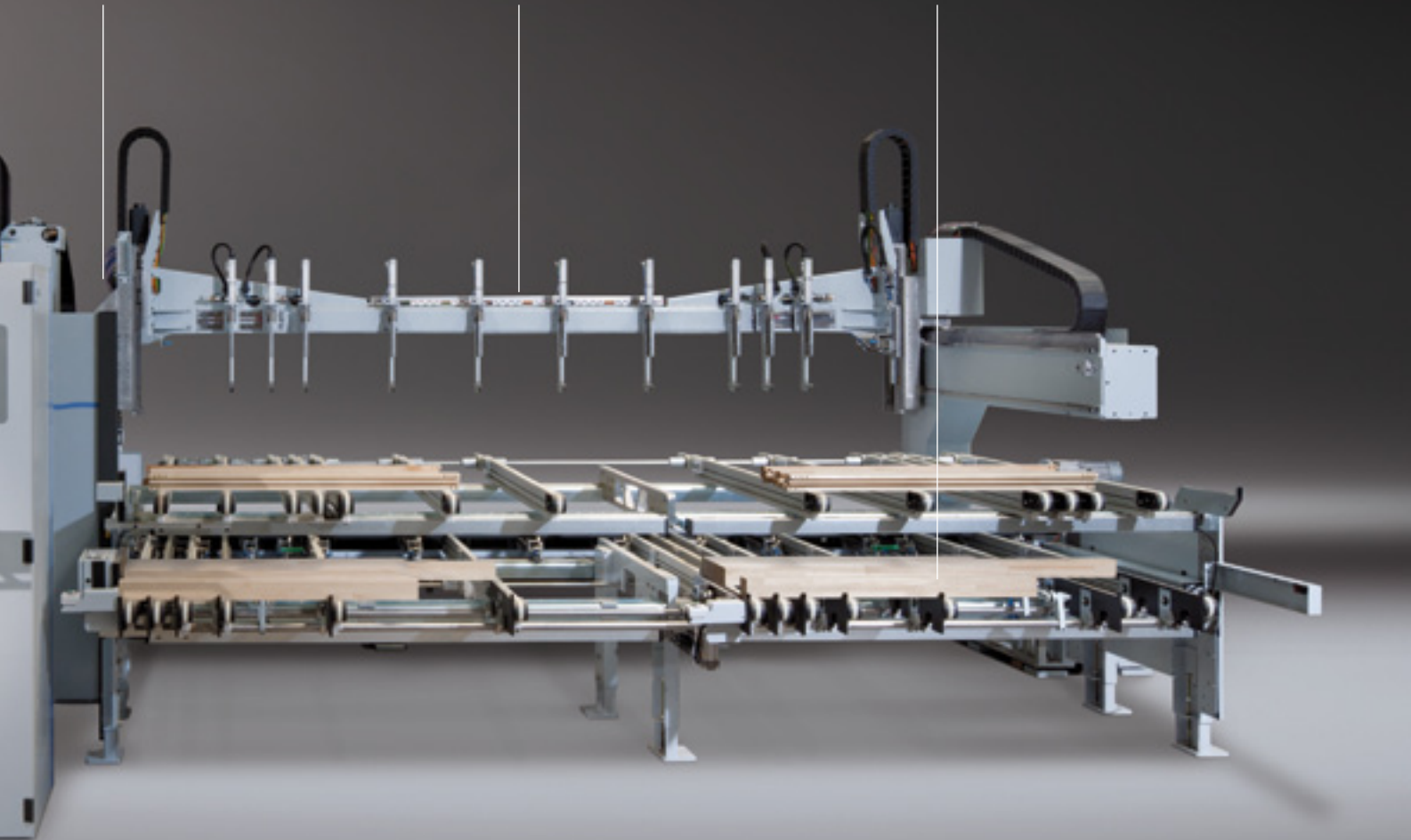

More options! BMB 800/900 powerProfiler clamping technology.

Our clamping technology – Your advantage. Flexible processing options and perfect processing results are guaranteed. Always the right position and the right overhang for processing through free clamping in all directions.





A perfect fit: Precise working thanks to the superior gripping and clamping technology.

It is critical that the workpieces are securely gripped during the entire manufacturing process. Therefore, HOMAG offers you a sophisticated gripping and clamping technology that features precise workpiece handling, great clamping depth and flexible processing options. Suitable for everything from XXS to XXL.

Free clamping

The gripping unit and clamping technology ensure maximum flexibility for processing. The components can be freely clamped in all directions, even while reclamping – freely selectable clamping depth, the clamp can be applied at a position of your choice, even in the rabbet.



From XXS to XXL

Components from a height of 20 to 150 mm, a width of 25 to 300 mm can be processed in automatic mode. Up to 4 200mm without, with reclamping 6 000 mm of length is possible in automatic mode.

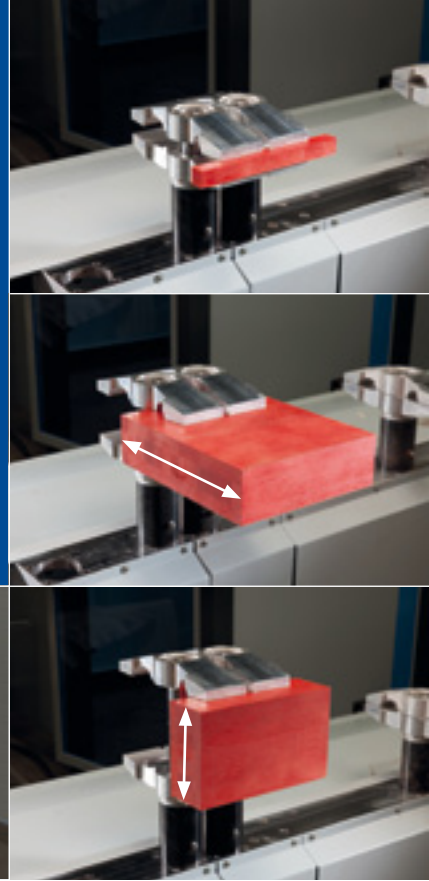

Dimensional check of unprocessed parts

During placing and clamping unprocessed parts, all the dimensions are checked for plausibility. This prevents the unprocessed parts from accidentally being positioned incorrectly.



Pivoting clamping plates

The clamping plates can be programmed to swing out to the side. This means that all bore holes and cut-outs can be processed regardless of the position of the clamping elements.



Integrated glass fixing rail

The gripping system also allows production of the glass fixing rail to be integrated. The trimmed rail is broken off and is placed on the outfeed belt. This ensures that all items which are supposed to be kept together actually do remain together.



Aligning the unprocessed parts

Pressure bolts align the unprocessed part with the insertion table and hold the part in place until the gripper unit picks up the unprocessed part.

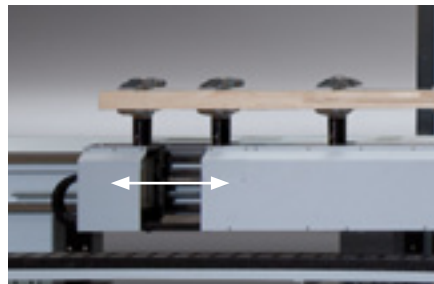

Program-controlled positionable clamping elements

Program-controlled positionable clamping elements and grippers on the handling unit ensure that the workpieces are always held with optimal side overhang.

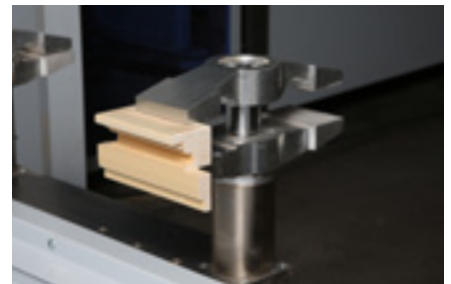

Integrated short parts

The clamping and gripping technology also enables the production of very short parts with a balustrade length from 120 mm.

Processing with performance

Secure clamping of the workpieces and powerful liquid-cooled spindles for high feed rates and perfect surfaces. This allows you to make full use of the capability of modern tool systems.

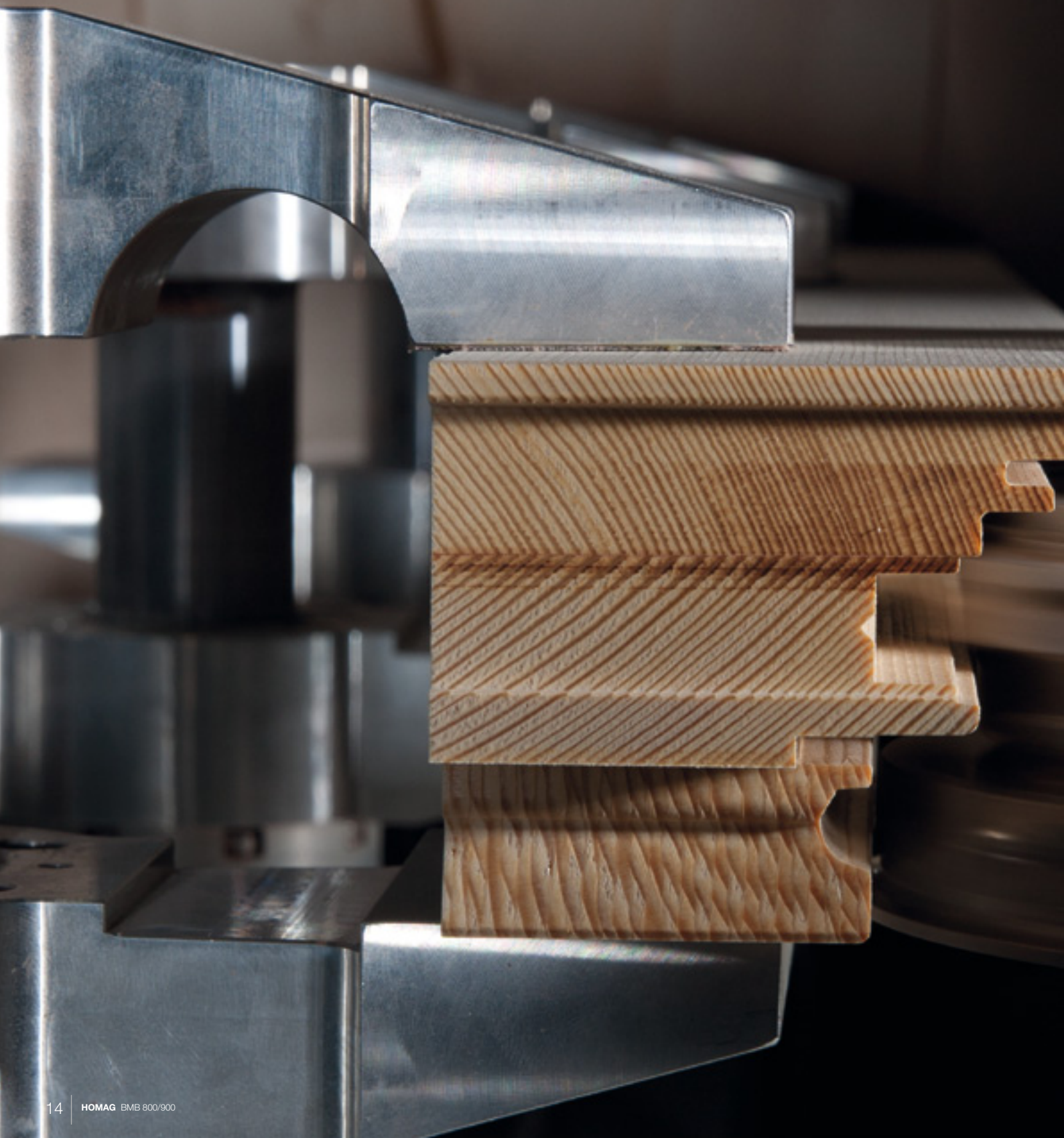



Prepared for anything: spindles, units, and tool changers.

Our impressive spindles feature liquid cooling, a variable speed range, vector control and a spindle sensor that detects imbalances and vibrations, thus protecting the spindle. The proven 5-axis technology or the FLEX5 unit family with exchangeable 5-axis technology, gives you the option of expanding the processing spectrum. What is more, the compact tool magazine, which is available in various sizes, allows you to remain flexible. The pre-changing system of the central tool magazine provides minimal clamp-to-clamp time, and all tools are located directly within reach of the trimming spindles. The nested arrangement means that all space is efficiently used, even with large tools.

Spindle sensor and chip collection

Hoods that can be steered towards the machine from both sides and a collection of residual pieces under the machine ensure the optimal disposal of chips and cutoffs. The sensor integrated in the spindle detects vibrations caused by imbalance or by inadequate workpiece clamping, thus protecting the spindle.

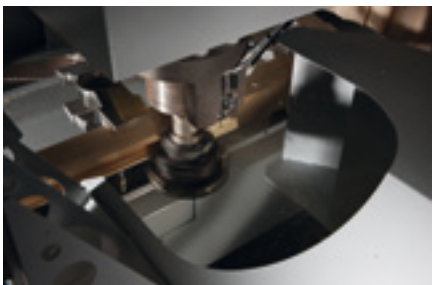

5-axis technology

DRIVE5 spindles with interpolating fifth axis reduce unit costs and increase flexibility.



FLEX5 unit technology

Sawing, routing, and drilling at any angle, optionally with automatic tool change. For inclined bore holes, slots, all kind of cuts and connection trimmings.

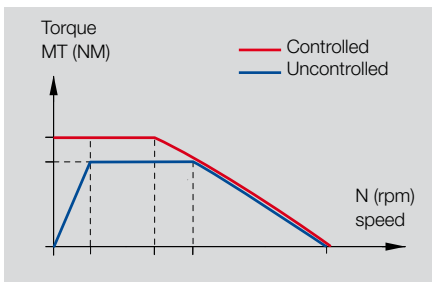

Spindles with vector control

Liquid-cooled spindles with optimized characteristic curve for high torque in the working range and stable running under heavy load by means of a vector controller with encoder return.



Underfloor routing unit

For routing and drilling workpieces from the underside, for example handle cut-outs for lifting/sliding doors without having to turn the workpieces.



Drilling unit 3+1 spindles

Efficient drilling for corners, sash bars and mullions. Multiple bore holes in one cycle using versions with 20 mm or 32 mm grids.

Tool management (optional)

- Automatic detection of tools via data chip
- Synchronization with tool database
- Avoidance of operating errors

Pre-changing system

The next tool is prepared while the machine is working. The actual change only involves reclamping, allowing you to achieve the shortest possible tool change times.

Large capacity

The large distance between the chucks means that every available space can be utilized. Nesting allows even large slot and pin tools to be accommodated. Equally, there is also space for twinned, long tools.



Everything in one machine

Arches, doors and supplementary elements. You do not need a second machine, a table is enough! An extension to a complete system with all possibilities of a common CNC processing center.

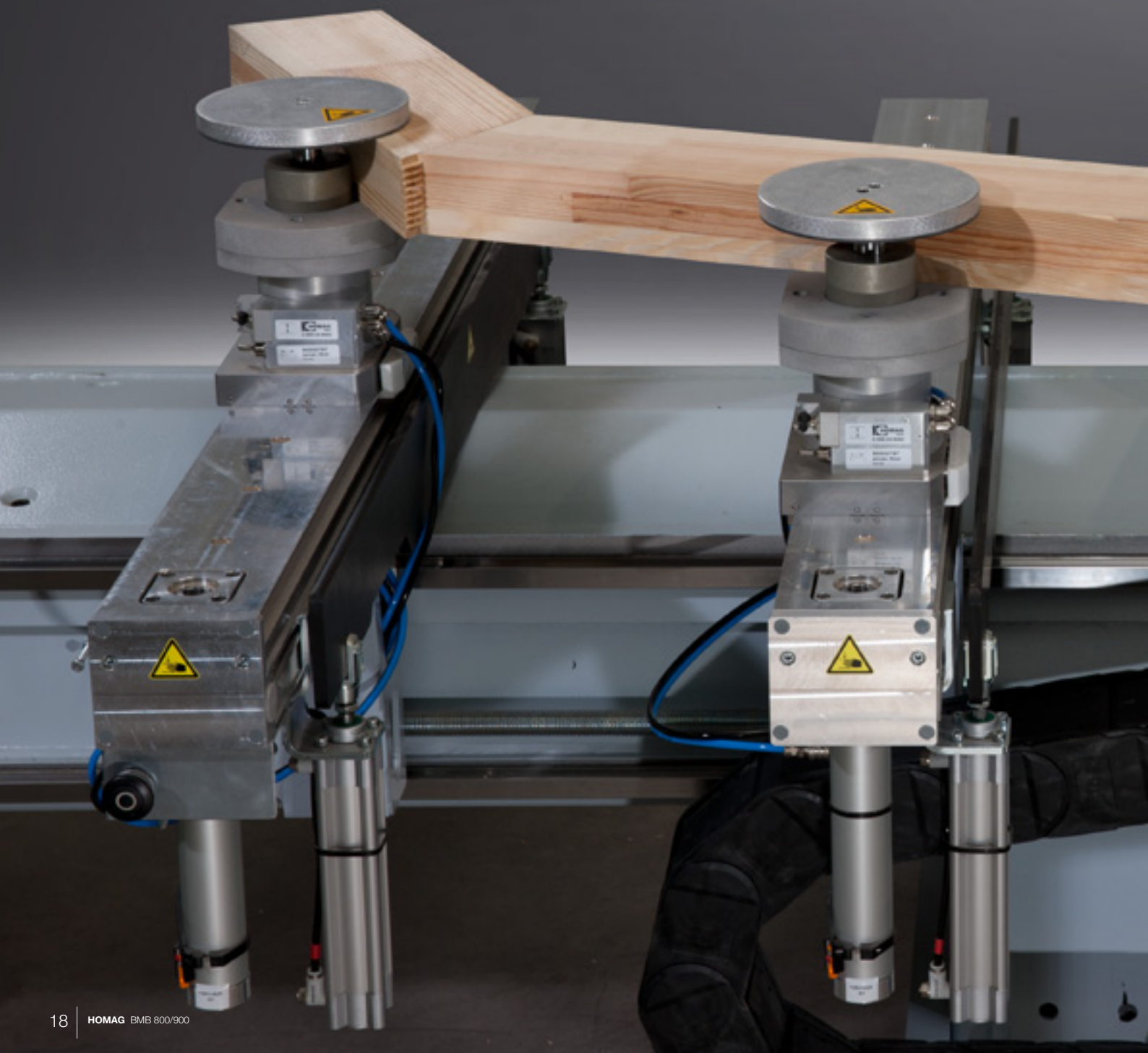

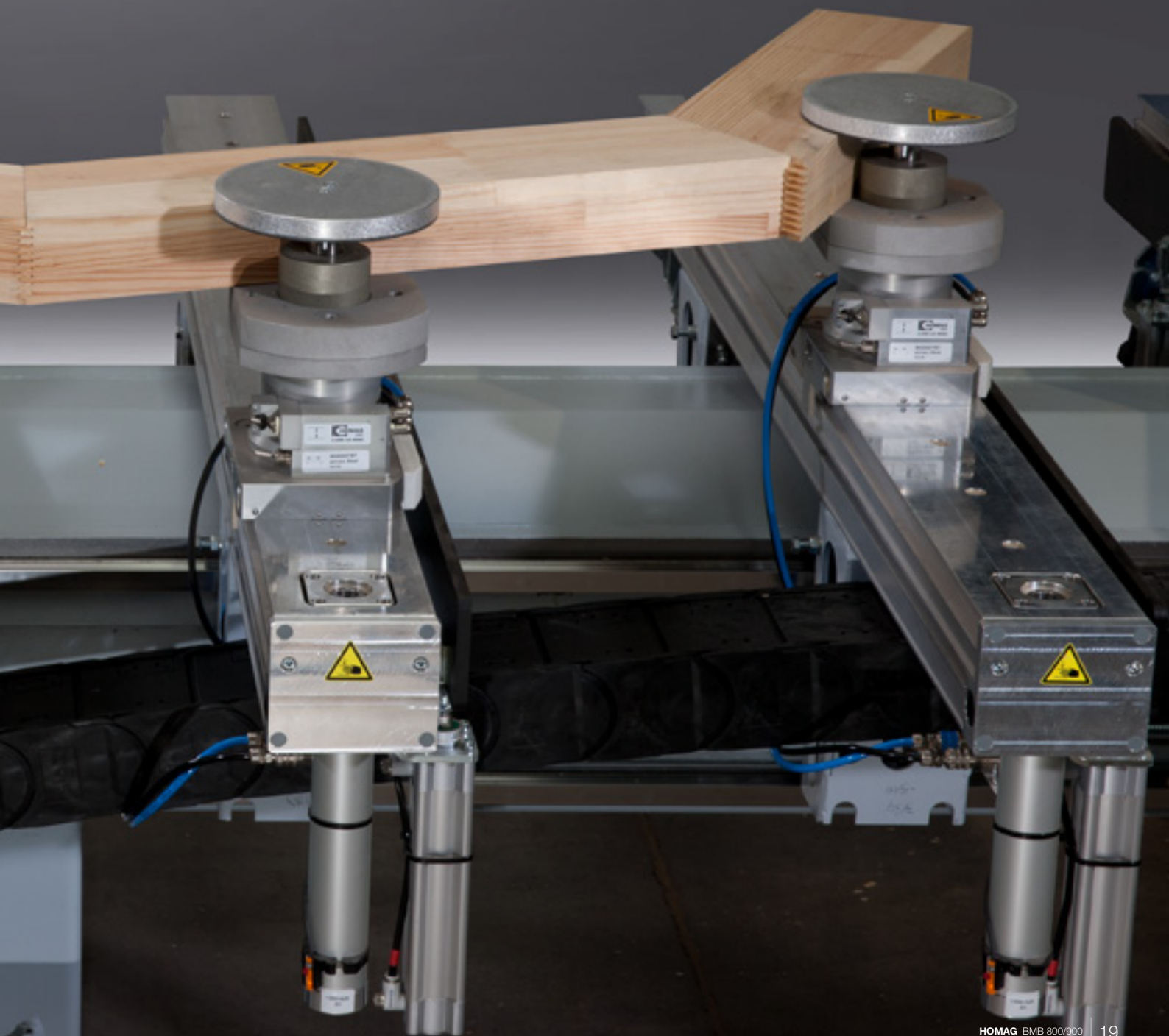

More than just straight parts

Are you looking for a solution for arches, doors and special parts? Then the additional table is exactly right for you. Consoles with stop pins turn the powerProfiler into a fully fledged CNC machining center. One machine, one data interface, one tool set.

Arches

The complete processing of curved elements with a pitch of up to 1300 mm in one piece reduces production times and manual effort (there is no need to plaster any joints). Of course, this is inclusive of the appropriate glass fixing rail.



Projection laser

So that unprocessed material is optimally utilized and securely positioned, the clamping elements and the unprocessed parts are aligned for curve processing with the help of a projection laser.



Doors

The complete processing of front door panels for independence and creative design possibilities.



Fillings

Fillings, trims and additional surface elements.

Options

The powerProfiler is a decision for the future. Additional options allow you to strategically expand functionality and convenience.

Ascending conveyor for chips and cutoffs

Waste pieces from the collecting channel under the machine can be fed directly into a container or cart via an ascending conveyor.

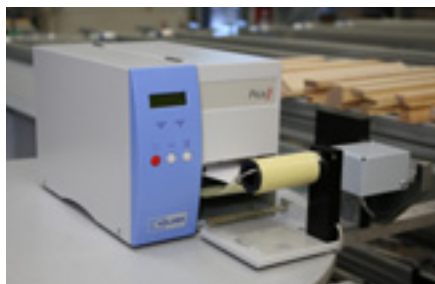
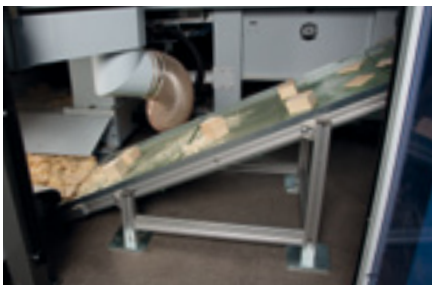

Label printer

Part tracking made easy: A printer at the outfeed allows labels to be directly generated in the correct sequence as the parts are removed.

Tool cleaning system

Clean tools overnight. The ultrasonic cleaning device integrated into the machine allows tools to be cleaned without manual intervention. This simplifies exchanging the cutting disks and provides a long service life with high surface quality.

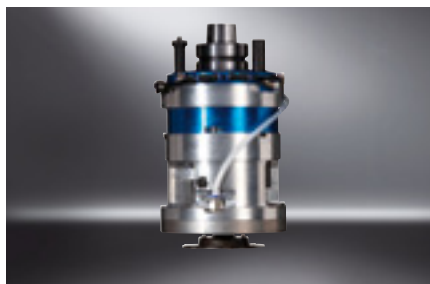
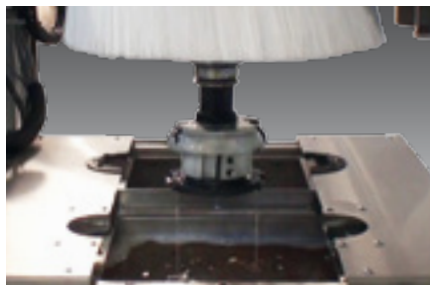

Vertically traced trimming unit

A variety of units can be used and also retrofitted to expand the functional scope of the machines. For example, for sanding or traced trimming of decorative grooves in house doors.

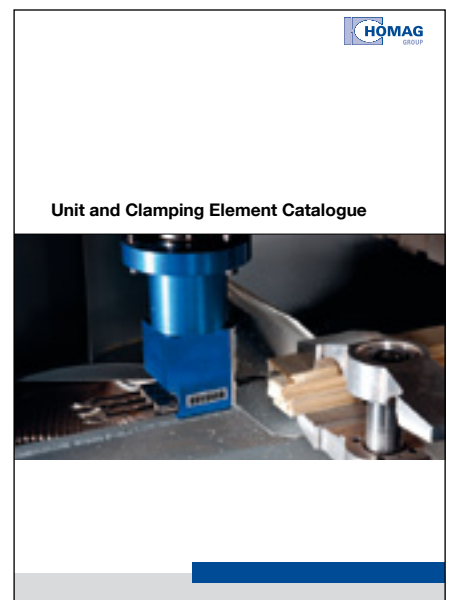

Catalog of units and clamping equipment

Further information and a wide range of options can be found in our catalog of units and clamping equipment.

Scalable performance

Do you want to produce 15 or 50 window units per shift? The performance and processing range of the BMB 800/900 series can be tailored to meet your needs.

Do you want to integrate your processing center into an overall system and interlink it with the moulder, cross cut saw or flowcoater? Or expand the shift performance? Our team at HOMAG Systems will work with you to create the best possible overall concept to meet your requirements.

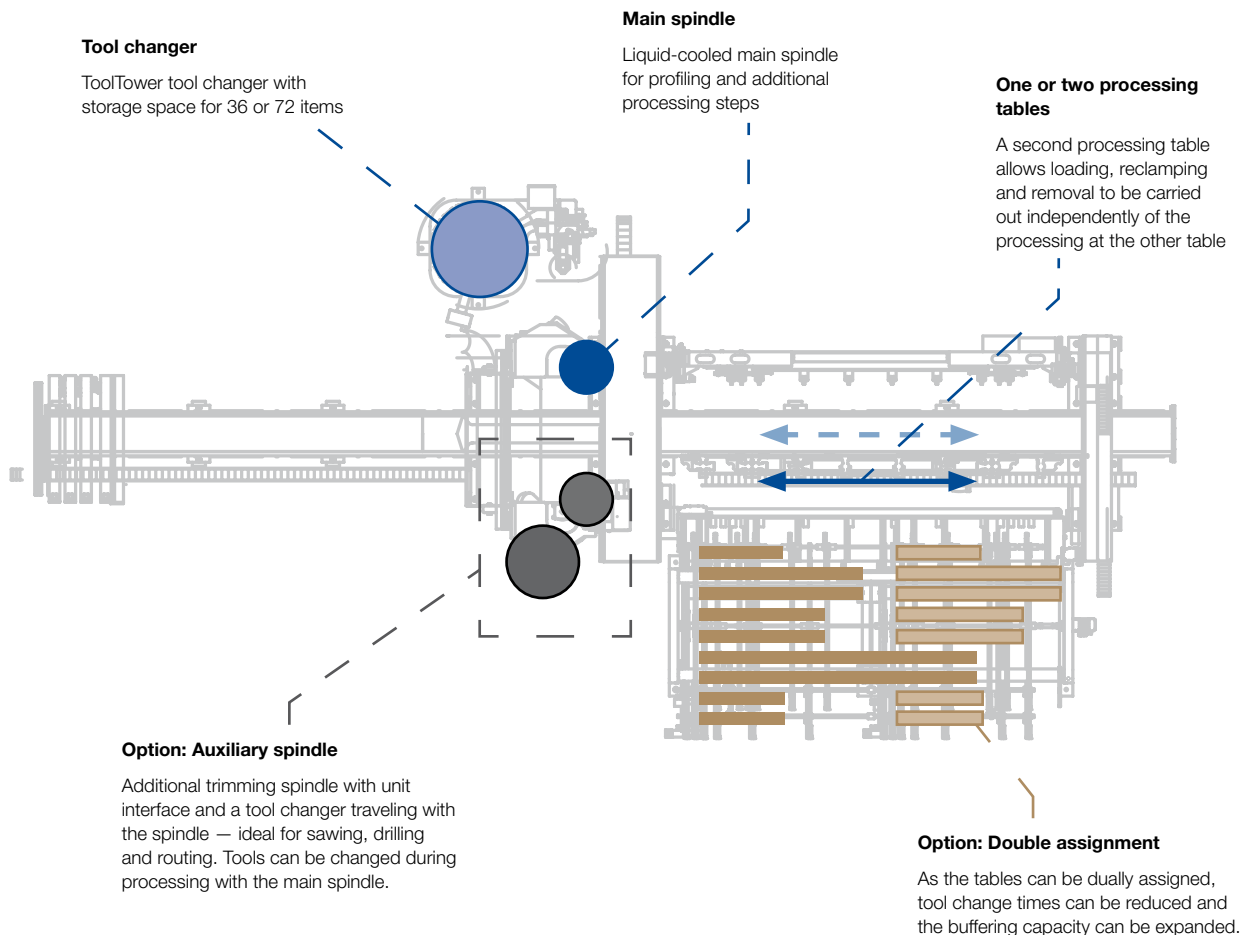



Scalable autonomy

Due to the extended depth of the infeeds and outfeeds, the autonomy of the machine can be increased. Loading and unloading becomes a minor matter, machine operation, quality control and additional activities become the main focus. Furthermore, by using break times and extending the shift times, the run time of the machine can be increased without any additional effort.

Outfeed belt

Angular transfers and outfeed belts allow the interlinking of a moulder, cross cut saw or flowcoater.



Easy. Efficient. Effective.

HOMAG software solutions.

Our processing centres are one thing – the software needed for their convenient, simple operation day in, day out is another. This is why HOMAG software guarantees extreme flexibility and operating reliability. A matter of course at HOMAG: interfaces to external programming and design systems, help programs for interleaving and modules to help you monitor your machine and track its performance.

powerTouch is the operating philosophy of the HOMAG Group. It combines design and function to create a completely new control generation. The new system is characterized by the full HD multitouch monitor, ergonomic touch operation, simple navigation and the standardized user interface.

woodFlex

Production line control unit for the effective execution of production lists with graphical part visualization and tracking on the machine display. Thus, it is clear which part is at which point in the machine.

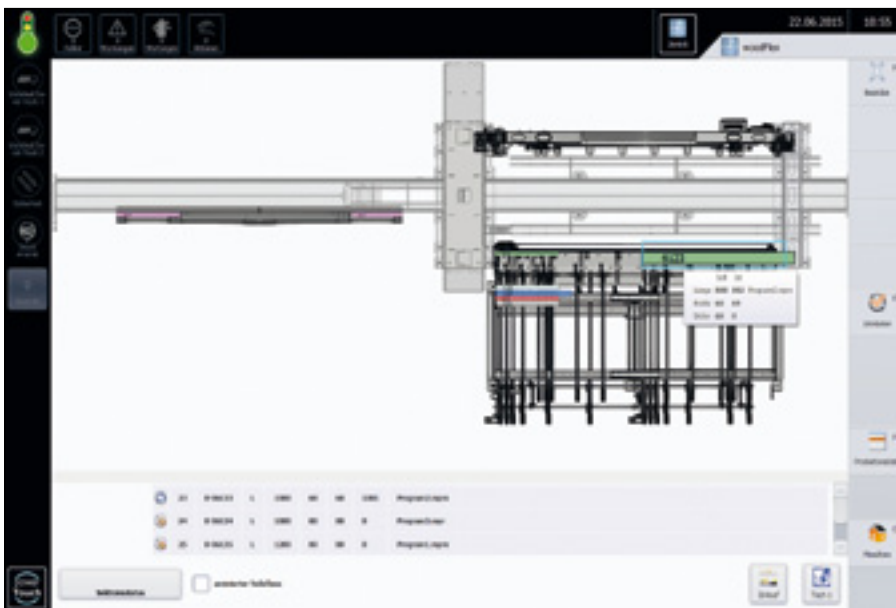

woodFlex enables integration into production lines with upstream and downstream machines (e.g. 4-sided plane, snipping saw etc.)

woodWOP programming system

Programming system for single parts, ideally suited for the parametric programming of special parts, e.g. special window shapes, conservatory parts, door leaves. Convenient use of macros (drilling patterns, lock casings, pocket routings etc.)

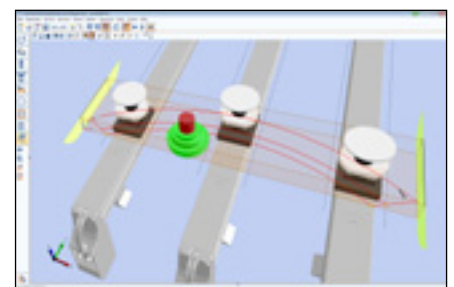
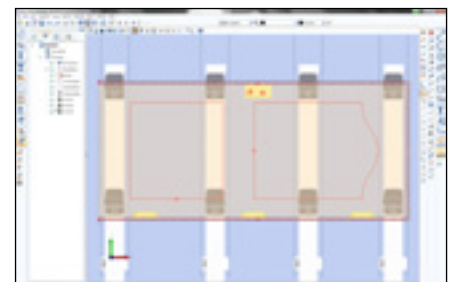



woodWOP DXF import interface for CAD data import

- Automatic generation of woodWOP programs on the basis of CAD drawings
- Assignment of processing operations using layer names
- Using DXF Import professional, all woodWOP parameters can be defined using adjustable conversion rules and transferred to woodWOP

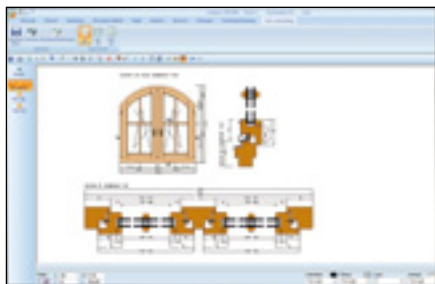
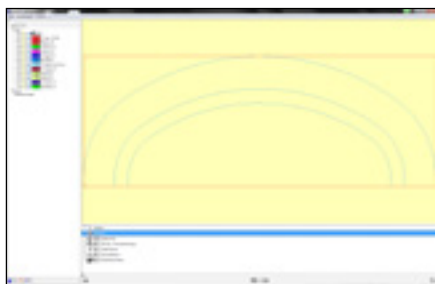

Interface to trade-specific software

For the seamless integration of the machine into the IT environment. From automatic creation of all processing programs to dynamic machine assignment with automatic identification of the position of the clamping elements and many more features for high-performance window production.

woodScout - help in your own language

- Optional high-performance diagnostic system
- Graphic display of the fault location at the machine
- Clearly understandable plain text error messages in different languages
- Learning capability through the assignment of root causes and remedial actions (expert knowledge)



Graphic tool database

- Dimensioned graphics for simple set-up and management of tools and units
- 3D view of tools

Machine data acquisition MDA – for a productive environment

- Registration of piece numbers and ACTUAL operating times at the machine
- Integrated maintenance instructions for the optimum time and quality-based planning and execution of maintenance work
- Optional professional version permits detailed breakdown and logging of registered data

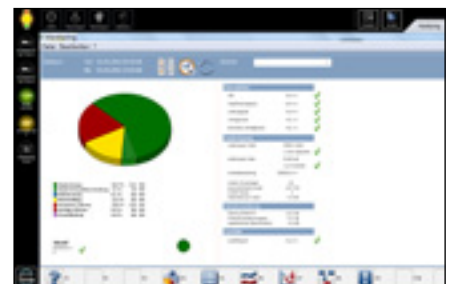

Tool service life determination

- Module for determining and logging tool service life
- Machine availability and workpiece quality are enhanced by the timely exchange of tools
- Cost reduction through optimized planning of tool deployment

HOMAG Group LifeCycleServices

The sale of our machines comes with all-in optimum service backup and individual advice. We support you with service innovations and products which are optimally tailored to your requirements. With short response times and fast customer solutions we guarantee consistently high availability and economical production - over the entire life cycle of your machine.



LifeCycleServices





HOMAG Finance – precisely the right financing

We offer you tailored financing proposals for your machinery or plants. Our financial advice goes hand in hand with our expertise relating to technical questions. Your personal contact person will take care of the whole process.

The benefit for you: The ability to invest without delay in new technologies and remain financially flexible.



Your success in best hands all over the world

The HOMAG Group is present with **1.200 service employees** around the world and also relies on more than 60 skilled partners in over 50 countries. We offer a seamless technical support network in order to guarantee the maximum availability of your machines and plants.

1,200
Service employees
around the world

85.2 %
less on-site-services through
successful remote diagnosis

650
processed spare parts
orders / day

>150 000
machines, all electronically
documented in 28 different
languages – in **eParts**

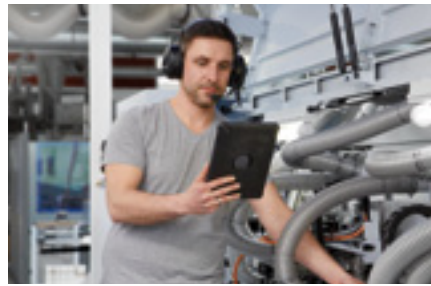

Remote Service

- Hotline support via remote diagnosis regarding for control, mechanics and process technology. Thus the on-site service can be reduced by 85.2 %!
- Mobile applications such as **ServiceBoard** reduce the costs through fast help in case of troubles with mobile live video diagnosis, online service message and the online spare parts shop eParts



Spare Part Service

- Identify, request and order spare parts around the clock via www.eParts.de
- Local availability of parts through sales and service companies as well as sales and service partners all over the world
- Reduction of downtimes through defined spare parts and wear parts kits



Modernization

- Keep your machinery up-to-date and increase your productivity as well as your product quality. This is how you can meet tomorrow's requirements today!
- We support you with upgrades, modernization as well as individual consultancy and developments



Trainings

- The trainings perfectly suit to your requirements. Through this your machine operators can operate and maintain the HOMAG Group machines optimally.
- The trainings also include customer-specific training documents with practice-proven exercises



Software

- Telephone support and consultancy through software support
- Digitalization of your spare parts via 3D scanning saves time and money compared to new programming
- Subsequent networking of your machinery with intelligent software solutions ranging from construction to production

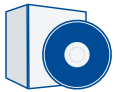

Field Service

- Increased machine availability and product quality through certified service staff.
- Regular checks through maintenance / inspection guarantee the highest quality of your products
- We offer you the highest availability of technicians in order to reduce downtimes in case of unpredictable troubles





**Choose the Original
Choose Success!**

For the Success of Original Technology
A VDMA campaign



A member of the HOMAG Group



HOMAG Holzbearbeitungssysteme GmbH

Homagstraße 3–5

72296 Schopfloch

GERMANY

Tel. +49 7443 13-0

Fax +49 7443 13-2300

info@homag.de

www.homag.com