

# k 100 evo

automatic edge bander



# All “Made in SCM Italy”

*From casting iron to finished product.*

Come see our production plants and touch the quality of SCM machines; you will be our guest.





## **Machines for the advanced joinery.**

SCM's objective is to guarantee customers high quality technologies which meet their requirements in such a way as to make SCM the partner for any needs.

# **k 100 evo**

Advanced technology, affordable price, exceptional quality.

# automatic edge bander k 100 evo



		k 100 evo
Thickness of rolled edges	mm	0,4 ÷ 3
Max. thickness of edges in strips	mm	5
Min. ÷ max. panel height	mm	8 ÷ 50
Min. panels length/width with rolled edges	mm	160 / 110
Feed speed	m/min	7

*Find the complete technical specification at page 18*



**Pre-milling Unit**  
perfect joint line



**Interchangeable Glue Pot**  
also for PU gluing



**End-Cutting Unit**  
smart solutions



**Machining Units with Automatic On/Off System**  
high performance



**Multi-radius Tool**  
great accuracy



**"eye-S" Compact Console**  
ease-of-use

Automatic edge bander with possibility of edging solid wood strips up to 5 mm thickness, features that make it the perfect machines for small woodworking furniture and panel processing companies.

# k 100 evo electronic control

edge banding technology... at your fingertips

## "eye-S" Compact Console.

Optimal managing of the machine thanks to the new 10" touch screen control panel with **Maestro active edge**, operator interface, where all of the machine functions are graphically shown. Three working modes are available: manual, program and job order.

Immediate and intuitive panel programming thanks to the adaptive 3D design of the processing with real time preview.



No possibility of error with the machining guidance system that suggests the correct machine set up to the operator.



# Maestro active edge

Maestro active is the new operator interface software which has been unified across all SCM technologies. A single operator can easily and confidently run multiple machines due to controller and interface consistency: regardless the machine, Maestro active maintains the same *look&feel*, with many identical icons and navigation buttons, thus ensuring the same approach to interaction.

## EASE OF USE

The new interface has been specifically designed and optimized for immediate use via touch screen. Graphics have been redesigned for simple and comfortable navigation, with tablet-like icons on touch screen controller.

## “ZERO” ERRORS

Improved productivity thanks to guided procedures that reduce the possibility of error from the operator's side.



# k 100 evo operating groups



designed for  
a perfect finish

## Panel Feed Speed by Track.

High productivity by the track feed speed.

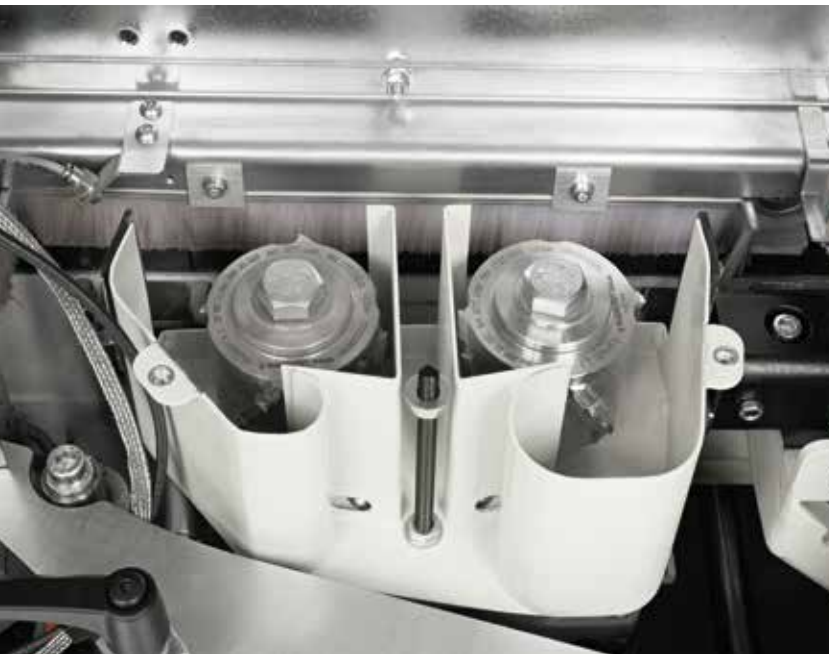

perfect edge joint line

## Pre-Milling Unit.

Panel edge surface without any imperfections before the gluing operation. It utilizes 2 tools with opposing rotation and timed intervention that, through the removal operation, corrects any panel imperfections caused by the saw cutting process and panel storage. The independent exhaust system and the air blowing device removes dust and chips from the panel.

- Diamond cutters available as standard feature

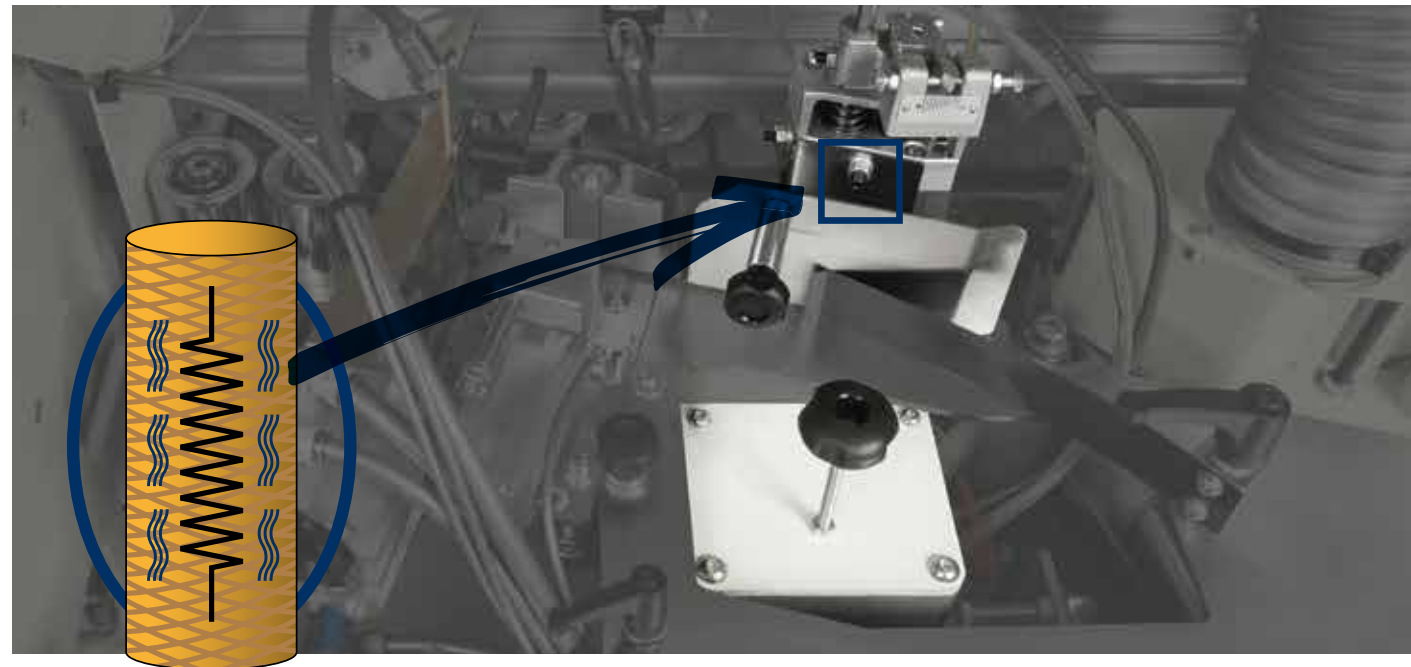

ideal edge application

## Gluing Unit.

The glue is heated rapidly and evenly by the resistances. The **automatic lowering of the glue temperature** after a temporary halt in production when using the machine avoids burning of the glue. An **innovative system of self-lubrication of the glue pot**, enables a more extensive use of the edge banding machine without the necessity of lubrication. Two rollers press the edge banding evenly and efficiently on to the panel edge. The glue spreading roller with electrical resistance inside provides a uniform glue spread and always at the maximum working temperature even on panels at the maximum working height. Glue pot rapid unlocking and PU glue pot are available.



smart solutions

**End-Cutting Unit.**

The unit is equipped with a blade and a high frequency motor to provide the **best finishing quality** of the machined edge. Furthermore, the absence of belts or other driving systems prevents any vibration assuring **the best results at all times.**



# k 100 evo operating groups

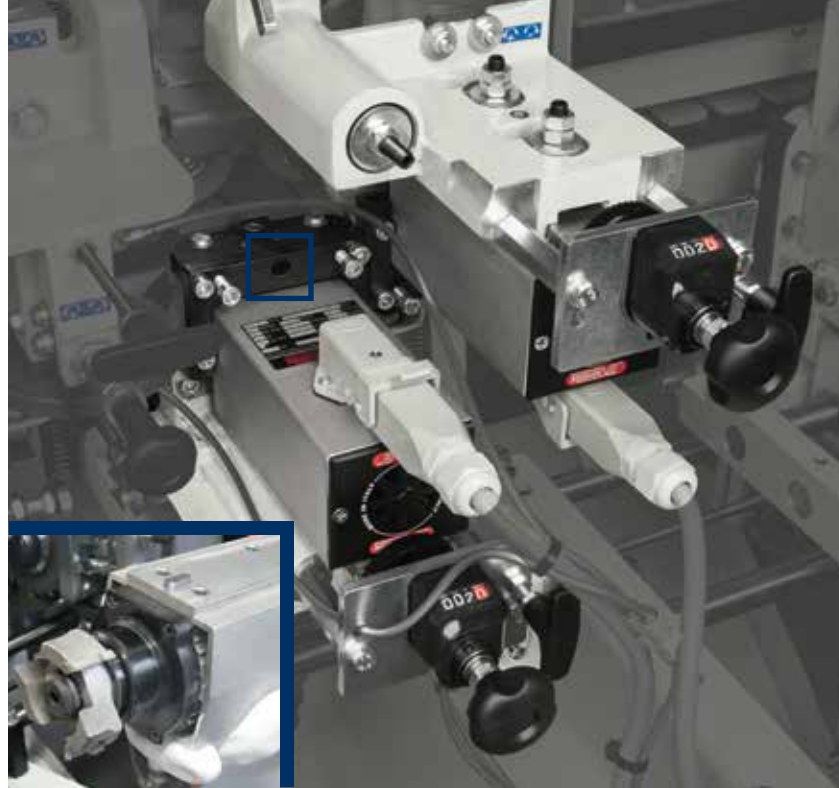

quality finishing and versatility

## Trimming Unit.

Very high edge quality finishing with **the rotating copiers**. **The high frequency motors** generate high cutter rotating speed, reducing to a minimum any marks left from trimming and guaranteeing the absence of vibrations.

High performance and rapid setting according to the working program, thanks to the new automatic system with pneumatic on/off for the trimming unit, controlled by the machine NC. *(option)*

Flexibility and accuracy to perform a radius on the edge with the multi-radius tool, available for the trimming unit: possibility of machining different edge thicknesses with automatic set up controlled by the machine NC (it is however foreseen a manual adjustment of the trimming unit for machining thin edges and with thickness included between the cutter radii). *(option)*

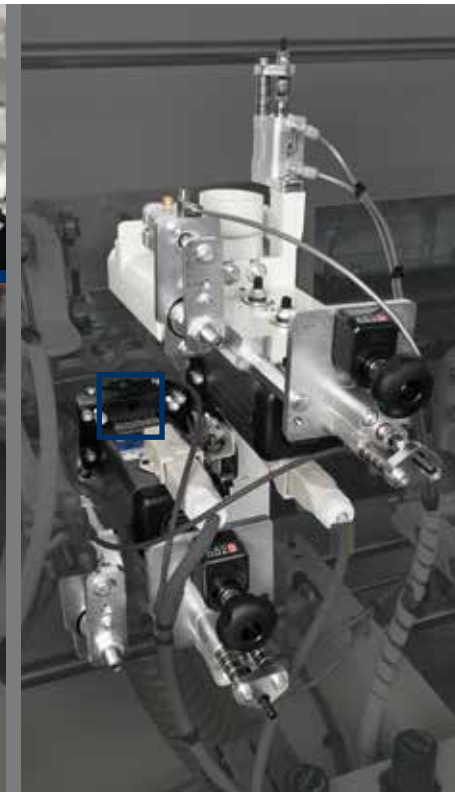
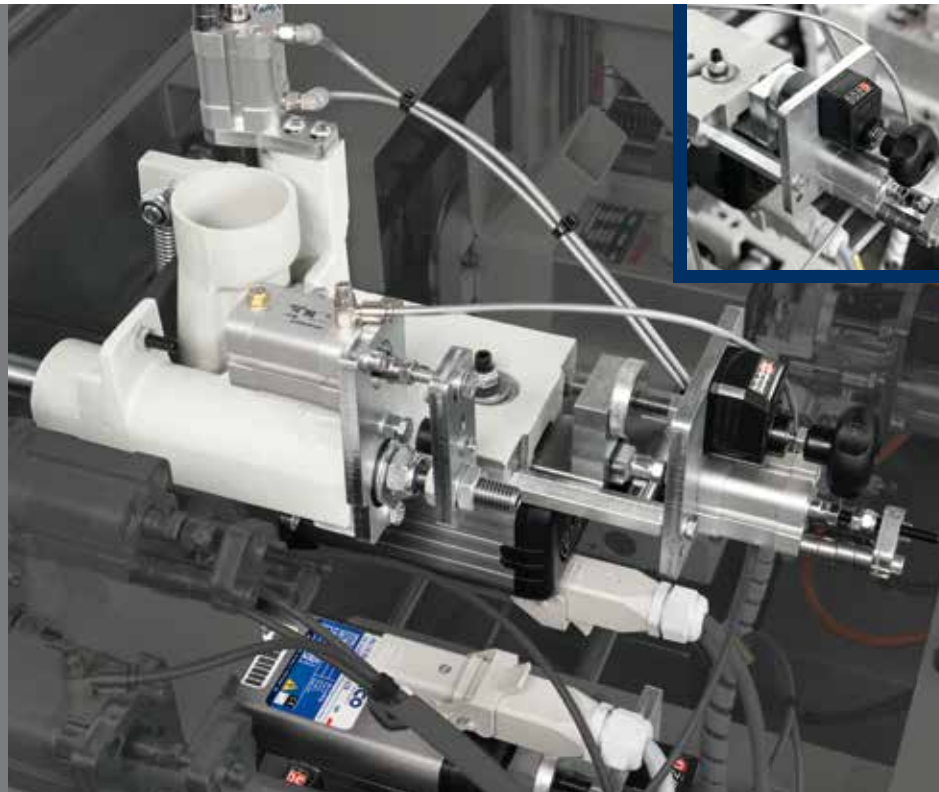



# k 100 evo optional operating groups



high finish quality

## **Panel Heating Devices.**

They considerably improve the gluing quality by heating the panel before the glue application. The IR lamp is ideal for those who work in cold environments.



ease-of-use

## **Automatic Loading for Edges in Strips.**

The solid wood strips are automatically loaded and synchronized with the introduction of the panels into the machine.

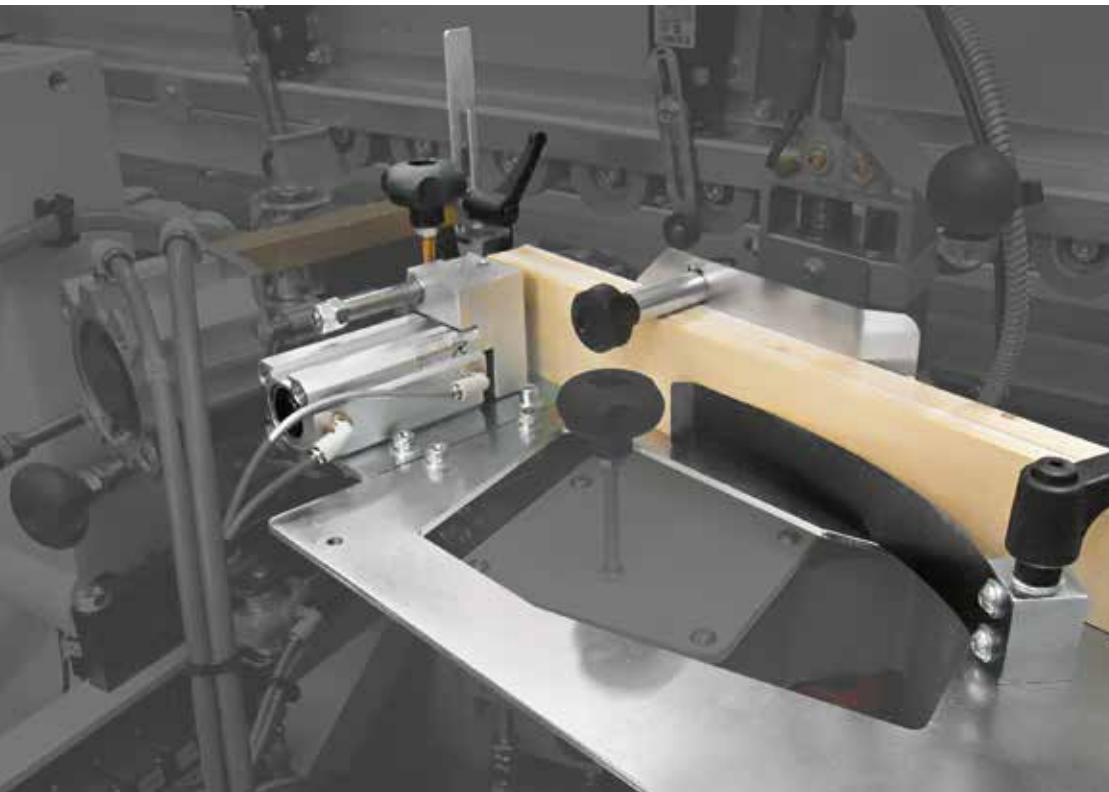

maximum efficiency

## **Glue Pot for PUR Glue with Rapid Purging System.**

It is ideal to work with polyurethane glue or when using glues of different colors. The **rapid purging system** highly increases the machine productivity, reducing downtimes for cleaning and glue replacement operations.



perfect radius on pvc/abs edges

#### Edge Scraping Unit.

High finishing quality of plastic material edges thanks to the radius knives that ensure the complete elimination of any marks left from the trimming unit tools, all equipped with a **front and vertical disc copiers**, and a user-friendly device for exclusion of the unit when it is not in use.

The **numerical indicator for the horizontal adjustment** enables a quick positioning of the unit during the processing of edges with different thicknesses.

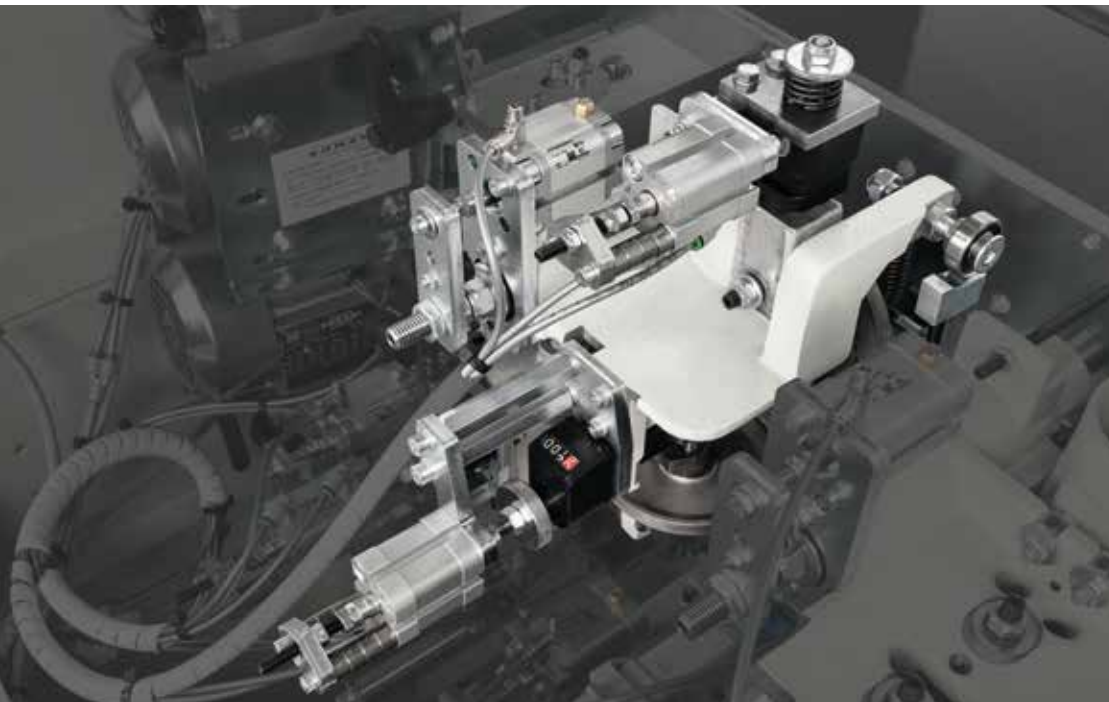
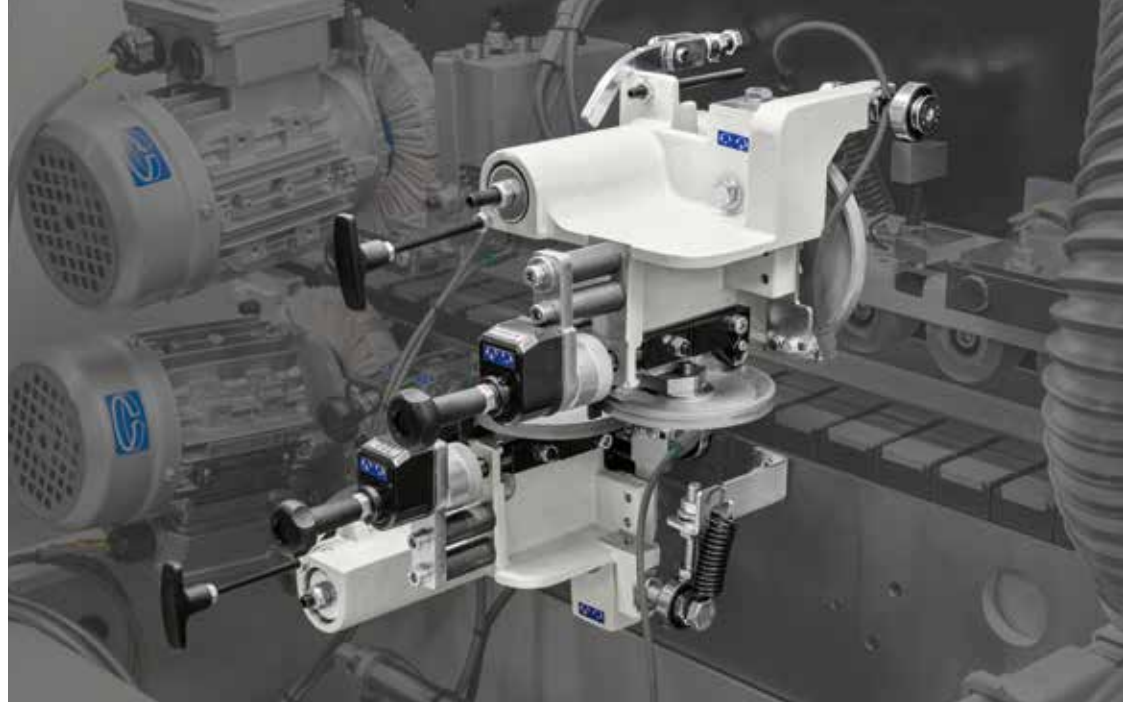

Flexibility and accuracy to perform a radius on the edge with the multi-radius tool, available for the edge scraping unit: possibility of machining different edge thicknesses with automatic set up controlled by the machine NC (it is however foreseen a manual adjustment of the edge scraping unit for machining edges with thickness included between the cutter radii).

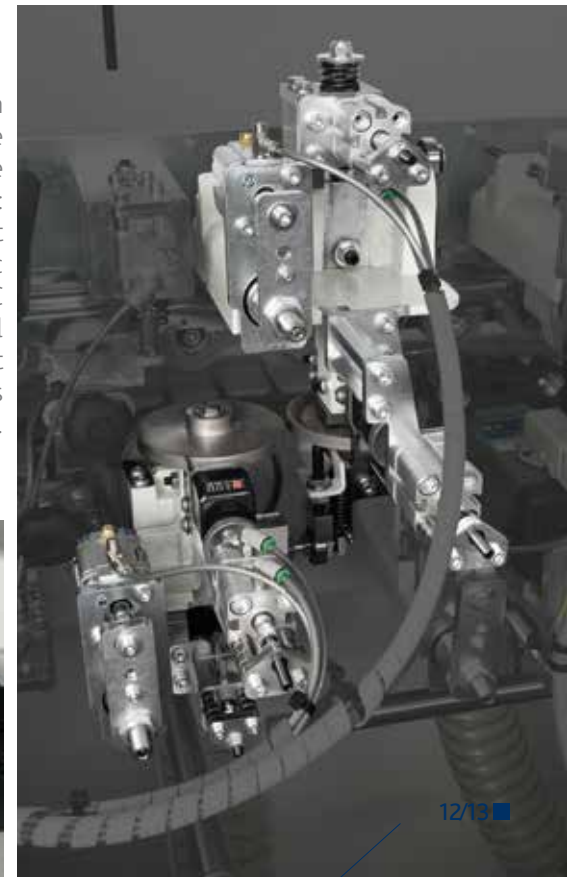

As an alternative, the edge scraping unit is also available with the new automatic system with pneumatic on/off, controlled by the machine NC.



# k 100 evo optional operating groups

optimal edge cleaning

## **Glue Scraping Unit.**

It eliminates any excess glue  
on the panel/edge joint.

The **rotating copying device**  
allows to perform even the  
most delicate panels.

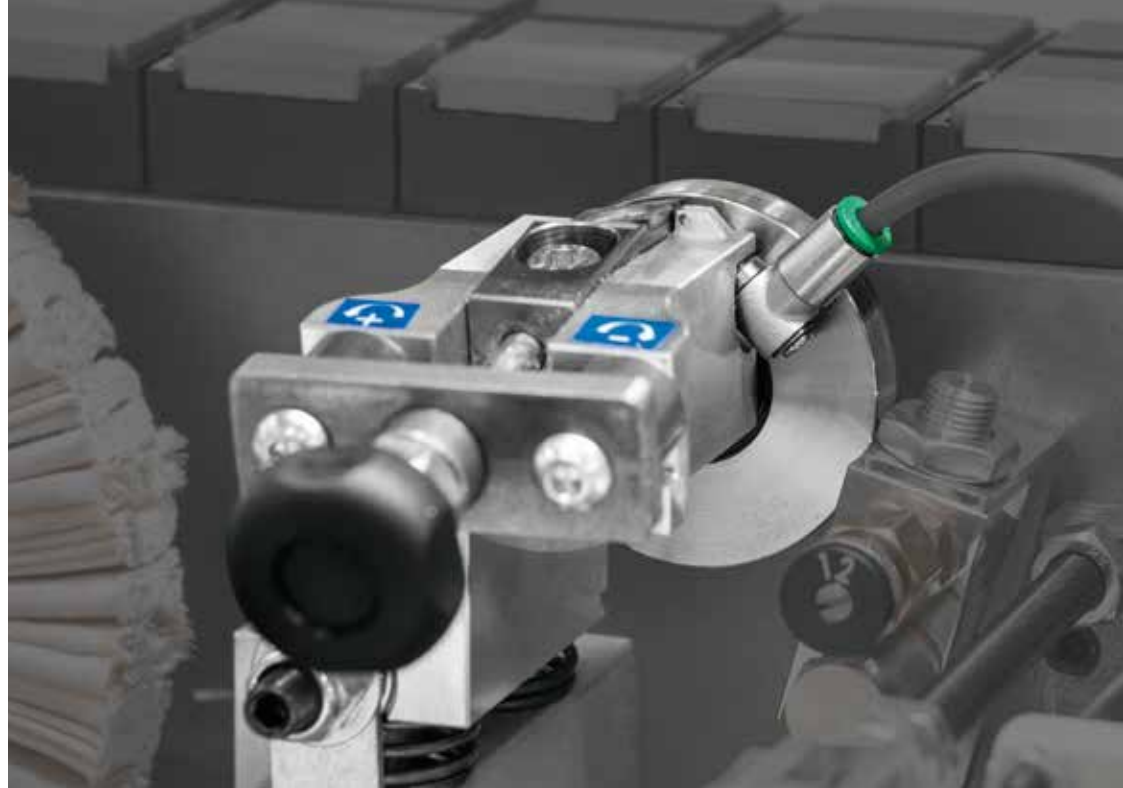

As an alternative, the glue scraping unit is also available with the new automatic system with pneumatic on/off (me 40/me 35), controlled by the machine NC.



reliable technology

**Nesting Copying Devices.**

The nesting copying devices, for the trimming unit and the edge scraping unit, enable to machine without any problem panels coming from "nesting" production cycle (with seats for hinges executed before the edge banding phase).



optimal finishing

**Brushing Unit.**

With tilted, vertically adjustable motors to optimize the cleaning/polishing action on the panel edge.



innovation at everybody's reach

**Grooving Unit.**

The optional unit is able to perform a slot on the panel directly on the edging process, **without having to sacrifice the finishing and cleaning units.**

# k 100 evo main optional devices

maximum practicality

## **"easy store" Edges Storage.**

New edges storage equipped with:

- n.7 extractable shelves
  - lower wheels for easy handling
  - a coil-holder plate with height adjustment is placed in the upper side (max. coil diameter to be loaded = 730 mm) which allows the coil-holder to be perfectly integrated with the machine
- It replace the standard coil-holder plate installed on the machine



## **"easy store" Edges Storage with Heating Function.**

New edges storage equipped with:

- n.7 extractable shelves
  - closing doors
  - lower wheels for easy handling
  - a coil-holder plate with height adjustment is placed in the upper side (max. coil diameter to be loaded = 730 mm) which allows the coil-holder to be perfectly integrated with the machine
- It replace the standard coil-holder plate installed on the machine
- heating system able to maintain a fixed temperature between 25÷30 °C and then prepare the edge for a better gluing



perfect finish quality  
**Anti-adhesive Unit  
for Edge Finishing.**  
It improve the panel cleaning  
and polishing.



ergonomic  
**Lighting of the Machine Interior.**  
The **high efficiency LED lamp**  
improves the view of the operating  
units inside the machine without  
needing to open its door.  
This device is particularly useful  
for a safe observation of the  
machine during the processing.



# k 100 evo

## dimensions and technical data

TECHNICAL DATA		k 100 evo
Worktable dimensions	mm	3000 x 525
Worktable height	mm	904
Thickness of rolled edges	mm	0,4 ÷ 3
Thickness of edges in strips	mm	5
Min. ÷ max. panel height	mm	8 ÷ 50
Min. panels length / width with rolled edges	mm	160 / 110
Feed speed	m/min	7
Feeder motor power (S1)	kW	0,55
Pneumatic operating pressure	bar	6,5
Working temperature	°C	120-220
<b>pre-milling unit</b>		
Motor power (S1)	kW	2,2
Cutters rotating speed	rpm	7.100
Diamonds cutters (standard)		N.2 Ø 80 mm H=56 Z2
Stock removals	mm	0,5 / 1 / 1,5 / 2
<b>gluing unit</b>		
Motor power (S1)	kW	0,18
Glue capacity	kg	~ 0,8
<b>end-cutting unit</b>		
Motor power ( <i>*high frequency motor</i> )	kW	0,2
End-cutting blade		Ø 125 mm Z20
Blade rotating speed	rpm	12.000
<b>trimming unit</b>		
Upper and lower motor power ( <i>*high frequency motors</i> )	kW	2 x 0,35*
Diamond cutters		Ø 55,3 mm Z3
Cutters rotating speed	rpm	12.000
<b>additional technical features</b>		
Exhaust outlets pre-milling unit, number / diameter	n./mm	2 / 80
Exhaust outlet gluing unit, diameter	mm	60
Exhaust outlets trimming unit, number / diameter	n./mm	2 / 60

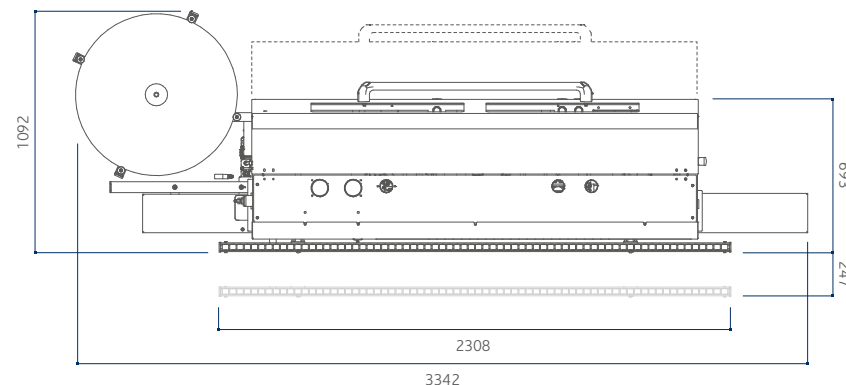
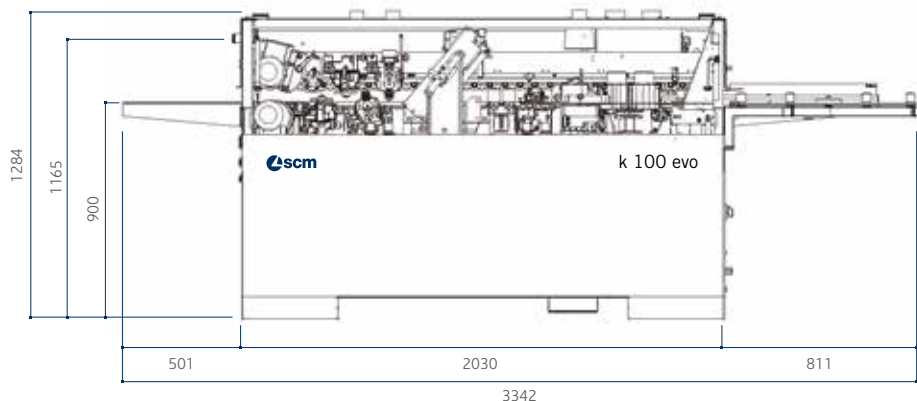

#### EQUIPMENT AND OPTIONAL DEVICES

	k 100 evo
Electronic Control with "eye-S" Compact Console	S
Anti-adhesive Unit	O
Pre-Milling Unit	S
Panel Heating System	O
IR Lamp	O
Automatic Loading for Edges in Strips	S
Automatic Loading for Edges in Strips with Storage	O
Gluing Unit	S
Glue Pot for PUR Glue with Rapid Purging System	O
End-Cutting Unit with Shear Device	S
Trimming Unit	S
Trimming Unit with On/Off System	O
Trimming Unit with On/Off System and Automatic Set Up of the Multi-radius Tool	O
Nesting Copying Device for Trimming Unit	O
Edge Scraping Unit	O
Edge Scraping Unit with On/Off System	O
Edge Scraping with On/Off System and Automatic Set Up of the Multi-radius Tool	O
Nesting Copying Device for Edge Scraping Unit	O
Glue Scraping Unit	O
Glue Scraping Unit with On/Off System	O
Brushing Unit	O
Grooving Unit	O
"easy store" Edges Storage	O
"easy store" Edges Storage with Heating Function	O
Lighting of the Machine Interior	O

- S Standard
- O Option

The motors powers in this catalogue are expressed in S6, except where otherwise specified.

In this catalogue, machines are shown in CE configuration and with options.

We reserve the right to modify technical specifications without prior notice, provided that such modifications do not affect safety as per CE norms.



**SERVICE AND MAINTENANCE**



**TRAINING SERVICE**



**SPARE PARTS**



**DIGITAL SERVICES**

**scm** | service

**WE'LL GO THE  
EXTRA MILE  
FOR YOU**

**CONTACT**

**SCM SERVICE**

via Emilia 77 - 47921 Rimini - Italy  
tel. +39 0541 700100  
scmservice@scmgroup.com  
www.scmwood.com

**SCM SPAREPARTS**

Via Emilia, 61 - 47921 - Rimini - Italy  
tel. +39 0541 674111  
spareparts@scmgroup.com  
www.scmwood.com

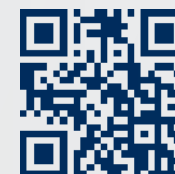

My Scm

# SCM OFFERS A FULL RANGE OF **HIGHLY SPECIALISED SERVICES** WITH A QUALITY AND RELIABILITY THAT STEM FROM 70 YEARS OF EXPERIENCE IN THE INDUSTRY.

From installation and production start-up to services and maintenance.  
From training to the supply of specific original spare parts: **we provide solutions designed around you!**



## SERVICE AND MAINTENANCE

- Remote support
- Scheduled maintenance contracts
- Warranty extension



## TRAINING SERVICE

- Courses for machine operators
- Software and programming courses
- Training in production start-up



## SPARE PARTS

- Recommended spare parts list
- E-shop
- Interactive spare-parts catalogues
- Repairs on electronic parts, glue tanks and electro-spindles



## DIGITAL SERVICES

- Maestro Connect - IoT platform to be constantly connected with your machines
- Smartech - assistance with augmented reality
- My Scm portal - opening of service ticket and single point of access to the apps and Services tools

A wooden DNA double helix structure is shown on the left side of the image, set against a solid blue background. The structure is made of light-colored wood and consists of two intertwined strands connected by horizontal rungs, mimicking the structure of a DNA molecule.

# THE STRONGEST WOOD TECHNOLOGIES ARE IN OUR DNA

## **SCM. A HERITAGE OF SKILLS IN A UNIQUE BRAND**

70 years of success gives SCM the centre stage in woodworking technology. This heritage results from bringing together the best know-how in machining and systems for wood-based manufacturing. SCM is present all over the world, brought to you by the widest distribution network in the industry.

**70** years history

**3** main production sites in Italy

**300.000** square metres of production space

**20.000** machines manufactured per year

**90%** export

**20** foreign branches

**400** agents and dealers

**500** support technicians

**500** registered patents

In **SCM's DNA** also strength and solidity of a great Group. The SCM Group is a world leader, manufacturing industrial equipment and components for machining the widest range of materials.

## SCM GROUP, A HIGHLY SKILLED TEAM EXPERT IN INDUSTRIAL MACHINES AND COMPONENTS

### INDUSTRIAL MACHINERY

Stand-alone machines, integrated systems and services dedicated to processing a wide range of materials.



WOODWORKING TECHNOLOGIES



TECHNOLOGIES FOR PROCESSING  
COMPOSITE MATERIALS, ALUMINIUM,  
PLASTIC, GLASS, STONE, METAL

### INDUSTRIAL COMPONENTS

Technological components for the Group's machines and systems, for those of third-parties and the machinery industry.



SPINDLES AND  
TECHNOLOGICAL  
COMPONENTS



ELECTRIC PANELS



METALWORK



CAST IRON



*is more*



**SCM GROUP SPA**

via Casale 450 - 47826 Villa Verucchio, Rimini - Italy  
tel. +39 0541 674111 - fax +39 0541 674274  
scm@scmgroup.com  
www.scmwood.com



00L0579741C