

# sergiani 3d form hp

hydraulic press for 3d panels laminating

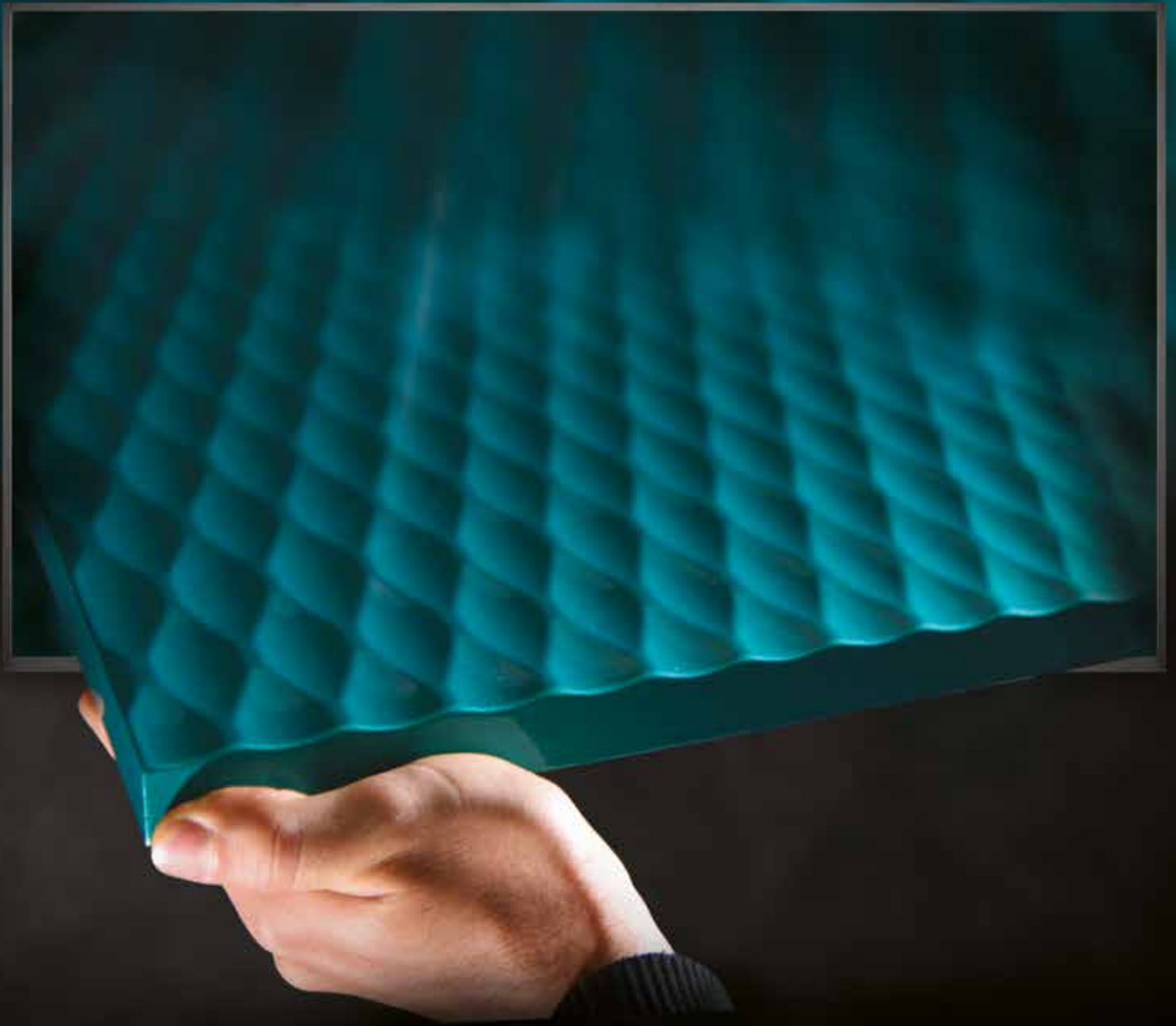

**FOR HIGH  
RESOLUTION 3D HP PANELS**



# **COMPLEX SHAPES HAVE NEVER BEEN SO DEFINED**



**WHEN HIGH PERFORMANCE IN  
PRODUCTIVITY AND QUALITY  
ARE REQUIRED**

## FLEXIBILITY



Complete offer of solutions, presses and composition lines with automations, for all applications in the wood sector.

## PRODUCTIVITY



Configuration of presses and line solutions that meet the needs of medium and large industrial manufacturing.

## POWER



Structure made of thick steel sheets to guarantee mechanical resistance to high pressure when processing.

## MADE IN ITALY



### **100% made in Italy**

More than 70 years of experience in press production to grant the highest standards in reliability and quality.

## QUALITY



Precision together with special working technologies, and the use of first quality components allow obtaining the best result with every type of coating, from the super-matt to the high-gloss.

## CUSTOMIZATION



Innovative in-line machines solutions to respond to different customers' needs with tailor-made configurations.

16

Control panel

18

Optional accessories

24

Layout and technical data

# TECHNICAL FEATURES OVERVIEW

## TECHNOLOGICAL ADVANTAGES



Loading trays are drilled in length and width in order to realize a grid where the square-headed Pin of 28 mm side are inserted, covering the entire working surface. They are automatically activated to form the counter-shape of 14mm in height depending on the position of the panel to be pressed.

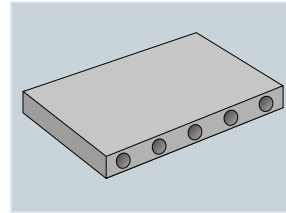

**Upper platen in solid drilled steel**  
Heated with diathermal oil for perfect temperature distribution.



**Automatic FLEXY PIN system**  
It avoids the use of counter-shapes. Loading unit with automatic PVC positioner, equipped with a system that scans panels position and, consequently, setting the FLEXY PIN in the press by a digital optical system with 28 mm pitch.

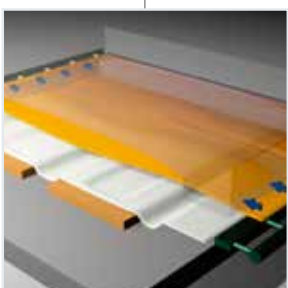
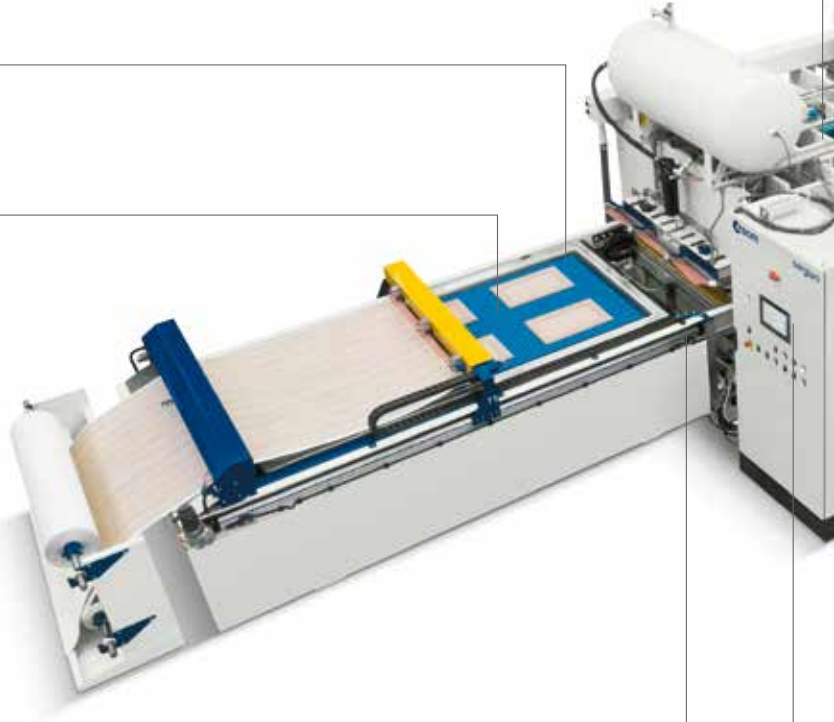

**Intermediate flange: high definition even with complex shapes**  
Possibility to work with or without membrane. In case of membrane cycle, the "intermediate flange" device allows creating vacuum between membrane and PVC, reducing the risk of wrinkles. Furthermore, it permits to execute a second pressing cycle through a cold air blast that acts directly on the PVC and separates the membrane from 3d elements.



**Control panel with Siemens colour touch screen**  
The control panel is equipped with a software that allows total control of the machine and monitoring all machine parameters in each phase of the pressing cycle.

# m h p

## sergiani 3d form hp

hydraulic press for 3d panels laminating

Vacuum and pressurised air **storage tank** to ensure an immediate and constant pressing delivery of the working chamber and a faster working cycle.



**Structure made of thick steel sheets** to guarantee greater stiffness and reliability of the structure even at high working pressures for a better quality of the pressed product.



**Automatic tilting device** with suction cups for unloading panels just pressed on the powered roller conveyor, ready to be sent to the next trimming station. (optional)



**Heat exchanger** for pressurised air heating, powered by electricity to improve gluing quality.

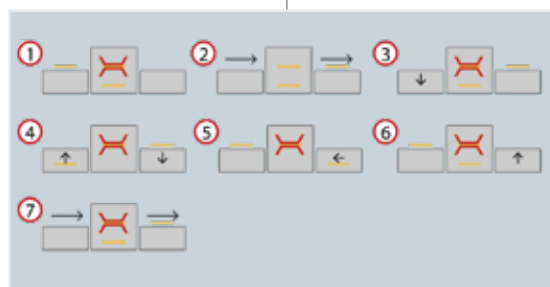

**Up to 3 trays to increase productivity**  
Trays movement inside the press is fully automatic and synchronized with loading and unloading units.

# PANELS COMPOSITION WITH FLEXY PIN SYSTEM

Rapid and effective panel composition to reduce cycle time and production wastes caused by incorrect use of counter shapes.

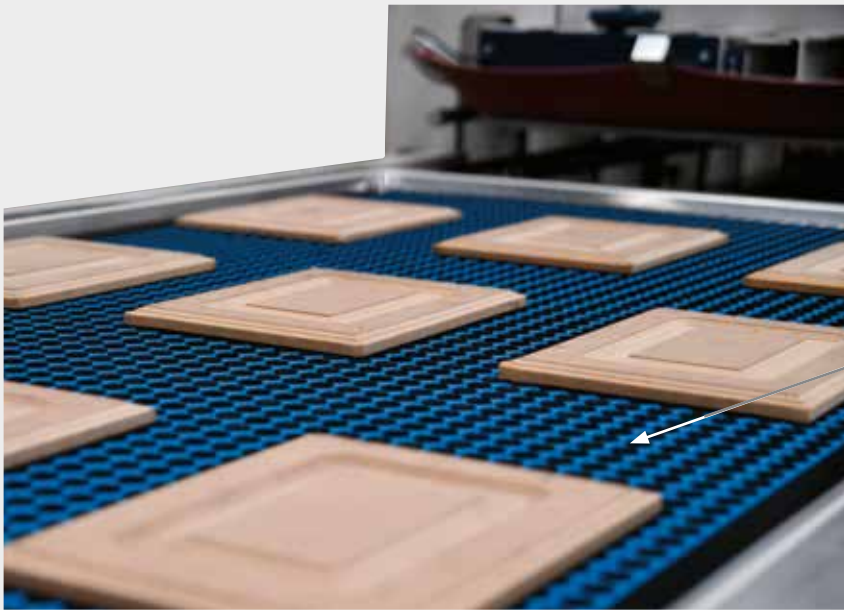

# 1



Mobile support Pin

## TRAY WITH AUTOMATIC PIN

The loading tray is composed of 28 mm side moving pins that raise the panel to be automatically veneered by 14 mm. The mobile pin is lifted by special activators inside the press.



# 3

## PIN RESET

At the end of the pressing cycle, the grid below executes the reset by raising the activators pins. The reset enables to change the type of composition at each cycle with set up times reset to zero.



# 2

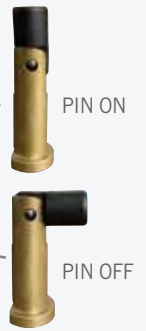
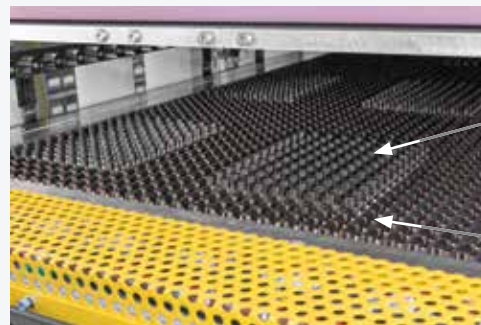
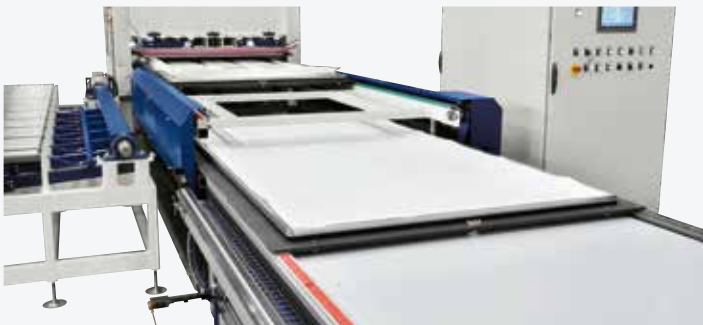

## **AUTOMATIC PVC POSITIONING AND OPTICAL SCANNING OF THE PANEL COMPOSITION**

Once the cycle start is activated, the PVC reading and positioning unit quickly scans the tray through a high-precision digital optical system and simultaneously lays the PVC coating on the tray.

## **PIN ACTIVATION IN MASKED TIME**

While the composition is being scanned, the control bar inside the press disables the unnecessary activators. All in masked time to minimize the cycle time.

# PROCESSING CYCLE WITH TWO TRAY PRESS AND LOADING FROM THE SAME SIDE

**IDEAL SOLUTION FOR THE COMPANY THAT HAS SPECIAL DEMAND FOR SPACE WITHOUT COMPROMISING ON PRODUCTIVITY.**

- The cycle starts with the tray that is prepared in the composition station and then sent to the lower daylight of the switching station (1).
- The switching station moves to the loading height of the press (2) and sends the tray inside (3).
- Then the switching station is lowered to the height of the composition station while the press is closing (4).
- The empty tray is brought to the composition station and loaded while the press starts its pressing cycle (5).
- The switching station is ready to receive both the press-out tray in the upper daylight and the new tray in the lower daylight (6).
- At this point, the switching station lifts (7) and loads the new tray into the press (8). Then the tilting device (optional) picks up the previously pressed tray and deposits it on the powered unloading roller conveyor (9).
- The cycle ends with the switching station that lowers down to allow the unloaded tray to return to the composition station to be loaded and start a new pressing cycle (10).



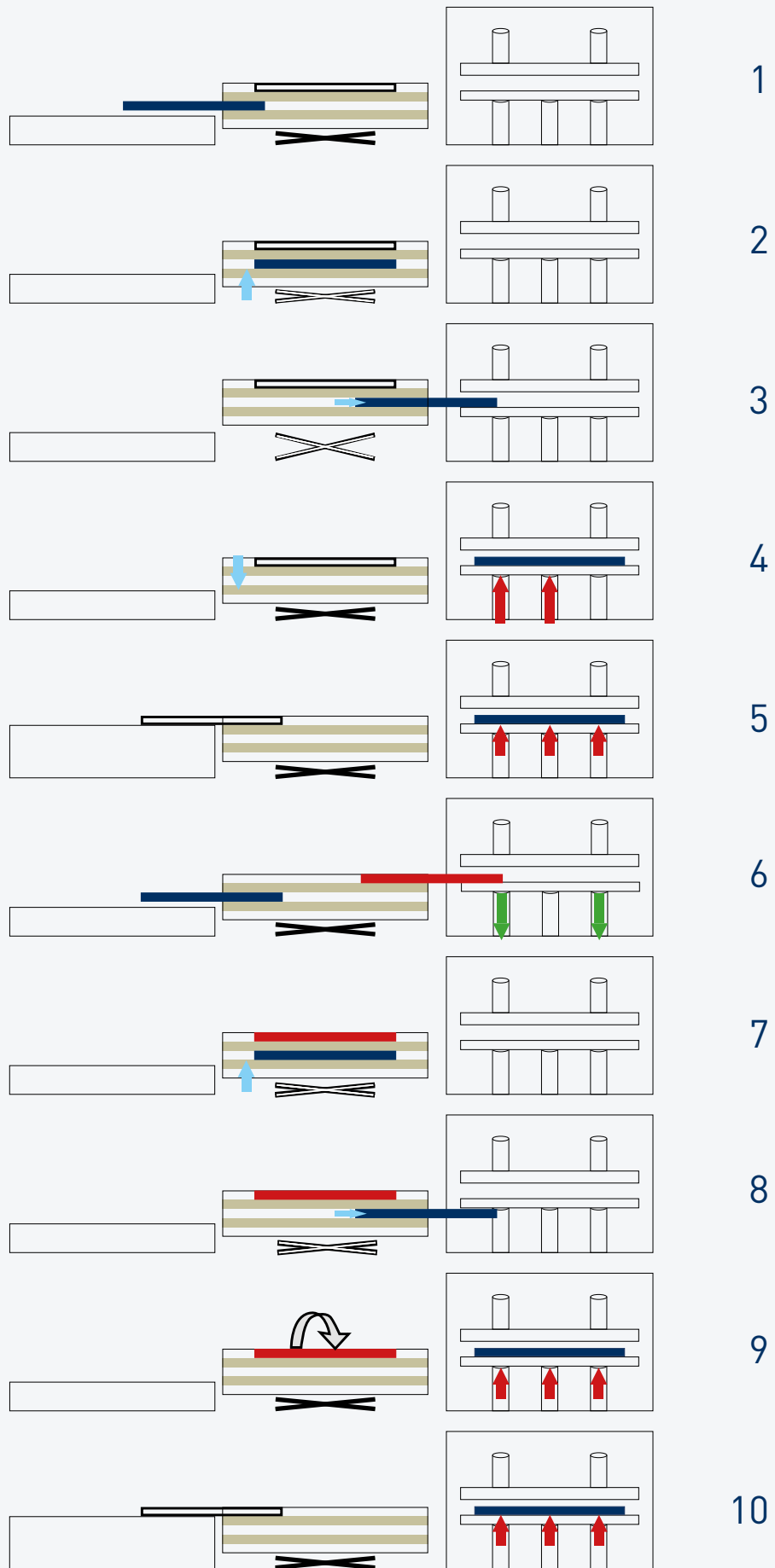

# PROCESSING CYCLE WITH THREE TRAY PRESS

**PERFECT SOLUTION FOR THE COMPANY REQUIRING HIGH PRODUCTIVITY, REDUCING DOWNTIMES AND THE CYCLE TIME AT THE PRESSING TIME ONLY.**

- The cycle starts with tray n°1 being loaded in the composition station, tray n° 2 is inside a special daylight under the press while tray n° 3 is waiting at the unloading station.
- Once loading of tray n°1 is completed, it is sent inside the press, while tray n°2 is brought to the composition station and tray n°3 is inside a special daylight below the press.
- Tray n°2 is prepared in the composition station, while the pressing cycle for tray n°1 starts.
- Once the pressing cycle is over, tray n° 1 is brought to the unloading station and simultaneously tray n° 2 is sent inside the press.
- Tray n° 2 starts the pressing cycle and tray n°1 is unloaded by the tilting table (opt.) In the meantime, tray n°3 is brought from the daylight under the press to the composition table.
- At this point the cycle starts again with tray n° 3 being loaded in the composition station while the pressing cycle for tray n°2 ends and tray n°1 is brought into the daylight below the press.

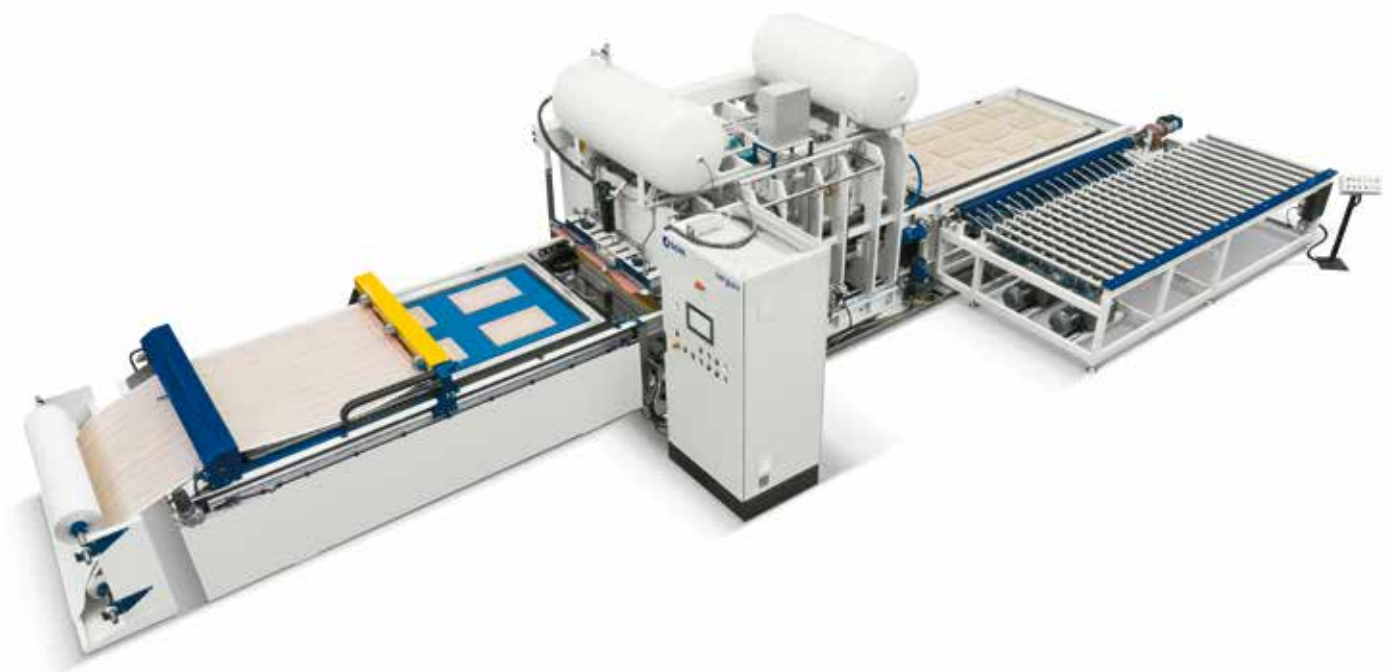

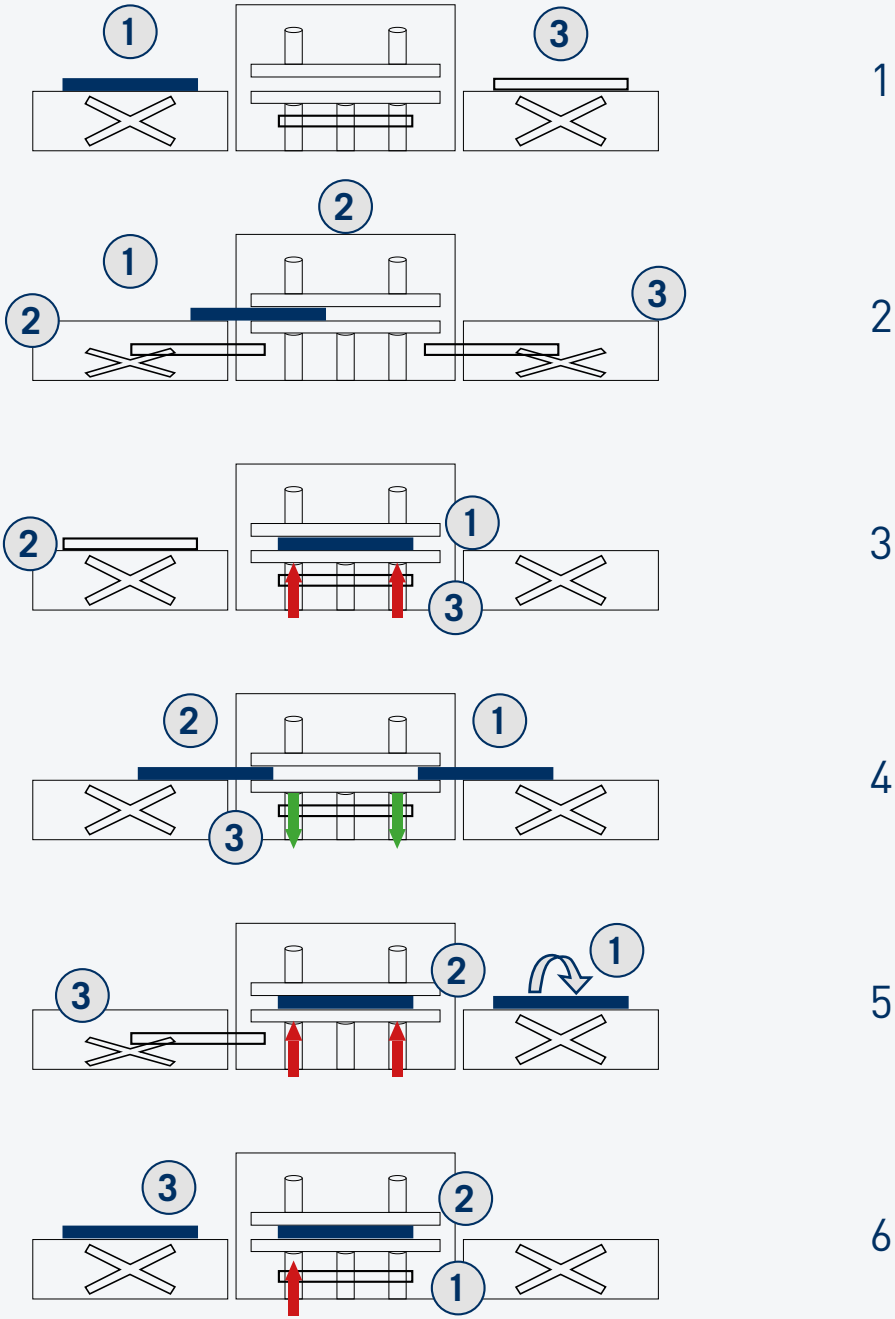

# PROCESSING CYCLE WITH INTERMEDIATE FLANGE

## HIGH DEFINITION EVEN WITH COMPLEX SHAPES

The press can work with or without the membrane.

In case of membrane processing cycle, the “intermediate flange” device creates the vacuum between the membrane and the PVC, by reducing the risk of wrinkles. Furthermore, it allows to execute a second pressing cycle through air under pressure at room temperature, that acts directly on the PVC.

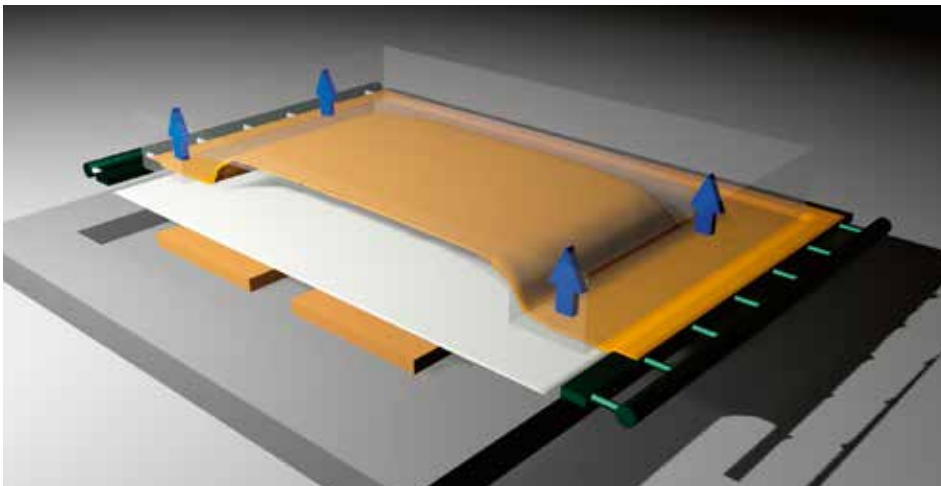

### STEP 1

Membrane is kept at the set temperature through the heat transferred from the upper chamber. When the membrane temperature falls below the set value, vacuum is created from the upper chamber and the membrane comes back into contact with the heated platen.

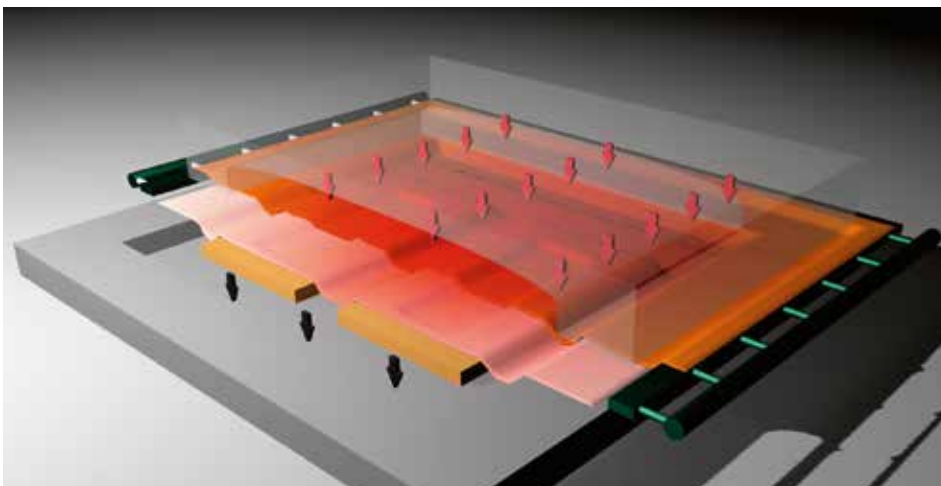

### STEP 2

Membrane is released and sent in contact with the coating sheet to begin the PVC pre-heating phase.

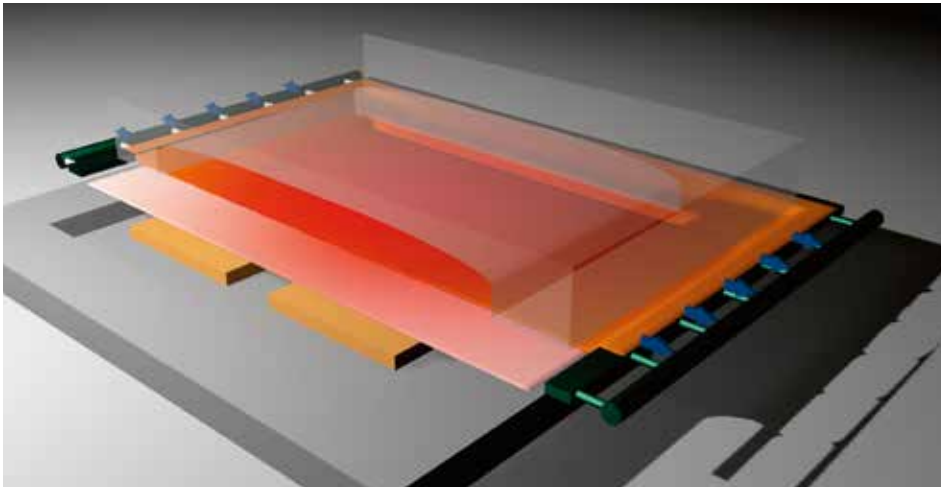

### STEP 3

The intermediate flange creates the vacuum between the membrane and the coating thus ensuring perfect contact and even heating of the coating.

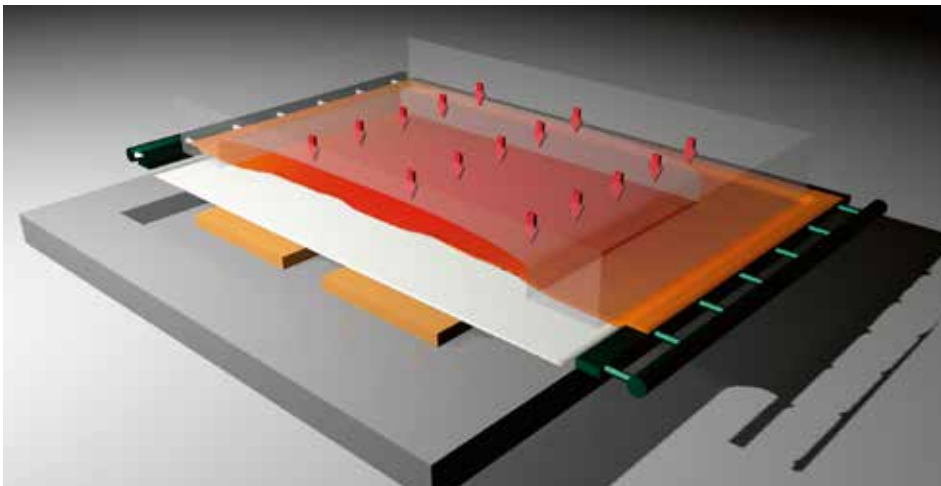

### STEP 4

The first pressing cycle begins: vacuum is created from the lower chamber and high pressure air is supplied from the upper chamber. The air storage tank ensures that the pressurized air is always ready for a constant and fast pressure supply.

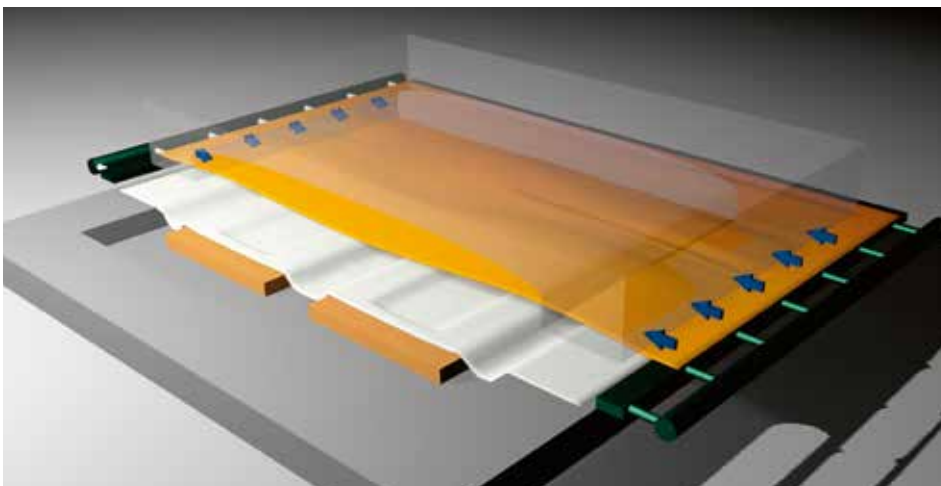

### STEP 5

The second pressing cycle begins with the intermediate flange that injects pressurized air so that the coating cools in position, for a better definition of the finished product and quality of bonding; even with complex shapes.

# CONTROL PANEL WITH SIEMENS COLOUR TOUCH SCREEN

The control panel is equipped with a software that allows total control of each machine function and monitoring all machine parameters in each phase according to the type of material to glue.



0
0

**PRESSURE TIME - PHASE 1**  
Air is fed into the upper working chamber until the set pressure is reached, at the same time vacuum is created in the lower chamber.



0	0
0	0

**PRESSURE TIME - PHASE 2**  
Air is supplied via the intermediate flange.



0
---

**PRESSURE - PHASE 1**  
This parameter sets the pressure that the membrane must exert on the material.



0
---

**PRESSURE - PHASE 2**  
The air is fed into the upper working chamber until the set pressure is reached, after the set time has elapsed the air is discharged and the press opens.







0  
0  
sec

### FLANGE VACUUM TIME

The vacuum between the membrane and the PVC is created for the duration of the set time. The membrane is in contact with the PVC.



0  
0  
sec

### UPPER CHAMBER VACUUM TIME

When the flange vacuum time expires, the material is brought into contact with the upper platen by starting the timer.

If the value is equal to zero the phase is excluded (e.g. for polished materials).



0  
0  
sec

### LOWER CHAMBER VACUUM TIME

A vacuum is created in the lower working chamber to ensure that the coating adheres correctly to the panels at every point.



0  
kg/s

### PRESSING CYCLE SPEED - PHASE 2

The higher the value, the higher the air pressure speed from the intermediate flange on the membrane and coating.



0  
kg/s

### PRESSING CYCLE SPEED - PHASE 1

The higher the value, the higher the air pressure supply speed on the membrane.



# OPTIONAL ACCESSORIES

## UNLOADING CYCLE WITH VACUUM TILTING DEVICE AND POWERED ROLLER CONVEYOR

The tilter positioned in the unloading area consists of vacuum hood for unloading and tilting the panels just pressed at the same time, depositing them on a powered roller conveyor. At this point they are ready to be sent on the next trimming station.



The new version with hoods allows a better grip even with structured PVC and eliminates the risks of marks even with the most delicate coatings.

This mechanism requires less maintenance than traditional tilting systems with suction cups.

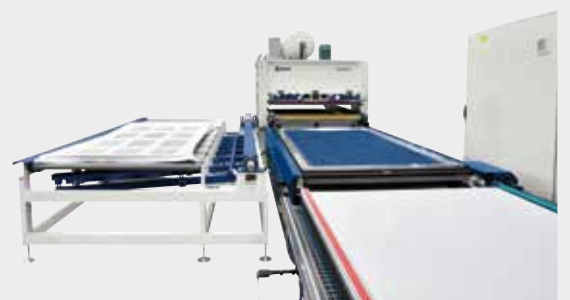

# OPTIONAL ACCESSORIES



## MEMBRANE TEMPERATURE CONTROL BY LASER

High precision system for measuring the membrane temperature through a laser, ensures greater control and optimization of the pressing cycle.

## MEMBRANE TENSIONING DEVICE

The membrane is hooked onto pneumatic cylinders that keep it constantly under tension, reducing the risks of flaws creation on the coated panels. These defects are caused by the natural membrane expansion due to the heating.





## PVC SHREDDER

It allows to reduce in small fragments the PVC waste resulting from the 3d laminating process.

## PVC UNROLLER CARRIAGE WITH N°15 ROLLERS

Up to 15 rolls can be stored in the PVC roll warehouse using a motorized chain, in order to reduce downtime due to ordinary roll replacement for exhaustion and/or production changeover.



# SCM SURFACE TECHNOLOGIES

## INTEGRATED SOLUTIONS FOR 3D PANELS CREATION

SCM stands out as a unique partner for the entire surfaces processing with all-round products and exclusive finishing solutions to meet all process and finished product type requirements.

The proposed sanding, glue application and pressing solutions make it possible to obtain a coated product on the main surface and on the edge, without interruptions of patterns and colours, and without the presence of edge joint lines, which allows to transmit original tactile and visual sensations.

3d laminating process is a mix of operations that go from the surface sanding, passing through the precise way of glue application, up to the correct pressure and temperature with which the pressing and thermoforming cycle of the coating is carried out.



dmc system t



valtorta bravorobot

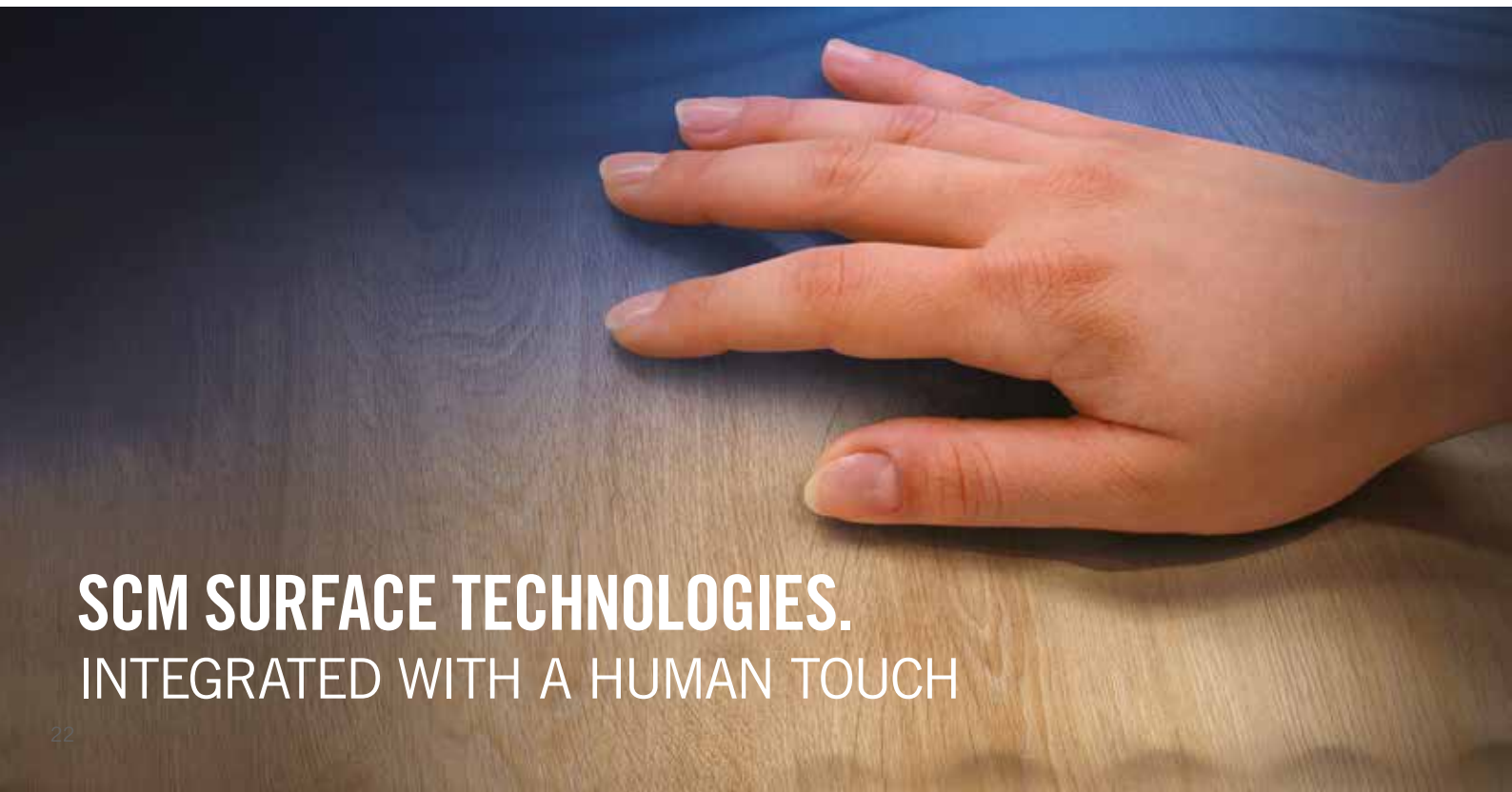

**SCM SURFACE TECHNOLOGIES.**  
INTEGRATED WITH A HUMAN TOUCH

# sergiani 3d form hp

hydraulic press for 3d panels laminating

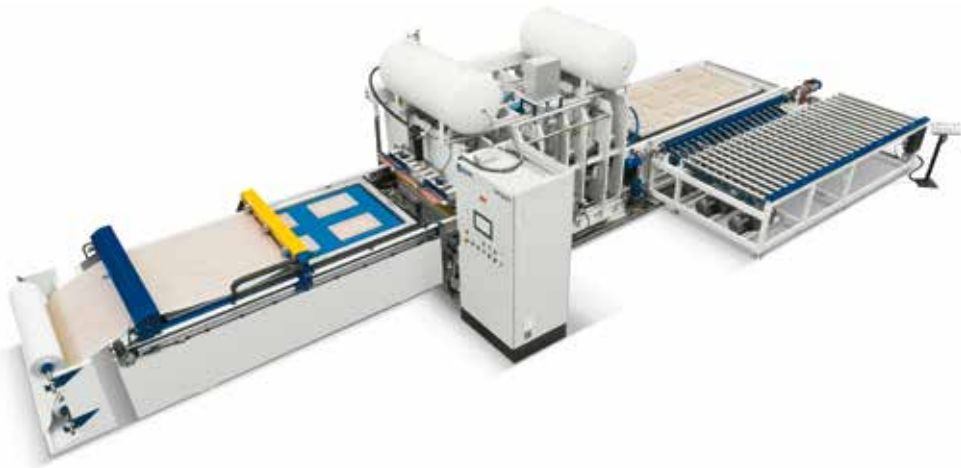

sergiani 3d form hp



# LAYOUT AND TECHNICAL DATA

## 3d form hp three tray version

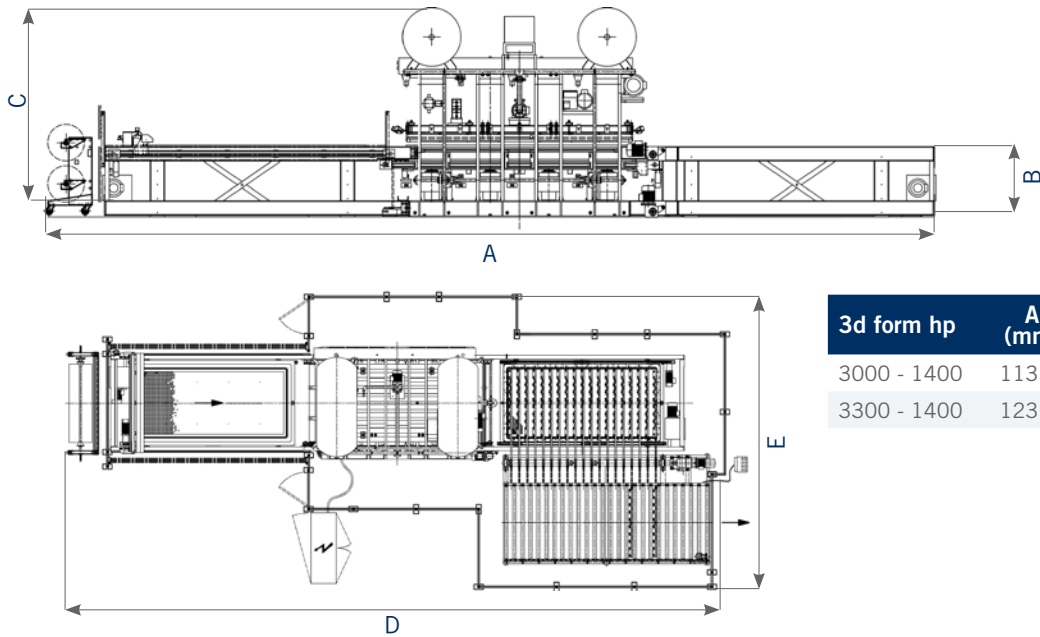

3d form hp	A (mm)	B (mm)	C (mm)	D (mm)	E (mm)
3000 - 1400	11350	1390	2850	13000	5500
3300 - 1400	12350	1320	2850	14000	5600

## 3d form hp two tray version

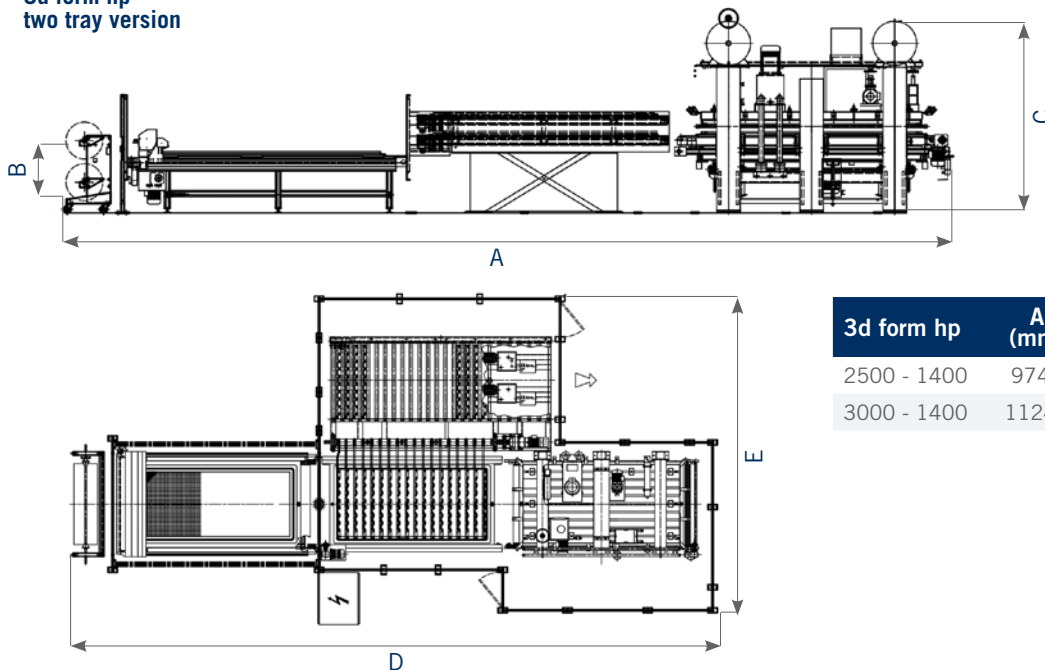

3d form hp	A (mm)	B (mm)	C (mm)	D (mm)	E (mm)
2500 - 1400	9740	940	2530	10900	6100
3000 - 1400	11240	948	2600	12400	6100

## TECHNICAL DATA

Model	Platens dimensions (mm)	Thrust (ton)	N° cylinders per diameter (mm)	Working chamber height (mm)	Specific pressure (kg/cm <sup>2</sup> )	Type of structure
3d form hp 25-14	2340x1340	200	4x140	60	5+1	Assembled beams
3d form hp 30-14	2840x1340	300	6x140	60	6+1	
3d form hp 33-14	3200x1340	400	8x140	60	6+1	
3d form hp+ 30-14	2900x1340	400	8x140	60	8+1	Ribbed
3d form hp+ 33-14	3200x1340	500	10x140	60	8+1	





**WE HAVE THE POWER  
WHEN IT COMES TO PRESSING**

# PROMPT AND EXPERT TECHNICAL SUPPORT THROUGH A NETWORK OF 1000 TECHNICIANS AND AN INVENTORY OF 36,000 SPARE PARTS.

HIGHLY SPECIALISED TECHNICIANS, EFFICIENT MANAGEMENT AND 6 SPARE PARTS BRANCHES AROUND THE WORLD GUARANTEE A CLOSE, SAFE AND EFFECTIVE TECHNICAL SUPPORT.

## SERVICE

SCM provides a service that goes beyond the purchase, to guarantee the long term performance of your technological production system and peace of mind for your business.

### A COMPLETE RANGE OF AFTER-SALES SERVICES

- installation and start-up of machines, cells, lines and systems
- tailored training programs
- telephone support to reduce times and costs when machines are not working
- preventive maintenance programs to guarantee long term performance
- complete renovation of machines and plants to renew the added value of the investments
- custom upgrading to update machines and plants and meet new production requirements

## SPARE PARTS

SCM Group can count on 140 spare parts professionals worldwide to meet any request with real time shipments.



### 36,000 SPARE PARTS

Our spare parts inventory, with a value of 12 million euros, covers every single machine



### SPARE PARTS GUARANTEED

We guarantee also hard to find parts, with 3,5 million euros invested in "critical" spare parts.



### IMMEDIATE AVAILABILITY

Over 90% of orders received are carried out the same day thanks to the huge inventory available.



### 6 BRANCHES AROUND THE WORLD

The spare parts service can count on worldwide support (Rimini, Singapore, Shenzhen, Moscow, Atlanta, São Bento do Sul)



### 500 SHIPMENTS A DAY



# THE STRONGEST WOOD TECHNOLOGIES ARE IN OUR DNA

## SCM. A HERITAGE OF SKILLS IN A UNIQUE BRAND

Over 65 years of success gives SCM the centre stage in woodworking technology. This heritage results from bringing together the best know-how in machining and systems for wood-based manufacturing. SCM is present all over the world, brought to you by the widest distribution network in the industry.

**65** years history

**3** main production sites in Italy

**300.000** square metres of production space

**20.000** machines manufactured per year

**90%** export

**20** foreign branches

**400** agents and dealers

**500** support technicians

**500** registered patents

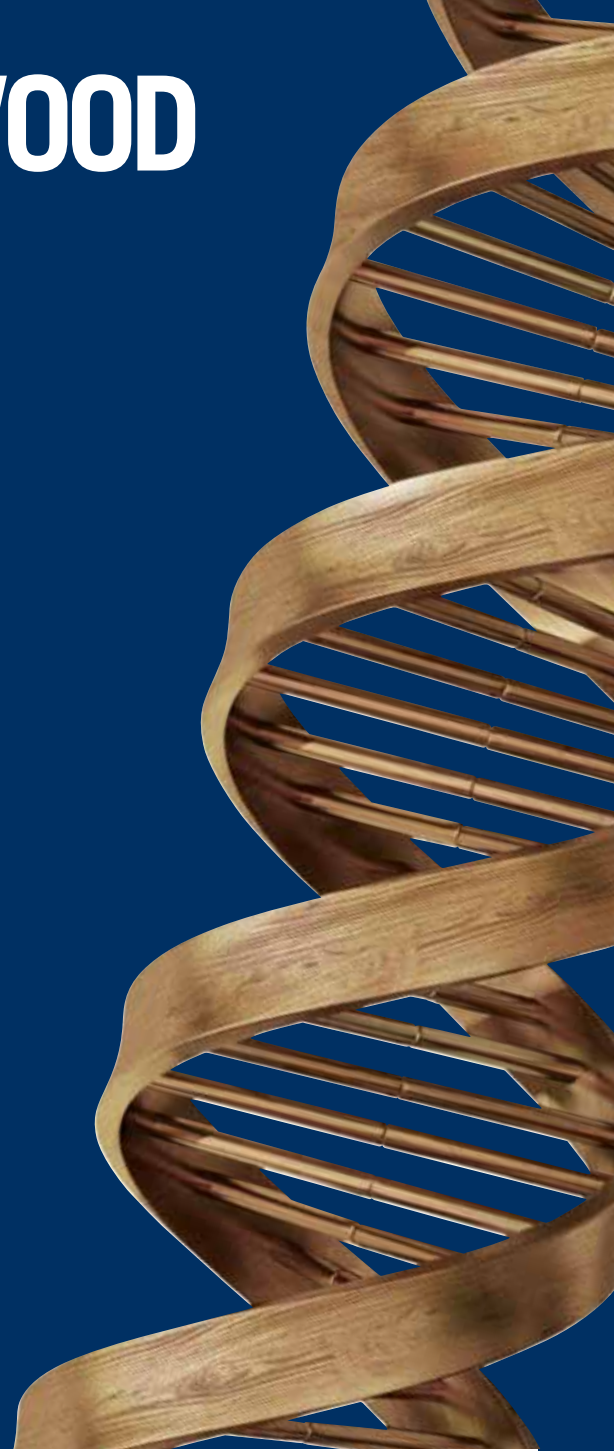

In SCM's DNA also strength and solidity of a great Group. The SCM Group is a world leader, manufacturing industrial equipment and components for machining the widest range of materials.

## SCM GROUP, A HIGHLY SKILLED TEAM EXPERT IN INDUSTRIAL MACHINES AND COMPONENTS

### INDUSTRIAL MACHINERY

Stand-alone machines, integrated systems and services dedicated to processing a wide range of materials.



WOODWORKING TECHNOLOGIES



TECHNOLOGIES FOR PROCESSING  
COMPOSITE MATERIALS, ALUMINIUM,  
PLASTIC, GLASS, STONE, METAL

### INDUSTRIAL COMPONENTS

Technological components for the Group's machines and systems, for those of third-parties and the machinery industry.



SPINDLES AND  
TECHNOLOGICAL  
COMPONENTS



ELECTRIC PANELS



METALWORK



CAST IRON



*is more*



**SCM GROUP SPA**

via Casale 450 - 47826 Villa Verucchio, Rimini - Italy  
tel. +39 0541 674111 - fax +39 0541 674274  
scm@scmgroup.com  
www.scmwood.com



00L0614922L