

Postforming



postforming

trabajo

COMPONENTES POST-FORMADOS MODERNOS Y DE ALTAS PRESTACIONES

Acabados y materiales modernos, de diseño nuevo y funcional. Con la tecnología postforming SCM se puede obtener en cualquier condición de trabajo, puertas pequeñas, puertas y planos de mesas con la más alta calidad de realización y una elevada rentabilidad en la producción masiva.





Posibilidades infinitas

Un catálogo completo de perfiles postforming son realizables con las chapeadoras postforming SCM gracias a la amplia gama de dispositivos especialmente desarrollados y para ser equipados de forma modular y personalizada en las distintas plataformas.

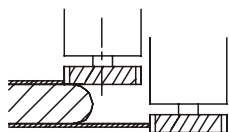
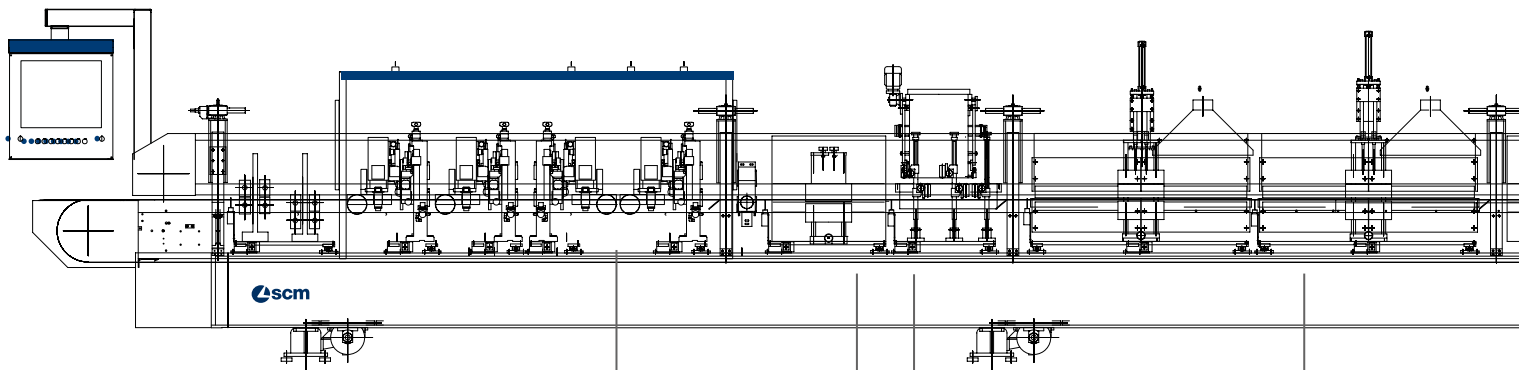

Zona de preparación laminado

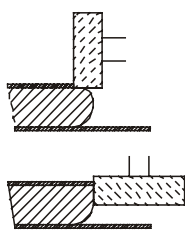

Zona de aplicación cola superficies planas

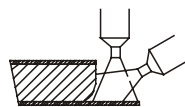

Zona de aplicación cola superficies no planas

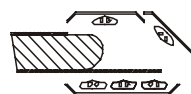

Zona de reblandecimiento laminado



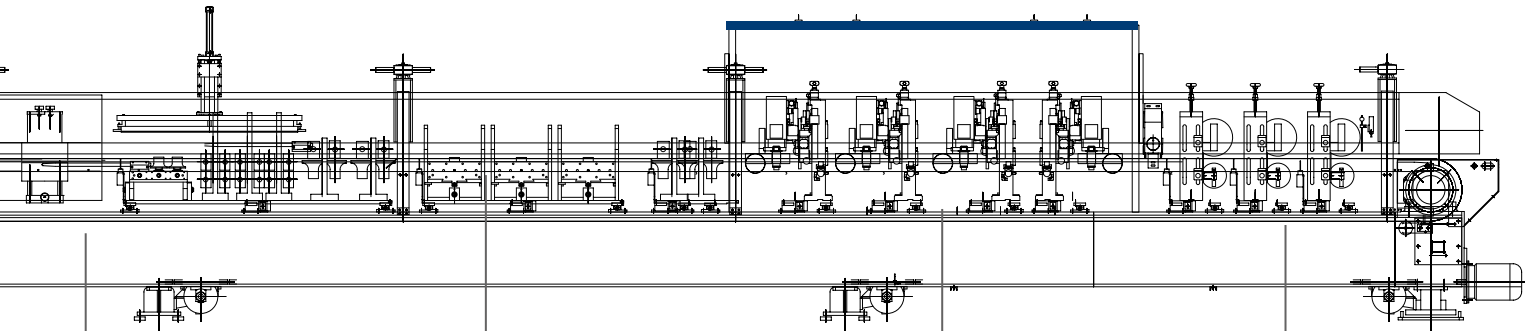

Lampara de calentamiento cola



Zona de envoltura laminado



Zona de acabado laminado



Zona de sellado de la unión

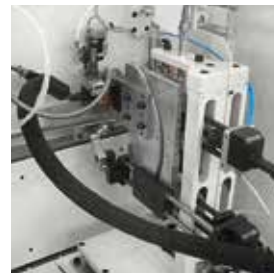



Tipos perfiles

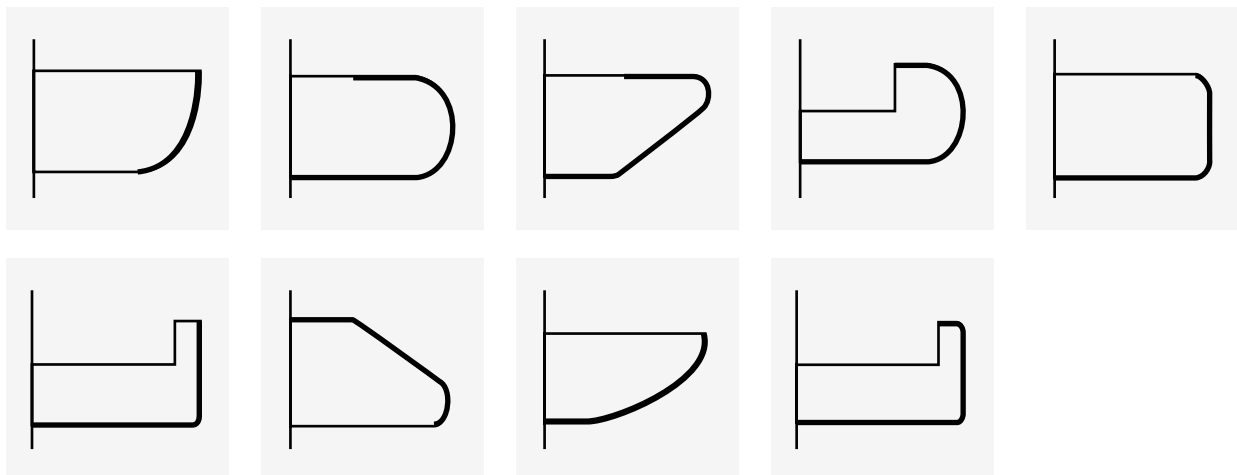

Datos técnicos

Espesor laminado max.	Rígidos: 0.8 mm	No rígidos: 1.5-2 mm
Espesor tablero max	Sin agregado: 45 mm	Con agregado: 80 mm
Ancho tablero min/max	120/1200 mm	
Velocidad de avance	20-25 m/min	
Desarrollo laminado desde hilo de trabajo max.	80 mm (opt 110 mm)	
Productividad	De 500 a 2000 tableros/turno (en función de las dimensiones y peso del componente trabajado)	
Arquitectura	Carga manual/maquina integrable con cargas/descargas automáticas	



SCM GROUP SPA

Via del Lavoro, 1/3 - PO Box 168 - 36016 Thiene (VI) - Italy
tel. +39 0445 359511 - fax +39 0445 359599
stefani@scmgroup.com
www.scmwood.com



00L0380771F