

 **BIESSE**

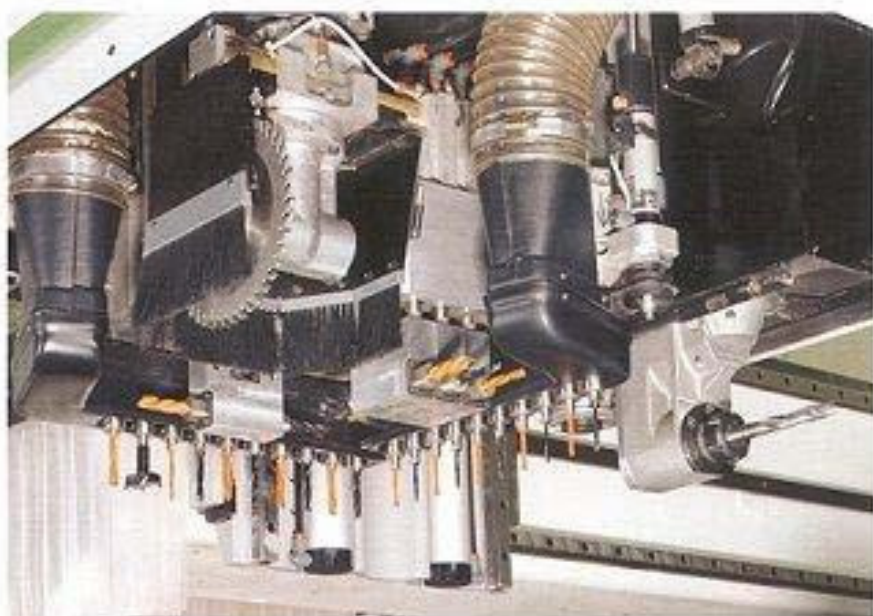

rover 30
series 2 & 3



Workings

BORING



- With its independent spindles, the Rover 30 can perform any vertical and horizontal boring program on five sides of the panel. The tool rotation speed of 4,000 rpm and the numerically-controlled adjustment of the feed speed offer an exclusive guarantee for perfect finishing of holes (standard).



GROOVING AND CUTTING

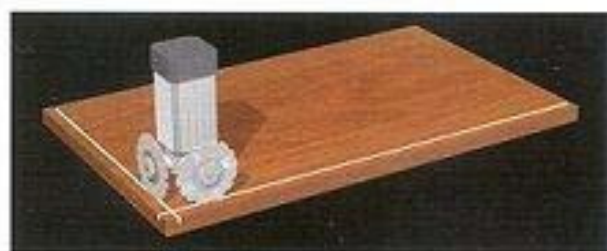
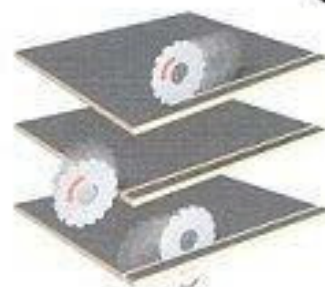

- The saw blade unit is fitted with a 5 HP motor featuring tool rotation speed up to 8,600 rpm. To execute cuts and grooves through the X and Y axes, the saw blade unit with NC automatic blade orientation at 0° and 90° can be mounted (optional).

Workings/Doors

ROUTING

Possibility of assembling electrospindles with different power ratings up to 10 kW (13.6 HP) and ISO 30, HSK F50 and HSK F63 couplings. The tool rotation speed continuously variable from 1000 to 24000 rpm allows the execution of all possible operations on any type of material.



■ Door profiling.



■ Mortising for key-lock.



■ Inclined boring for door hinges.



Work table



- Universal jigs with pneumatic unclamping and bar supports to facilitate movement of big and/or heavy panels (standard).



- Digital displays for work tables allow to view the positioning measures of all the panel supports and of all the jigs of the program to be executed (optional).

Work table



- Device with dual stop/clamp function for pneumatic clamping of narrow pieces (standard).

Automatic tool change

series 2

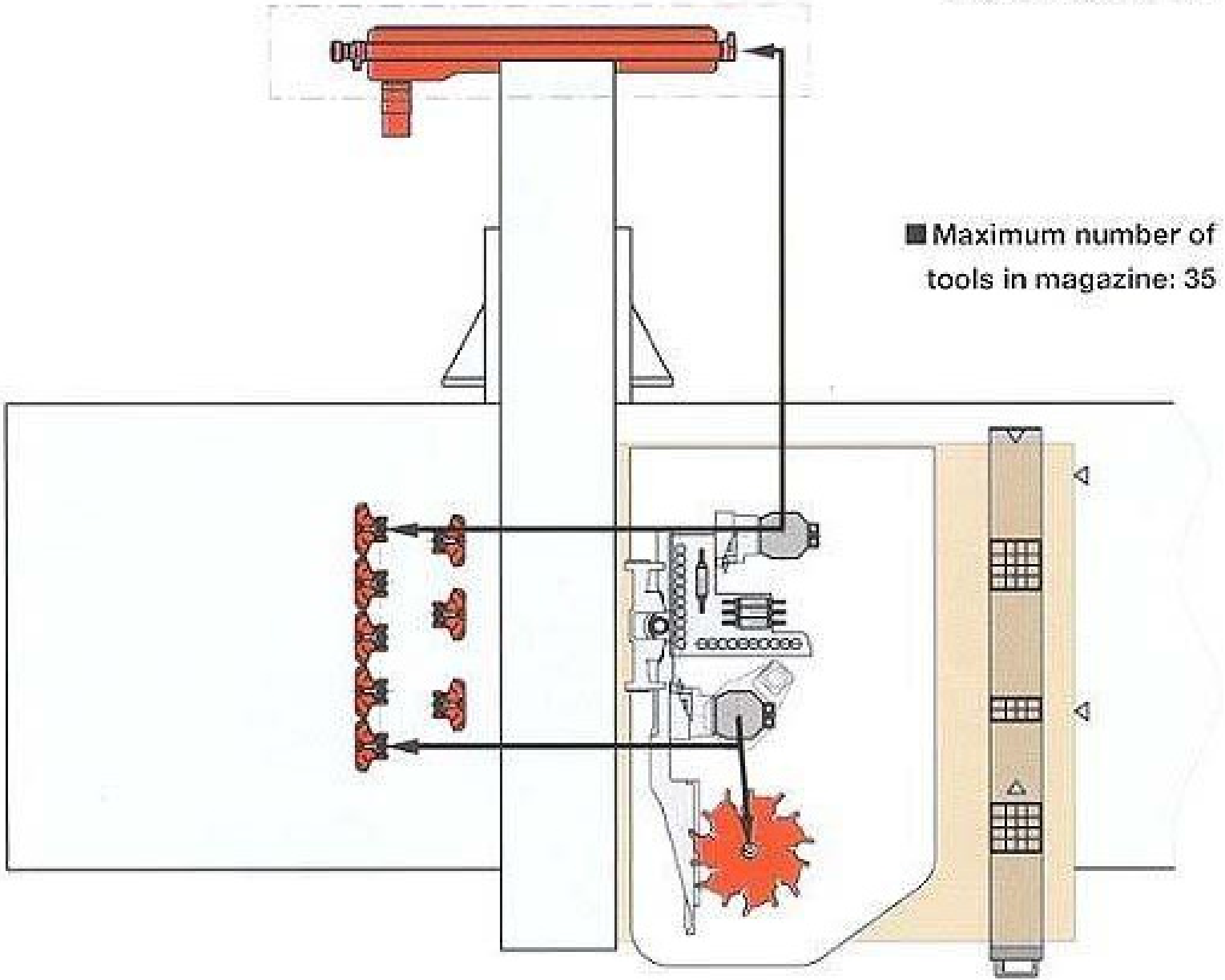

■ Maximum number of tools in magazine: 35

Automatic tool change



series 3

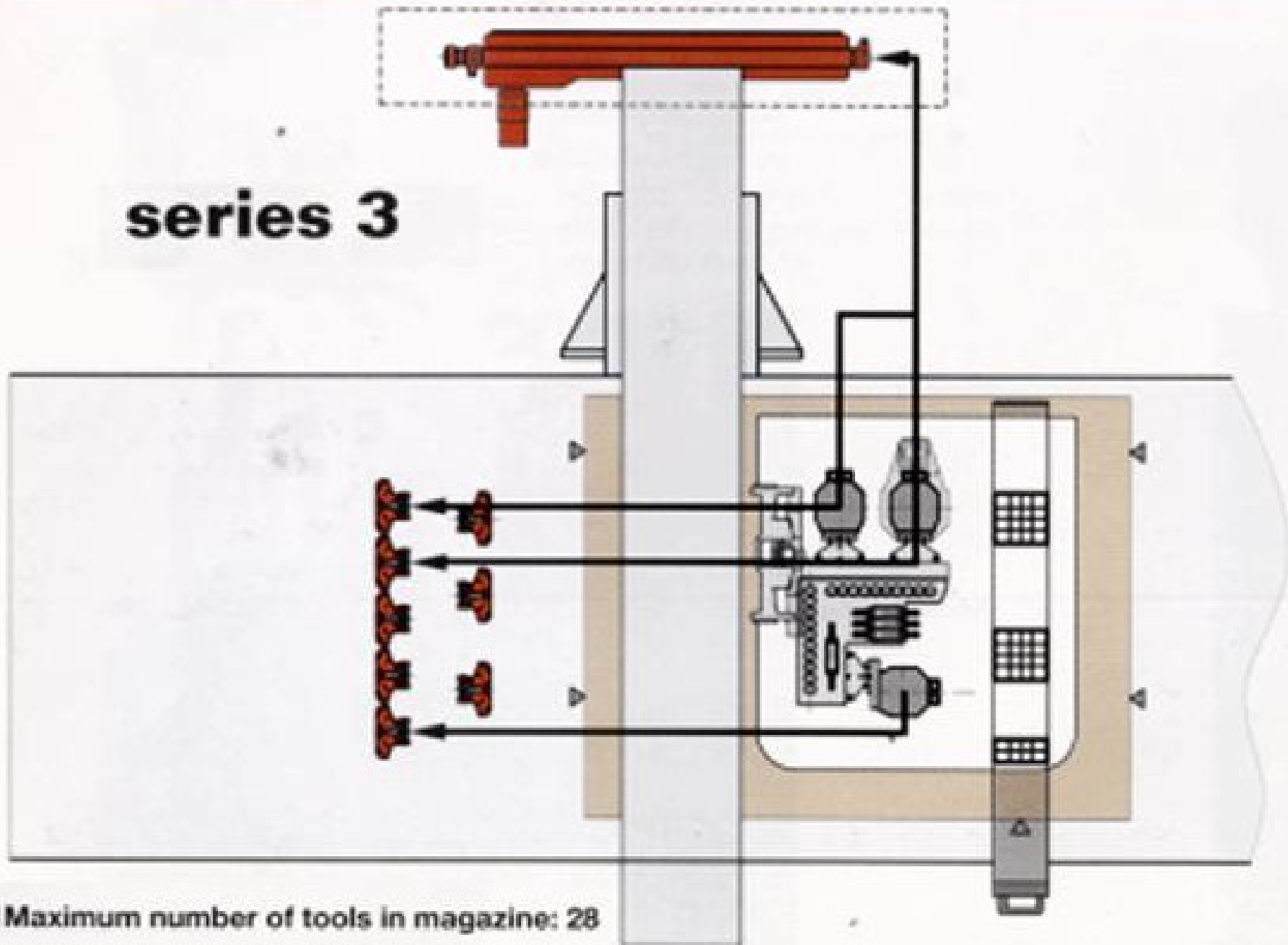

■ Maximum number of tools in magazine: 28

Aggregates



1 ■ ISO 30
HSK F50
HSK F63
max rpm 18000



5 ■ ISO 30 right or left rotation
HSK F50 right or left rotation
Max. rpm 12000



2 ■ ISO 30
HSK F50
HSK F63
max rpm 12000



6 ■ ISO 30 120 / 180 / 250 mm diameter
HSK F50 180 mm diameter
HSK F63 180 / 250 mm diameter
Max. rpm 12000 (depending on the tool diameter)



3 ■ ISO 30 / collet / flange
HSK F50 / collet / flange
HSK F63 / collet / flange
max rpm 12000



7 ■ ISO 30
HSK F50
max rpm 6000



4 ■ ISO 30
HSK F50
HSK F63
max rpm 18000



8 ■ ISO 30
HSK F50
max rpm 6000



■ XNC Numerical Control with extractable standard PC keyboard and IP65 industrial keyboard with mouse incorporated.

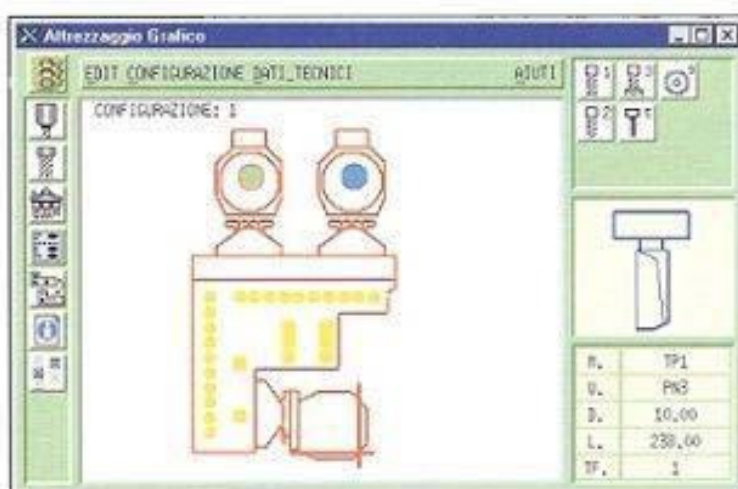

■ Graphic tooling.

The XNC Numerical Control runs on a PC platform and uses a real-time multitasking operating system capable of controlling several processes simultaneously, such as programming while the machine is working. The X-Windows graphic interface allows easy and intuitive use of the Numerical Control, since all the available functions are clearly recognisable through functional icons. The XNC Numerical Control also allows dynamic display of tool routes while machining is taking place, and automatically shows error messages on the screen, giving the possibility of consulting the "On-Line Instruction Manual" directly on the page concerning the message displayed.

Technical information

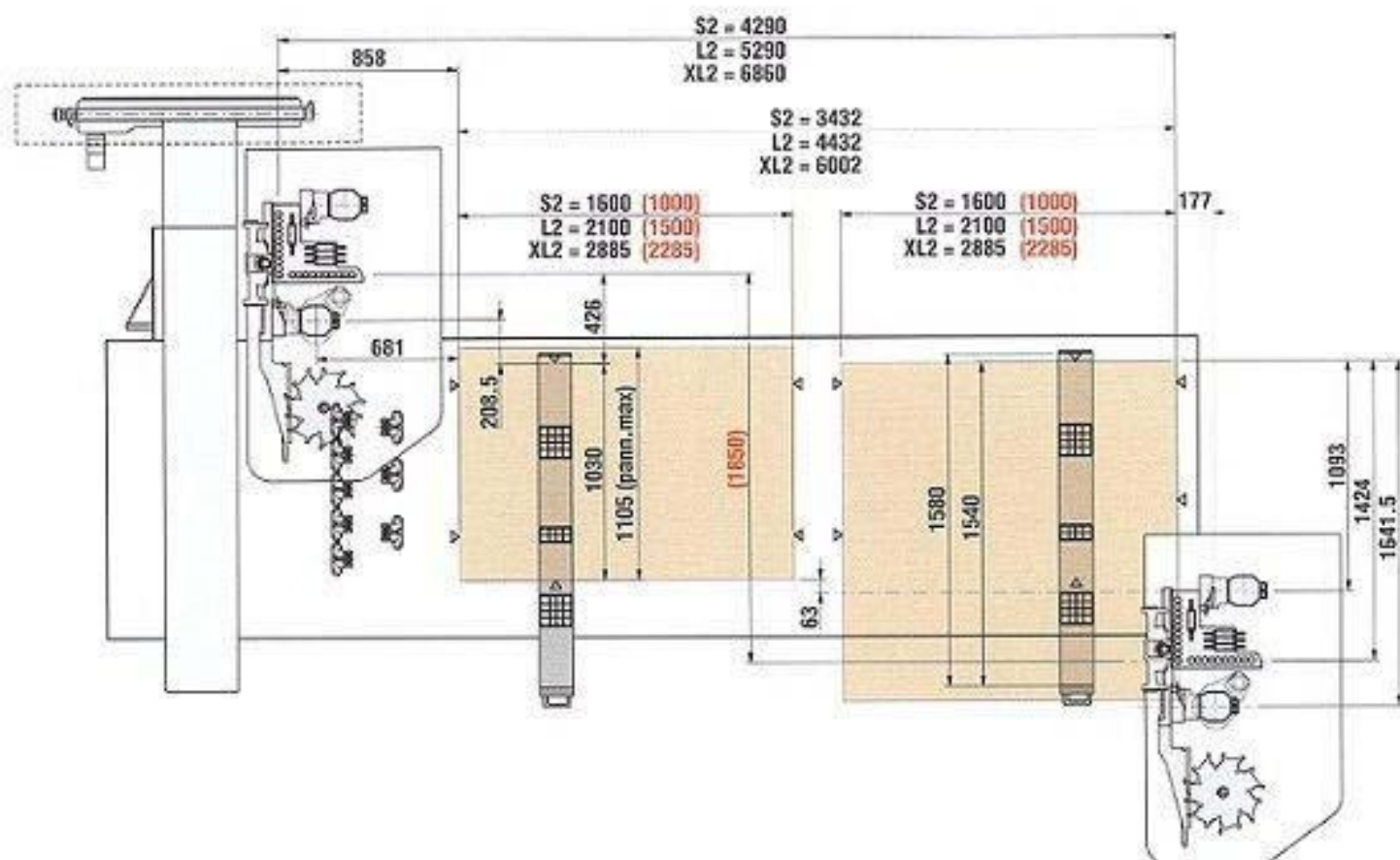

Working field.

() Norme CE

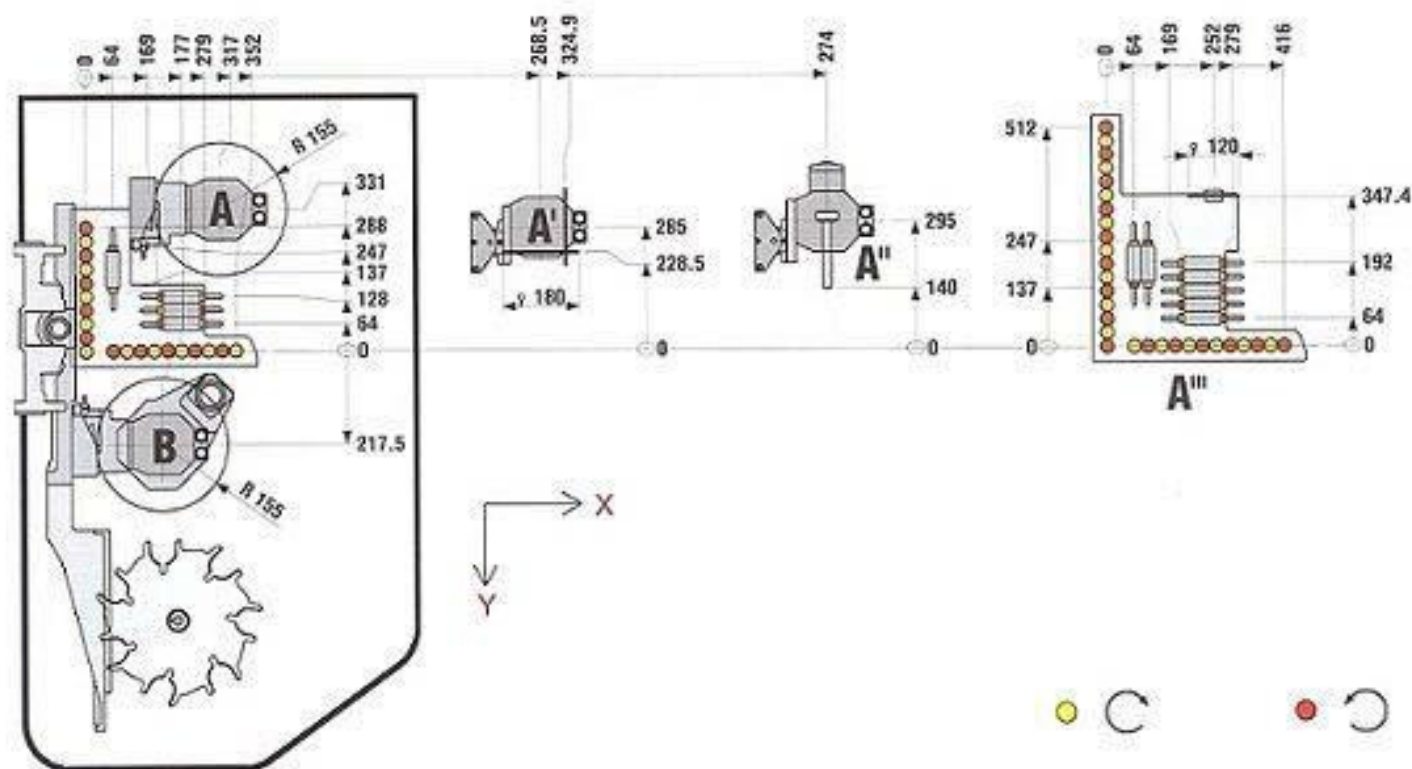

Operating unit layout.

A. Electrospindle (optional).

A'. Horizontal router (optional).

B. Electrospindle (standard).
C-axis (optional).

A'. Disk cutter, 180 mm diameter,
0° - 90° (optional).

A''. 43-spindle boring head.

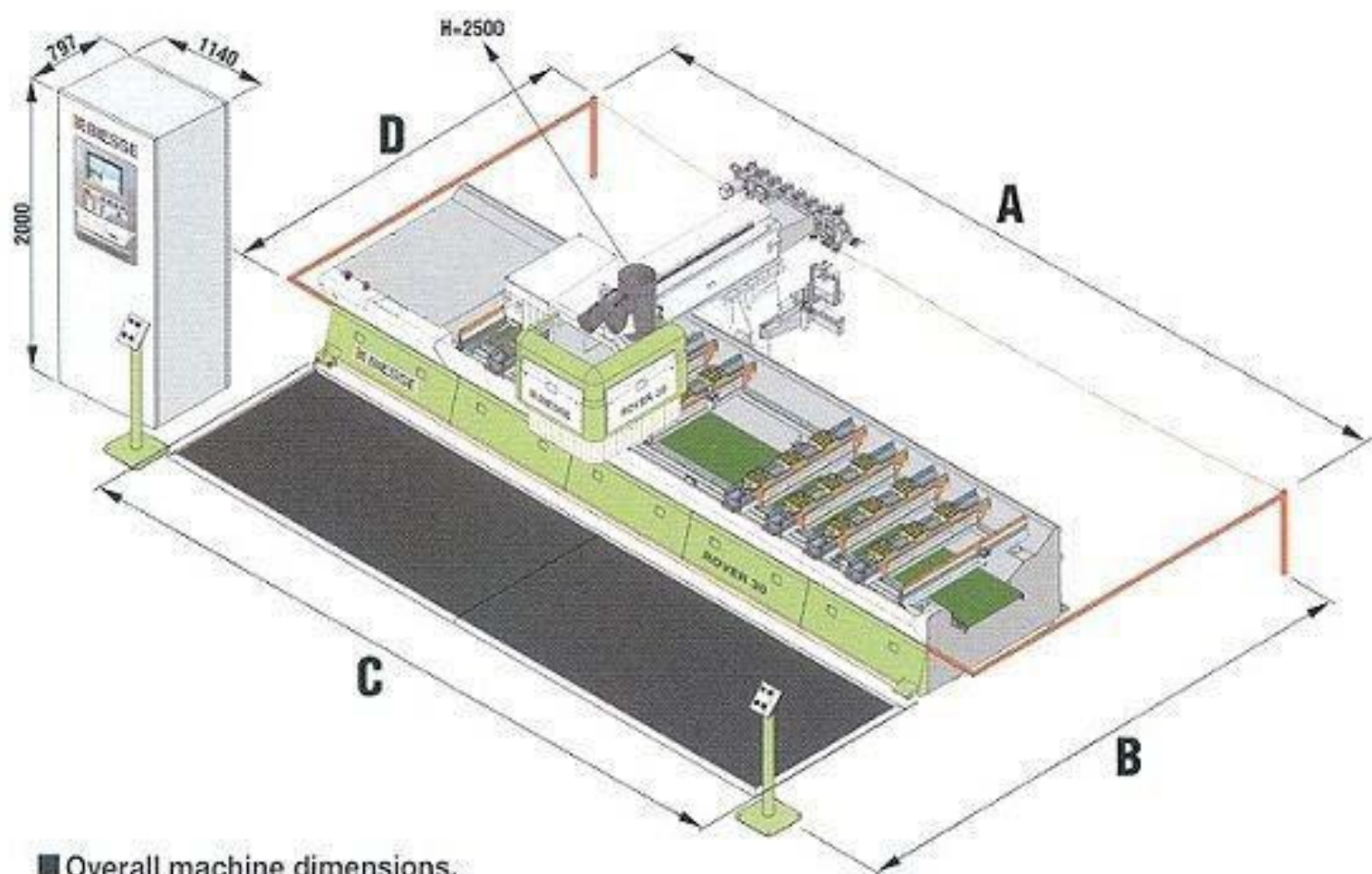

■ Overall machine dimensions.

	A mm	B mm	C mm	D mm
S2	6.960	4.300	6.260	2.750
L2	8.010	4.300	7.310	2.750
XL2	9.620	4.300	8.920	2.750
S3	6.960	4.300	6.260	2.750
L3	8.010	4.300	7.310	2.750
XL3	9.620	4.300	8.920	2.750