

SWT 200 Wide-Belt Sanding Machines





SWT 2000



Discover the possibilities. The HOMAG **SWT 200**.

For almost 70 years HOMAG has stood for high performance wide-belt sanding machines and innovative surface finishing. These include special and multi-purpose sanding machines for calibrating and intermediate sanding as well as lacquer finishing machines. Always focussed on the machining of wood and wood-based composite materials.

As versatile as our customers...

HOMAG is on the spot and active worldwide. Whether you are looking for good advice, sales or fast on-site service, you will find competent partners in over 65 countries representing the HOMAG brand.

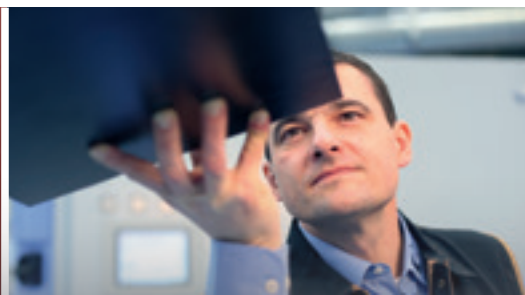

The SWT 200

The HOMAG SWT 200 series is every bit as diverse as our customers and we have ensured that each model remains a specialist in its field. On the basis of extensive experience and professional know-how, the available head combinations are adjusted to your conditions and tasks. Learn more about our performance packages with an optimal price-performance ratio.



Character

Putting on the right pressure...

According to requirements there are acp[®] and eps[®] sanding pads available – on your choice

Being adaptable...

Variable feed speed by frequency convertor (3 - 15 m/min.)

Being powerful...

Contact roller heads with up to 18.5 kW (option) strong motors and pad sanding head with 15 kW driving capacity with efficient Poly-V-belt drive.

Being efficient...

Independently driven sanding heads for high machining quality

Being stable...

Solid and very rigid design in new frame construction

Keeping it clean...

Integrated sanding belt blow-off device for increased sanding belt life time (option)

Saving space...

Minimal installation place at 1350 mm working width

Simplifying...

Workpiece thickness measuring – automatic measurement and thickness set up



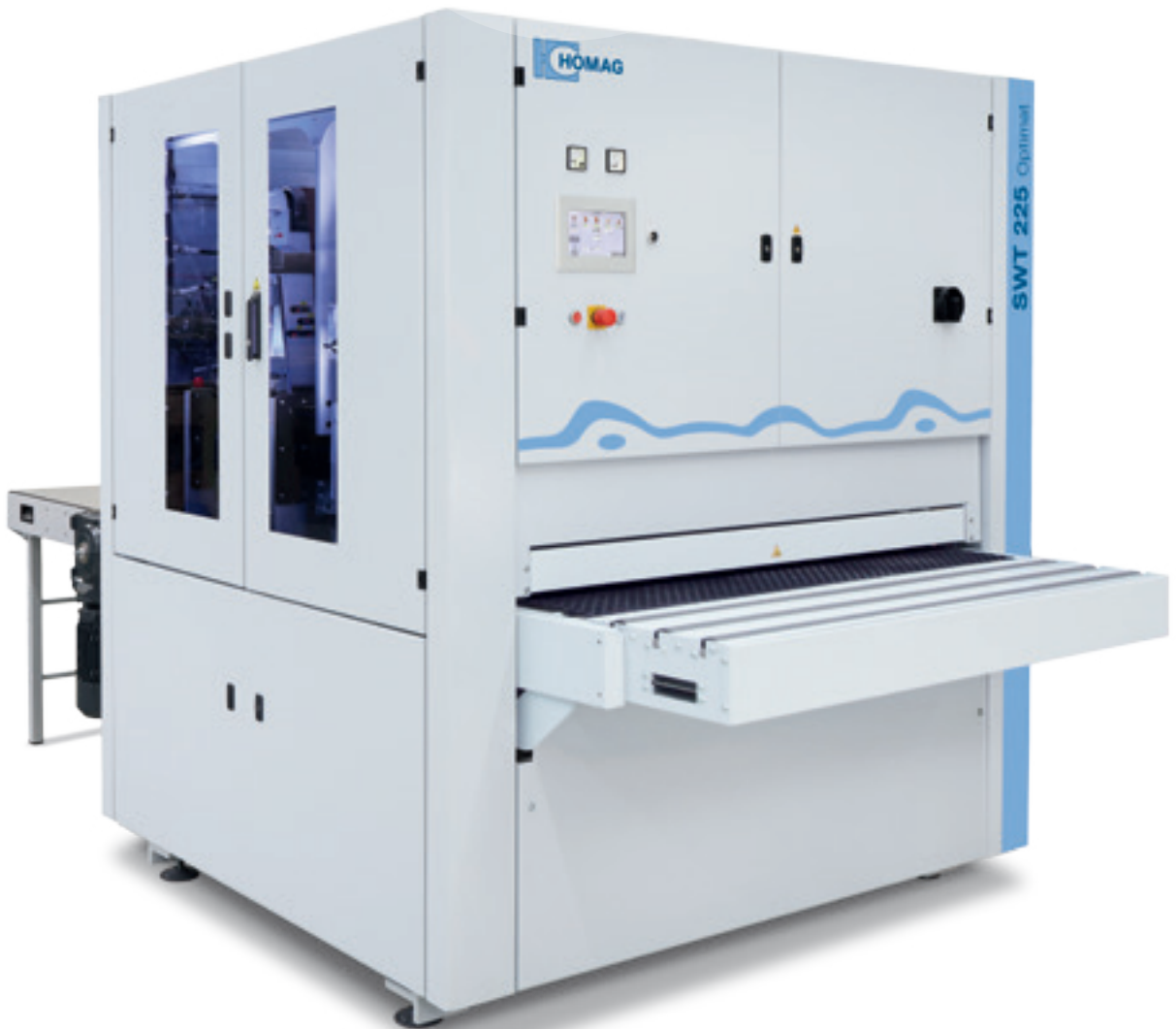

Pictures may show special equipment.

The SWT 200 series

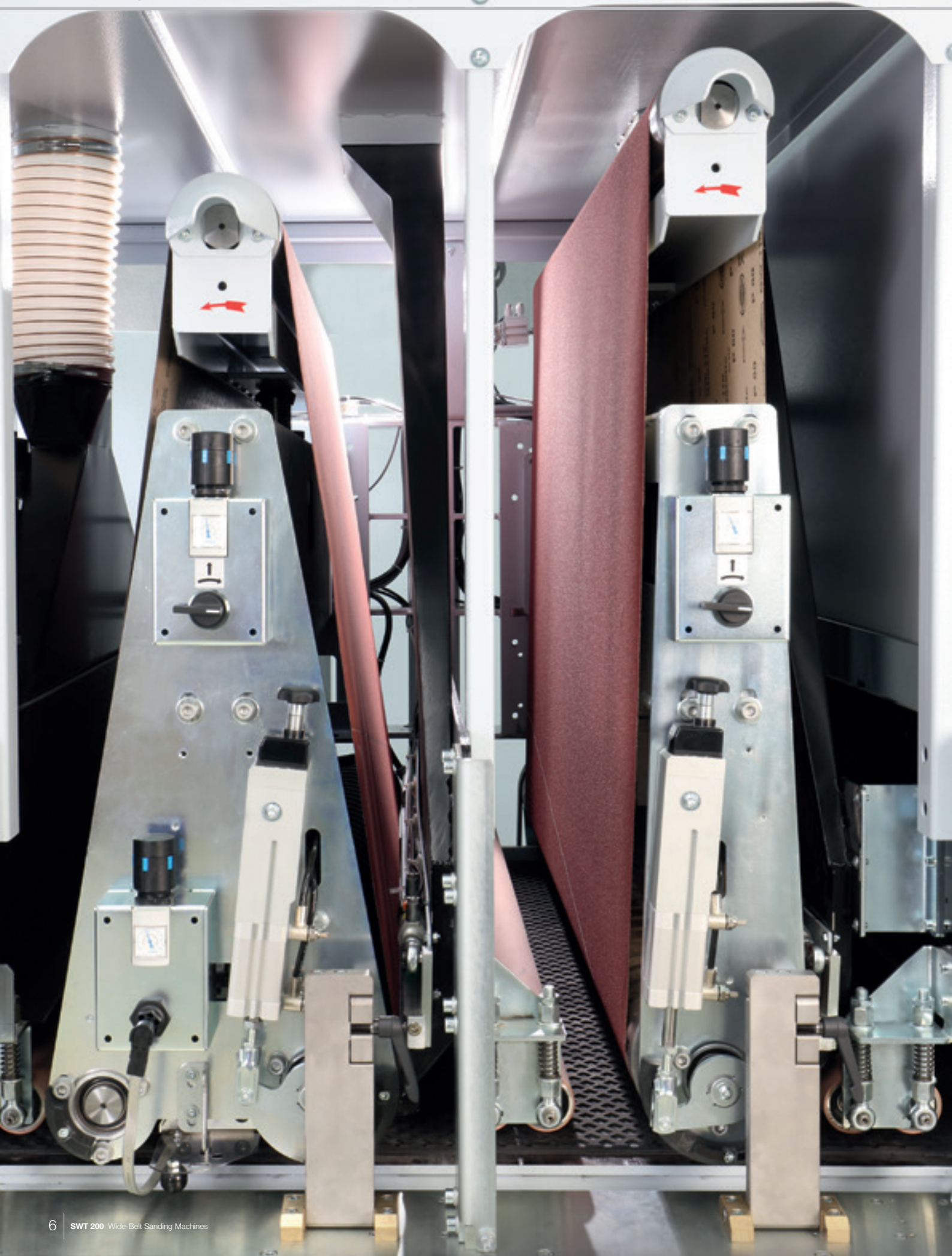

Do it your own way...!

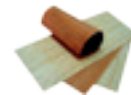















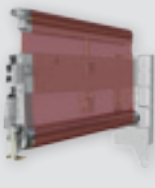







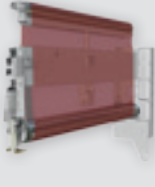

System



Solid wood

Veneer



Lacquer

SWT 215 L  		acp® 			
SWT 215 C  		eps® 			
SWT 225 RL   	 	acp® 	 		
SWT 225 RC   	 	eps® 	 		
SWT 225 RH   	 	eps® 	 		 
SWT 225 CC   	 	eps® 	 	 	
SWT 225 CH   	 	eps® 	 	 	 

As standard:

-  Well suited
-  Very well suited

Available as option:

-  Well suited
-  Very well suited

eps - electronic pressure system
 acp - air cushion pad

R

R-Head | Dimensional accuracy with tight tolerances

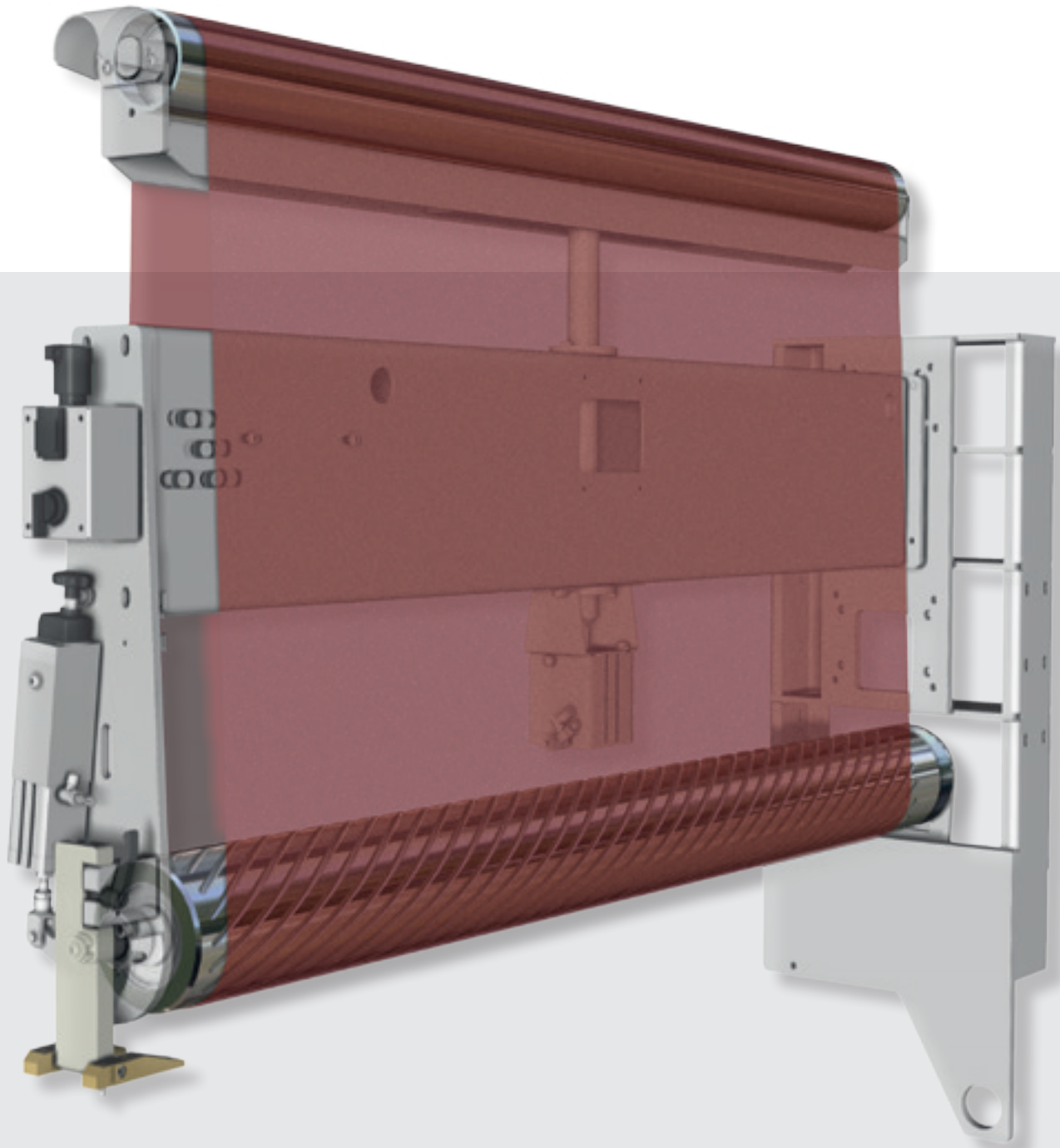



You often process solid wood and wish to calibrate over the entire width with high stock removal rates? Then you are here at the right address.

R- Head:

- The head for calibration and roughening of surfaces.
- The R-head allows precise calibration with high stock removal rates. Very efficient: the maintenance-free profiled contact roller. It avoids the so-called “wash-out effect” – possible when sanding wood with large density differences (summer resp. late wood).

Applications:

- Calibration of solid wood and wooden materials
- Roughening of surfaces suitable as mechanical key for glueing

Range of useful grit sizes:

- Calibration: P60 - P120



L/C

**L- and C-head |
The 2 in 1 head**

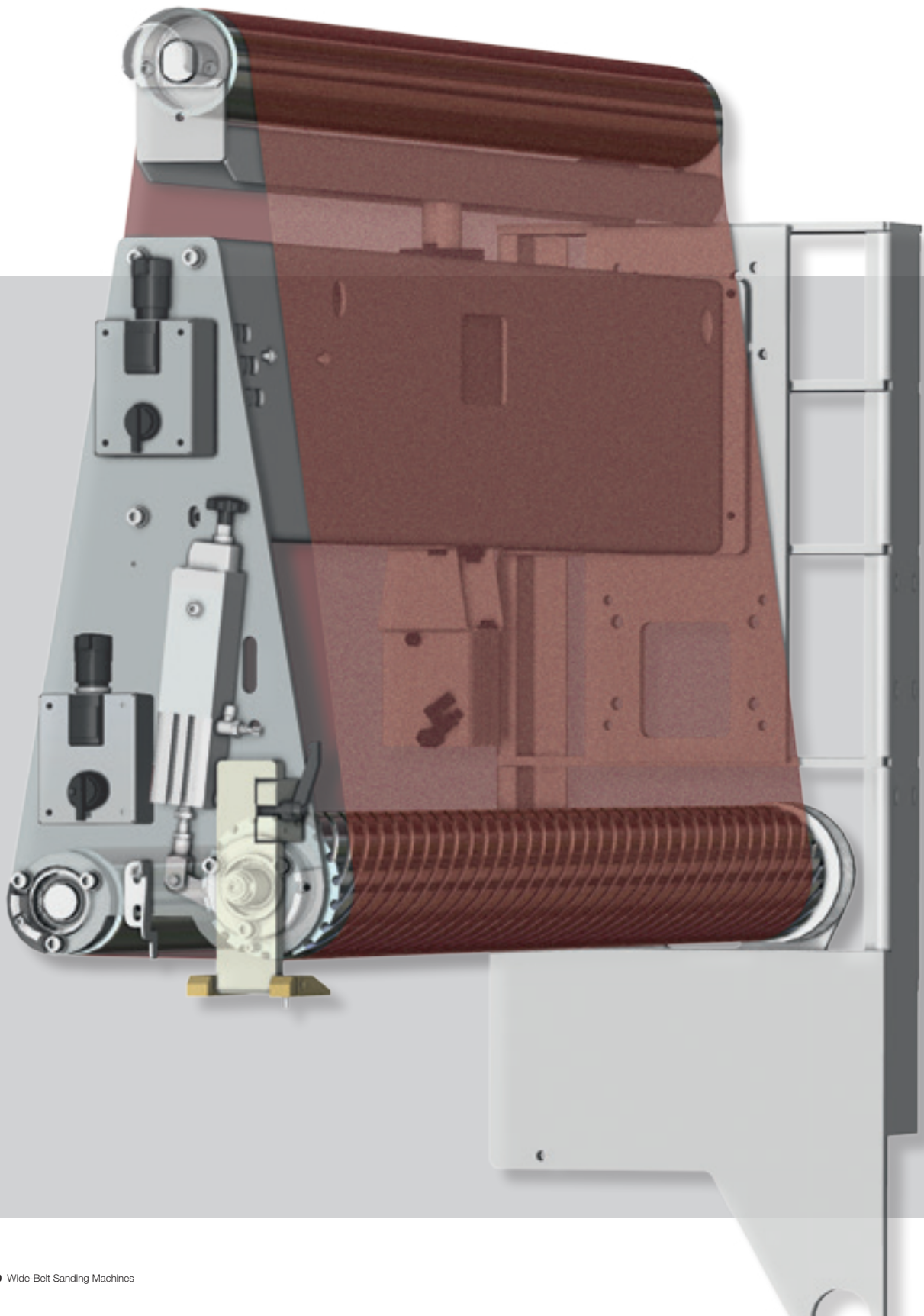



You require calibration and fine sanding? And all that in the smallest space? Then you are here at the right address.

L- Head:

- Combined head with profiled contact roller and acp[®]-system.
- The use of the contact roller in the L-Head allows precise calibration without “wash-out effect”.
- By using the pneumatic pressure pad with the acp[®]-system the correct sanding pressure is guaranteed over the complete working width and ensures continuous surface quality.

Applications:

- Calibration and fine sanding of solid wood and wooden materials

Range of useful grit sizes:

- Calibration: P60 - P120
- Fine sanding: P120 - P220

C- Head:

- Combined head with profiled contact roller and eps[®]-system.
- The use of the contact roller in the C-Head allows precise calibration without “wash-out effect”.
- By using the electronically controlled segmented pad with eps[®]-system thickness tolerances of veneered and lacquered workpieces of up to 2 mm are compensated.

Applications:

- Veneer sanding
- Calibration, intermediate and fine sanding of solid wood, wooden materials and lacquered surfaces (Option)

Range of useful grit sizes:

- Calibration: P60 - P120
- Fine sanding: P120 - P400

acp[®]



eps[®]



H

H-Head | Perfect fine sanding

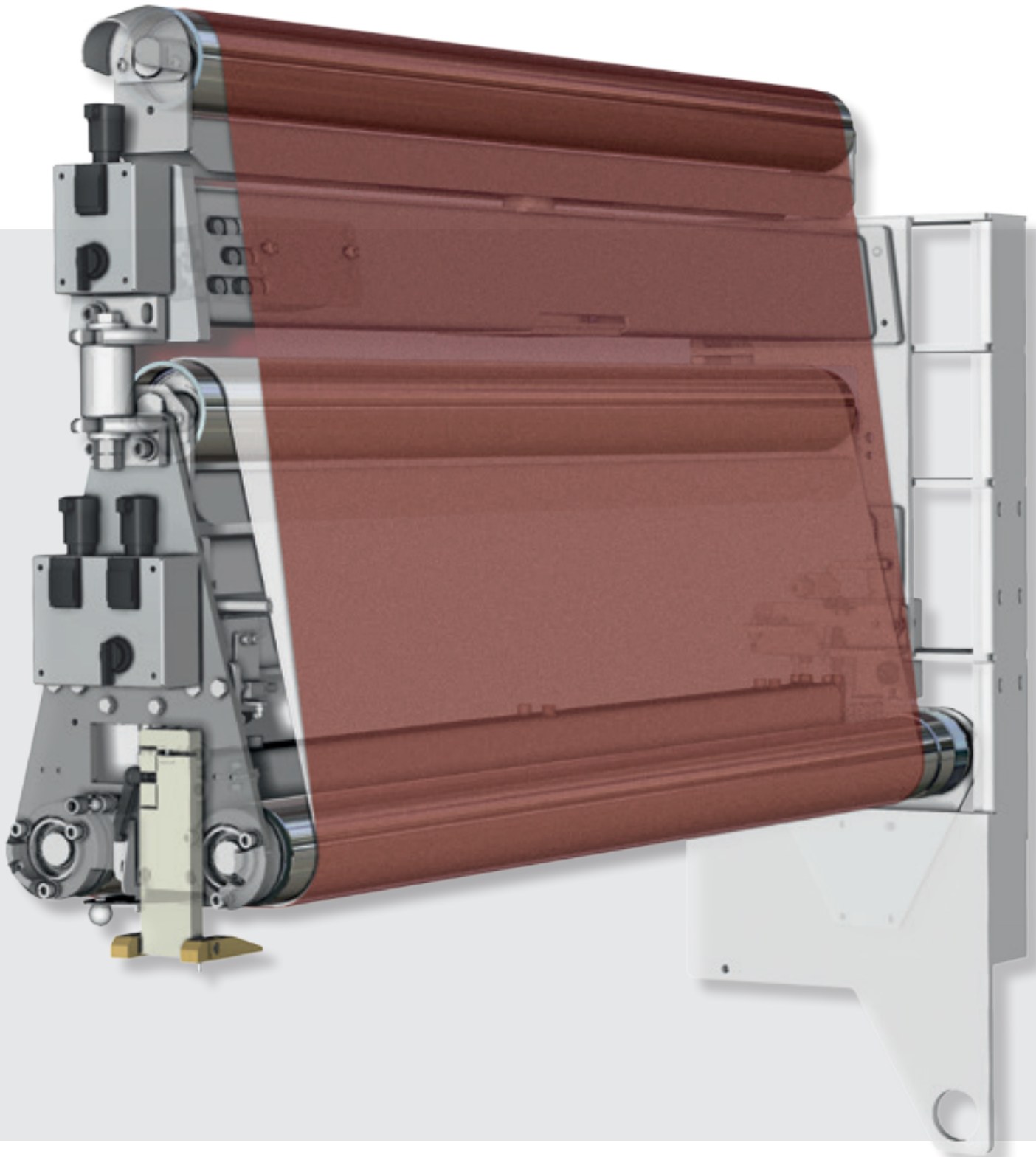



High-quality surfaces are important for you? Then you are here at the right address. This head is most suitable for veneer, lacquer and filler sanding.

H- Head:

- By using the pressure pad with eps system thickness tolerances of up to 2 mm are compensated.
- Adapts to most applications thanks to variable cutting speed (option)
- No 'sand throughs' on the surface or at edges.
- Especially the Chevron belt provides a homogeneous and quiet surface. No oscillation marks. Lower sanding temperatures increase the sanding belt lifetime.

Applications:

- High-quality sanding of different surfaces
- Intermediate lacquer and filler sanding as well as very fine grit sizes
- Solid wood sanding, especially for frame parts

Range of useful grit sizes:

- High gloss preparation sanding up to P1200 grit



Control side SWT 200

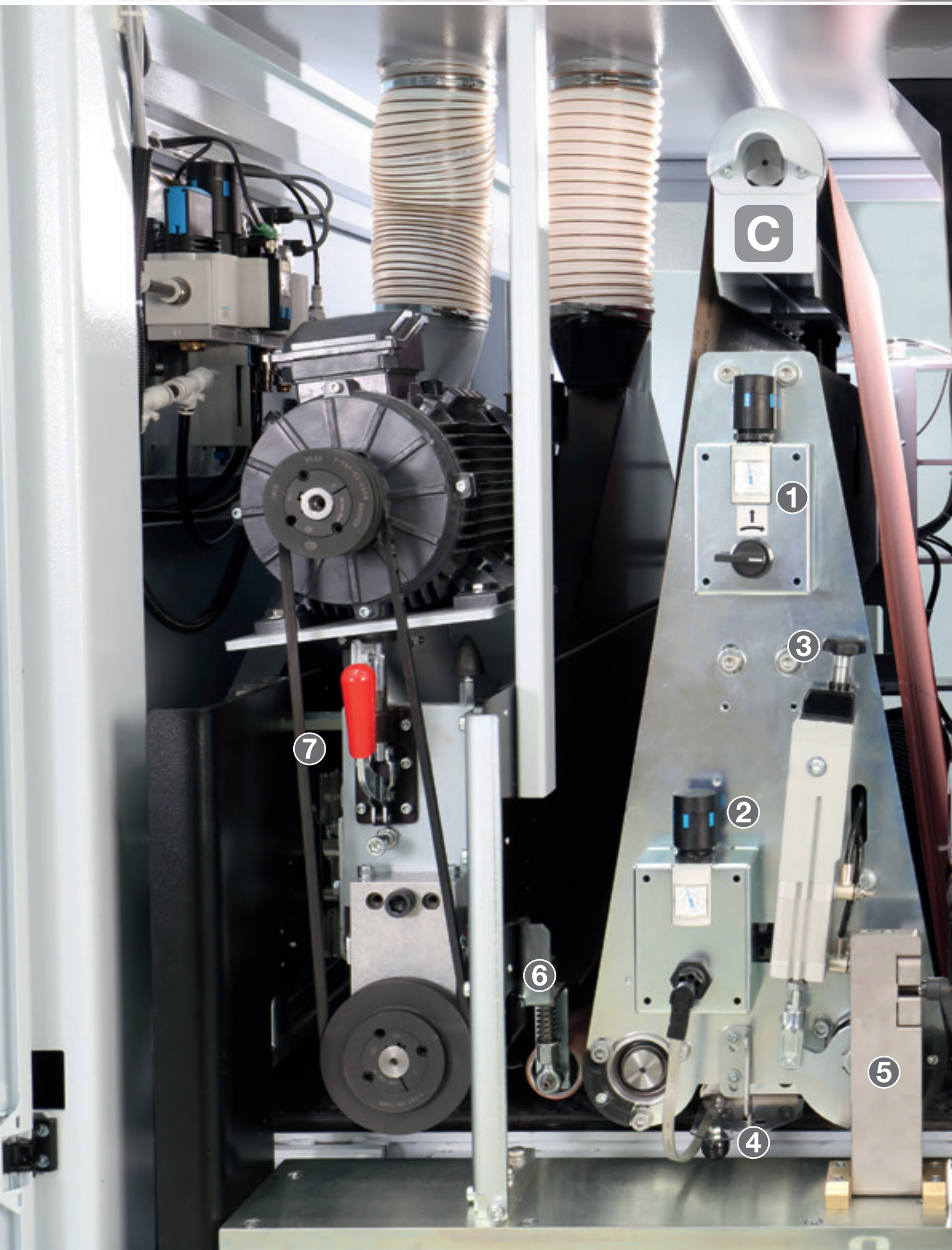

C

1

3

2

7

6

5

4

Everything under control with the operating concept of the SWT 200

- 1 Belt tension
- 2 Sanding pressure regulation
- 3 Compensation of grit sizes with hand wheel for precise calibration
- 4 Earthed sanding tongue
- 5 Safe and solid head quick lock
- 6 Spring-loaded and rubberised pressure rollers
- 7 Simple quick-change device for brushes



**For the right pressure at the right place
at the right time**

acp®



The air cushion sanding pad

Efficient and precise sanding...

The acp® system senses incoming workpieces and activates the rise and fall pad system to give an anti-dubbing facility at both leading and trailing edges of the part.

Highlights:

- Pneumatic pressure pad system for the right pressure over the entire working width
- Adjustable sanding pressure for consistent surface quality
- Optimal for processing solid wood

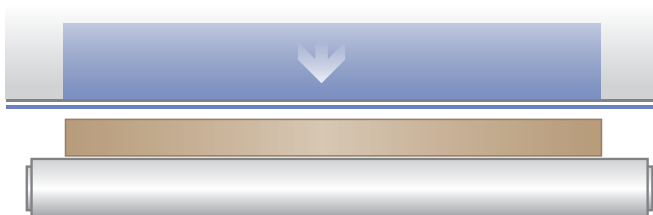



The electronic pneumatic system

Optimal pressure due to small segment width of 50 / 25 mm

The machine's electronics ensure the optimum sanding pressure on all areas of a workpiece, guaranteeing a perfect sanding result.

Highlights:

- Electronically controlled segmented pad system for efficient sanding pressure
- 50 / 25 mm segment width for perfect sanding results on all areas of the workpiece – even with parallel feeding of parts
- Automatic adjustment of the segments to the workpiece surface
- Thickness tolerance compensation up to 2mm.

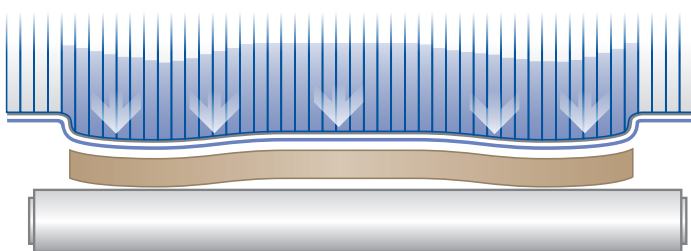

Pressure and compensation behaviour of the individual segments for warped workpieces or workpieces with thickness tolerances. Within the tolerance range of max. 2 mm the same pressure is applied to different areas of the workpieces.

All inclusive

With the SWT 200 you are provided with top-quality equipment from the very beginning. By including elementary technologies already in the standard, highest processing quality is ensured in the long term.

Touchscreen Operator Terminal

- 7" colour touchscreen for complete machine control
- User-friendly graphic interface
- Programme backup via USB stick possible

Workpiece thickness setting

- Workpiece thickness range by four threaded spindles (diameter 36 mm) adjusting the upper machine frame.



Workpiece thickness measuring

- Device for automatic thickness measurement
- Including automatic setting of the machine to the required workpiece thickness.

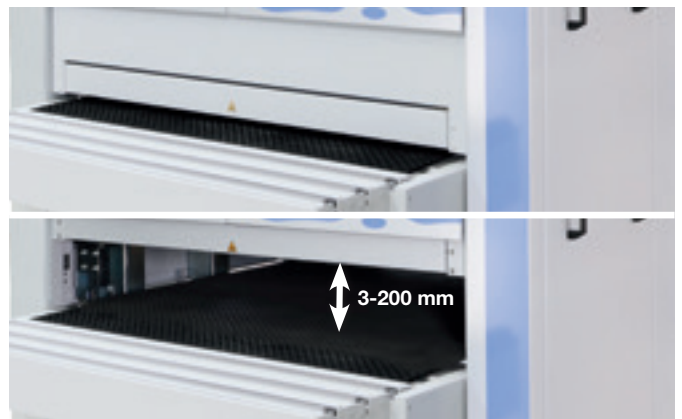
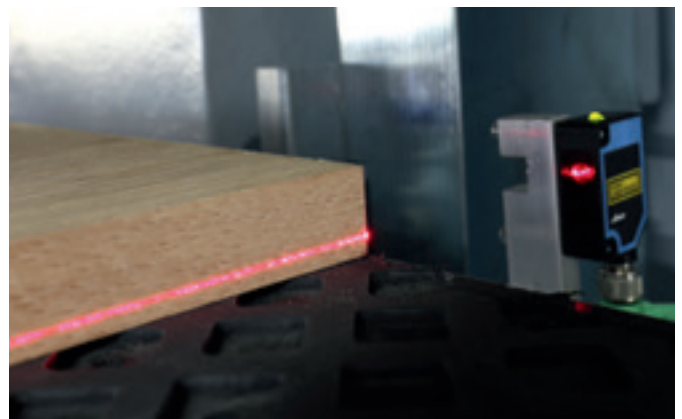

Workpiece thickness setting

- Thickness adjustment (3-200 mm) and constant working height (900 mm) by adjustment of the upper frame of the machine.



Feeding unit

- Variable feed speed by frequency convertor
- High quality multi-ply conveyor belt



Grit size compensation

- Very simple and precise grit size compensation by adjustment via hand wheel
- Dimensions for the grit size compensation are provided in the respective sanding programme

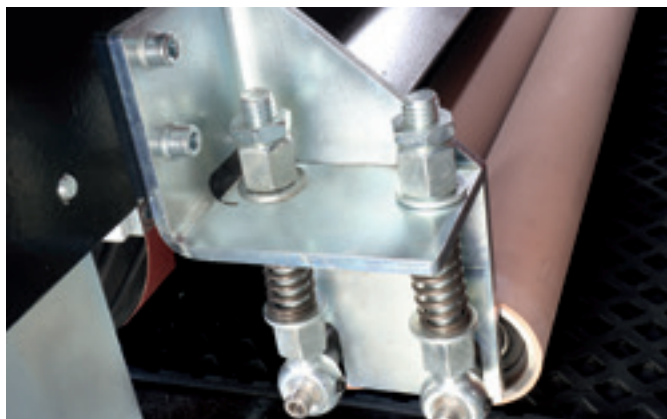

Part guidance by rubberised pressure rollers

- Spring-loaded rollers with guidance system
- Positioned close to sanding heads
- Pressure rollers in front of and behind workpiece sensing zone

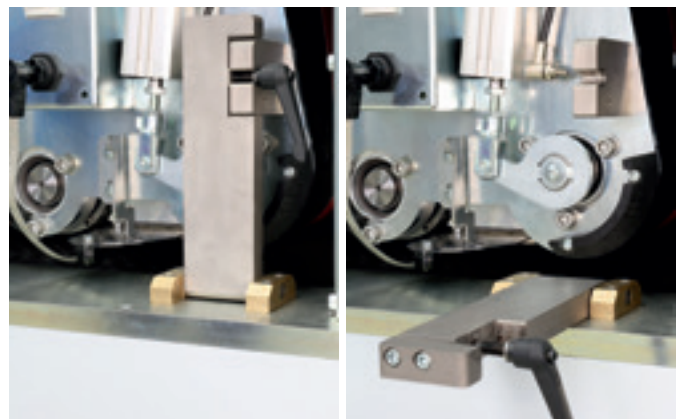

Head locking

- Safe and simple quick lock of heads and fast change of sanding belt

All inclusive



Segmented pressure pad system (C- and H-head)

- Optimal pressure due to small segment width of 50 / 25 mm (25 mm option)

Infeed rollers

- Easy workpiece handling
- Solid rubberised design



Earthing of sanding insert

- Earthing of the complete sanding insert to avoid electrostatic charge of workpiece and sanding belt



Lockable handle / machine window

- Safety handle for safe operation of the machine
- Large windows allow an easy control of the sanding process



Electronic abrasive belt oscillation

- The running of the sanding belt is controlled by large light sensors
- Thus, an extremely quiet oscillation is achieved



Optimal tracing

- Electronically controlled segmented pad system for efficient sanding pressure
- Automatic adjustment of the segments to the workpiece surface

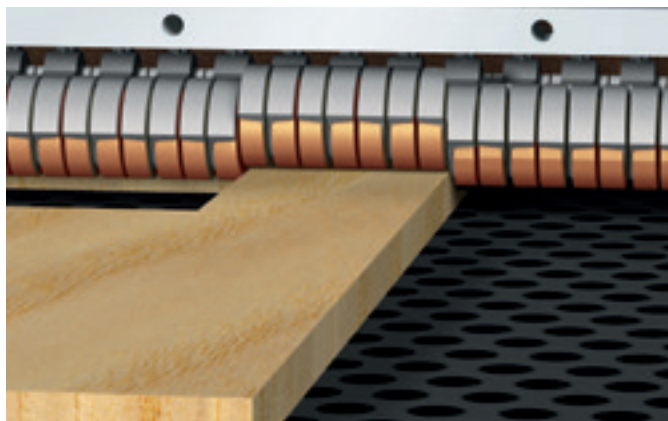

Solid machine frame

- Very rigid frame design with high running precision
- Good access e.g. for cleaning
- Increased safety by fixed machine hood



Simple installation of sanding belt

- Positioning units at the head provide an easy change of the sanding belt



ECO mode

- Automatic machine stop with advance warning function to save energy in case of unnecessary idling of the machine
- With frequency-controlled drives, decrease of the idle power by 50 % – as standard

Options

Would you like something extra? Our options provide all opportunities for perfect adjustment of your wide-belt sanding machine to your production.

Also available (not shown):

- Brush-changing carriage for comfortable brush change
- Frequency inverter for brush
- Rubberised contact rollers
- Roller table at outfeed

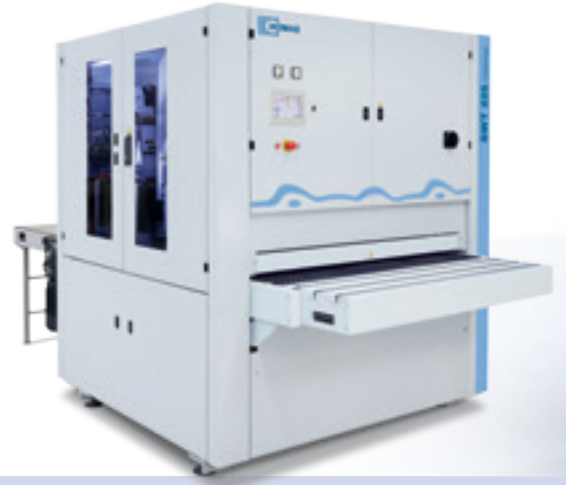

Air-jet belt blower

- Integrated air-jet belt blower
- Workpiece-controlled for low compressed air consumption

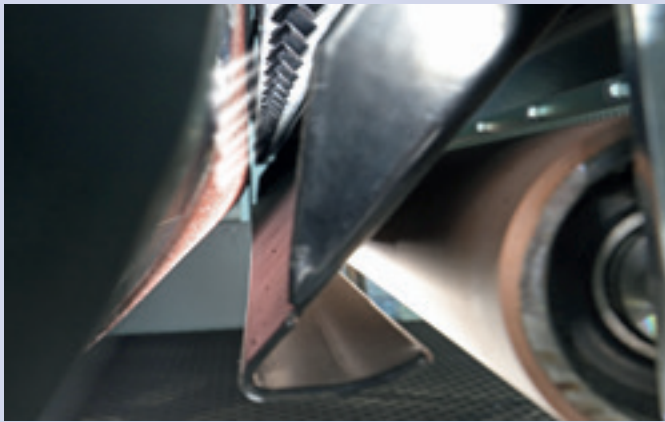

Variable cutting speed

- Speed control via frequency converter
- Power transmission via Poly-V-belts.



Vacuum clamping system

- For safe transport of small resp. lacquered workpieces
- Option 1: prepared
- Option 2: integrated
- Option 3: divided vacuum table, recommended for small workpieces



Lacquer sanding package for C and H heads

- Consisting of:
- Vacuum
 - Upgrade to segment width 25 mm
 - Integrated air-jet belt blower
 - Additional sanding insert



Air-conditioner

- Air-conditioning unit for switch cabinet for regions with high ambient temperatures

Driven finish brush

- For gentle cleaning of the workpiece surface with horse hair trim

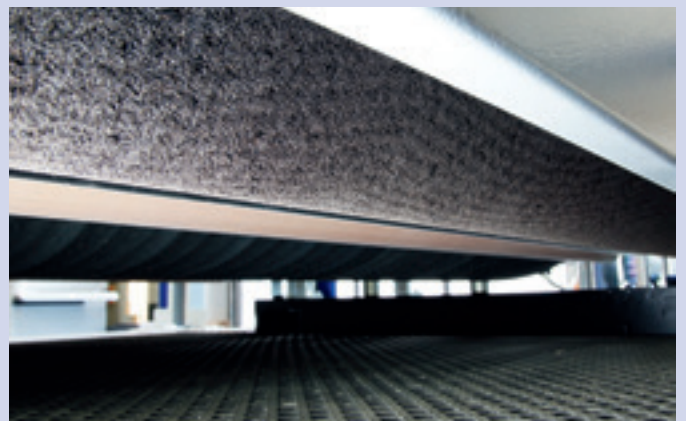

Fold-away outfeed table

- Solid retractable support table – a reasonable option with low space requirement



Workpiece cleaning rotors

- Workpiece cleaning system with rotating nozzles
- Ionisation unit to neutralise electrostatic charge for improved workpiece cleaning

Options



Brush with quick-change device

- Diameter 150 mm, main motor 5,5 kW
- Frequency regulation as option
- Different brushes available

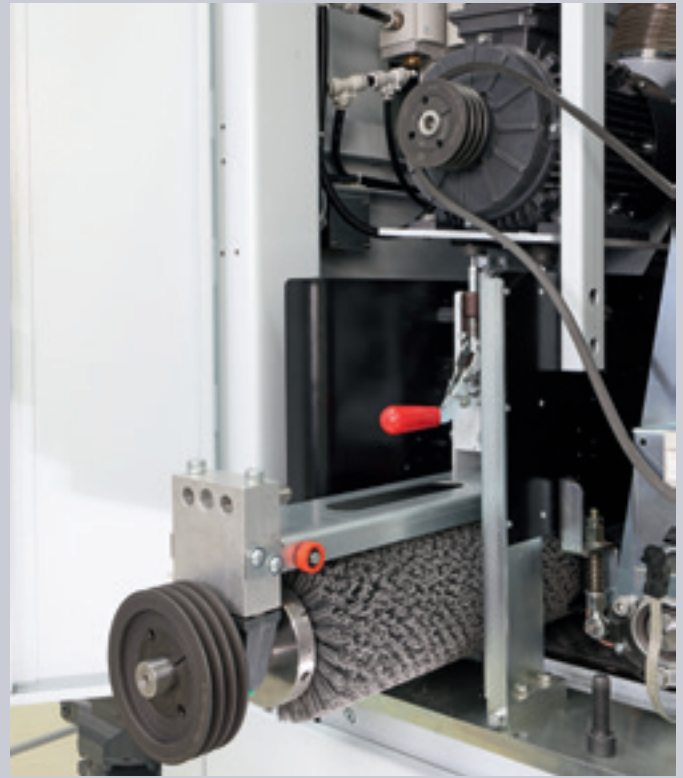

Structuring brush Anderlon

- Ideal for light to medium structuring of hard- and softwood



Structuring brush Stranded wire

- Well suited for intense structuring of hard- and softwood

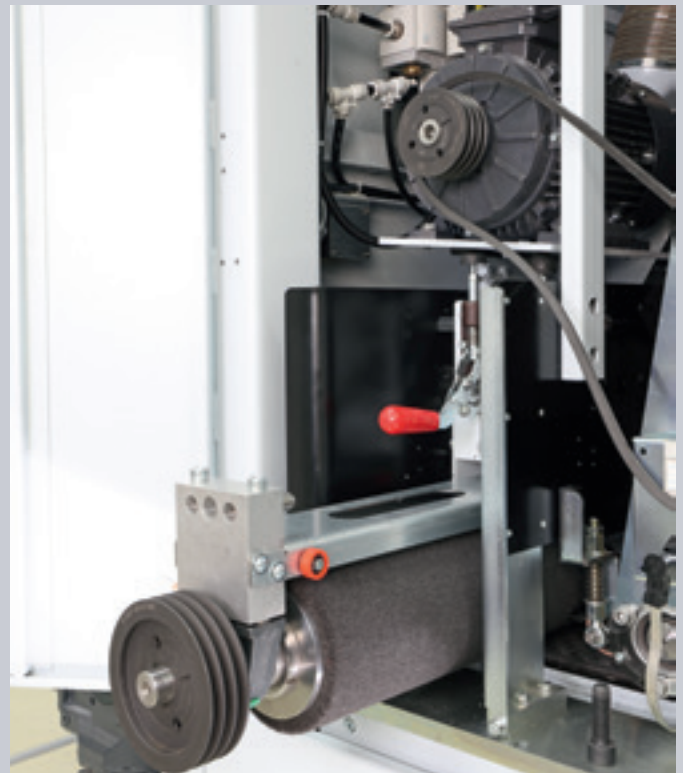

Glazing brush

- Recommended to smooth and to emphasize pores on lacquered surfaces



Drive side SWT 200

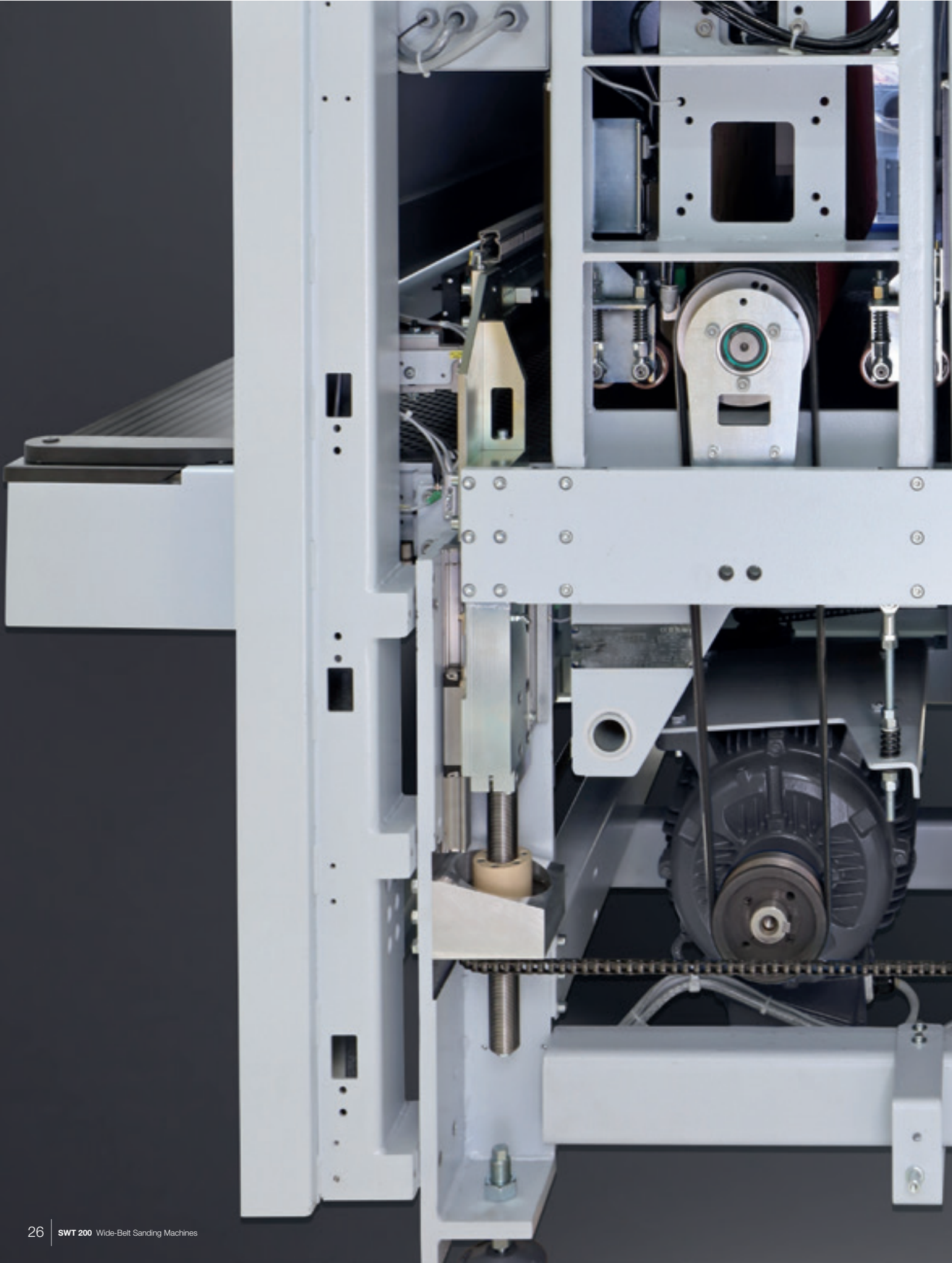

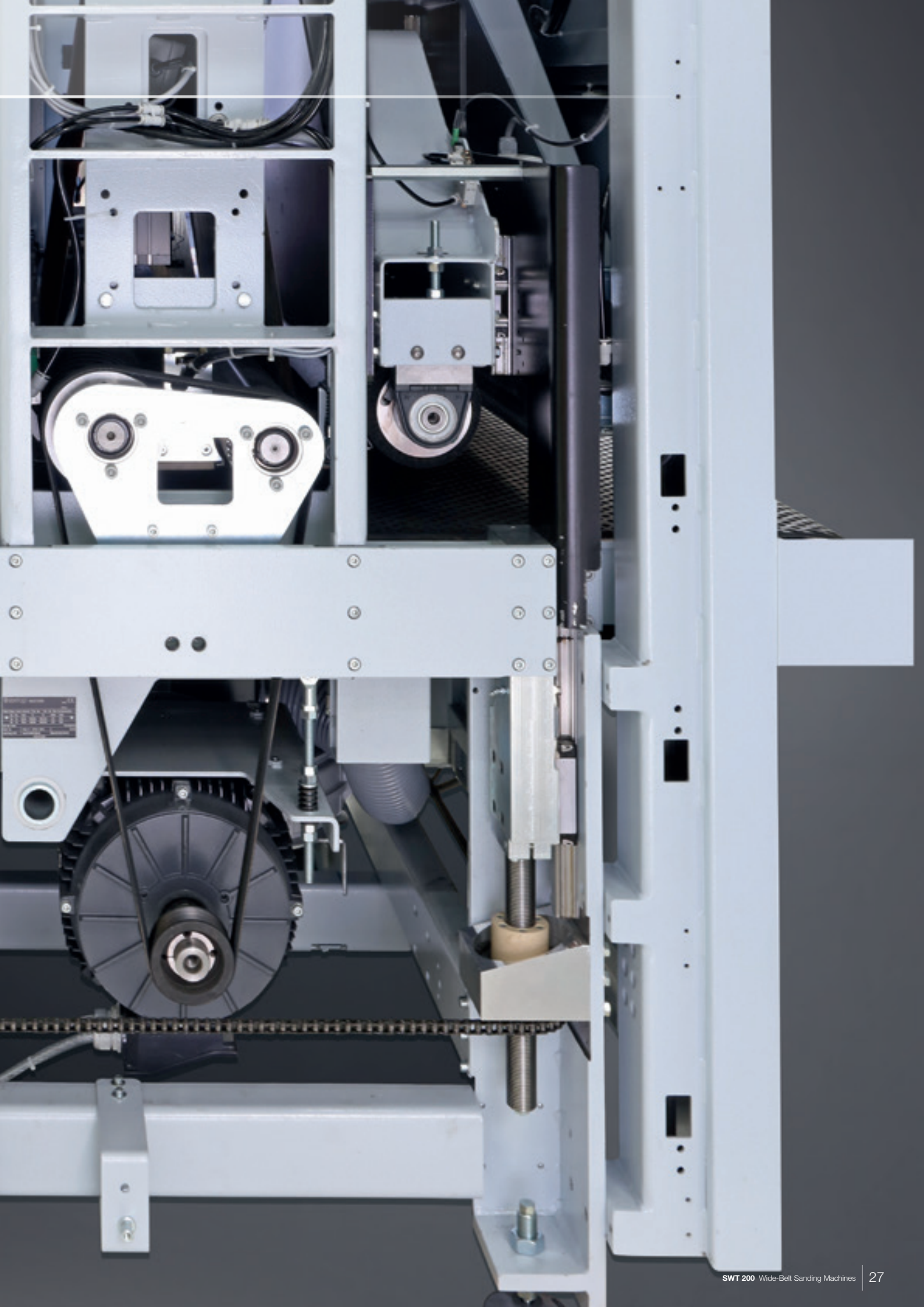

The technical data

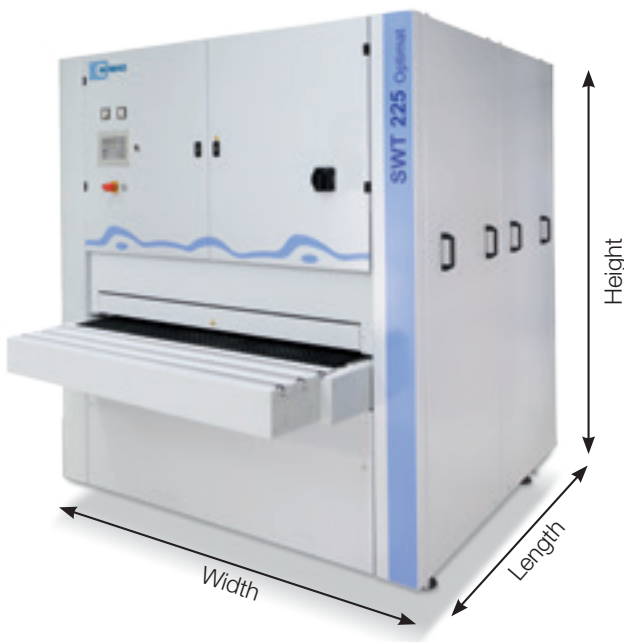

Model	SWT 215	SWT 225
Number of heads	1	2
Working width mm/inch	1350/53"	1350/53"
Width of sanding belt mm/inch	1370/54"	1370/54"
Length of sanding belt mm/inch	2150/85"	2150/85"
Workpiece thickness min. – max. mm	3-200 / 1/8" -8"	3-200 / 1/8" -8"
Air pressure bar / Compressed air usage max. l/min (without options)	6 / 20	6 / 40 6 / 60 (RH / CH)
Dust extraction ca. m3/h (without options)	1830	3660
Length / Width / Height mm	2390 / 1850 / 2100-2290	2390 / 1850 / 2100-2290
Total connected load kW (without options)	17	32
Weight approx. kg	3100	4000

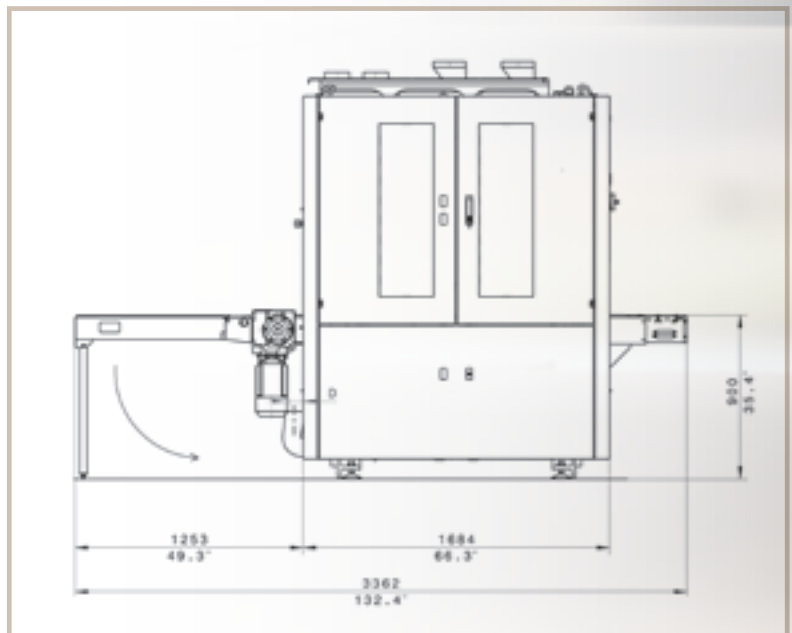
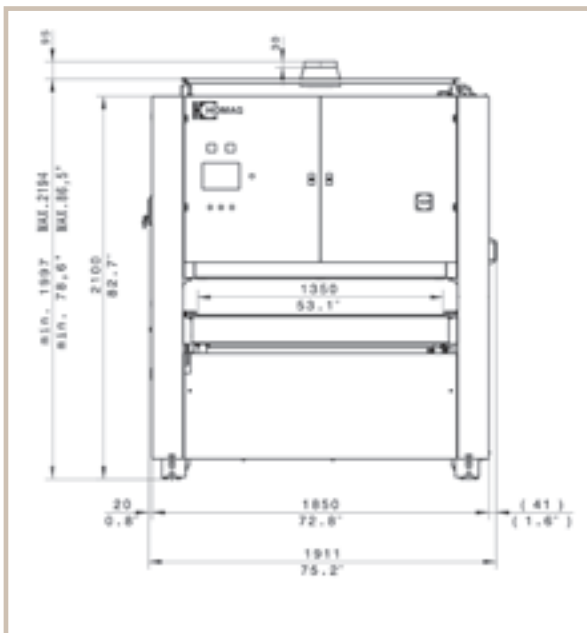

Installation drawing includes options

Focussing on the essential



HOMAG Group LifeCycleServices

The sale of our machines comes with all-in optimum service backup and individual advice.
We support you with service innovations and products which are optimally tailored to your requirements.
With short response times and fast customer solutions we guarantee consistently high availability and economical production – over the entire life cycle of your machine.



LifeCycleServices





HOMAG Finance – precisely the right financing

We offer you tailored financing proposals for your machinery or plants. Our financial advice goes hand in hand with our expertise relating to technical questions. Your personal contact person will take care of the whole process.

The benefit for you: The ability to invest without delay in new technologies and remain financially flexible.



Your success in best hands all over the world

The HOMAG Group is present with **1200 service employees** around the world and also relies on more than 60 skilled partners in over 50 countries. We offer a seamless technical support network in order to guarantee the maximum availability of your machines and plants.

1200
Service employees
around the world

85.2 %
less on-site-services through
successful remote diagnosis

650
processed spare parts
orders / day

>150 000
machines, all electronically
documented in 28 different
languages – in **eParts**



Remote Service

- Hotline support via remote diagnosis regarding control, mechanics and process technology. Thus the on-site service can be reduced by 85.2 %!
- Mobile applications such as **ServiceBoard** reduce the costs through fast help in case of troubles by mobile live video diagnosis, online service message and the online spare parts shop **eParts**



Spare Part Service

- Identify, request and order spare parts around the clock via www.eParts.de
- Local availability of parts offered by our sales and service companies as well as sales and service partners all over the world
- Reduction of downtimes through defined spare parts and wear parts kits



Modernization

- Keep your machinery up-to-date and increase your productivity as well as your product quality. This is how you can meet tomorrow's requirements today!
- We support you with upgrades, modernization as well as individual consultancy and developments



Trainings

- The trainings perfectly suit to your requirements. Through this your machine operators can operate and maintain the HOMAG Group machines optimally.
- The trainings also include customer-specific training documents with practice-proven exercises



Software

- Telephone support and consultancy through software support
- Digitalization of your spare parts via 3D scanning saves time and money compared to new programming
- Subsequent networking of your machinery with intelligent software solutions ranging from construction to production

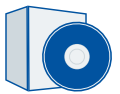

Field Service

- Increased machine availability and product quality by certified service staff
- Regular checks through maintenance / inspection guarantee the highest quality of your products
- We offer you the highest availability of technicians in order to reduce downtimes in case of unpredictable troubles



HOMAG Bohrsysteme GmbH

Benzstrasse 10-16
33442 Herzebrock-Clarholz
Germany
Tel. +49 5245 445-0
Fax +49 5245 445-44139
info-herzebrock@homag.de
www.homag.com



BLUECOMPETENCE

Alliance Member

Partner of the Engineering Industry
Sustainability Initiative



**Choose the Original
Choose Success!**

For the Success of
Original Technology. A
campaign of the VDMA