



Robots

Innovative Material Handling

In many applications, robots simplify the production flow in industrial production. Schelling's new Robotic stacking makes this technology available for Schelling cut-to-size systems. A special gripper – developed by Schelling – allows the stacking of a wide variety of sheet materials and part sizes.

Together with Schelling's existing sorting and stacking components and the in house software developed for Robotic stacking, Schelling offers a complete and all around solution for stacking parts after the cut-to-size process.

Patented gripper arm system for a wide variety of sheet materials

- Optimal handling of even thin sheets
- Precise stacking thanks to innovative stop and alignment systems on the gripper
- Multi-line and multi-row stacking thanks to special holding equipment on the gripper

Optimal interplay of cutting solution and robot stacking

- Everything from a single source: Schelling provides all components and software solutions
- Proven sorting and handling systems from Schelling complete the robot
- Cut plan optimization and stacking program are optimized perfectly to one another

Manually-supported robot stacking

Stack layers are arranged manually after the saw. With the recently developed stacking program, the operator at the stacking terminal (screen) receives precise information with graphic support as to how the next stack layer should be grouped. The operator creates the stack layer and acknowledges the process. From there the stack layer is transferred automatically to the robot's acceptance position where it is re-aligned before stacking.

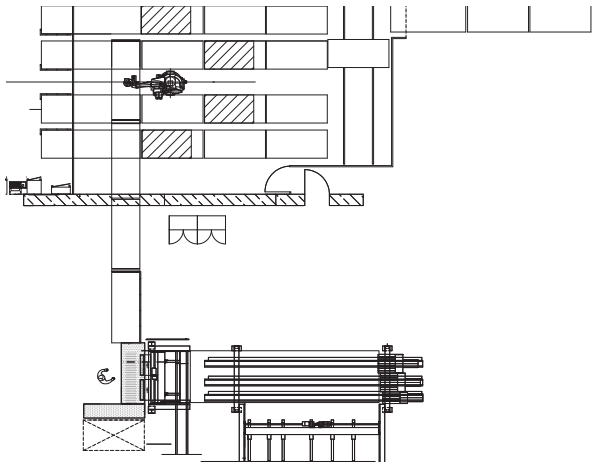

Fully-automatic robot stacking

Various implementations are available for fully-automatic robot stacking solutions. Depending on the output required and the stacking specifications, simple designs with direct acceptance of the parts from a roller track or complex solutions with integrated sorting, turning, manipulation and collection systems can be offered. In addition, it is possible to combine robot stacking with traditional fork or gripper stacking systems.

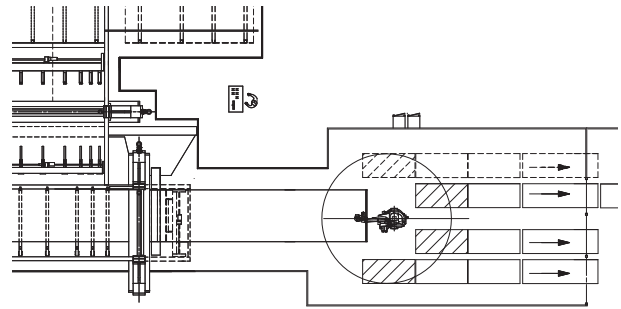

Maximum part format

3,100 x 1,300 mm for sheet thicknesses ≥ 8 mm
 2,100 x 1,300 mm for sheet thicknesses < 6 mm

Minimum part format

300 x 200 mm package heights up to 210 mm

