

PMT



THE MACHINING CENTRE
FOR TIMBER CONSTRUCTION:
**FREEDOM OF
SHAPE AND SIZE.**

PRODUCTIVITY



Extremely wide work areas, extendable up to 8 meters in width and 80 meters in length. Machining possibility on single work area and on double work area with pendulum cycle.

STRENGTH



The advanced structure design guarantees the reduction of vibrations generated by heavy duty stock removal, achieving an excellent combination of execution speed and processing quality.

CONFIGURABILITY

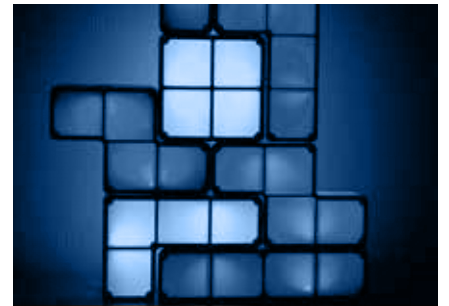

PMT machining centre is characterized by **total modularity**, therefore it is configurable according to the customer's production needs.

OVERVIEW OF TECHNICAL FEATURES

TECHNOLOGICAL ADVANTAGES

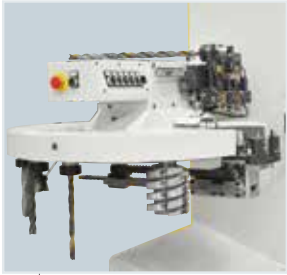

Circular tool store for 16 tools.
Possibility to add one dedicated position for drill bits of maximum length 750 mm.

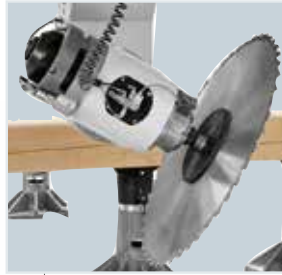

Main 5-axis machining head unit with dedicated extraction system for a complete dust disposal.

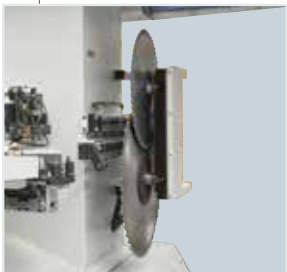

Position for 2 blades respectively of diameter 880 mm and 600 mm, always ready-to-use.

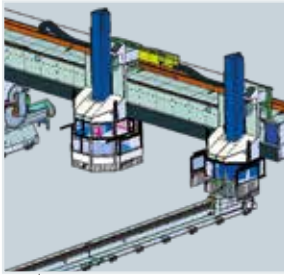

Possibility to equip the machining centre with a **second machining head unit with sawblade**, for a significant performance increase.



Possibility to mount a **supplementary tool store** with collets with pneumatic release, specific for heavy tools.



Suction cups of diameter 250 mm useful for locking the beams during processing.

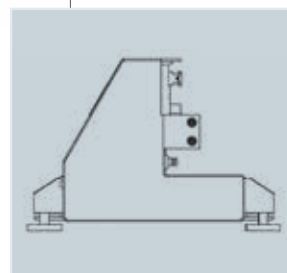

Sturdy structure and tracks base frames firmly on the workshop floor. No need of masonry construction.

APPLICATIONS

pmt is a cnc machining centre with 5 interpolating axes and gantry structure. The SCM solution to process large curved beams with maximum versatility.



LINEAR AXES

X-axis speed	m/min	80
Y-axis speed	m/min	80
Z-axis speed	m/min	30

ELECTROSPINDLE "KX5"

Power at 4300 rpm (S1) max.	kW	32
Rotation max.	rpm	17000
Torque (S1) max.	Nm	68

SAW BLADE MACHINING HEAD UNIT "GL" (OPTION)

Power at 965 rpm (S1) max.	kW	18
Rotation max.	rpm	1445
Torque (S1) max.	Nm	190
Saw blade diameter max.	mm	1120

TOOL STORES

Main circular tool store	n° positions	16
Supplementary circular tool store	n° positions	6
Saw blades store	n° positions	2
Long drill bits store	n° positions	2

COMPOSITION "KX5"

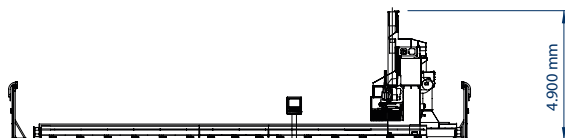

COMPOSITION "KX5" + GL

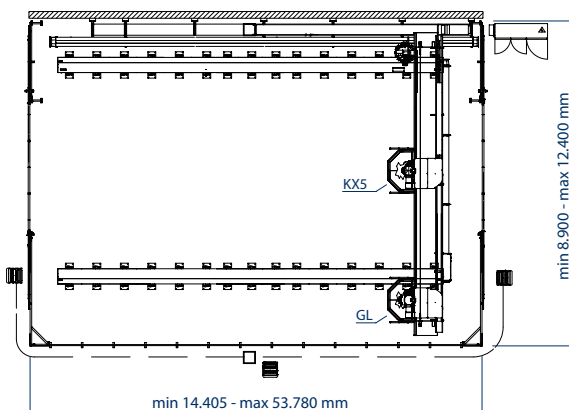
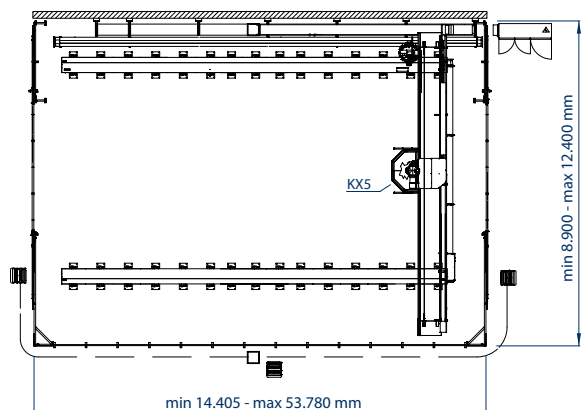
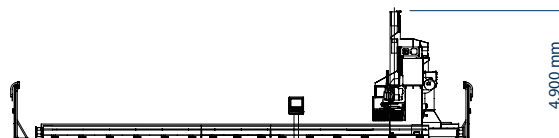

**COMPANY WITH
QUALITY SYSTEM
CERTIFIED BY DNV GL
= ISO 9001 =**

The technical data can vary according to the requested machine composition. In this catalogue, machines are shown with options. The company reserves the right to modify technical specifications without prior notice; the modifications do not influence the safety prescribed by CE Norms.

Maximum recorded noise levels based on functioning parameters established by ISO 3746/95, EN848-3E, UNI EN ISO 11202/97. Acoustic pressure while working 82,5 dB(A) (measured according to EN 848-1, K variance = 4dB). Acoustic power while working 96,3 dB(A) (measured according to EN 848-1, K variance = 4 dB). Despite the existence of a correlation between "conventional" noise emission values mentioned above and average personal exposure of the operators during the 8 hours, these also depend on the specific functioning conditions, length of exposure, acoustics characteristics of the working environment and by the presence of additional sources of noise, that is the number of machines and adjacent processes.



SCM GROUP SPA

via Casale 450 - 47826 Villa Verucchio, Rimini - Italy
tel. +39 0541 674111 - fax +39 0541 674274
scm@scmgroup.com
www.scmwood.com



00L0528785D