

STEFANI

Italiano - English - Español

Squadrabordatrici elettroniche
NC squaring-edgebanders
Escuadradoras-chapeadoras
electrónicas

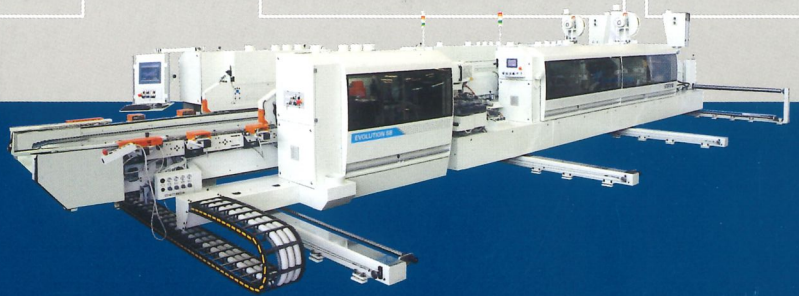

Evolution

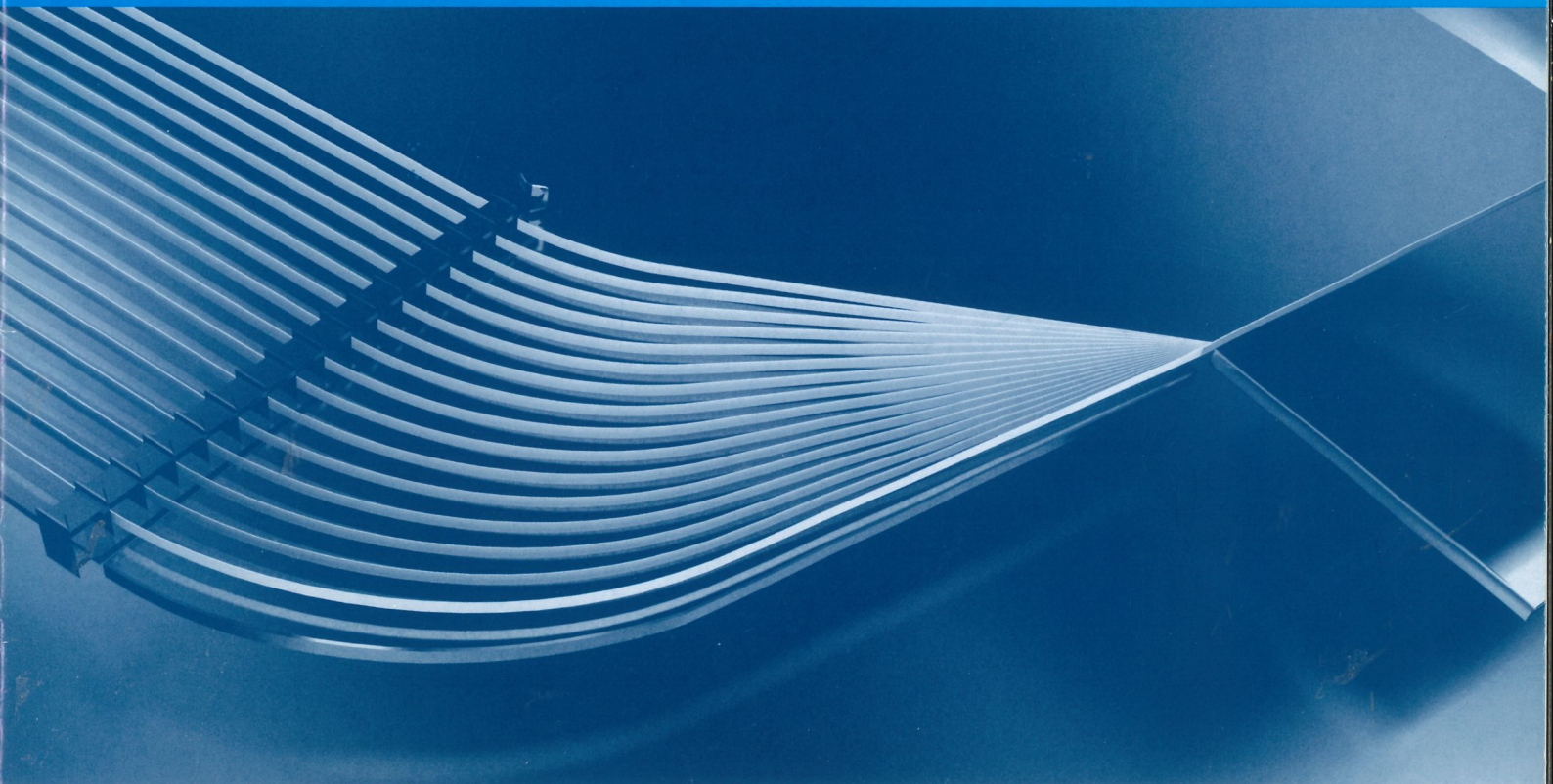

STEFANI

Evolution SSB

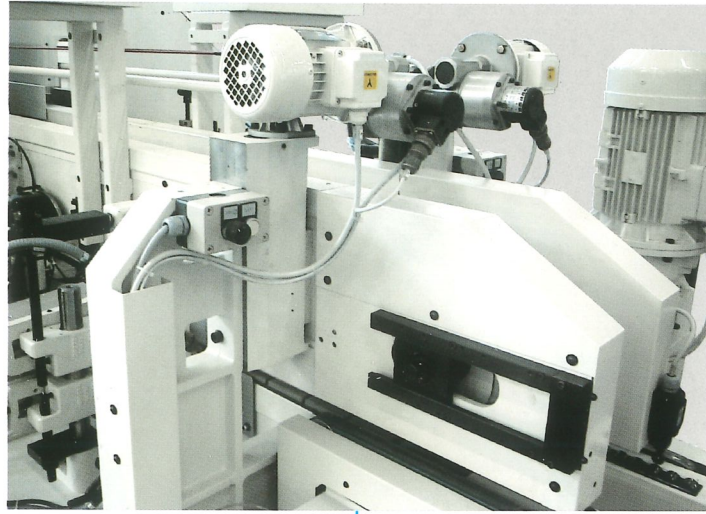

Il **pressore superiore** è costituito da un longherone in acciaio ampiamente dimensionato ed è dotato di sollevamento ad asse controllato.

The **top pressure beam** consists of a full-size steel beam equipped with NC managed positioning.

El **prensor superior** está formado por un larguero de acero de gran tamaño y cuenta con un sistema de levantamiento con eje controlado.

Squadrabordatrice elettronica
NC squaring-edgebander
Escuadradora-chapeadora electrónica

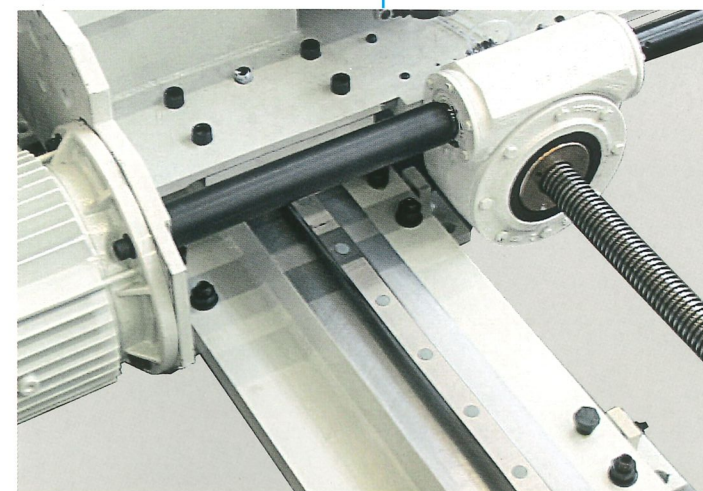
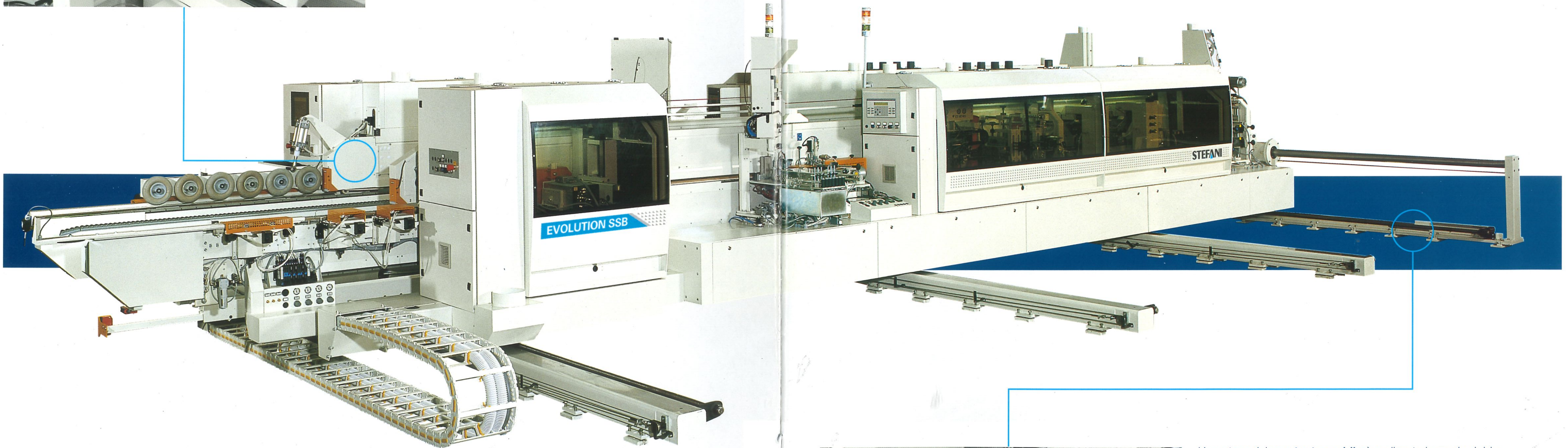

L'apertura del **montante mobile** è realizzata in modo rigido con una trasmissione che agisce su una vite senza fine ad alta precisione. Ciò permette di mantenere un perfetto parallelismo costante nel tempo.

The **movable beam** opening is rigid with a transmission that acts on a high precision worm screw, thus permitting a long term perfect constant parallelism.

La abertura del **montante móvil** se lleva a cabo en modo rígido con una transmisión que actúa sobre un tornillo sin fin de alta precisión. Eso permite mantener un paralelismo perfecto y constante en el tiempo.

Evolution SB

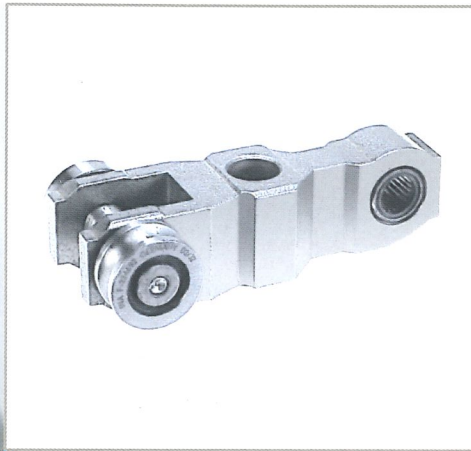
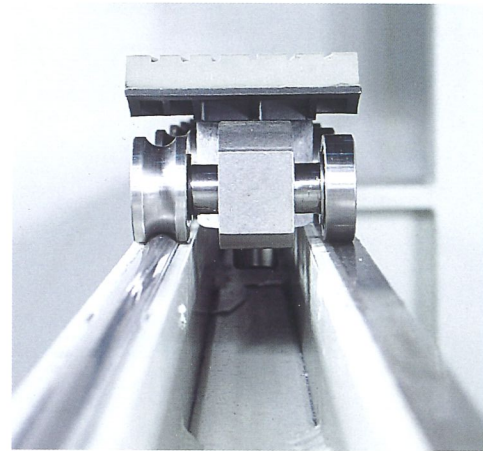

Il **cingolo** scorre su guida tonda e piana mediante cuscinetti lubrificati che consentono di ridurre al minimo l'attrito e di ottenere un'elevata precisione e rettilinearità di avanzamento.

The **track** runs on round and flat guides by means of lubricated bearings which reduce friction to a minimum and permit high feed precision.

La **cadena** se desliza sobre una guía redonda y plana mediante cojinetes lubricados que permiten reducir al mínimo la fricción y obtener una elevada precisión y avance rectilíneo.

Squadrabordatrice elettronica
NC squaring-edgebänder
Escuadradora-chapeadora electrónica

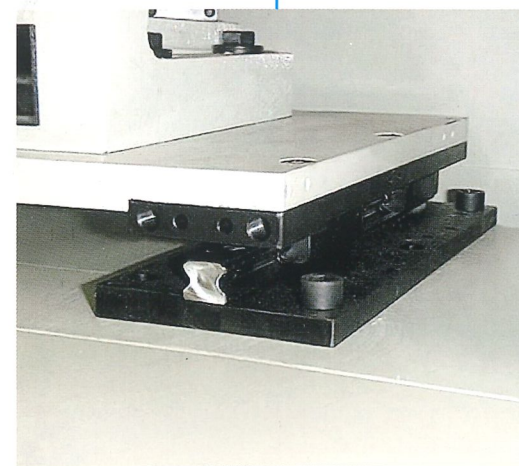

I gruppi di lavoro sono posti su **sopratavole** con la possibilità di spostamenti su guide lineari a ricircolo di sfere.

Sub-bases on every working unit with possibility of movements on caged ball linear guides.

Los grupos de trabajo están instalados en **sobremesas** con la posibilidad de desplazamiento sobre guías lineares con recirculo de bolas.

Evolution Flex



La squadraboardatrice **Evolution Flex** è in grado di fornire prestazioni diversificate in tempi rapidi, per permettere la lavorazione in serie di piccoli lotti, con un'efficienza adeguata a garantire al cliente al cliente tempi brevi di consegna.

The squaring-edgebander **Evolution Flex** can provide different kinds of performance in a short time: this is to allow the serial processing of small batches with a short delivery time.

La escuadra chapeadora **Evolution Flex** está en condición de garantizar prestaciones distintas en tiempos rapidos, para permitir el trabajo en serie de pequeños lotes, con una eficiencia adecuada a garantizar al cliente tiempos breves de entrega.

Squadraboardatrice flessibile
Flexible squaring-edgebander
Escuadra chapeadora flexible

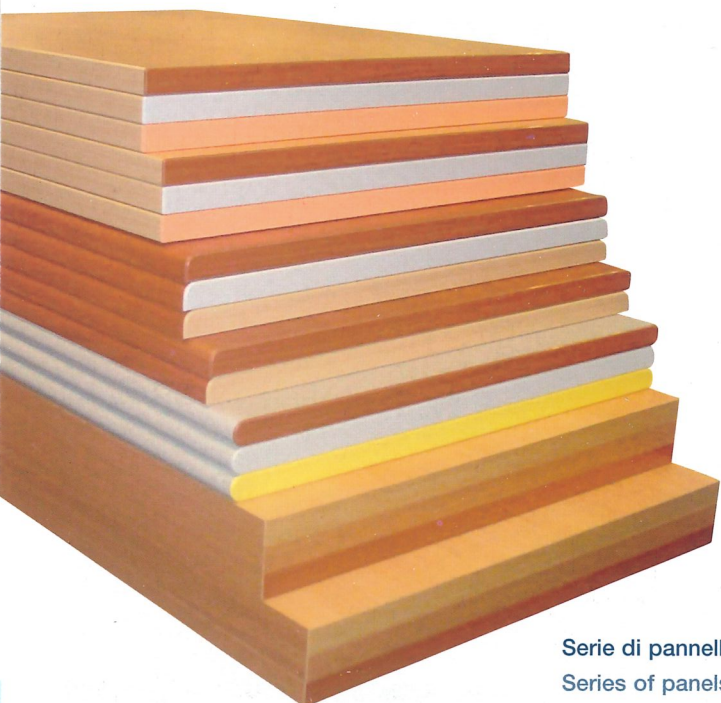
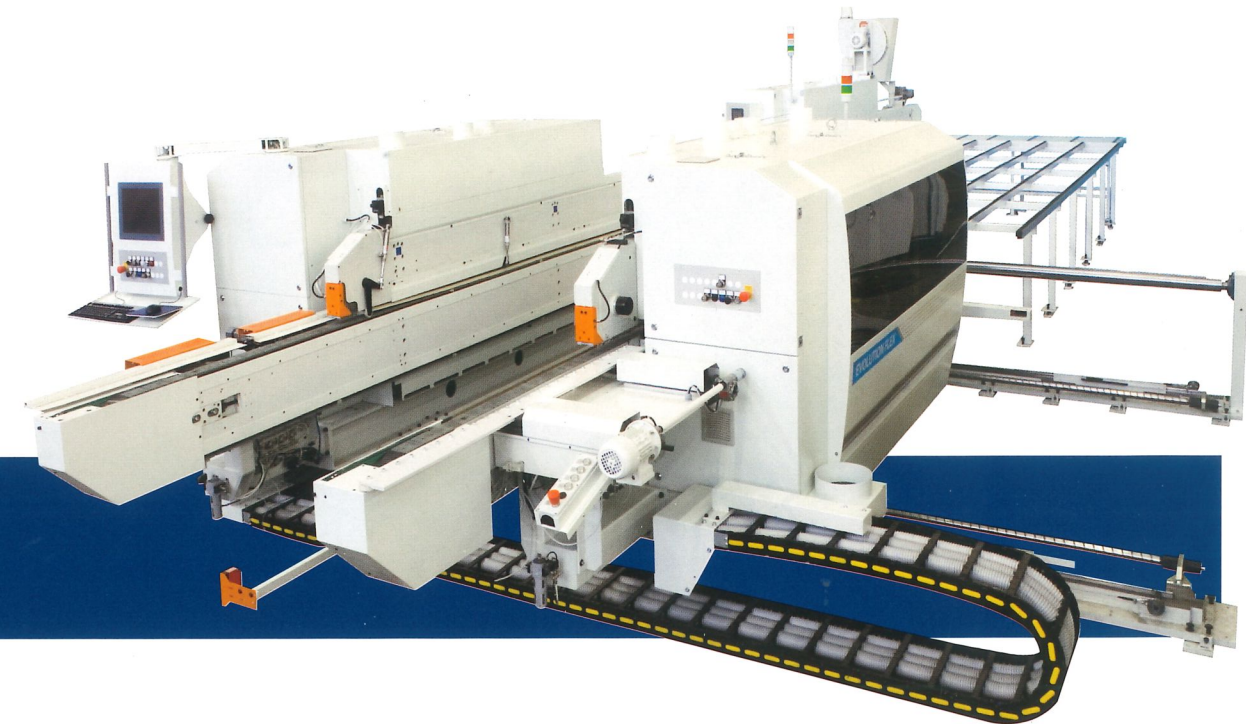
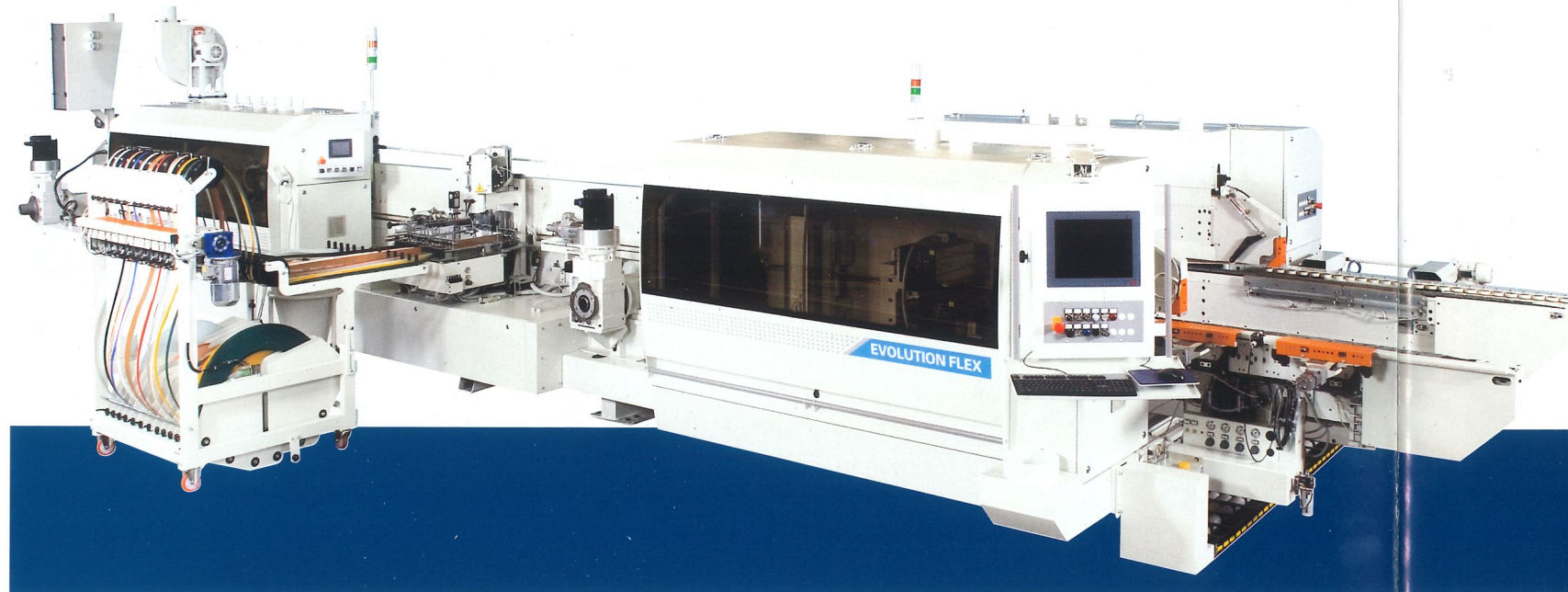

Serie di pannelli lavorati in sequenza
Series of panels worked in sequence
Serie de paneles trabajados en secuencia

- | | |
|---|---|
| Sistema di carico
Loading system
Sistema de carga | 1 |
| Squadraboardatrice elettronica flessibile
Flexible squaring-edgebander
Escuadra chapeadora flexible | 2 |
| Sistema trasporto pannello
Panel conveyor system
Sistema transporte paneles | 3 |
| Introduttore pannelli
Panels infeed system
Sistema de introducción paneles | 4 |
| Bordatrice monolaterale
Single-sided edgebander
Chapeadora monolateral | 5 |
| Sistema di scarico
Unloading system
Sistema de descarga | 6 |

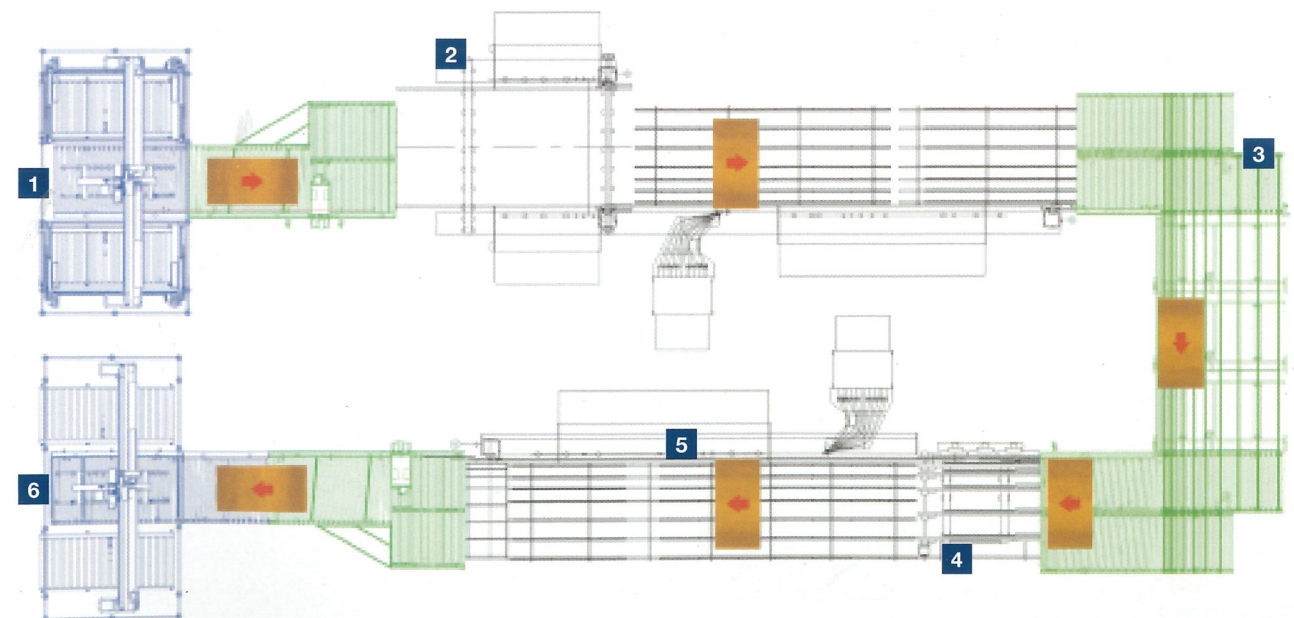

Esempio di linea flessibile Example of flexible line Ejemplo de línea de trabajo flexible

Evolution 60

Evolution 60: larghezza minima del pannello 60 mm.

Evolution 60 è una macchina dedicata alla produzione di pezzi stretti: è la risposta ai clienti che richiedono alte prestazioni unite a dimensioni particolari dei pannelli.

Evolution 60: minimum panel width 60 mm.

Evolution 60 is a machine designed to produce narrow workpieces. It is designed to meet the demands of customers requiring high performance and special panel sizes.

Evolution 60: ancho mínimo del tablero 60 mm.

Evolution 60 es una máquina dedicada a la producción de piezas estrechas: es la respuesta a la demanda de aquellos clientes que requieren altas prestaciones y dimensiones especiales de los tableros.



Linea Evolution 60
Evolution 60 line
Línea de trabajo
Evolution 60

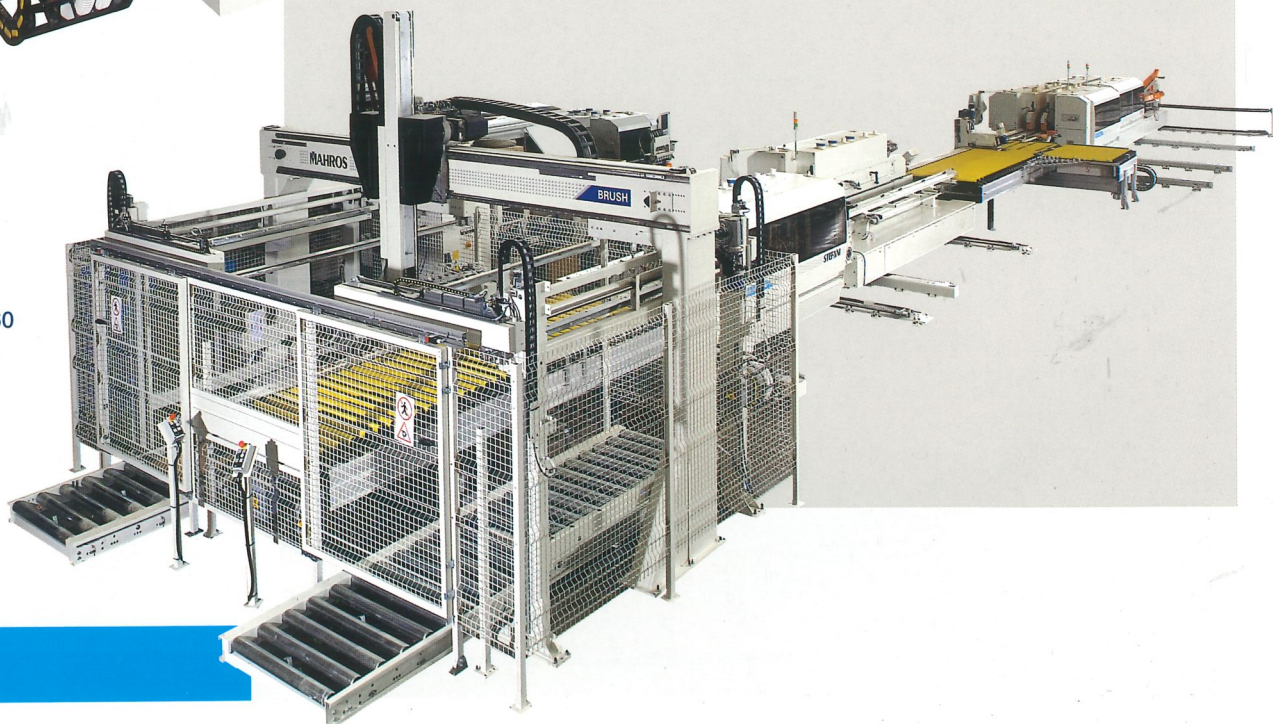

Evolution

per porte
for doors
para puertas

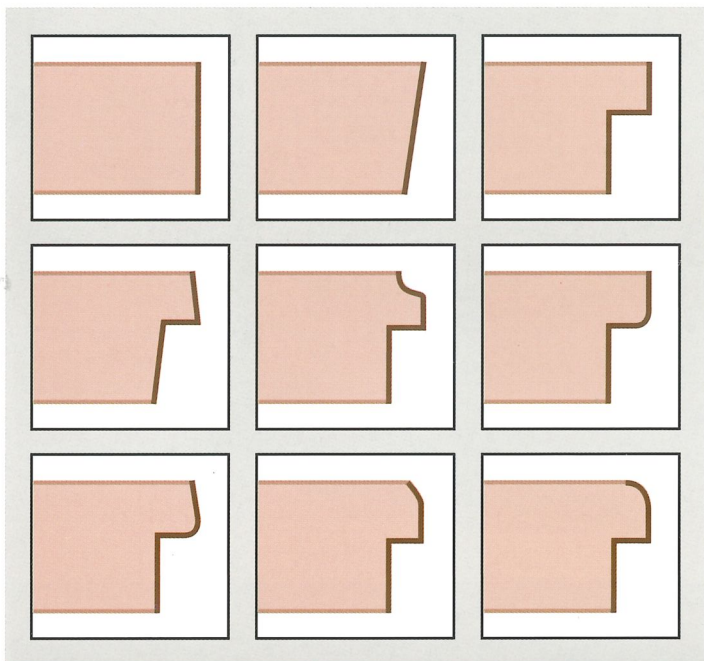

Profili di porte
Door profiles
Perfiles de portas

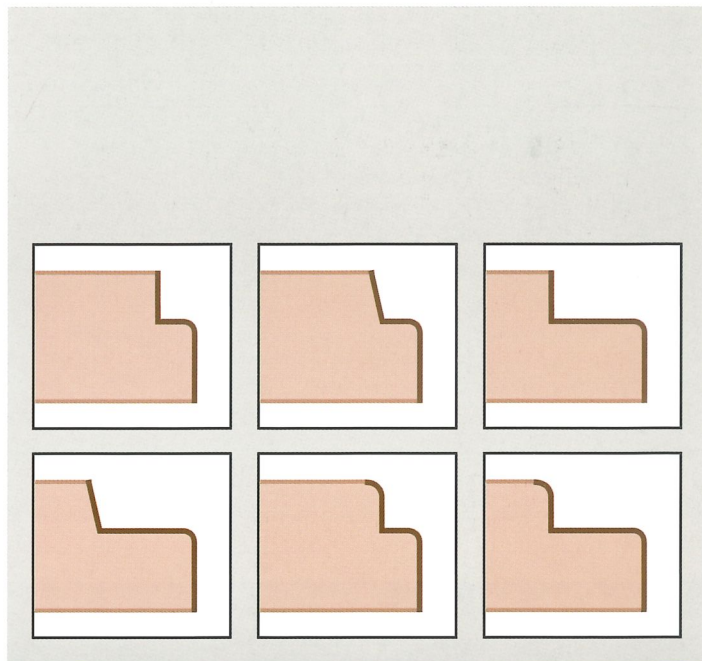

Profili di stipiti
Door frame profiles
Perfiles de jambas

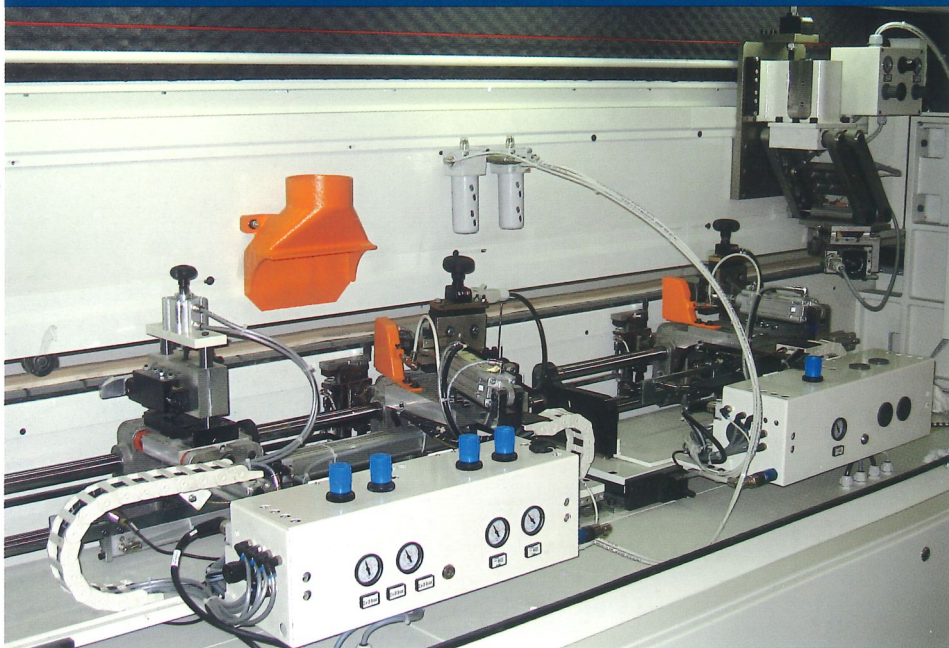

Gruppi di finitura degli angoli delle porte
Door corner finishing units
Grupos retoque de los ángulos de las portas



Gruppo levigatore a disco
Disk sanding unit
Grupo alisador de disco

PC Office

PC Office

PC Office

Le squadratrici Evolution sono dotate di **PC Office** che opera in ambiente Windows XP e consente di gestire la macchina in modo semplice, rapido e senza errori.

Evolution squaring-edgebanders are equipped with **PC Office** working in Windows XP, which allows easy, quick and precise machine management.

Las escuadradoras-chapeadoras Evolution están provistas de **PC Office** que trabaja en ambiente Windows XP y permite dirigir la máquina de manera simple, rápida y sin errores.

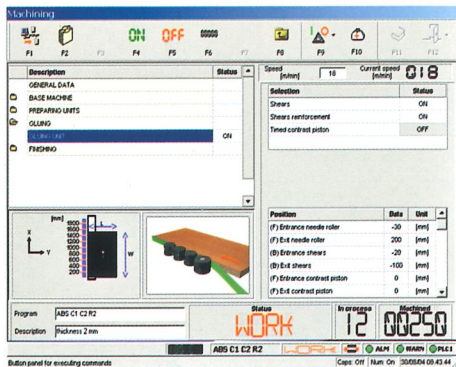

Numero illimitato di programmi di lavoro memorizzabili.
Selezione del primo o secondo passaggio senza cambio programma.

Unlimited number of processing programmes. Selection of the first or second pass without changing the program.

Número ilimitado de programas de trabajo memorizables. Selección de la primera y segunda pasada sin cambio de programa.

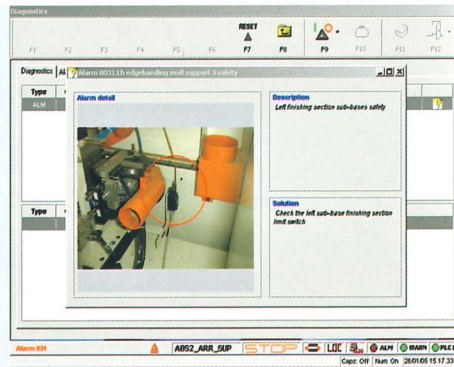

Gestione della diagnostica

Nel caso di stato macchina in allarme, il PC segnala i dettagli dell'allarme e visualizza la zona della macchina nella quale l'allarme si è verificato, guidando, così, il cliente alla risoluzione del guasto.

Trouble shooting

In case of machine in warning, the PC visualizes the alarm, identifies the reasons of alarm and finds out where the alarm is on the machine. Therefore the PC leads the customer to the solution of the warning.

Gestión de los diagnósticos de errores

Si la máquina se para por una alarma, el PC señala los detalles de las alarmas y visualiza la zona de la máquina en la que hay la alarma, conduciendo, así, al cliente hasta la resolución de la falla.

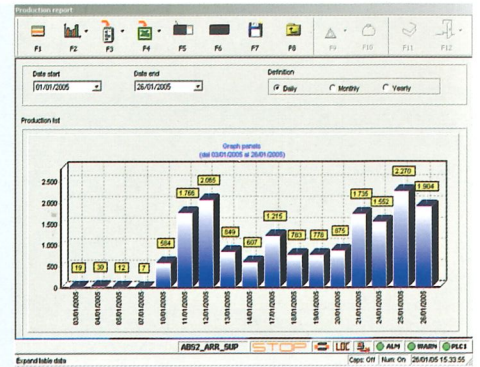

Report di produzione

Programmi di lavorazione, pannelli lavorati, bordo utilizzato, con definizione giornaliera, mensile e annuale. I report di produzione permettono di tenere sotto controllo l'andamento della produzione, in modo statistico con grafici o con semplici fogli Excel.

Production reports

Processing data, worked panels, used edge, daily, monthly and yearly. Reports allow production monitoring by statistic graphics and Excel files.

Report de producción

Programas de trabajo, tableros trabajados, canto empleado, con definición cotidiana, mensual y anual. Los reportes de producción permiten controlar el desarrollo de la producción, de manera estadística con gráficos o con hojas de Excel sencillas.

Interfaccia
ufficio-macchina

Office-machine
interface

Interfaz oficina-
màquina

Reparto produzione
Workshop
Sección producció

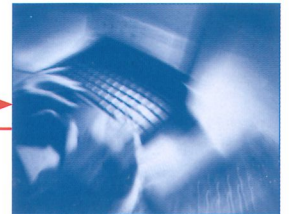

Ufficio
Office
Oficina

Attraverso il PC Office è possibile programmare la macchina direttamente dall'ufficio e ricevere dalla macchina i report di produzione.

Through the PC Office it's possible to program the machine directly from the office and to receive production reports directly from the machine.

Por medio del PC Office es posible programar la máquina directamente desde la oficina y recibir desde la máquina los reportes de producción.

Teleassistenza

Teleservice

Teleasistencia

Azienda cliente
Customer premises
Empresa cliente



Assistenza STEFANI
STEFANI after sales
department
Asistencia STEFANI

Con il servizio di teleassistenza viene assicurato al cliente un immediato intervento da parte dei tecnici STEFANI nelle situazioni di allarmi o errori durante il funzionamento della macchina. Alla richiesta di intervento da parte del cliente, i tecnici STEFANI si collegano via modem al PC della macchina situata nello stabilimento cliente e, in tempo reale, effettuano operazioni sul software per riportare la macchina in condizioni ottimali. Tramite teleassistenza, inoltre, è possibile realizzare modifiche o aggiornamenti dei programmi su richiesta dal cliente.

Through teleservice is assured to the customer an immediate intervention from STEFANI technicians in situation of warnings during the machine process. Further to the request of intervention about the customer, STEFANI technicians will connect by modem to the PC situated on the customer machine and, in real time, they will resolve the software problems and re-set the machine in the best conditions. Besides, through teleservice it's possible to modify or update the programs according to customer requests.

Con el servicio de teleasistencia se asegura al cliente una inmediata intervención por parte de los técnicos STEFANI en las situaciones de alarmas o errores durante el funcionamiento de la máquina. Con el pedido de intervención por el cliente, los técnicos STEFANI se conectan via modem al PC de la máquina situada en la fábrica del cliente y, en tiempo real, efectúan operaciones sobre el software para volver la máquina a las condiciones óptimas. Por medio de teleasistencia, además, es posible realizar modificaciones o reajuste de los programas sobre pedido por el cliente.

Sistema di introduzione del pannello

Panel infeed system

Sistema de introducción del panel

Le squadrabordatrici Evolution sono dotate di un sicuro sistema di introduzione del pannello, condizione fondamentale per ottenere una perfetta squadratura del pezzo.

Evolution squaring-edgebanders have a safe panel infeed system, a fundamental condition to obtain perfect panel squaring.

Las escuadradoras-chapeadoras Evolution están dotada de un sistema seguro de introducción del panel, condición fundamental para obtener un escuadrado perfecto de la pieza.

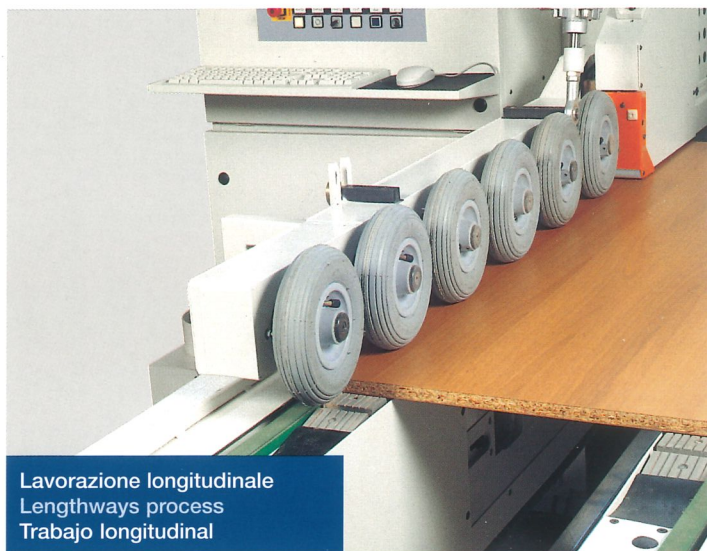

Lavorazione longitudinale
Lengthways process
Trabajo longitudinal

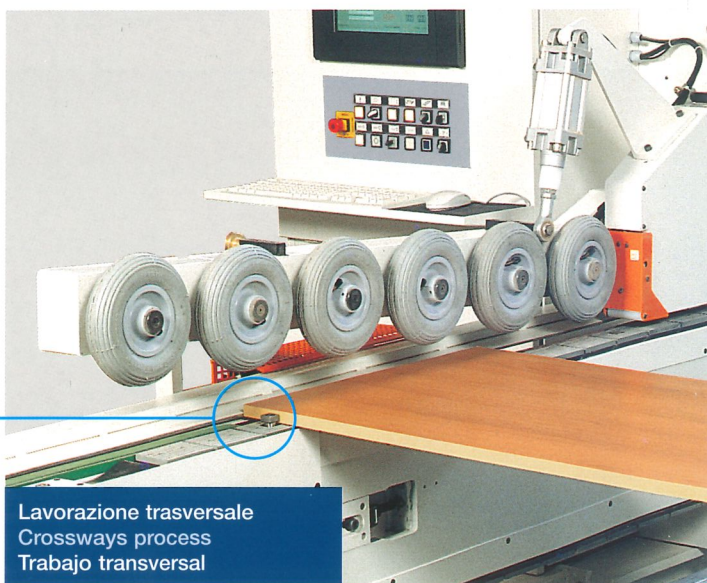

Lavorazione trasversale
Crossways process
Trabajo transversal

Il sistema di attesa dei pioli con settore a feltro sezionato garantisce alta produttività e protegge i pannelli con rivestimento più delicato.

The dogs waiting system with divided felt sector guarantees high productivity and allows to protect the soft surfaces panels.

El sistema de espera de los tetones con sector de fieltro seccionado garantiza elevada productividad y protege los tableros con revestimiento más delicado.

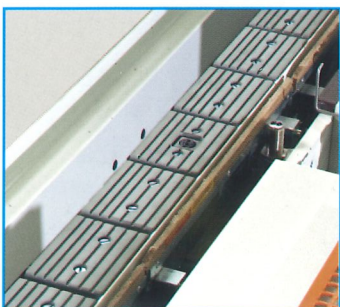

Squadratura
del pannello

Panel squaring

Escuadrado
del panel

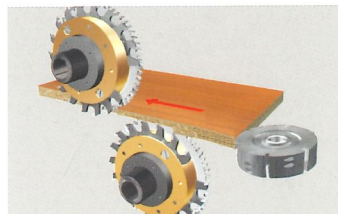
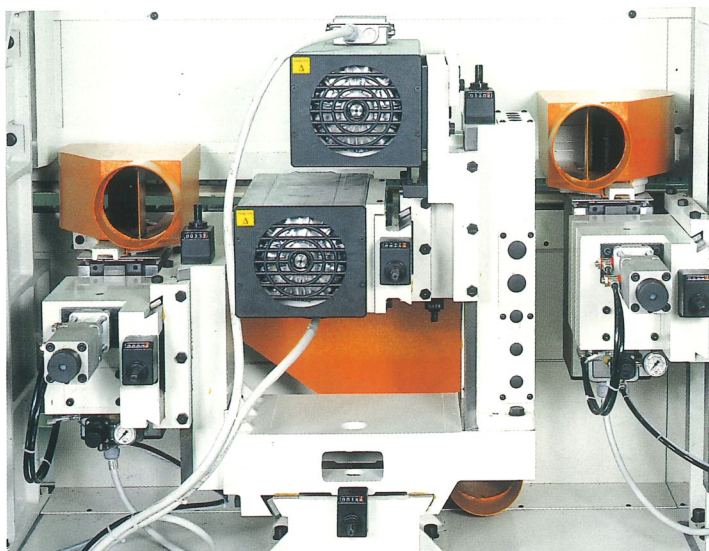

Gruppo antischeggia -
doppio truciolatore

Anti-chipping and
double hogging unit

Grupo antiastilla -
doble triturador

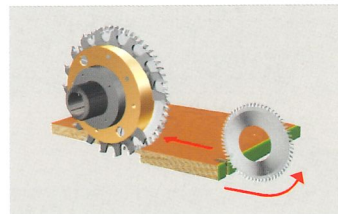
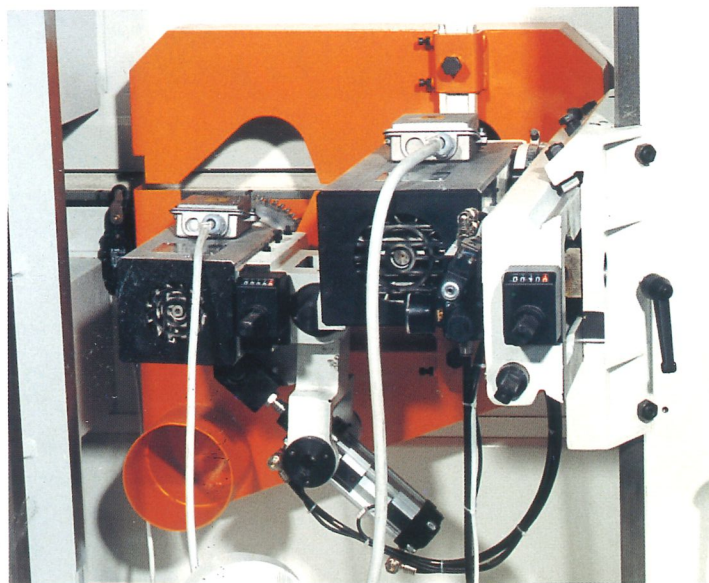
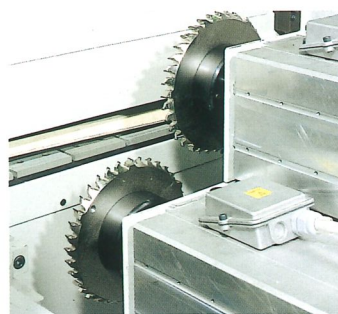

Gruppo incisore - truciolatore

Scoring and hogging unit

Grupo incisor - triturador

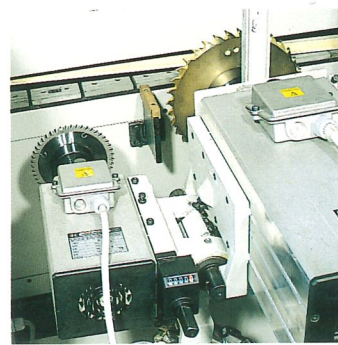

Gruppo rettificatore

Pre-milling unit

Grupo rectificador

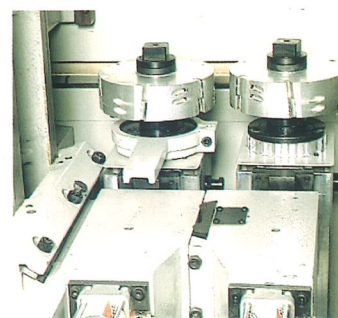

Incollaggio del bordo

Gluing application

Encolaje del canto

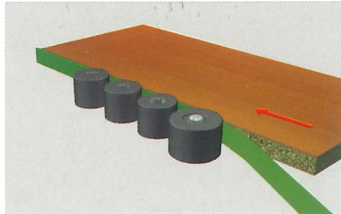

Gruppo incollaggio
Gluing unit
Grupo encolador

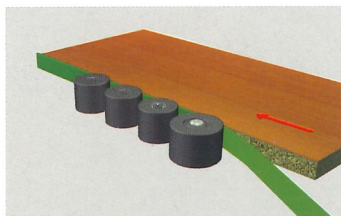
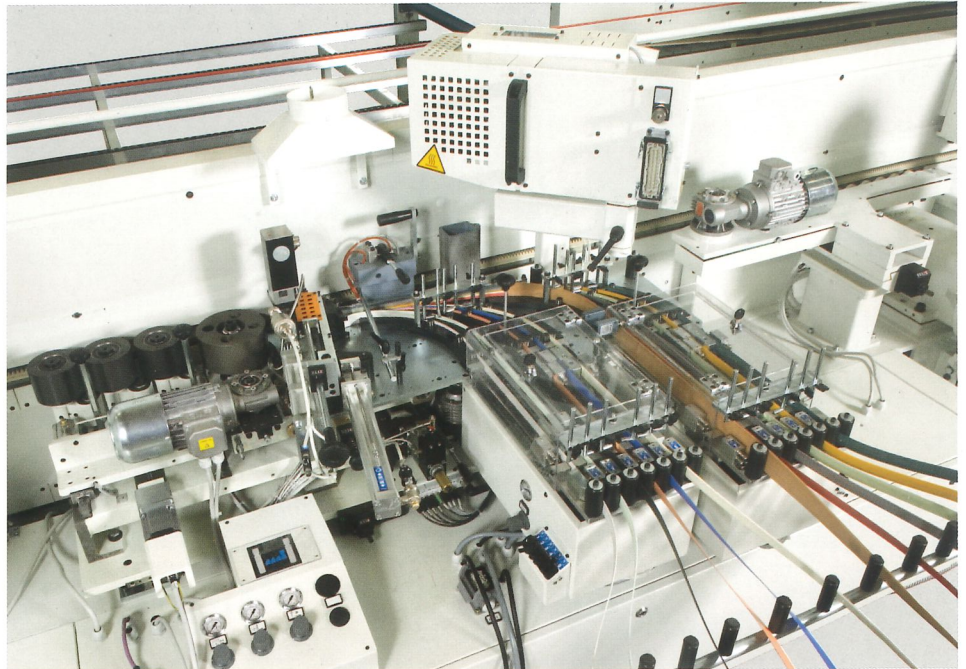

Gruppo incollaggio
Gluing unit
Grupo encolador



Evolution

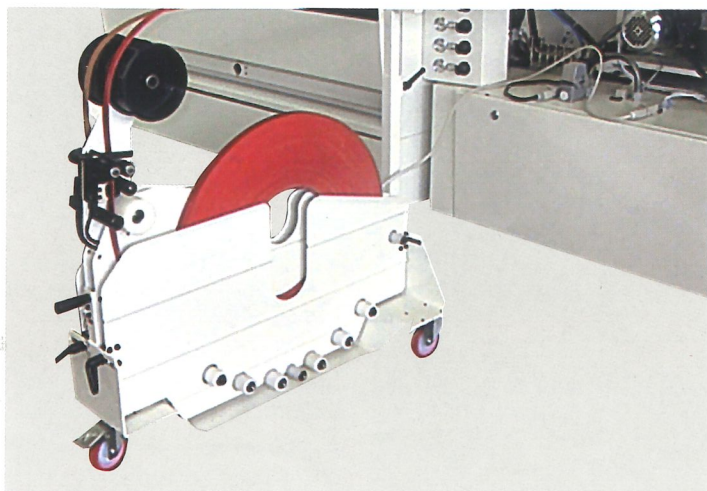

Portarotoli da 2 a 12 rotoli
2 to 12 coils holders
Llevarollos desde 2 hasta 12 rollos



Kit applicazione colla poliuretana (PUR)
PUR glue process device
Kit aplicación cola poliuretánica (PUR)



Gruppi
di finitura

Finishing
units

Grupos
de acabado

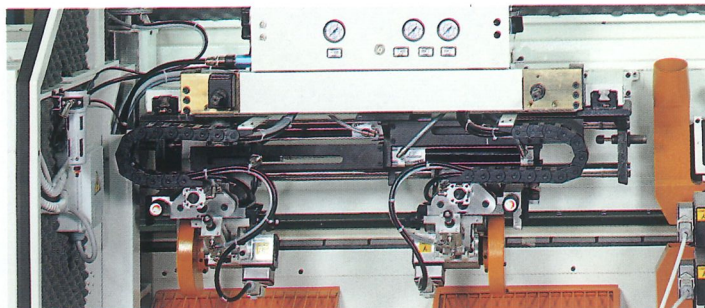
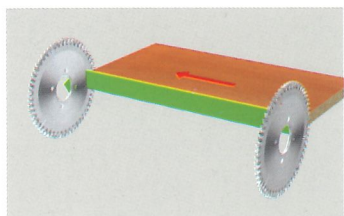

Gruppo intestatore
End-trimming unit
Grupo retesteador

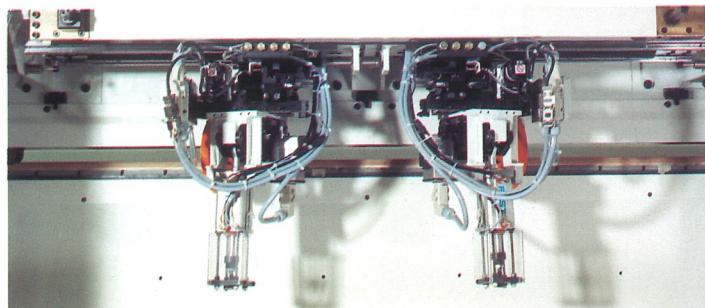
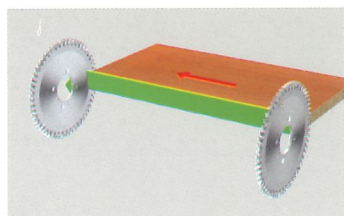

Gruppo intestatore
elettronico
NC controlled
end-trimming unit
Grupo retesteador
electrónico

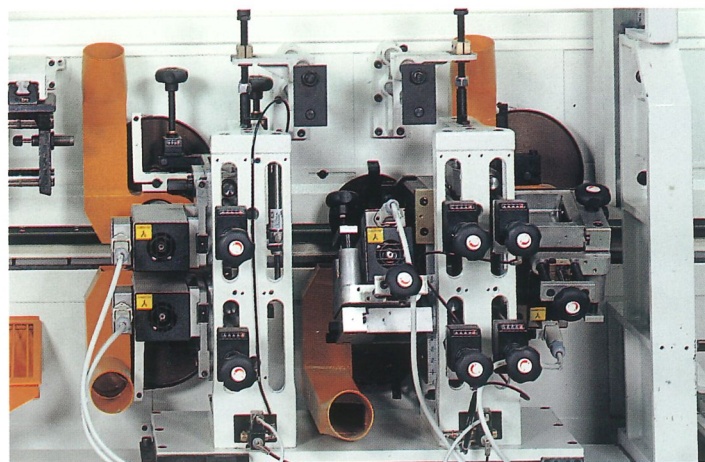
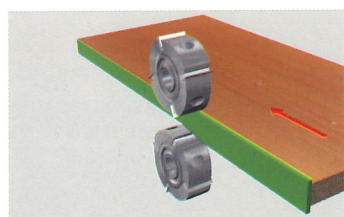

Gruppo rifilatore
Trimming unit
Grupo refilador

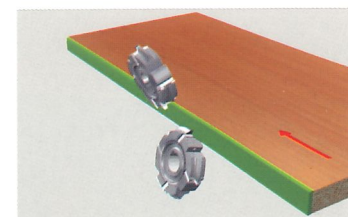

Gruppo spigolatore
Fine trimaming unit
Grupo biselador

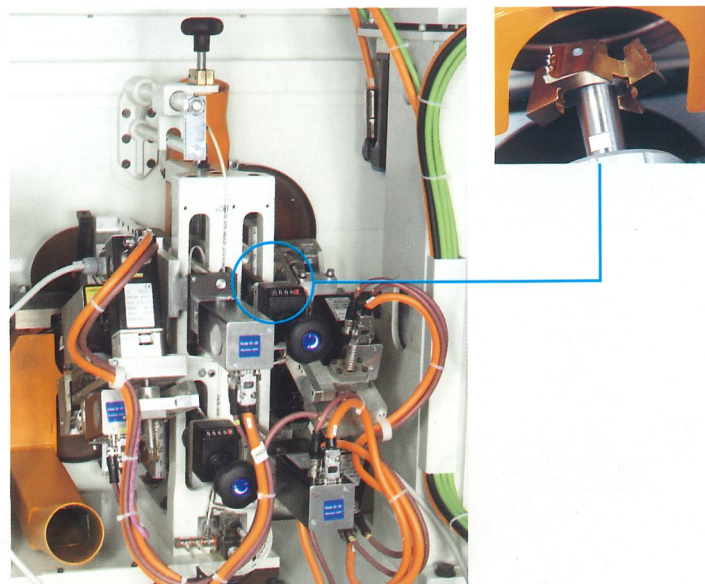

Gruppo spigolatore
multifunzione
Multifunctional
fine trimming unit
Grupo biselador
multifunción

Evolution

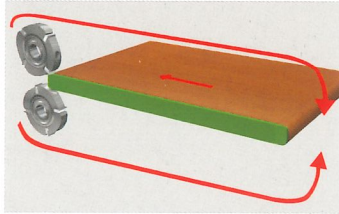

Gruppo arrotondatore-
spigolatore elettronico con
cambio utensili automatico

NC controlled corner rounding
trimming unit with automatic
tool change over

Grupo redondeador-biselador
electrónico con cambio herra-
mientas automático

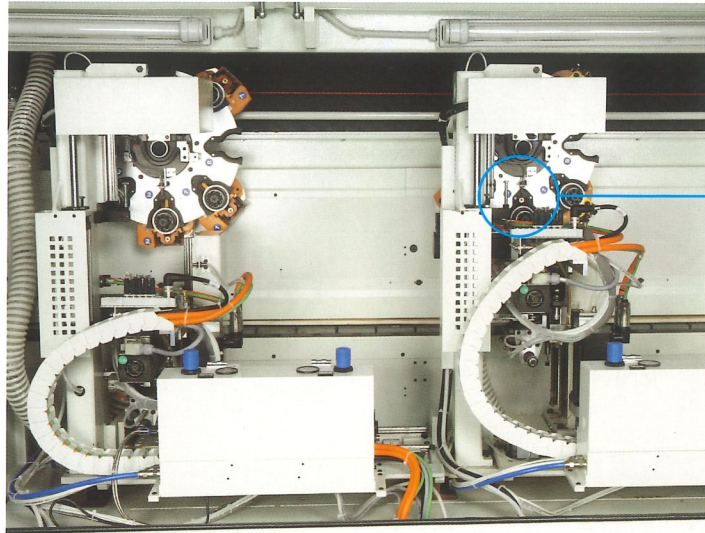

edsystem

Il sistema di aspirazione ottimizzato
ED-SYSTEM migliora la qualità
e il rendimento dell'aspirazione
utilizzando utensili e cappe
di aspirazione specificatamente
studiati per questo scopo.

The optimized ED-SYSTEM
improves the chip suction's quality
and performance by means of
tools and suction hoods precisely
designed for this purpose.

El sistema de aspiración
optimizado ED-SYSTEM mejora
la calidad y el rendimiento de
l'aspiración utilizando herramientas
y campanas de aspiración
Estudiados específicamente para
este objeto.

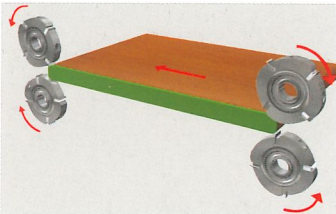

Gruppo arrotondatore
4 motori

4 motors corner
rounding unit

Grupo redondeador
4 motores

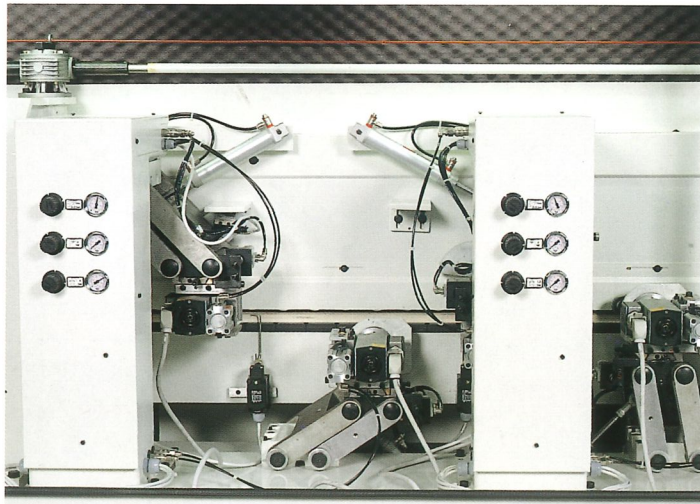

Gruppo arrotondatore
4 motori multifunzione

Multifunctional 4 motors
corner rounding unit

Grupo redondeador
4 motores multifunción

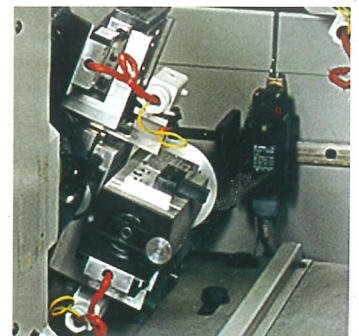
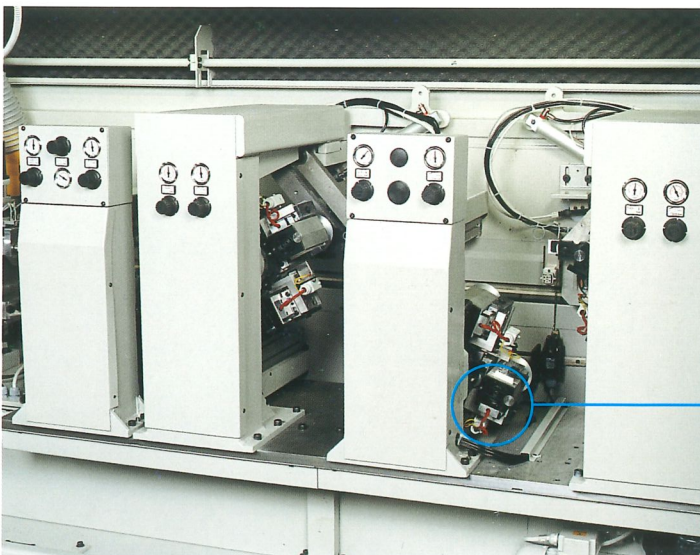

Gruppi di finitura

Finishing units

Grupos de acabado

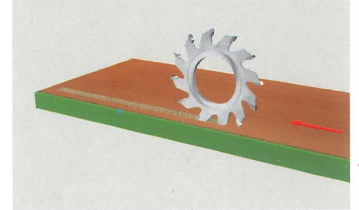
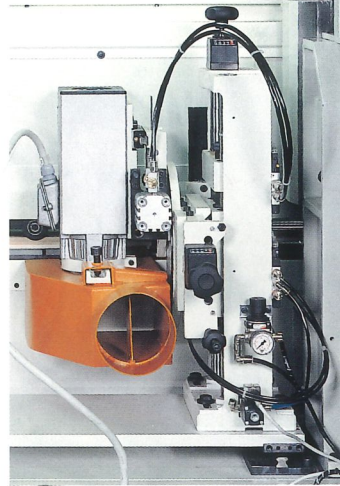
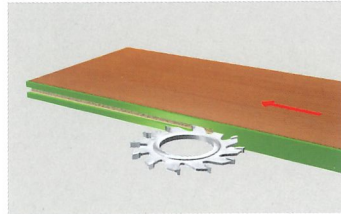

Gruppo toupie
Grooving unit
Grupo tupí para ranuras

Gruppo toupie elettronico con cambio utensili automatico

NC controlled grooving unit with automatic tool change over

Grupo tupí para ranuras electrónico con cambio herramientas automático

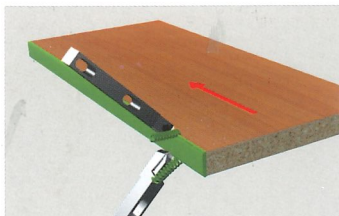
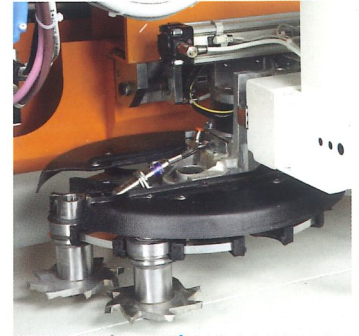
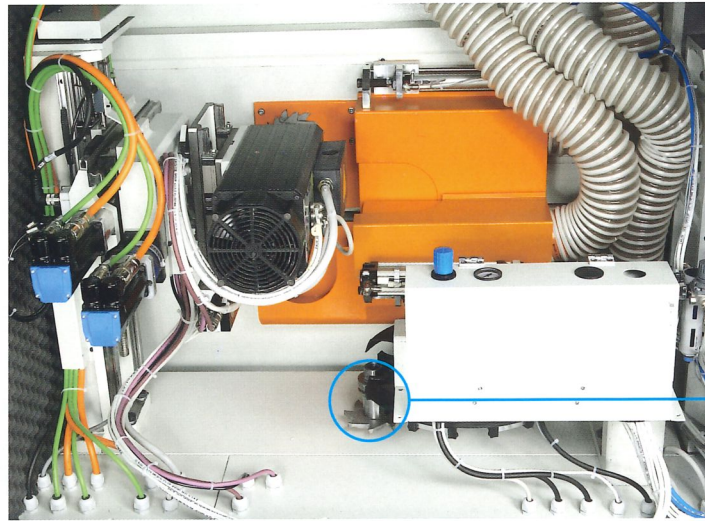

Gruppo raschiabordo
Edgescraping unit
Grupo rascador

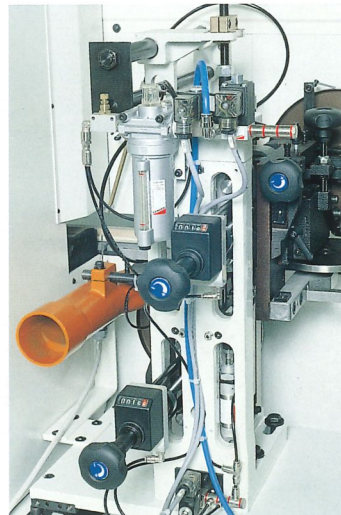

Gruppo raschiabordo multifunzione
Multifunctional edgescraping unit
Grupo rascador multifunción

Evolution

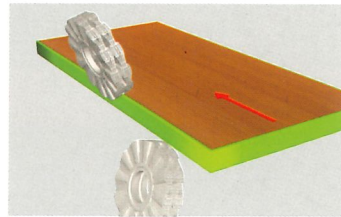
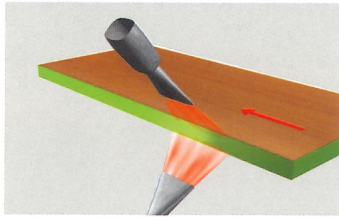
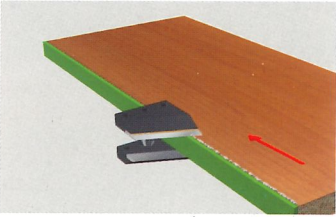
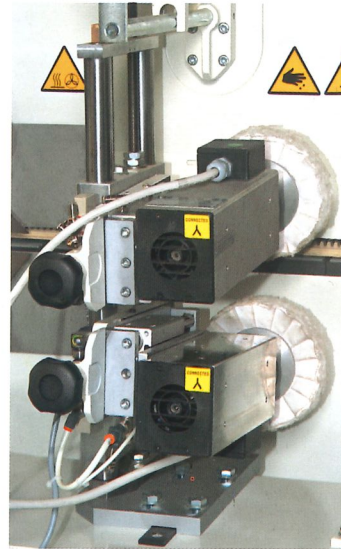
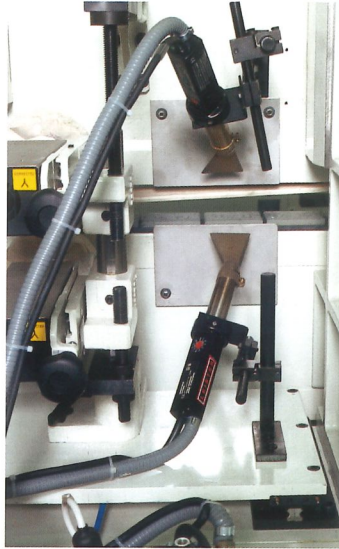

Gruppo raschiacolla
Gluescraping unit
Grupo rascacola

Gruppo ravvivatore bordo
Edge brightening unit
Grupo avivador canto

Gruppo spazzole
Buffing unit
Grupo cepillos

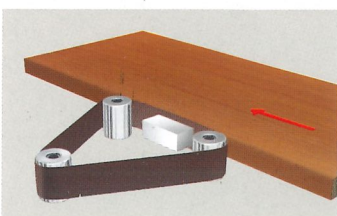
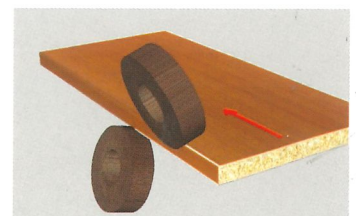
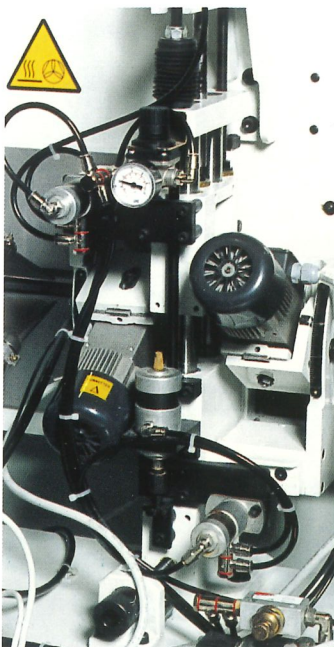
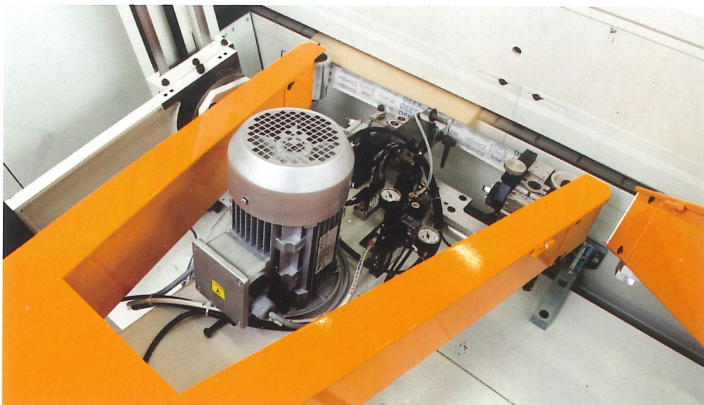

Gruppo levigatore
Sanding unit
Grupo lijador

Gruppo tinteggiatore
Staining unit
Grupo coloreador

Lavorazioni
softforming

Softforming
processing

Trabajo
softforming

Profili softforming
Softforming profiles
Perfiles softforming

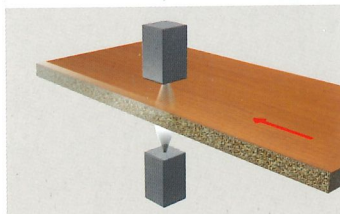
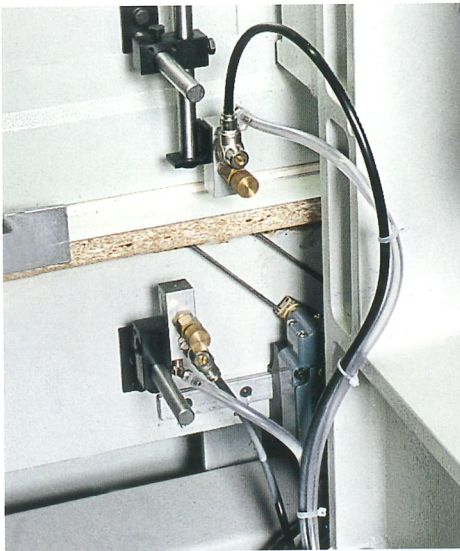
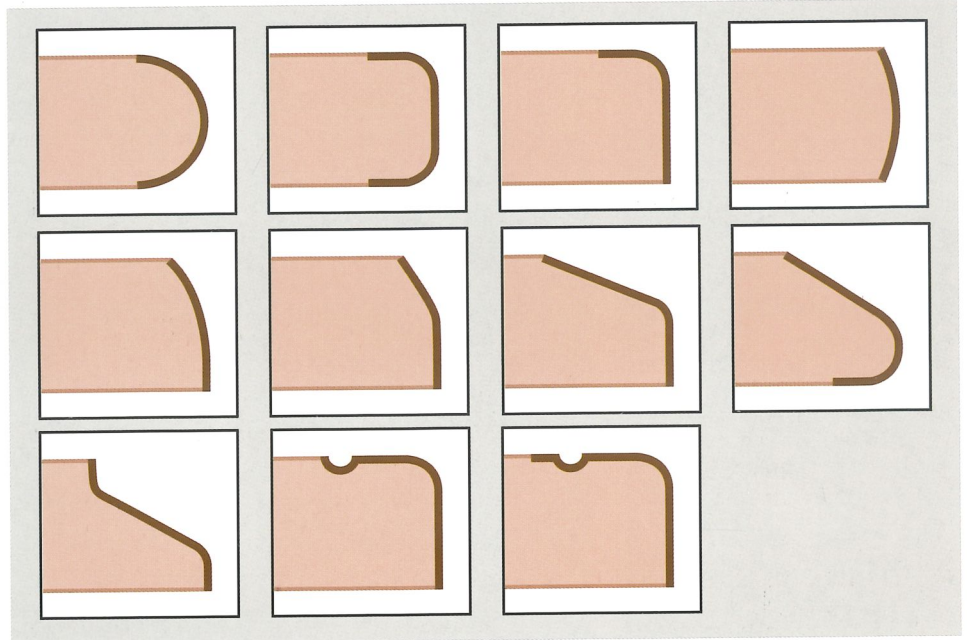

Gruppo antiadesivizzante
Anti-adhesive unit
Grupo antiadhesivo

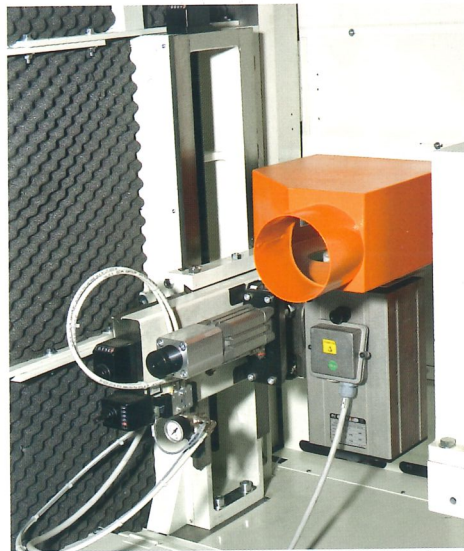

Gruppo fresatore
Milling unit
Grupo fresador

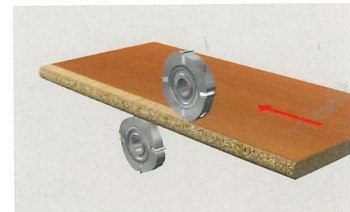

Gruppo profilatore per complanare
Inlay shaping unit
Groupe perfilador para coplanar

Lavorazioni
softforming

Softforming
processing

Trabajo
softforming

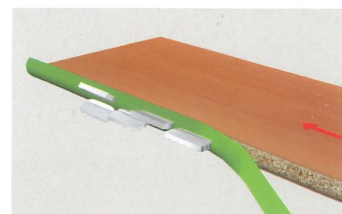
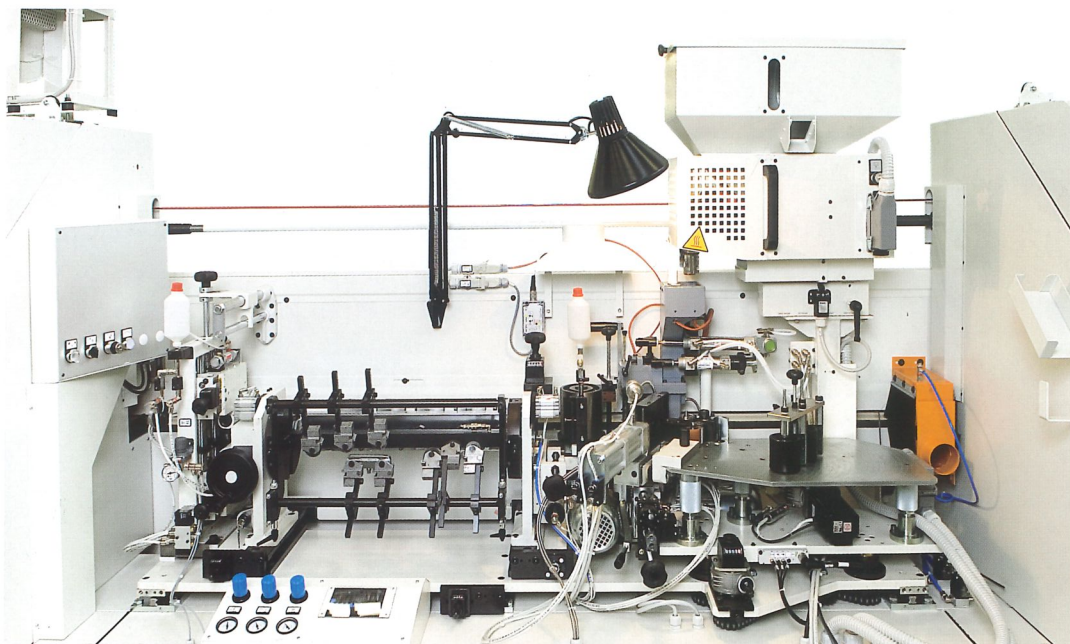

Gruppo incollaggio
softforming

Softforming gluing unit

Grupo encolador
softforming

Cambio settori di pressione
a revolver
Pressure sectors change over
by revolver system
Cambio sectores de presión
a revolver

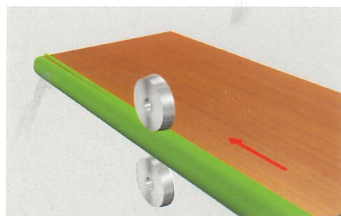
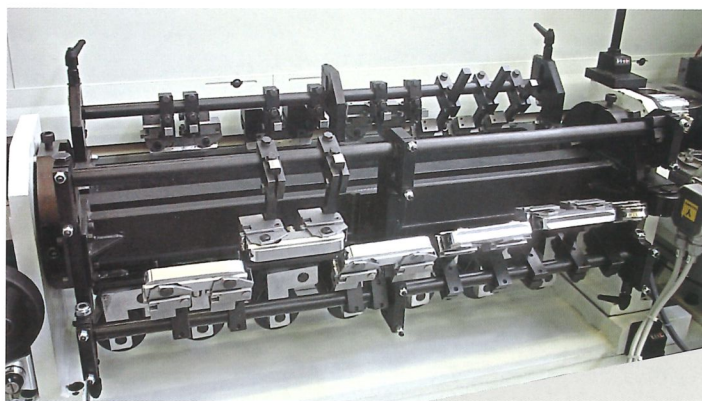

Gruppo cesoia longitudinale
Longitudinal shear unit
Grupo cizalla longitudinal

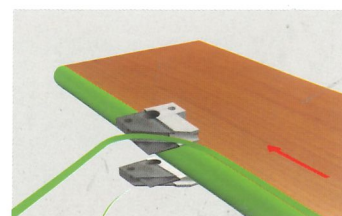
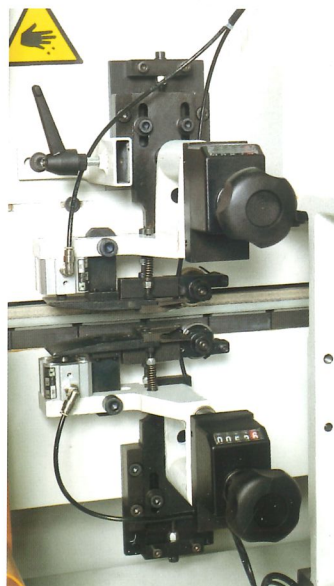
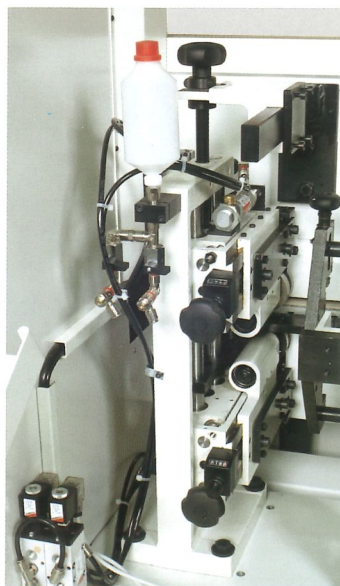

Gruppo raschiafilo
Scraping unit
Grupo rascador de aristas

Applicazione
bordi in alluminio

Aluminium
edge processing

Aplicación
de canto de aluminio

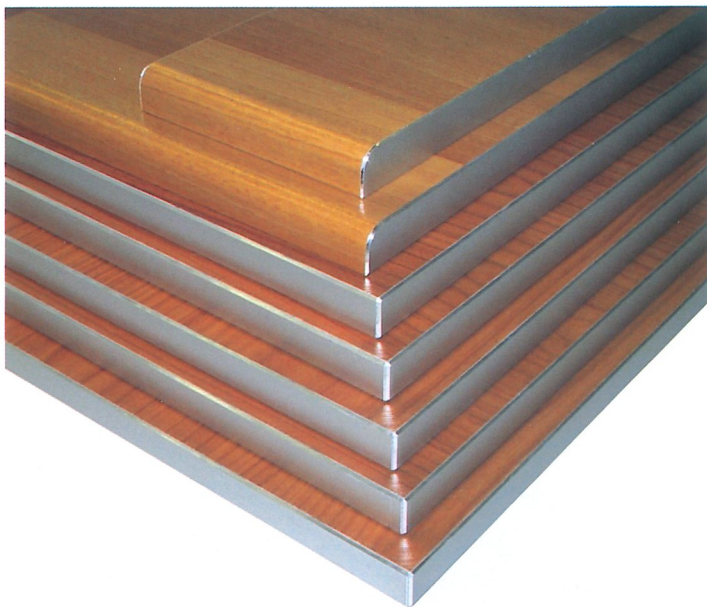

La tecnologia sviluppata da Stefani per l'applicazione e la lavorazione di bordi in alluminio non richiede levigatori e consente di ottenere una finitura sia lucida che opaca.

The technology developed by Stefani for aluminium edge processing doesn't require sanding units and allows you to obtain both shining and opaque finishing.

La tecnología desarrollada por Stefani para la aplicación y el trabajo de cantos de aluminio no pide alisadores y permite obtener un retoque tanto brillo como mate.

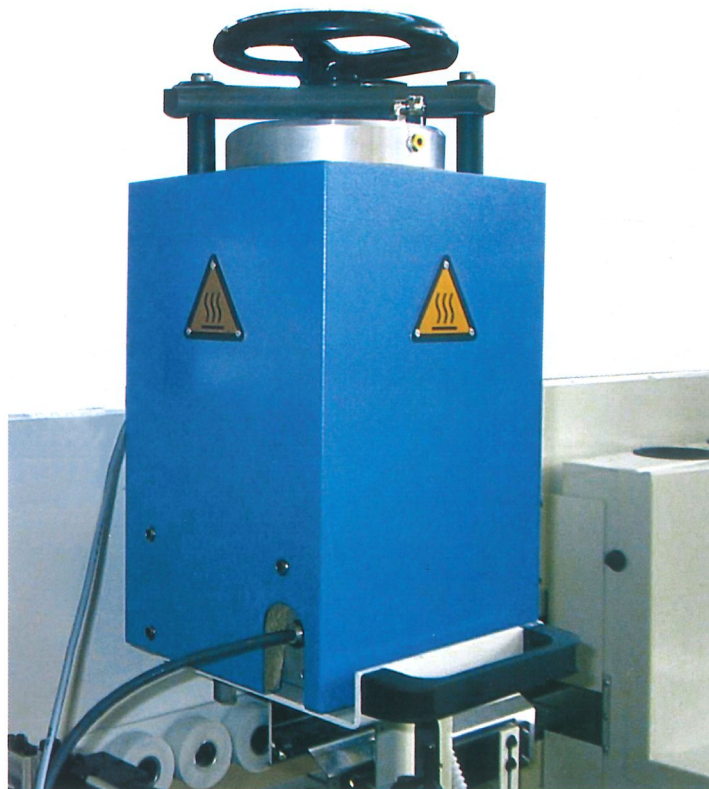

Kit applicazione colla poliuretana (PUR)

PUR glue process device

Kit aplicación cola poliuretánica (PUR)

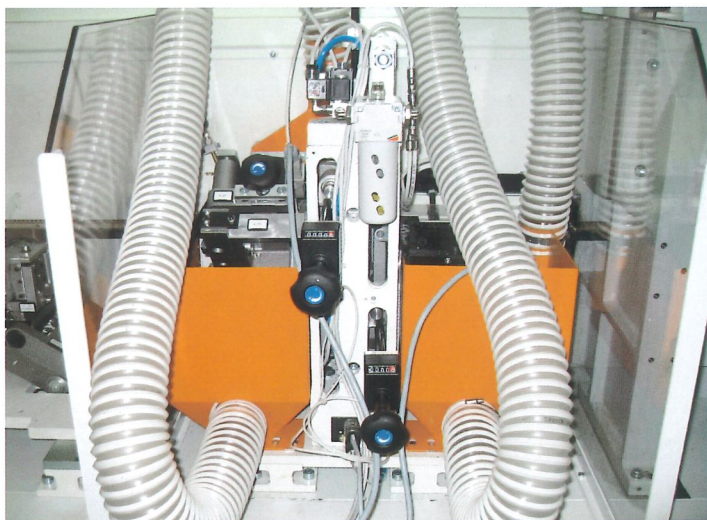

Gruppo finitore per alluminio

Finishing unit for aluminium edge

Grupo de retoque para aluminio



Gruppo spazzole per alluminio

Buffing unit for aluminium edge

Grupo cepillos para aluminio

Dati tecnici

Technical specifications

Características técnicas

Spessore minimo e massimo del bordo in rotolo	Minimum and maximum coil material thickness	Espesor mínimo y máximo del canto en rollos	0,3 - 3 mm
Spessore minimo e massimo del bordo in striscia (in funzione del gruppo incollaggio installato)	Minimum and maximum strip material thickness (in function of the fitted gluing unit)	Espesor mínimo y máximo del canto en tiras (segun el grupo encolado instalado)	0,3 - 12 mm (25 mm opt.)
Spessore minimo e massimo del pannello	Minimum and maximum panel thickness	Espesor mínimo y máximo del panel	10 - 60 mm
Larghezza minima del pannello (in funzione dei gruppi operatori montati)	Minimum panel width (in function of the fitted working units)	Ancho mínimo del panel (en función de los grupos operadores instalados)	215 mm
Larghezza massima del pannello (prima di linea)	Maximum panel width (first in line)	Anchura máxima del panel (primera en linea)	1600 mm
Larghezza massima del pannello (seconda di linea)	Maximum panel width (second in line)	Anchura máxima del panel (segunda en linea)	3200 mm
Interasse pioli	Dogs distance	Distancia fiadores	900 mm (opt. 500/400 mm Evolution SSB) 500 mm (opt. 400/300 mm Evolution SB)
Altezze pioli	Dogs height	Alturas fiadores	12-18-25 mm
Velocità di avanzamento variabile	Adjustable feed speed	Velocidad de avance variable	10-40 m/min (opt. 10-60 m/min Evolution SB) (opt. 10-70 m/min Evolution SB)

I dati tecnici possono variare in funzione della composizione scelta. Per esigenze dimostrative alcune foto riproducono macchine complete di accessori. Senza nessun preavviso i dati tecnici possono essere modificati, le modifiche non influenzano la sicurezza prevista dalle norme CE.

Technical specifications may vary according to the composition chosen. For demonstration purposes, several photographs show machines complete with accessories. The technical data can be modified without advance notice, the modifications do not influence the safety prescribed by the CE regulations.

Los datos técnicos pueden variar en función de la composición elegida. En este catalogo las máquinas han sido representadas con algunos accesorios. La empresa se reserva el derecho de modificar los datos y las medias sin previo aviso sin influir en la seguridad prevista de la certificación CE.

STEFANI

SINCERT



STEFANI

STEFANI

SCM GROUP spa - Via del Lavoro, 1/3 - PO Box 168 - 36016 Thiene (VI) - Italy
Tel. +39/0445/359511 - Fax +39/0445/359599 - www.scmgroup.com - stefani@scmgroup.com