

ANDREONI

www.hoechsmann.com

ANDREONI

**PANTOGRAFI SCOLPITORI
MULTIPLI MANUALI**

CARVING MACHINES - MACHINES À SCULPTER



Il presente catalogo illustra i nostri Pantografi Scolpitori Multipli Manuali.

I pantografi sono dotati di motori semplici o reversibili ed il bloccaggio dei pezzi può essere meccanico o pneumatico.

Su tutti i nostri pantografi si possono ottenere pezzi rotanti, piani e curvi ed ogni operazione di comando e manovra è della massima rapidità.

Per la sola lavorazione piana, i pantografi vengono costruiti con bancalle a bloccaggio meccanico o pneumatico.

This catalogue shows our Manual Multiple Pantograph Carving Machines.

Machines can be provided with simple or reversible motors and the locking of the pieces can be mechanical or pneumatic.

Our pantograph carving machines can work rotating, flat and curved pieces and each working and handling operation is made very quickly.

For flat pieces only, our pantograph carving machines are produced with mechanical or pneumatic table.

Ce catalogue illustre nos Sculpteuses Manuelles.

Les sculpteuses peuvent être livrées avec moteurs simples ou reversibles et le serrage des pièces peut être mécanique ou pneumatique.

Tous nos machines peuvent reproduire des pièces tournantes, planes et courbées.

Chaque operation de commande et manoeuvre est très rapide.

Pour la seule exécution des pièces planes, nos sculpteuses sont réalisées avec un plateau à serrage mécanique ou pneumatique.

POTENZA MOTORI
MOTORS POWER
PUISSANCE MOTEURS

HP 1,2 - 1,8
W 900 - 1300

12.000 e 18.000 giri al minuto
12.000 and 18.000 r.p.m.
12.000 et 18.000 t/minute

ERREDI 2 - 4 Mandrini/Spindles/Mandrins



ERREDI 2
Rotazione manuale dei pezzi
Manual pieces rotation
Rotation manuelle des pièces



ERREDI 2 
Rotazione manuale dei pezzi
Manual pieces rotation
Rotation manuelle des pièces



ERREDI 4
Rotazione manuale dei pezzi
Manual pieces rotation
Rotation manuelle des pièces



ERREDI 4
Rotazione elettrica dei pezzi
Electric pieces rotation
Rotation électrique des pièces



ERREDI PIANA
Solo per pezzi piani
For flat pieces only
Pièces planes seulement



TAVOLE LAVORAZIONE PIANA
Tavole acciaio rivestite in legno per lavori piani e curvi
Steel tables wooden covered for flat and curved pieces
Tables en acier, recouvertes de bois pour pièces et courbées

ERREDI è un piccolo pantografo particolarmente adatto agli scultori che eseguono pezzi di misure ridotte. Richiede poco spazio d'ingombro ed ha il vantaggio di essere particolarmente facile e leggero da usare, pur mantenendo le stesse prestazioni professionali dei modelli più grandi.

ERREDI is a small machine particularly suitable for wood-carvers who need to produce pieces of reduced sizes. **ERREDI** can be placed in a small room and has the big advantage to be easy and light to handle, keeping the same professional performances of the bigger machines.

ERREDI est une petite sculpteuse tout spécialement indiquée pour les sculpteurs qui ont l'exigence de produire des pièces de dimensions réduites. **ERREDI** demande peu de place et présente l'avantage d'être particulièrement facile et légère d'employer, en maintenant les mêmes performances professionnelles des machines plus grandes.

Lunghezza utile di lavorazione mm. 800 - Working length mm. 800 - Longueur utile de travail mm. 800

No.	Distanza Mandrini	Dimensioni	PESI - WEIGHT
	Spline distance		
	Distance mandrins	Dimensions	netto / net
	mm.	mm.	Kg.
2	450	1750 x 1600 x 1500	560
4	225		580

MEDIA 2 - 4 - 6 - 8 Mandrini/Spindles/Mandrins



MEDIA 2
 Motori semplici
 Simple motors
 Moteurs simples



MEDIA 4
 Motori reversibili
 Reversible motors
 Moteurs reversibles

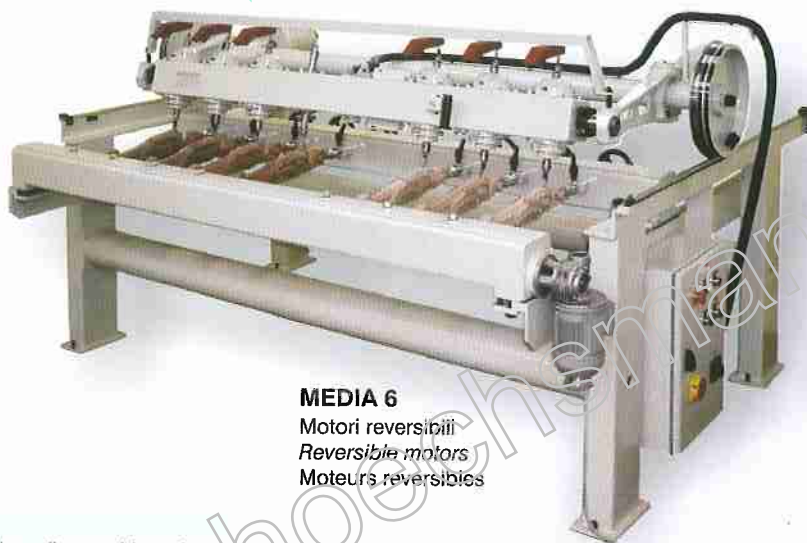

MEDIA 6
 Motori reversibili
 Reversible motors
 Moteurs reversibles

Questo tipo di macchina viene realizzato con lo scopo principale di diminuire l'ingombro e i costi mantenendo inalterate le prestazioni e le caratteristiche tecniche-professionali, del tipo Standard.

Lunghezza utile di lavoro mm. 1300 (a richiesta mm. 1500 - 1700).

This type of machine was developed with the main purpose to reduce encumbrance and costs, keeping unaltered the technical-professional characteristics and performances of the standard type.

The net working length is mm. 1300 (on request mm. 1500 - 1700).

Ce type de machine a été réalisé dans le but principal de réduire l'encombrement et les coûts, en gardant inaltérées les performances et les caractéristiques techniques-professionnelles du type Standard.

Longueur utile de travail mm. 1300 (à la demande mm. 1500 - 1700).

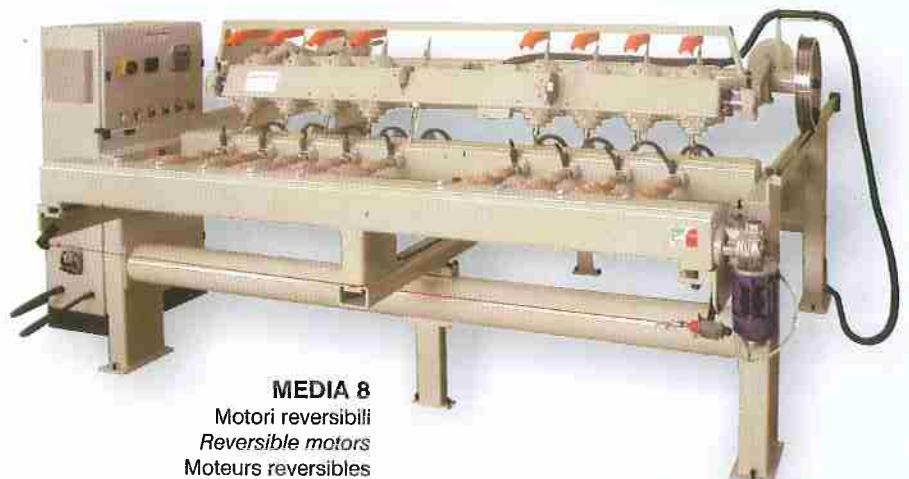

MEDIA 8
 Motori reversibili
 Reversible motors
 Moteurs reversibles

No.	Distanza Mandrini Spindle distance Distance mandrins	Dimensioni Dimension Dimensions	PESI - WEIGHT POIDS
	mm. max	mm. max	netto / net Kg.
2	450	2176 x 2200 x 1480	810
4	350	2676 x 2200 x 1480	980
6	250	2776 x 2200 x 1480	1085
8	220	3036 x 2200 x 1480	1190

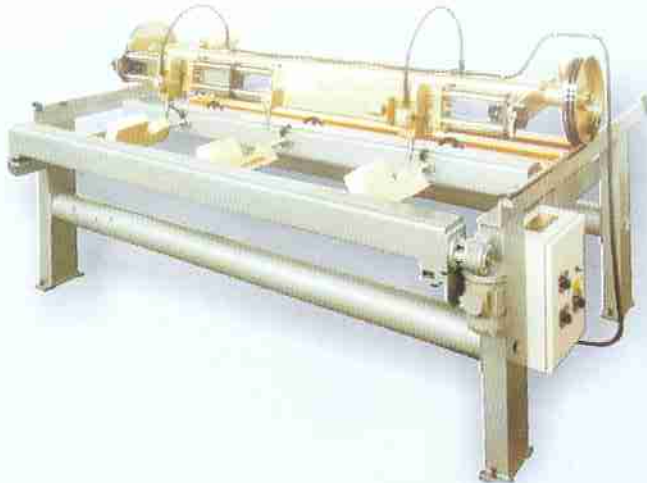
D+S**DESTRO + SINISTRO
LEFT + RIGHT
DROITE + GAUCHE****PANTOGRAFO SPECIALE
SPECIAL CARVING MACHINE
SCULPTEUSE SPÉCIALE****D+S 2 mandrini:**

senza apertura centrale
per la produzione di un pezzo destro e un pezzo sinistro,
copiando da un modello destro o sinistro

D+S 2 spindles:

without central opening
for production of one right piece and one left piece,
copying a right or left model

D+S 2 mandrins:

sans ouverture centrale
pour la production d'une pièce droite et un pièce gauche,
en copiant un modèle droit ou gauche

D+S 2 mandrini:
con apertura centrale
per la produzione
di un pezzo destro e un pezzo sinistro,
copiando da un modello destro o sinistro

D+S 2 spindles:
with central opening
for production
of one right piece and one left piece,
copying a right or left model

D+S 2 mandrins:
avec ouverture centrale
pour la production
d'une pièce droite et un pièce gauche,
en copiant un modèle droit ou gauche

**D+S 4 mandrini:**

per la produzione di due pezzi destri e
due pezzi sinistri, copiando da un modello
destro o sinistro

D+S 4 spindles:

for production of two right pieces and two left pieces,
copying a right or left model

D+S 4 mandrins:

pour la production de deux pièces droite et deux
pièce gauche, en copiant un modèle droit ou gauche



**ALCUNI ESEMPI DI LAVORAZIONE
SOME EXAMPLES OF CARVED PIECES
QUELQUES EXEMPLES DE PIÈCES SCULPTÉES**

No.	Distanza Mandrini Spindle distance Distance mandrins	Dimensioni Dimension Dimensions	PESI - WEIGHT POIDS
	mm.	mm.	netto / net Kg.
2	600	3520 x 3005 x 1520	1740
4	300	3520 x 3005 x 1520	1790

STANDARD

4 - 6 - 8 - 10 - 12 - 14 - 16 - 20 Mandrini/Spindles/Mandrins
Bloccaggio meccanico o pneumatico dei pezzi / *Mechanical or pneumatic locking of the pièces* / Serrage mécanique ou pneumatique des pièces



STANDARD 4
Motori reversibili
Reversible motors
Moteurs reversibles



STANDARD 6
Motori reversibili
Reversible motors
Moteurs reversibles



STANDARD 8
Motori reversibili
Reversible motors
Moteurs reversibles

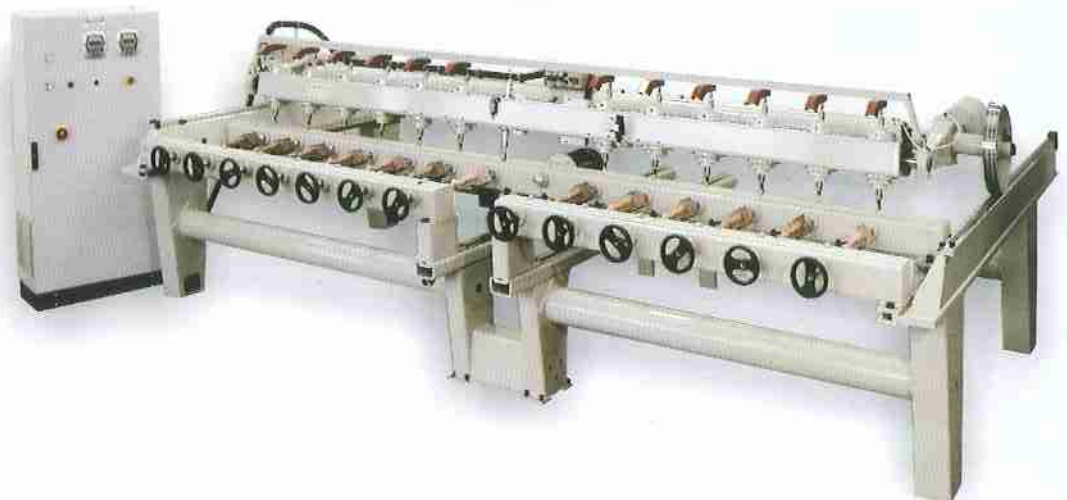

STANDARD 12
Motori reversibili
Reversible motors
Moteurs reversibles



STANDARD 16
 Motori reversibili
Reversible motors
 Moteurs reversibles

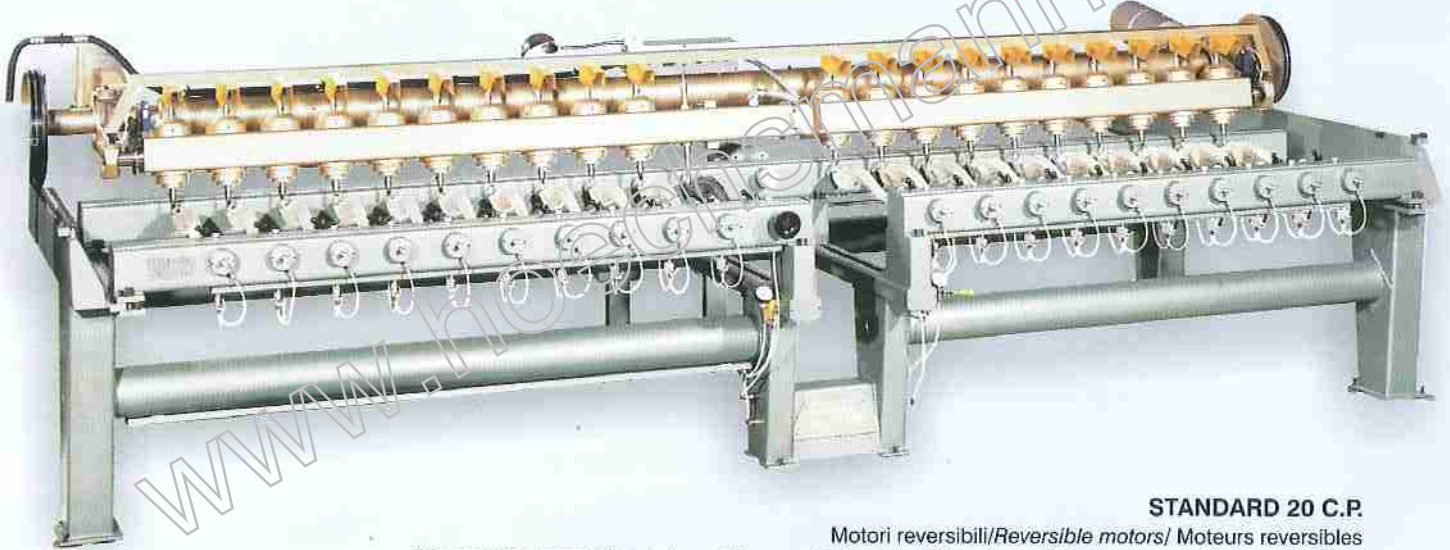

STANDARD 20 C.P.
 Motori reversibili/*Reversible motors*/ Moteurs reversibles
 Bloccaggio pneumatico dei pezzi/*Pneumatic locking of the pieces*/Serrage pneumatique des pièces

Lunghezza utile di lavorazione di mm. 1900 - Lunghezze maggiori a richiesta
Working lenght mm. 1900 - Longer size on request
Longueur utile de travail mm. 1900 - Longueur plus grande sur demande

No.	Distanza Mandrini	Dimensioni	PESI - WEIGHT
	<i>Splinde distance</i> Distance mandrins mm. max.	<i>Dimension</i> Dimensions mm. max	netto / net Kg.
4	600	3850x3150x1500	1900
6	600	5050x3150x1500	2050
8	450	5050x3150x1500	2150
10	350	4950x3150x1500	2210
12	300	5050x3150x1500	2260
16	250	5480x3150x1500	2400
20	200	5810x3150x1500	2700

STANDARD lavorazione PIANA

FLAT PIECES/PIÈCES PLANES

4 - 6 - 8 - 10 - 12 - 14 - 16 - 20
Mandrini/Spindles/Mandrins

STANDARD 10 PIANA

Motori reversibili
SOLO LAVORAZIONE PIANA
Bancale a bloccaggio meccanico dei pezzi
Reversible motors
FLAT WORKS ONLY
Table for mechanical locking of the pieces
Moteurs reversibles
PIÈCES PLANES SEULEMENT
Table pour le serrage mécanique des pièces

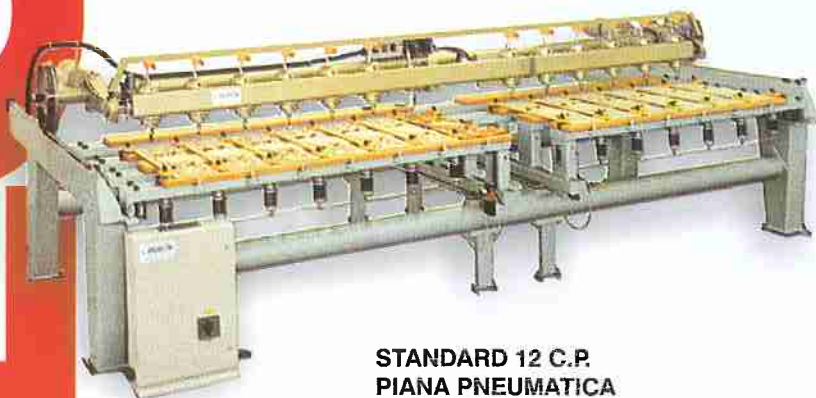

STANDARD 12 C.P. PIANA PNEUMATICA

Motori reversibili
SOLO LAVORAZIONE PIANA
Bancale a bloccaggio pneumatico dei pezzi
Reversible motors
FLAT WORKS ONLY
Table for pneumatic locking of the pieces
Moteurs reversibles
PIÈCES PLANES SEULEMENT
Table pour le serrage pneumatique des pièces



Bloccaggio meccanico o pneumatico dei pezzi
Mechanical or pneumatic locking of the pieces
Serrage mécanique ou pneumatique des pièces

Lunghezza utile di lavorazione mm. 2000 - Lunghezze maggiori a richiesta
Working length mm. 2000 - Longer size on request
Longueur utile de travail mm. 2000 - Longueur plus grande sur demande

ACCESSORI OPTIONAL DEVICE ACCESSORIES

Apparecchio posatore pneumatico
per la messa in posizione dei pezzi da lavorare
*Pneumatic instrument for the placement
of the pieces to work*

Dispositif pneumatique pour le positionnement
des pièces à sculpter



Tavole in acciaio
rivestite in legno
per lavori piani e curvi

*Steel tables
wooden covered
for flat and
curved works*

Tables en acier,
recouverts de bois,
pour pièces planes
et courbées



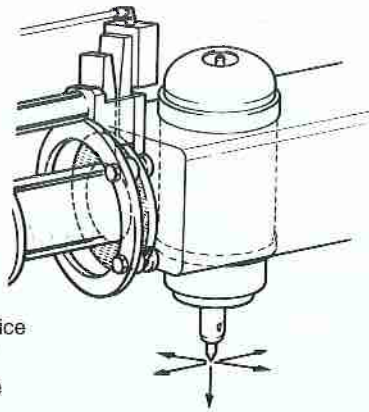

Motore semplice
Simple motor
Moteur simple

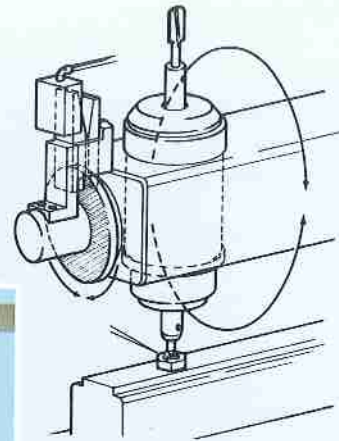

Motore reversibile
e freno a disco
a bloccaggio
pneumatico regolabile
Reversible motor
and presetting
disc brake for
pneumatic locking
Moteur reversible
et frein à disque
reglable à
serrage pneumatique

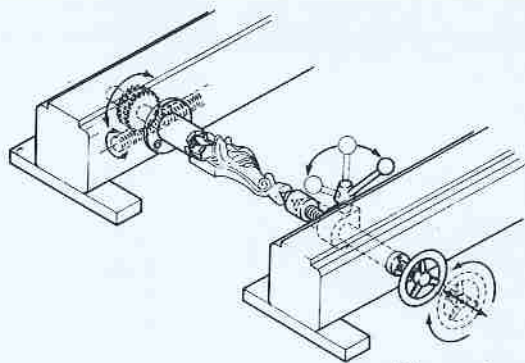

Bloccaggio meccanico
Mechanical locking
Serrage mecanique

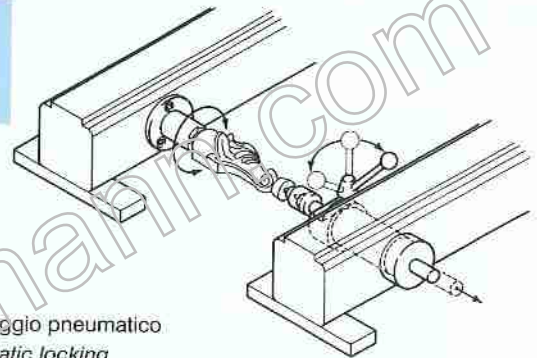

Bloccaggio pneumatico
Pneumatic locking
Serrage pneumatique

UTENSILI PER PANTOGRAFO SCOLPITORE con attacco Ø 11 mm.
CARVING TOOLS FOR PANTOGRAPH CARVING MACHINE - beam Ø 11 mm.
MÈCHES POUR SCULPTEUSES - attache Ø 11 mm.



Freccia
Lance
15° - 30°



Cucchiaio
Spoon
Ø 14-16-18



1 Tagliante tondo
1 Round cut
Ø 4-6-8-10-12-14-16-18



2 Taglienti tondi
2 Round cuts
Ø 14-16-18-20-22-24



1 Tagliante piano
1 Flat cut
Ø 4-6-8-10-12



2 Taglienti piani
2 Flat cuts
Ø 14-16-18-20

RECINZIONE PER NORME 

GATE  RULES

ENCEINTE POUR NORMES 

IMBALLO PER L'ESPORTAZIONE:
casse in legno
EXPORT PACKING: wooden cases
EMBALLAGE POUR L'EXPORTATION:
caisses en bois



ESEMPI DI LAVORAZIONE *EXAMPLES OF CARVED PIECES* *EXEMPLES DE PIÈCES SCULPTÉES*

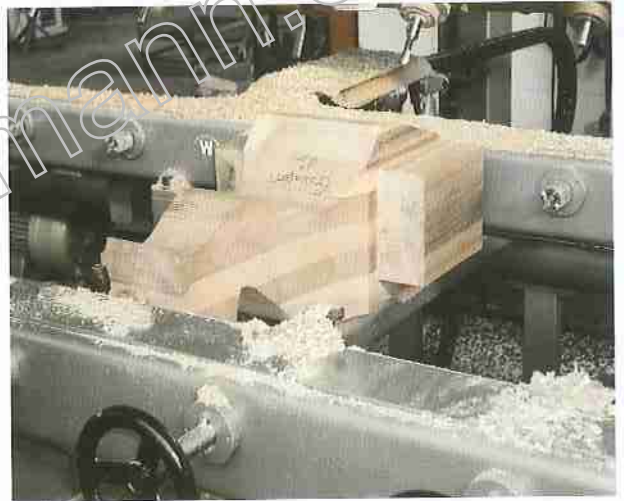

ESEMPI DI LAVORAZIONE

EXAMPLES OF CARVED PIECES

EXEMPLES DE PIÈCES SCULPTÉES

