

More stable. More intelligent. More flexible.

# ARCUS 1334 | 1336



PRODUCTIVITY AND PRECISION



# The New Top Class with Superior Performance

Higher performance, greater stability, as well as a machine design to set accents – the ARCUS from HOLZ-HER redefines edgebanding machines. The ARCUS classic, massiv, automatic, premium, grooving and sanding models all have a heavy duty industrial transport chain as a standard feature. The large, motor-driven pressure unit, the end trimming unit with linear guides as well as the extremely stable scraper – also with motor control – are all included as standard features. This ensures that the right machine is available for every application. The pressure bridge with rollers is a standard feature. As an option it can be equipped with belt bridge for particularly smooth transport of the workpiece.

- Exceptional stability – welded base frame design.
- NOW NEW: Machine extension
  - 660 mm in entry area for up to three glue application systems attached in parallel as well as optimized feed angle.
  - 270 mm in finishing area for new equipment versions.
- NOW NEW: Heavy duty industrial chain
  - Standard feature on all ARCUS models. For guaranteed vibration-free and smooth transport of the workpiece.
- Economical – locking roller for minimum workpiece interval, workpiece detected by light barrier.

## ECO Mode

Intelligent energy management for HOLZ-HER edgebanders.

## SYNCHRO

For short workpiece intervals and optimized edge protrusions.



Illustrations may contain optional features.

## Simple handling – high productivity

### ■ Guide system

For optimum guidance of narrow workpieces. The guide system moves along with the workpiece at a 90 degree angle right up to secure transfer to the machine (optional) (Fig. 1).

### ■ Radius scraper

Heavy duty upright unit – scraper with motorized adjustment for optimum adaptation to existing edge tolerances (Fig. 2).

### ■ Air cushion table

For easy and careful handling – even with bulky workpieces (optional) (Fig 3).

### ■ 6-position edge feeder

New with sensor for recognition of remaining length and automatic change-over to alternative edging channel. Including auxiliary channel for feeding in cut-length edging strips (optional) (Fig. 4).

### ■ Nesting package

For concealed hinge holes or trapezoidal workpieces (optional) (Fig. 5).

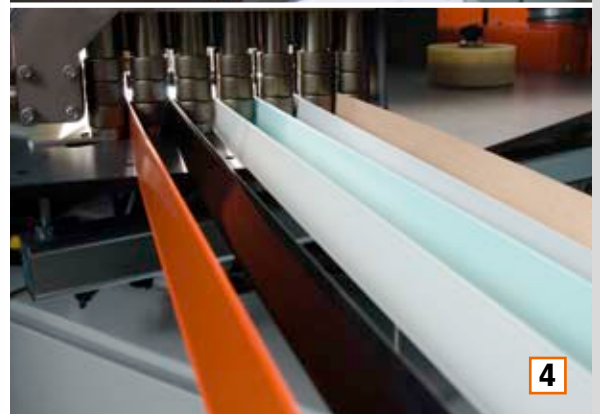

1

2

3

4

5

# High standards guarantee your investment for the future

The HOLZ-HER Edge Control PPC 221 and PPC 231 provide extremely high performance making them a paragon for simple operation. A high-end industrial PC is used. Set-up and conversion of the machine has never been so rational.

## Monitor

- VGA color monitor PPC 221 (standard) or 15"-Touch-screen PPC 231 (optional).
- Graphic user interface, all information displayed in plain text and/or graphic form.

- Simple operation – rotating and swiveling control panel at eye height (Fig. 1 top right).
- Dust-proof foil keypad – protects PC for long service life.
- LED display for unit selection.

## Program list

- Programs are simple to call with program names and numbers.
- Large program memory for all desired applications.
- Individual selection of units with the functions as basic setting possibilities for nominal values, path points and tool corrections.
- Set-up processes for units and their axis settings carried out centrally and clearly by fine adjustment to 1/100 mm (depending on equipment).

## Integrated path control

- Interval display for shortest workpiece distance.
- Path points are controlled generally or in a program-specific manner.
- Clear and complete acquisition of all operating data: Total running meters, total number of parts, total number of hours, as well as running meters, quantity and time per program with reset function.
- Service reports in plain text.
- Integrated synchronous bus system for high accuracy in controlling the units.
- Individual management for up to ten users with password protection and individual authorization.

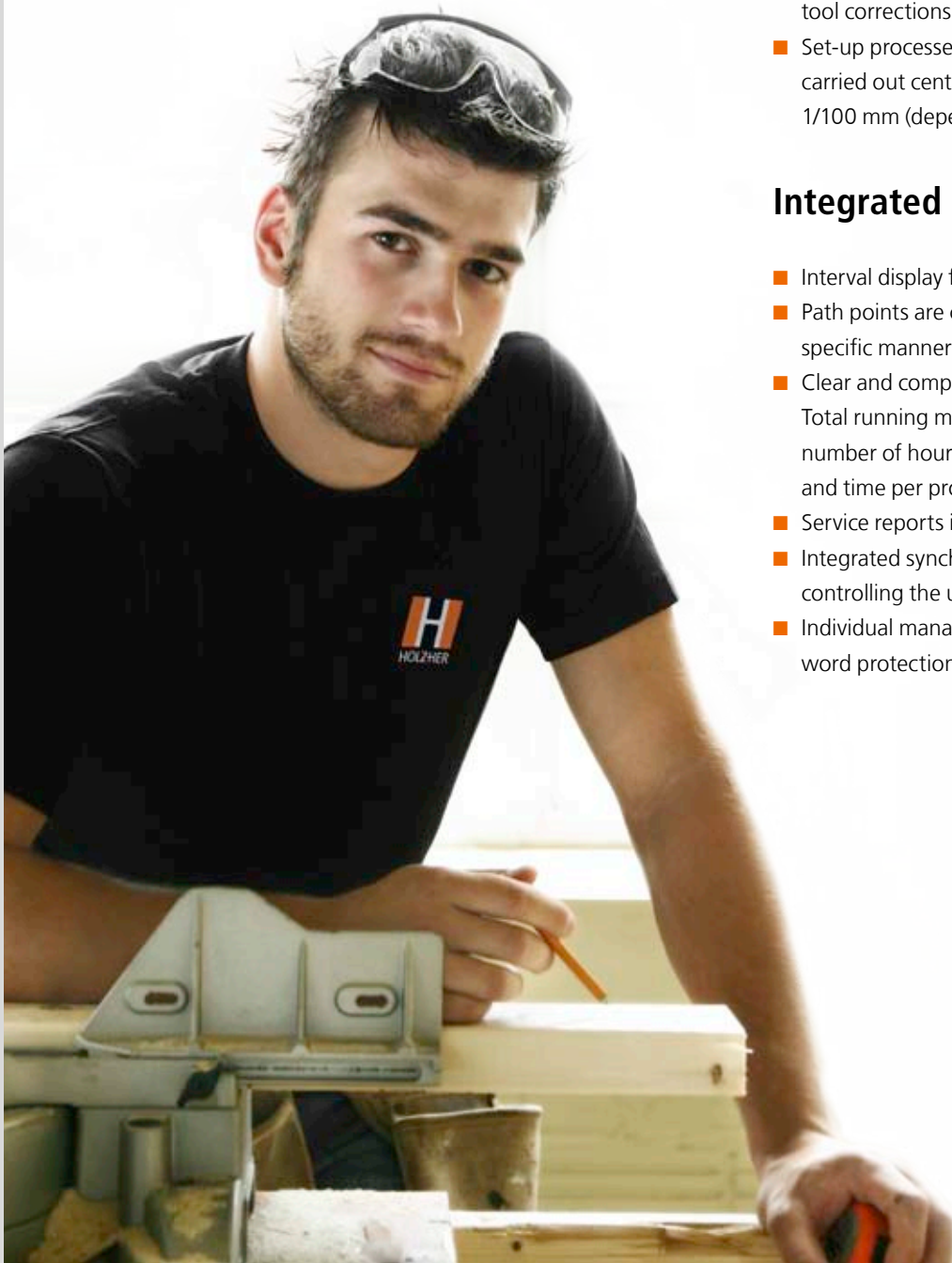

## Equipment/Service

- Network connection (optional).
- Online maintenance (optional), rapid exchange of data with HOLZ-HER service department.
- Barcode interface (optional).
- Connection to HOLZ-HER process data management (HHPDE) system for direct read-out of operating data.

Electronically controlled setup processes with accuracy of 1/100 mm

PPC 231 Edge Control with 15"-Touchscreen (optional).

1

## Highly efficient production through HOLZ-HER machine network Programming – Sawing – Edgebanding – CNC Machining

### CabinetControl (1)

- Carcass furniture at the click of the mouse.
- Automatic generation of cutting lists and CNC programmes.

### Perfect data flow (4)

- Program information also via data matrix barcode.

### Rational and precision sawing (2)

- Perfect cutting results.
- Mature optimization software.
- Optimum sawing cycle.

### Effective CNC performance (5)

- Automatic program call with barcode.
- Variable programming with CAMPUS Software.
- Perfect cutting results.

### Intelligent edgebanding (3)

- Program selection at the press of a button.
- Alternative: fully automatic with barcode.

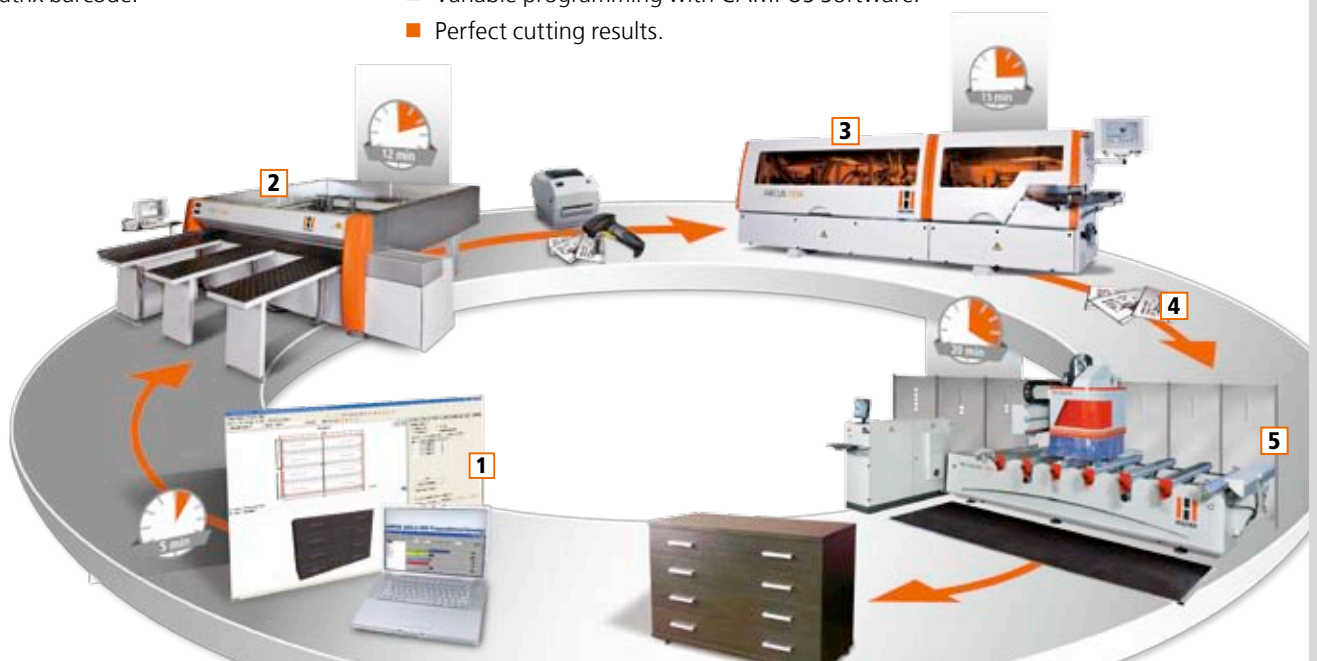



## GLUE APPLICATION SYSTEM

# Hybrid technology – two perfectly combined systems

The edgebander is decisive for furniture with a high quality appearance. You can also profit from 45 years of HOLZ-HER technological leadership in edgebanding.

- Change over from colored to neutral glue at the flick of the wrist.
- Cartridge or granular form (Figs. 1 and 2) – the glue can be changed over in minutes.
- Changeover from EVA to PUR glue is also possible within the shortest time.
- And the entire system can also be completely cleaned in just a few minutes.

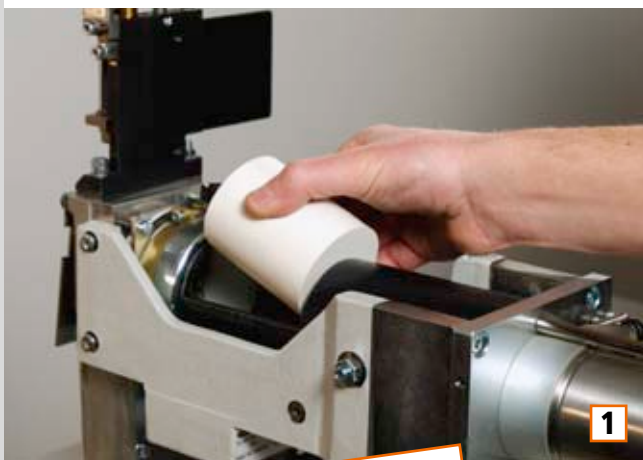

Heat-up time only 3 minutes



# Glu Jet – Zero joint with thin film technology

Ultra-thin glue joints, easily equivalent to industrial laser edges, are easy to achieve with the HOLZ-HER **Glu Jet** System, which also offers unrivaled flexibility.

The clear advantages of the hybrid technology in combination with the new HOLZ-HER thin film technology, make this gluing system the all rounder for craftsmen and industrial users. Visual zero joints with PUR glue – allowing use in wet area – are only natural for HOLZ-HER customers.

Reliability, quality and experience – backed up by HOLZ-HER's three year warranty on its patented **Glu Jet** nozzle system.

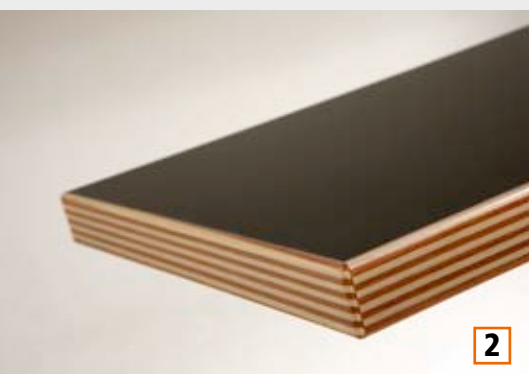
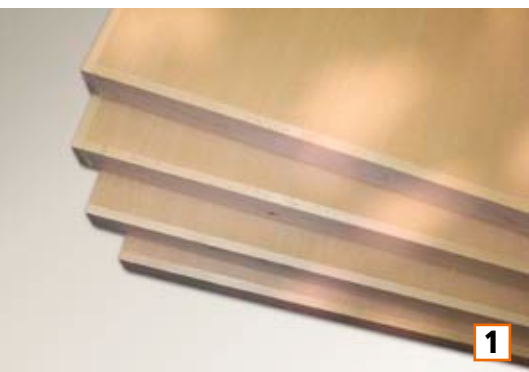
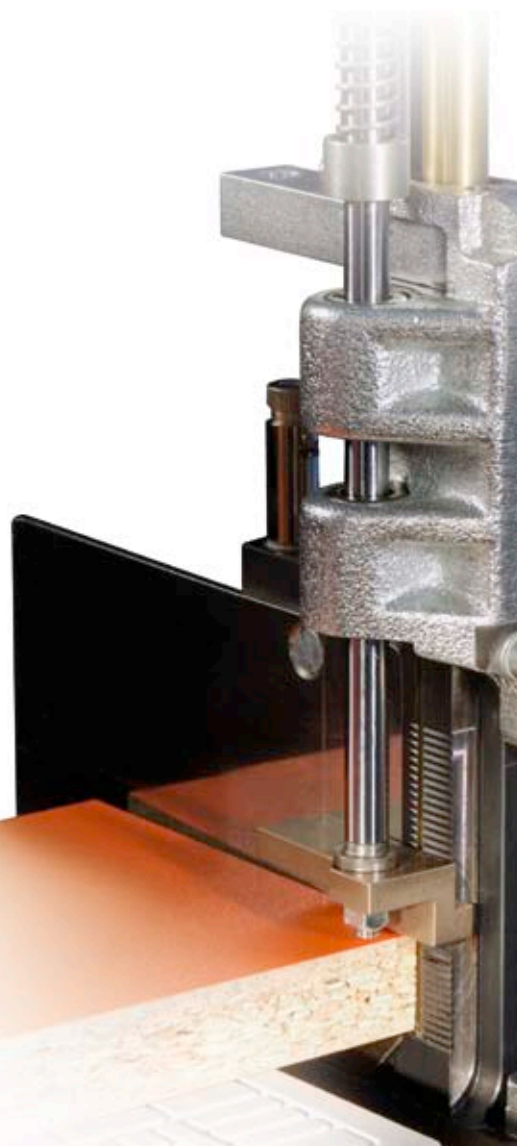

## Superior appearance on all materials

Starting with the state-of-the-art high gloss edging right up to solid wood edging with cross section of 20 x 65 mm, HOLZ-HER remains unequalled for variety.

HOLZ-HER sets the trends for tomorrow today.

- Solid wood edging (Fig. 1)
- Veneer edging
- Plastic edging (Fig. 2)
- Aluminum edging
- Formica edging
- Melamine resin edging
- and many others

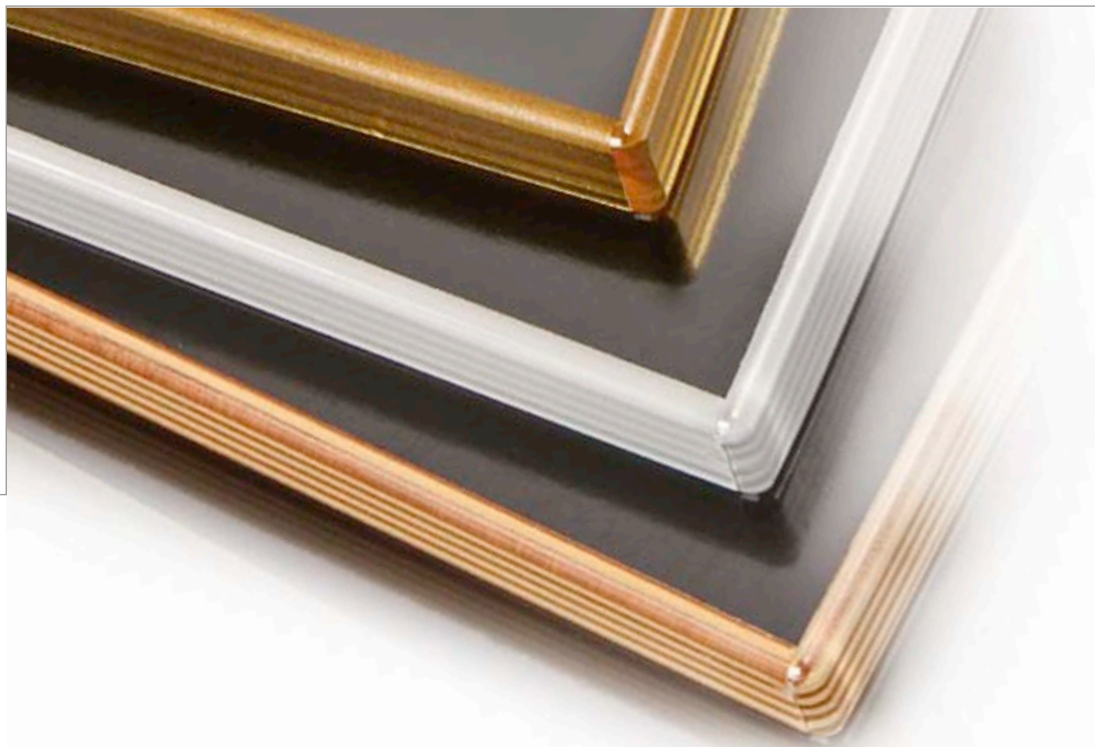

Perfect attachment of various edging materials.

## High tech for perfect edges

Over 30 high performance units are available to adapt the ARCUS series exactly to your work profile. Every one of these units is laid out for high continuous stress. Pneumatic and motor-controlled versions are available for a series of units. The stable transport chain runs on precision guides transporting the workpieces through the machine securely and accurately with gentle surface pads.



**Clean joints and finishing on high gloss edging**







## Premilling

With new symmetrical diamond cutters (dia. 100 mm) for maximum joint quality and long tool life. Automatic height adjustment with two NC servo-axes (optional).

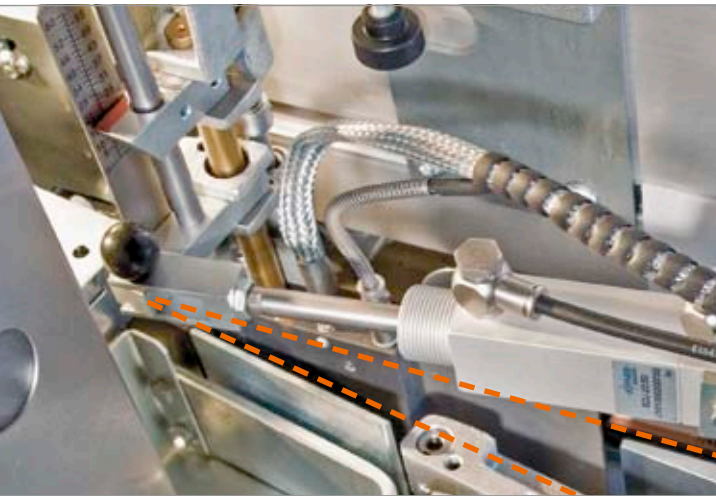
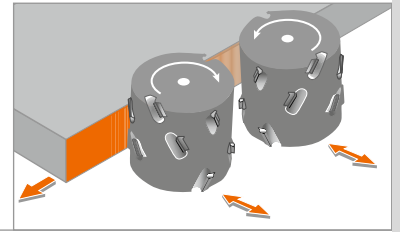

## Edge feeder SYNCHRO

The new edge feeder with SYNCHRO drive. The new Synchro magazine with its synchronous adaption to the feed speed guarantees short intervals between workpieces and simultaneously optimizes edging protrusions.

Small feed angle thanks to nozzle design – no problems feeding solid wood edging.

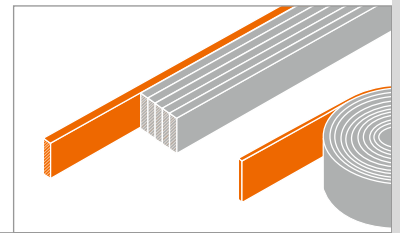

## Motor-driven pressure unit

Synchronously driven pressure unit with automatic adaptation to feed speed and NC servo-axes for motor-driven adjustment to correct edge thickness.

Straight and conical pressure rollers for perfectly glued joints.

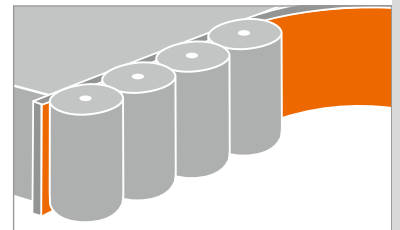

## End trimming unit

For workpiece thicknesses up to 80 mm (optional). Now with hardened linear guides for high precision end trimming results for edge thicknesses up to 20 mm.

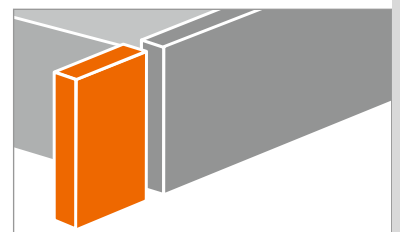

## Convincing cutting results up to edge thickness of 20 mm



### Flush cutting unit

High performance cutting unit for edge thicknesses up to 15 mm. Two NC servo-axes for cutting with and without edge protrusion (optional).

20 mm edge thickness standard feature on ARCUS sanding.

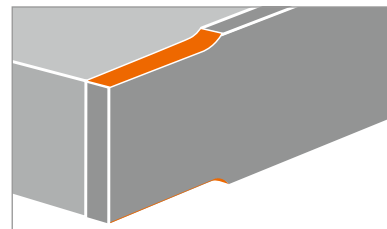

# Multi-function cutting technique at highest level

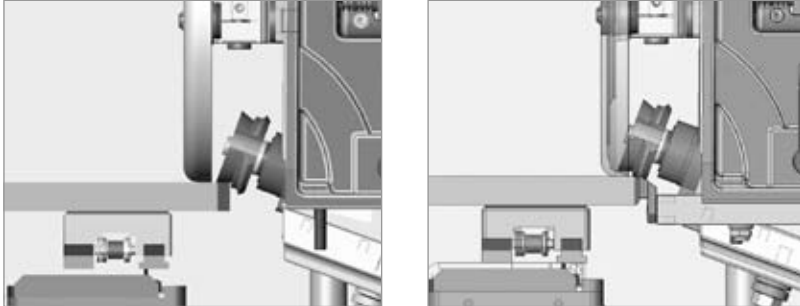

Copying near the joint and moving fully automatically with multi-function tools – perfectly combined with HOLZ-HER cutting technology.



## Multi-function cutter unit

For flush, radius and chamfer cuts including diamond tipped cutters with chip-optimized CM technology.

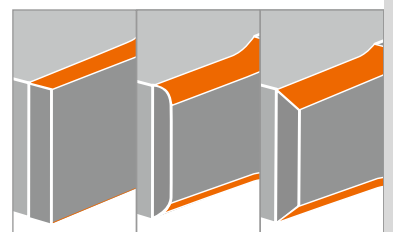

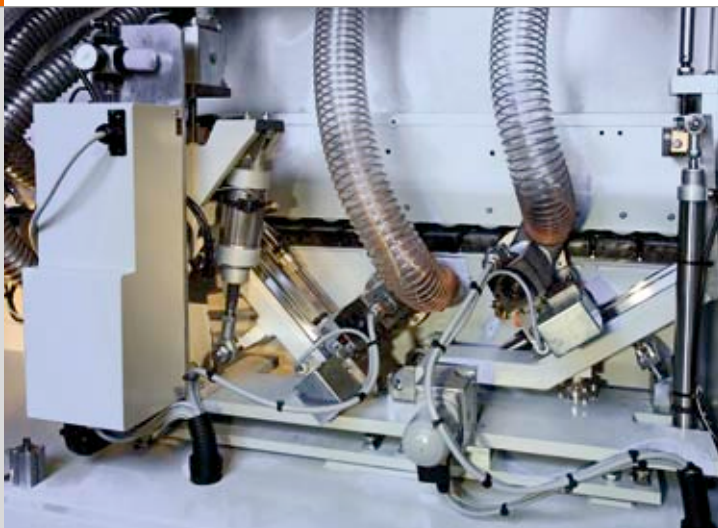

## Profile cutter unit

Profile cutter unit for corner rounding. Machining with two cutter motors for wide variety of postforming profiles. Standard equipment included four NC servo-axes as well as two diamond cutters with CM technology and ProLock quick change chuck. Maximum workpiece thickness 60 mm.

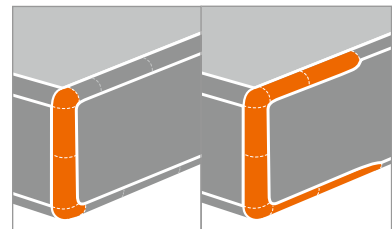

### ■ Pendulum sensor

Automatic pendulum sensor copies the face sides without material protrusion and leaves the optimum edge protrusion for the longitudinal edge for subsequent machining with the scraper unit.

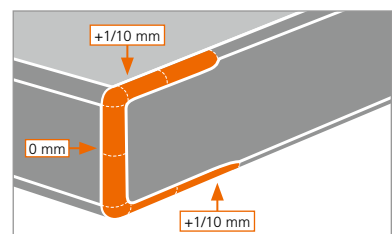

## Grooving unit

Optimum chip removal with groove cutter running in opposite direction. With two NC servo-axis for groove depth adjustment as well as groove position above control panel as standard feature. Pivots 0 – 90 degrees including grid holes at increments of 11.25 degrees. Including plunge control.

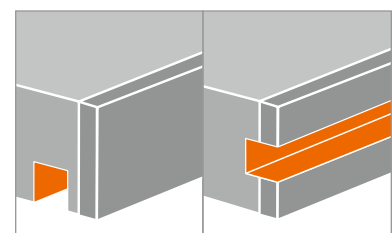

## Oscillating sanding

NEW: Oscillating sanding unit with NC servo-axes on ARCUS 1336 sanding. The perfect finish for your solid wood or veneer edging.

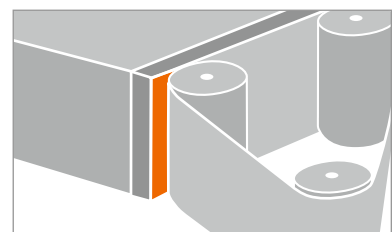

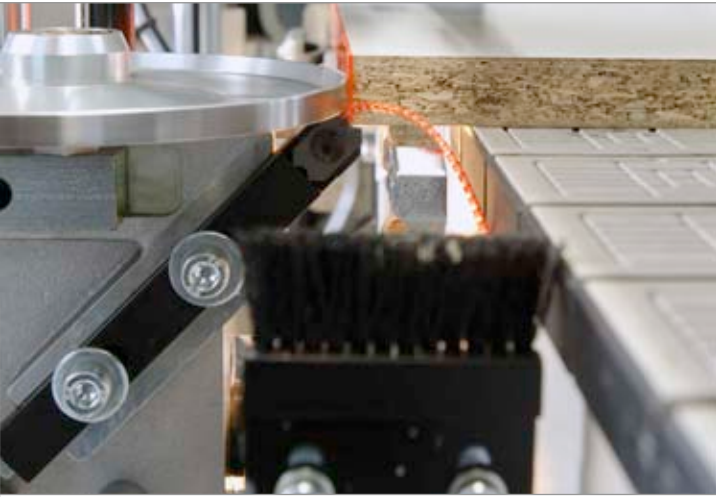

## Scraper unit

Heavy duty upright unit – motor driven horizontal adjustment with NC servo-axes – accuracy in 1/100 mm range. Also available as fully automatic version with five motor-driven adjustment axes (optional).

Motor-adjustable scraper for optimum adaptation to existing edging tolerances.

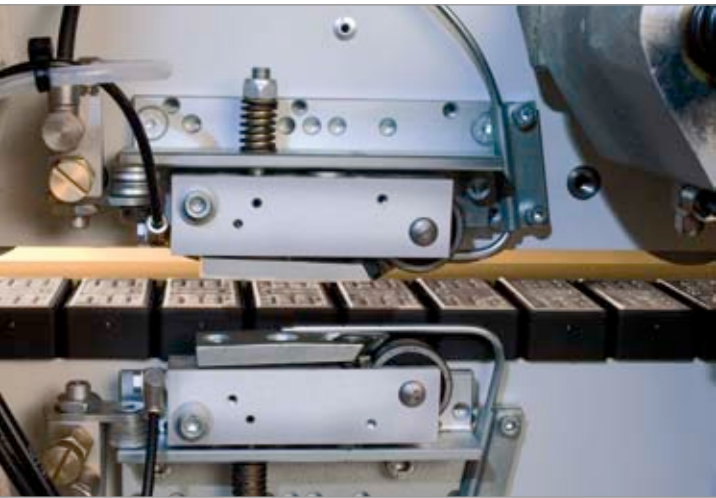
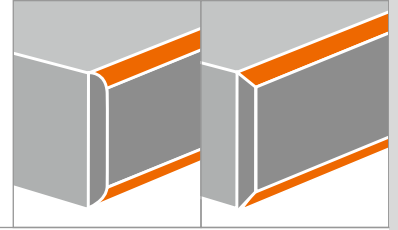

## Glue scraper

Clean finishing of surface – application controlled with two HW reversible blades – eliminates manual finishing. Installed as standard feature (not on ARCUS sanding).

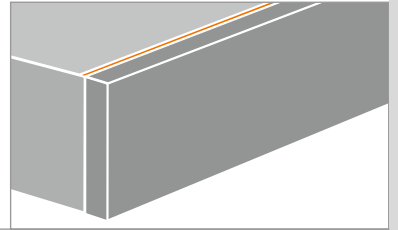

## Spraying devices

Spraying units for parting agents and cleaning agents for entry and finishing area. Anti-static, coolant and lubricant – electronically controlled by special nozzles – for a perfect edge finish. The various fluid reservoirs are all integrated cleanly into the machine frame.

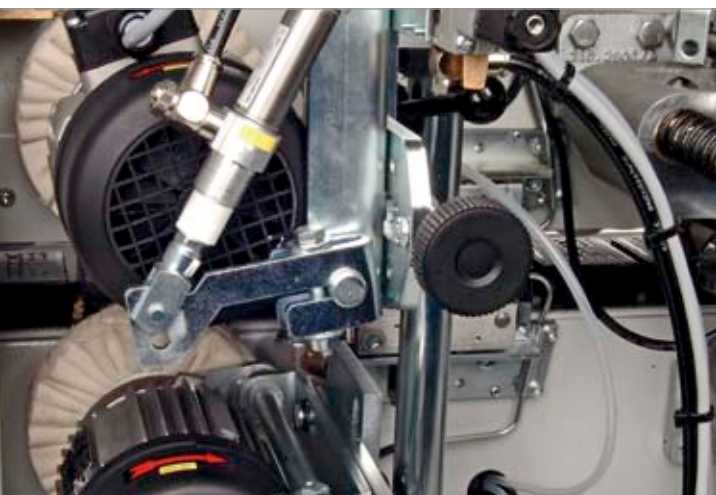
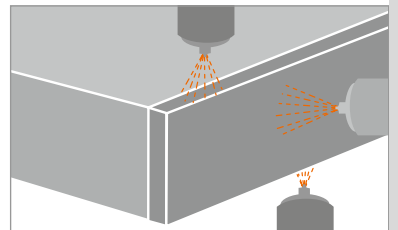

## Buffing units

For final finishing on edges and flat surfaces. Application controlled and alternatively oscillating (optional)

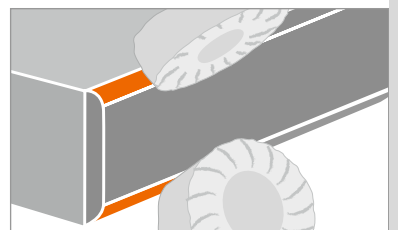

# Overview of ARCUS series

Machine	ARCUS 1334 classic	ARCUS 1334 massiv	ARCUS 1334 automatic	ARCUS 1336 premium	ARCUS 1336 grooving	ARCUS 1336 sanding	Options
Control	PPC 221	PPC 221	PPC 221	PPC 221	PPC 221	PPC 221	Touchscreen
Bridge	Roller bridge	Roller bridge	Roller bridge	Roller bridge	Roller bridge	Roller bridge	Belt bridge
Edge feeder	SYNCHRO	SYNCHRO	SYNCHRO	SYNCHRO	SYNCHRO	SYNCHRO	6-position edge feeder
Premilling	64 mm	64 mm	64 mm	64 mm	64 mm	64 mm	64 mm MOT 2, ø 100 mm
Glue application							Glue roller
Glue application	<b>Glu Jet</b> automatic	<b>Glu Jet</b> automatic	<b>Glu Jet</b> automatic	<b>Glu Jet</b> automatic	<b>Glu Jet</b> automatic	<b>Glu Jet</b> automatic	
Glue application							PU unit (2 kg cartridge) incl. <b>Glu Jet</b>
Pressure unit	4 motor-driven rollers	4 motor-driven rollers	4 motor-driven rollers	4 motor-driven rollers	4 motor-driven rollers	4 motor-driven rollers	
End trimming	Two-motor	Two-motor	Two-motor	Two-motor	Two-motor	Two-motor	
Cutting 1	Multi-fun.8 mm	Flush 15 mm	Multi-fun. 8 mm	Flush 15 mm	Multi-fun. 8 mm	Flush 20 mm	+ MOT versions
Cutting 2	x	x	x	Multi-fun. 8 mm	x	x	
Profile cutting	45 mm	60 mm	60 mm	60 mm	60 mm	60 mm	
Scraper	MOT	MOT	MOT	MOT	MOT	MOT	MOT 5
Glue scraper	Application controlled	Application controlled	Application controlled	Application controlled	Application controlled	Application controlled	
Buffing						On request	Application controlled Oscillating
Grooving		x	x	x	MOT 2	x	MOT 2
Sanding	x	x	x	x	x	Oscillating MOT 1	

	Optional
	Standard
x	Not possible
	Free space



## TECHNICAL DATA

	ARCUS 1334 classic	ARCUS 1334 massiv	ARCUS 1334 automatic	ARCUS 1336 premium	ARCUS 1336 grooving	ARCUS 1336 sanding
<b>Machine dimensions</b>						
Overall length (mm)	6,212	6,212	6,212	6,851	6,851	6,851
Weight (kg)	2,560	2,560	2,560	2,690	2,690	2,690
<b>Feed speed</b>						
Feed speed (m/min)	10 – 18	10 – 18	10 – 18	10 – 18	10 – 18	10 – 18
<b>Working dimensions</b>						
Minimum workpiece length (mm)	140	140	140	140	140	140
Minimum workpiece width (mm)	60	60	60	60	60	60
Workpiece thickness (mm)	6 – 60 (80)	6 – 60 (80)	6 – 60 (80)	6 – 60 (80)	6 – 60 (80)	6 – 60 (80)
Edge thickness (mm)	0.4 – 8 (15)	0.4 – 15	0.4 – 8 (15)	0.4 – 15	0.4 – 8 (15)	0.4 – 20

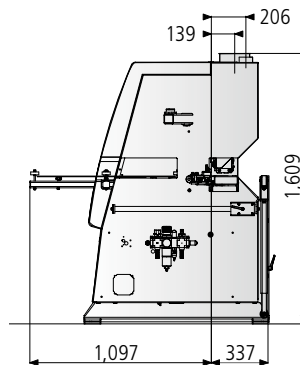
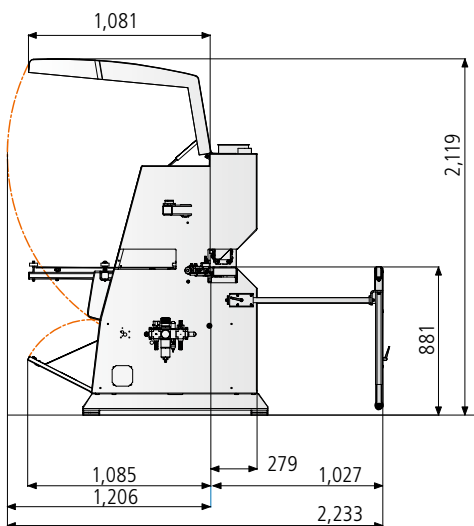

**Optional features:  
Workpiece  
thickness 80 mm**

## High Quality Details

- Standard noise control – to reduce noise at the machine (Fig. 1).
- Generously dimensioned handles make hoods easier to open (Fig. 2).
- Roller tracks in entry and finishing area (Fig. 3) – eliminate scratches on sensitive surfaces.

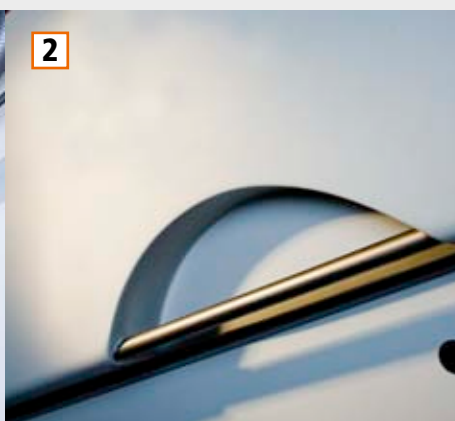

Product brochures and many  
videos are available at  
[www.holzher.com](http://www.holzher.com)



The technical data specified is intended for reference only. HOLZ-HER woodworking machines are subject to constant development and are therefore subject to modification without prior notice. The illustrations are therefore not binding. Some of the machines shown also contain special equipment not included as a standard feature. For clarity, some of the machines are shown without protective hood.

Picture credits: © istock | lisegagne

**UK** – HOLZ-HER 3126 25 – Printed in Germany  
Printed on: 23.04.2012 – First edition: 12.03.2012

Your authorized HOLZ-HER dealer



**HOLZ-HER GmbH**  
D-72622 Nürtingen

Tel.: +49 (0) 70 22 702-0  
Fax: +49 (0) 70 22 702-101  
[www.holzher.com](http://www.holzher.com)