

Processing centres BAZ 300

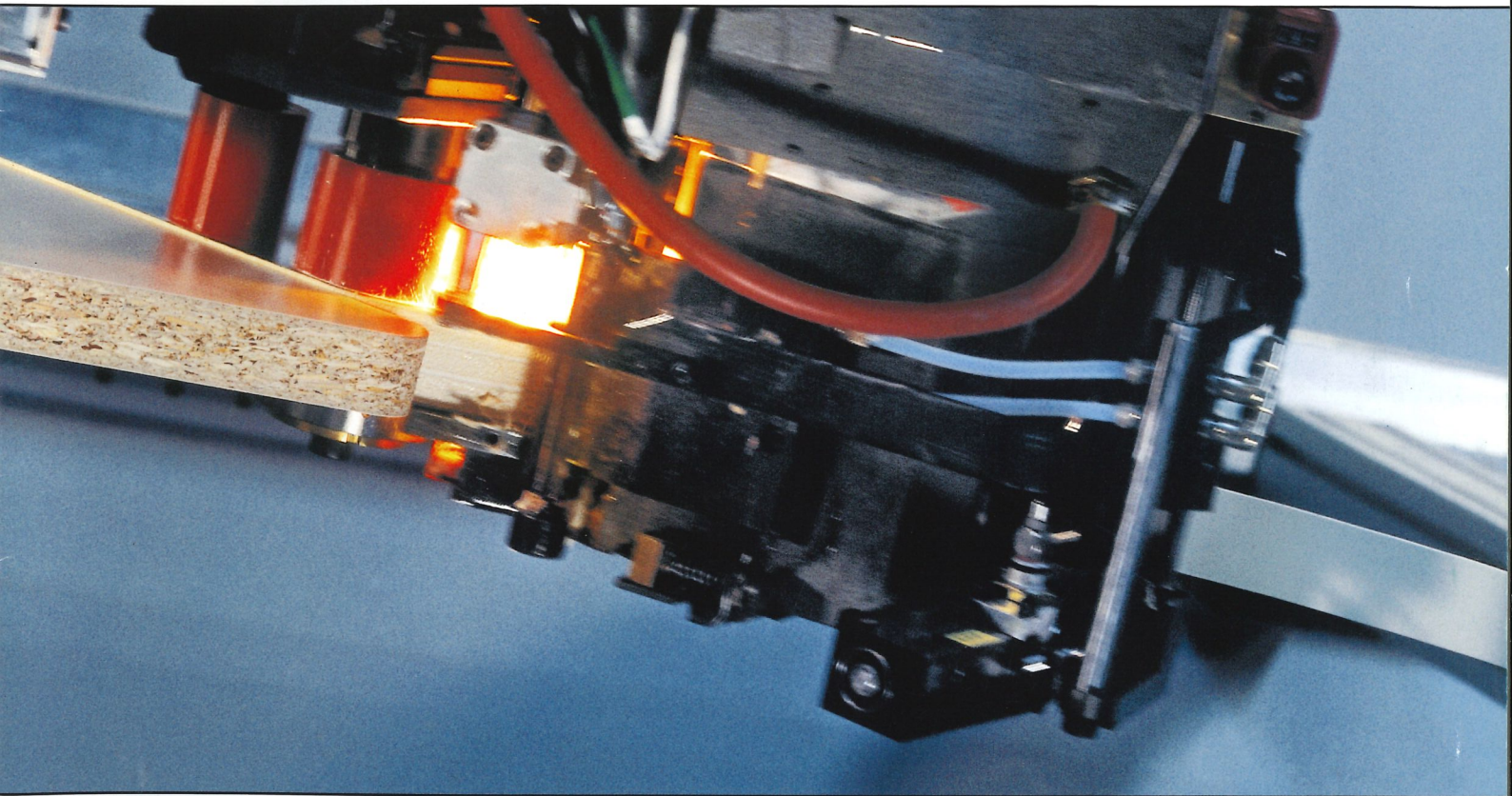

Optimat | profi line | power line





The BAZ 300 series: The processing center for every challenge

Incredible flexibility

Producing office furniture components today, store fixture components tomorrow, a solid wood staircase part the day after – all in a day's work for the BAZ 300 processing centre series. Its outstanding benefit lies in the combination of heavy duty routing and edge banding machine. Its comprehensive range of supplementary units, tried and tested over decades in tough industrial operation, will allow you to complete any order in record time and in outstanding quality.

From practical experience for practical application

Routing, profiling, drilling, grooving, edge banding or panel dividing – all with a single machine concept which allows you to simply purchase the units when you actually need them. The BAZ 300 series processing centres allow perfect processing of every kind of material: particleboard, MDF, core-board, solid wood and much more.

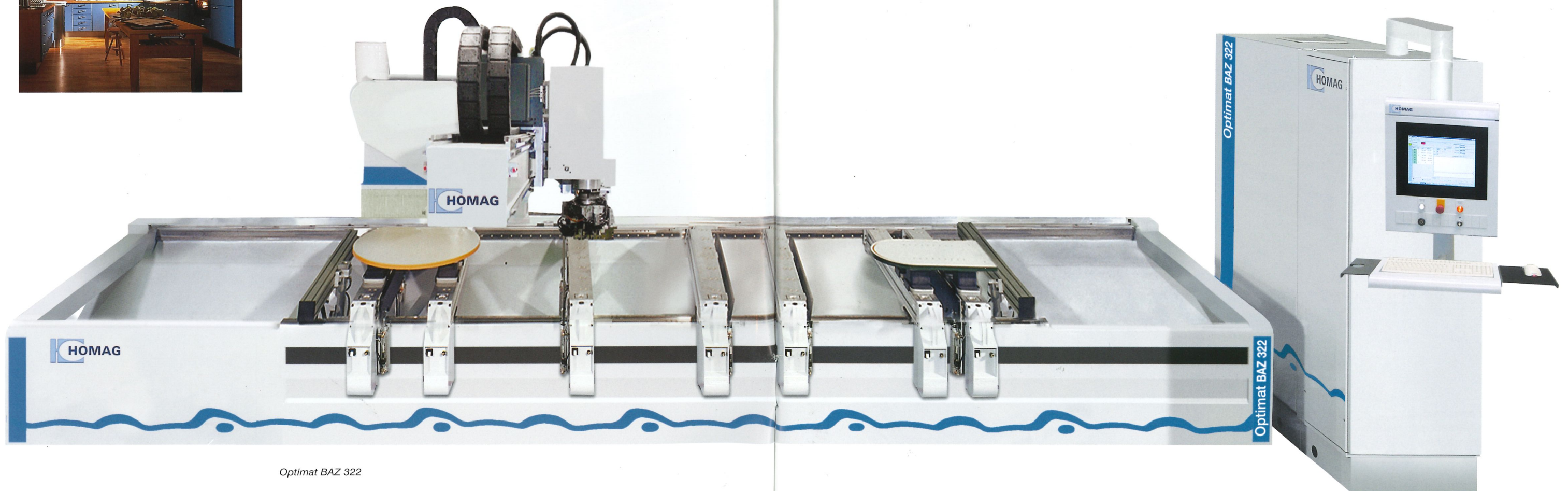

Optimat BAZ 322

That vital step ahead: Quality and design

Future and investment security

The BAZ 300 series processing centres provide the ultimate answer to your production requirements. Your benefits at a glance:

- A machine concept capable of replacing several individual machines, with one complete and space-saving solution
- Future purchase of additional work units as your business grows, will ensure profitable use for many years to come
- Profitable even for producing small batch sizes
- Manufacturing with improved quality and less scrap, as workpieces can be processed on one machine – cutting down on transport damage between the individual work steps
- The gluing unit can either be a ride along unit that is changed into the main spindle automatically (BAZ 311) or is mounted on the working beam with its own Y-axis (BAZ 322)
- Efficient 2-channel technology (BAZ 322): While gluing is taking place on one side of the working beam, on the other side of the working beam the next needed tool is being changed ready for the next operation



Scraper blade processing with the traced combination flush trimming and scraping unit

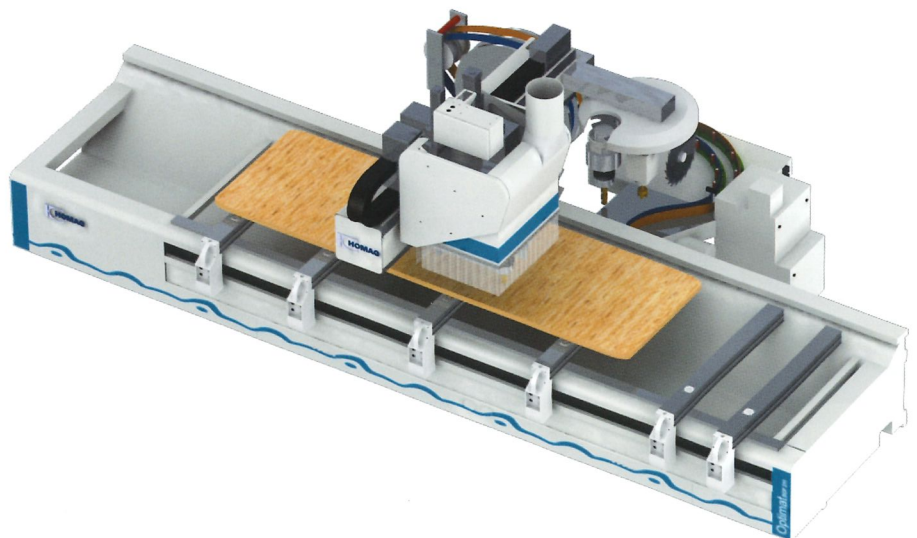

Individual processing

For large workpieces, the entire length of the machine table is used.

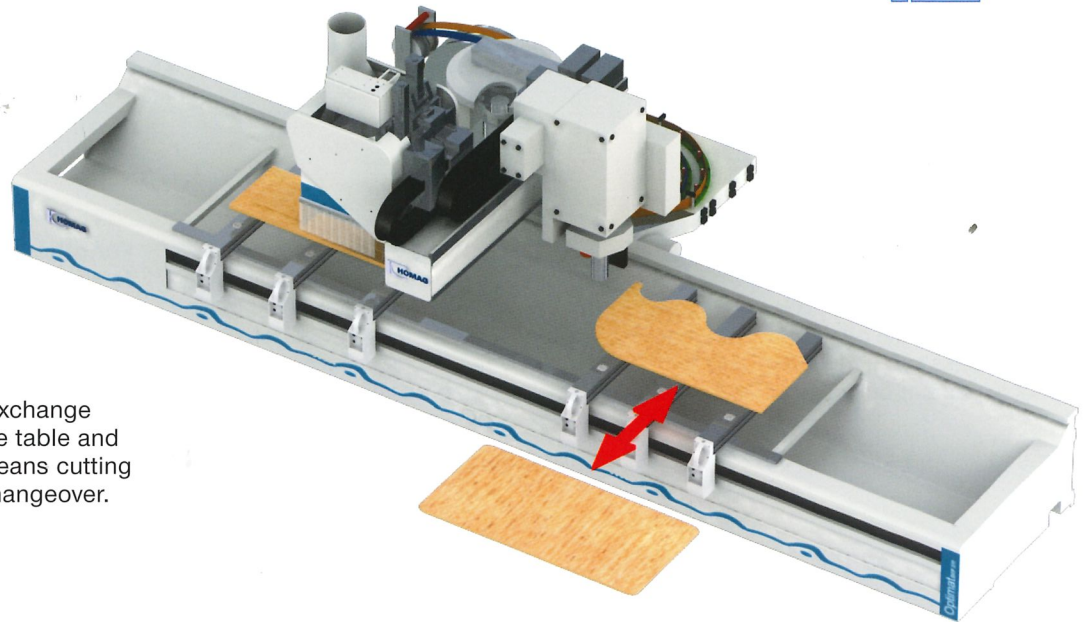

**Individual processing
in alternating operation**

Simultaneous workpiece exchange on one side of the machine table and production on the other means cutting out set-up times for tool changeover.

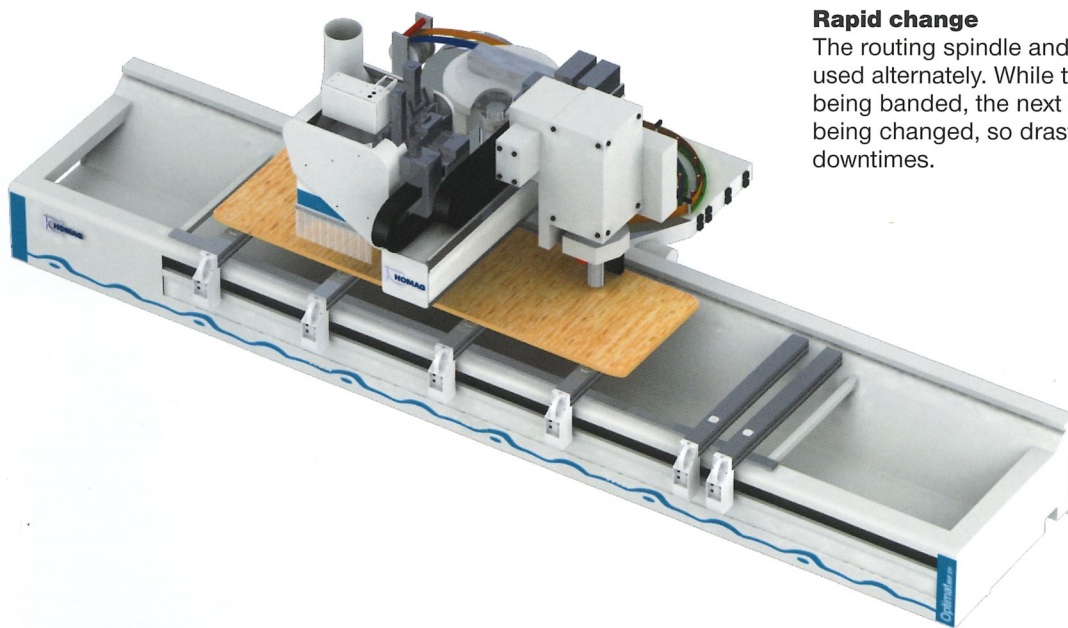

Rapid change

The routing spindle and gluing unit are used alternately. While the edge is being banded, the next tool is already being changed, so drastically reducing downtimes.

*Staircase step processing
with a traced unit*

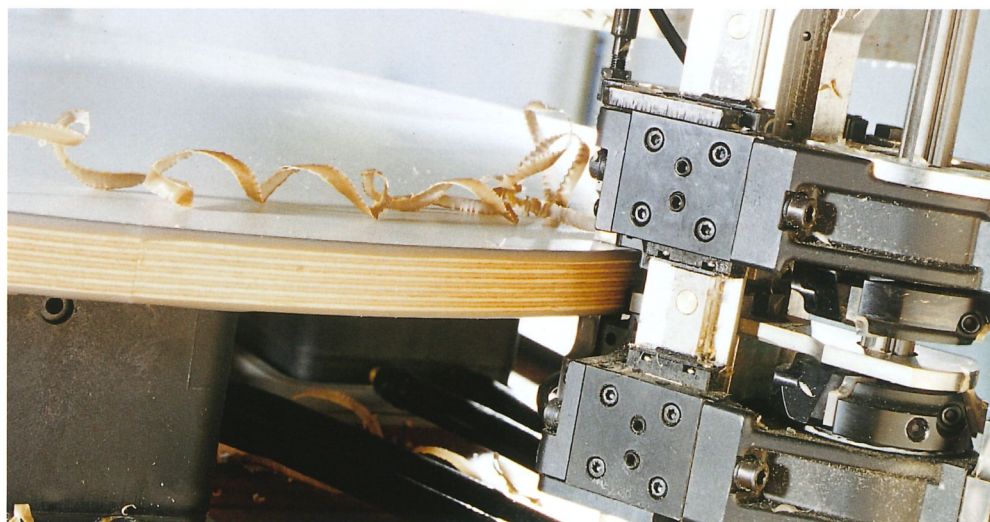

Table options to address your needs

Clean and fast: The K-table

This is the ideal answer for flexible manufacturing. Every column can be adjusted by a quick manual operation. The benefits: Hoseless vacuum system with a variable number of vacuum clamps

(pods). Both ends of the columns are fixed on precision guide-ways, permitting them to be moved without jamming. Precise fixturing of parts on the highly rigid columns allows for flexible, pin-point processing every time.

For other applications, please apply for our unit and clamping element catalog.

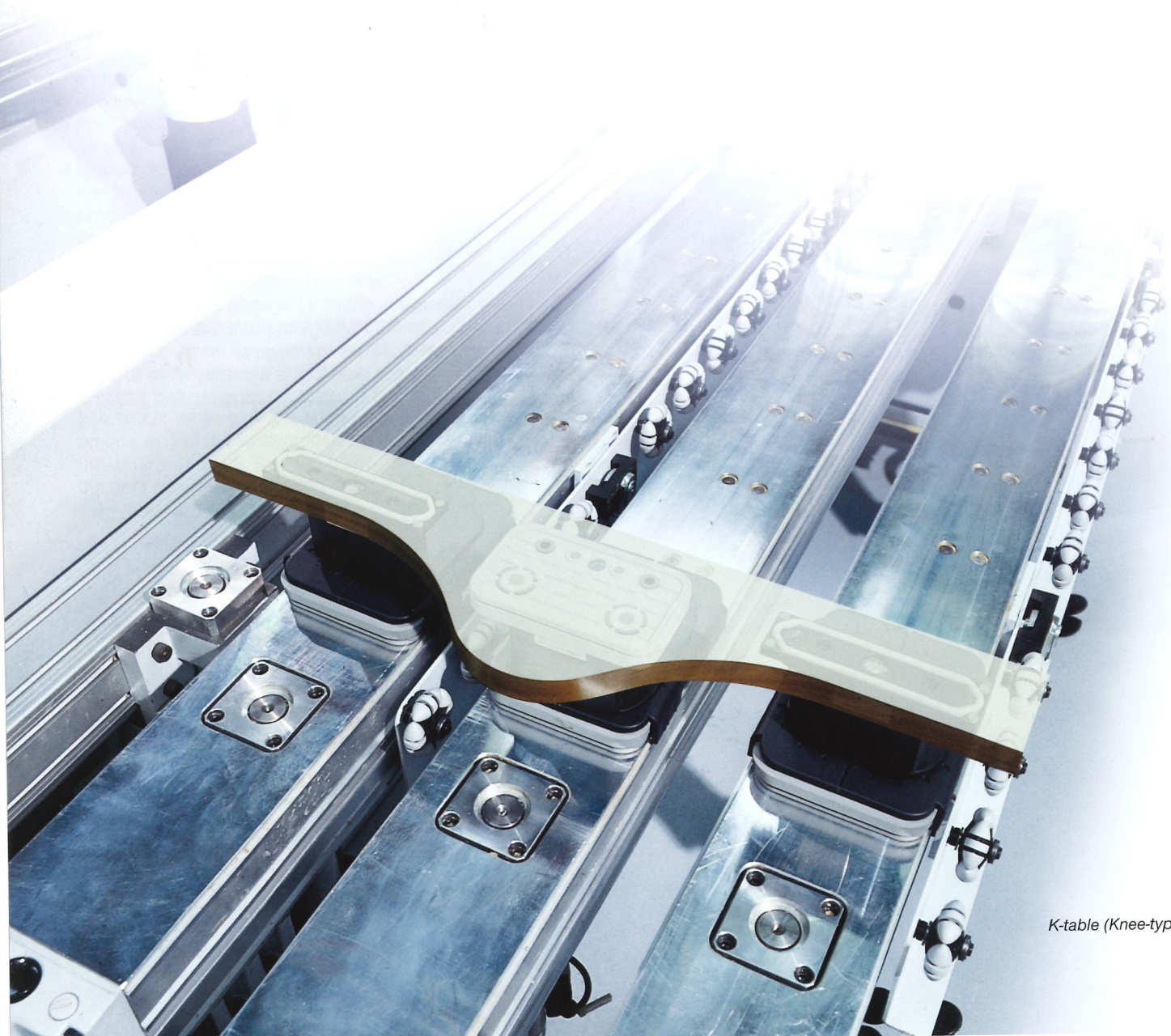

K-table (Knee-type)

Workpiece positioning

Large diameter locating pins provide the precise standard solution for fast, simple workpiece positioning. To adapt the clamping fixture to any products, we offer a wide range of clamping elements. These can be positioned using

a LED display integrated in one of the columns, or with the aid of a laser projection system. A ceiling-mounted laser system which also indicates the workpiece geometry is optionally available.

AutoClamp KC-table – less set-up, more performance

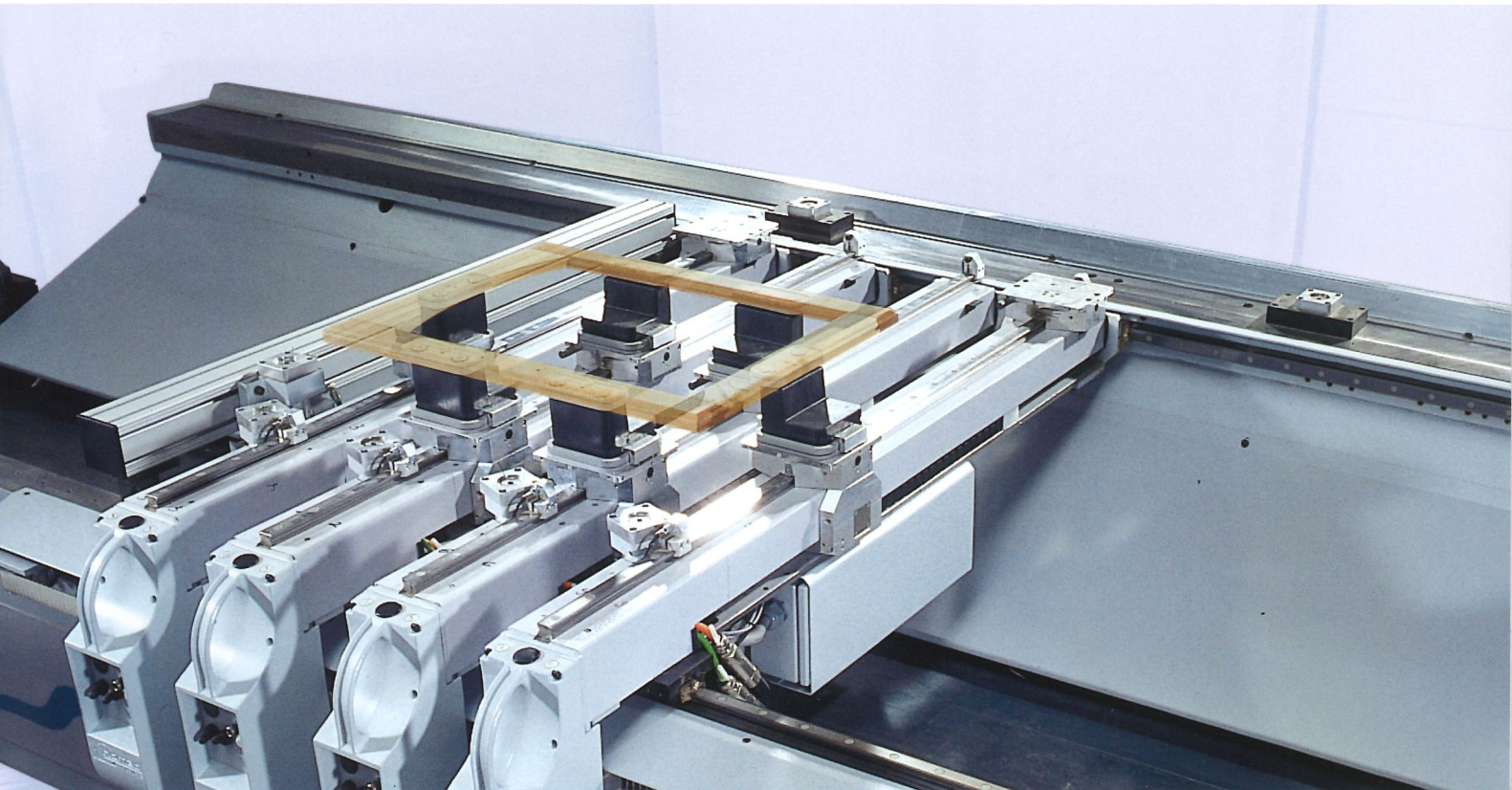

AutoClamp table

Fully automatic: The patented AutoClamp knee table

The newly developed AutoClamp knee-type table allows automatic table set-up including precisely positioned clamping elements.

The benefits: Resetting the work table during workpiece changeover reduces downtimes and ensures high output even for batch sizes as small as one. It also permits upgrading to create a production cell.

Different suction cup shapes can be used to accommodate varying work-piece geometry.

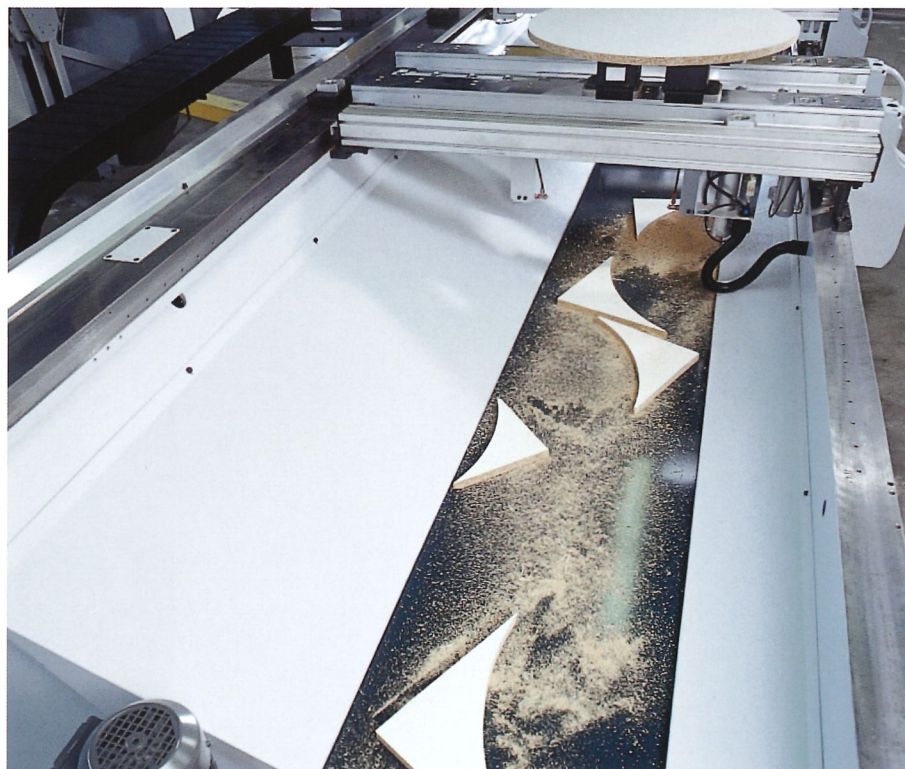

*Conveyor belt for automatic
waste disposal (optionally)*

G table – the standard option

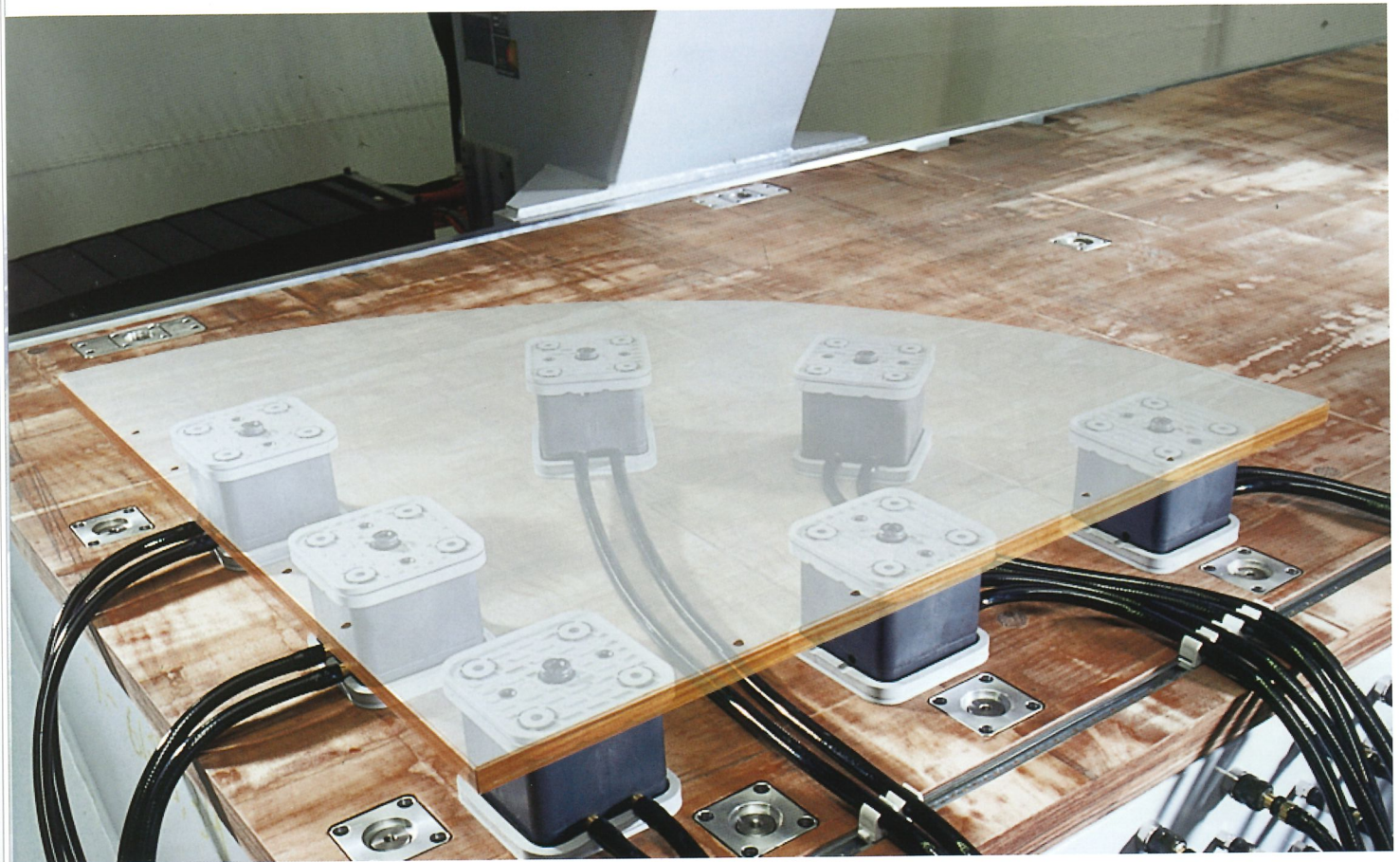

Closed, smooth table

The table is made up of a highly rigid multiplex panel which permits flexible positioning of the vacuum suction cups. A highly flexible solution which is particularly beneficial when working with complex geometries.

A firm hold on your workpieces

The workpiece is simply positioned using lateral and longitudinal reference pins. Freely positionable vacuum suction cups keep a secure grip on the workpiece while it is being processed.

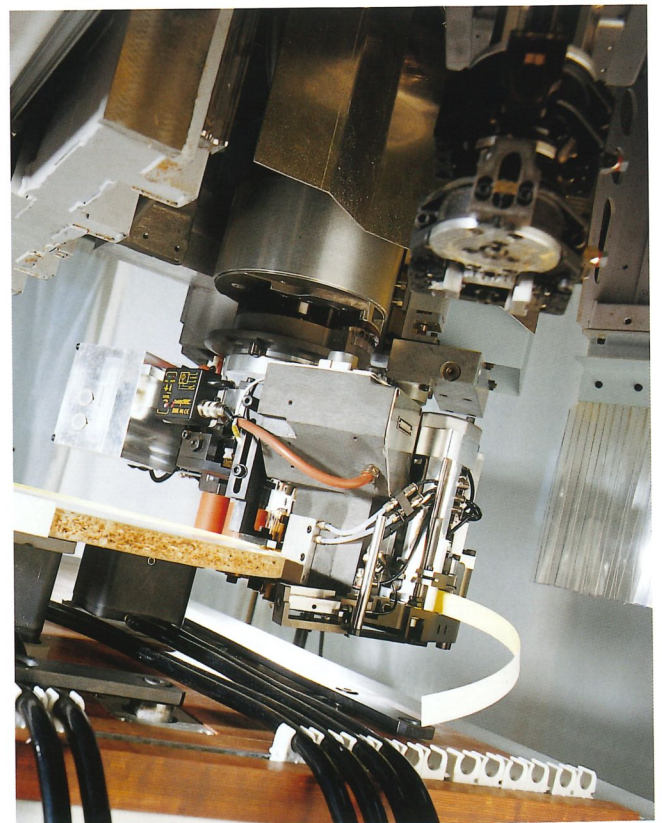

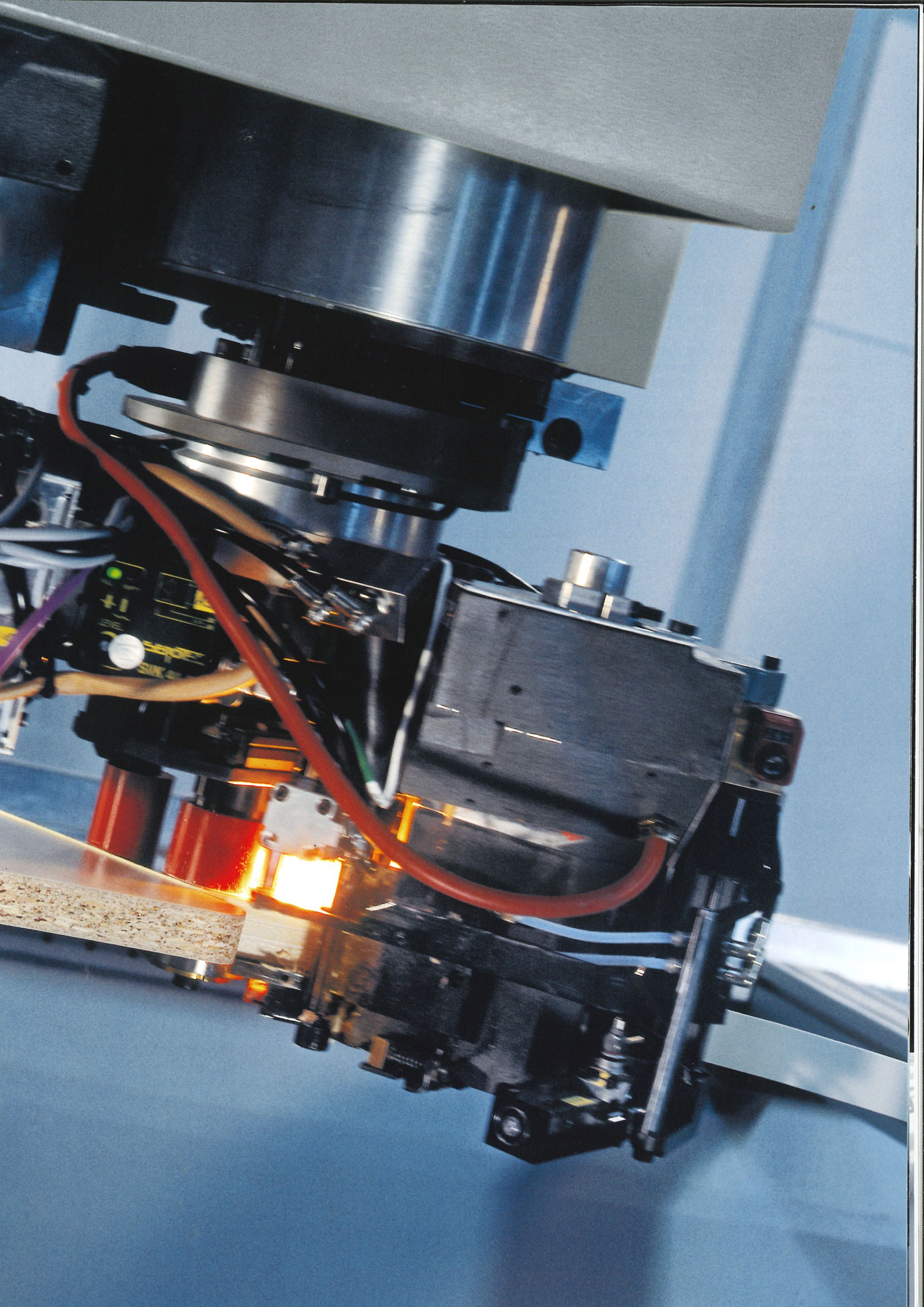

Spindle control for perfect results

Highlight on "Vector Spindle technology"

The use of a controlled spindle featuring with electronic speed monitoring offers a whole range of benefits:

- Electronically monitored power input protects the spindle from damage due to inconsistent materials (such as knots in the wood)
- HSC technology for higher cutting feed rates and optimum surface quality due to revolution speeds of up to 30,000 rpm
- No loss of speed under load, guaranteeing a consistent cutting rate and surface quality
- Full torque even at low speeds (e.g. when sanding)
- Liquid cooling of the spindle for constant operating temperatures and a longer service life

The patented Homag interface for every application

- Highly precise standardized tooling interface HSK-63F
- Four-dimensional interface for
 - Power transmission
 - Optional C-axis (the units inserted in the main spindle's long-life ceramic bearings can be optionally rotated by program and swivelled for cuts and drilling processes at any angle)
 - Pneumatic transmission (e.g. compressed air to blow away chips or to control tracing units)
 - Transmission of electronic control pulses (e.g. for operation of an exchange-mountable gluing unit)



Open interface

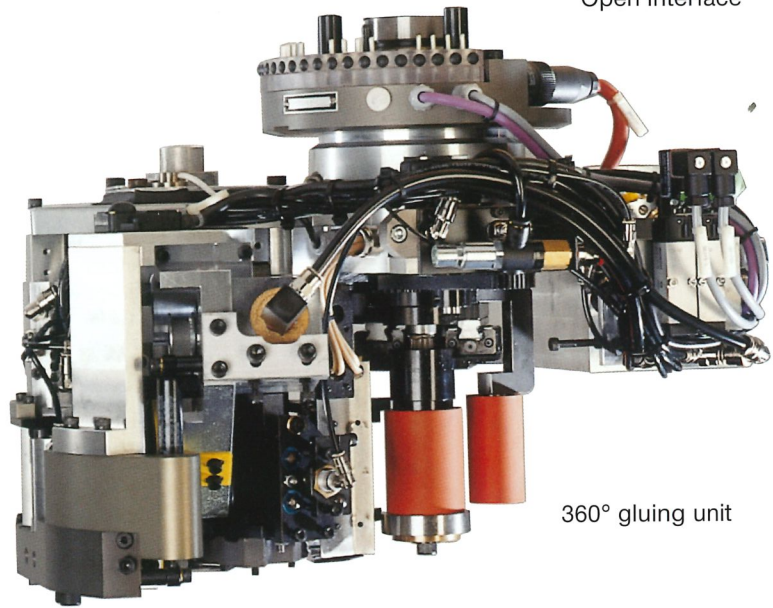

360° gluing unit

> **Routing spindles** with an output of 7.5 or 14.5 KW (10,0 or 19,5 HP)

The traced combination flush trimming and scraping unit makes use of the drive, C-axis and pneumatic interface.

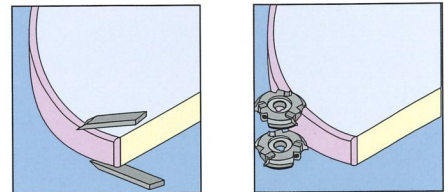

Performance on demand: The tool changer

The 12-fold plate changer is a cost-effective solution for 12 tools and units (optional 18-fold version available).

The patented interface allows you to add units as needed. For details of the wide range of units available for use with the interface, please refer to our separate unit and clamping element catalog.

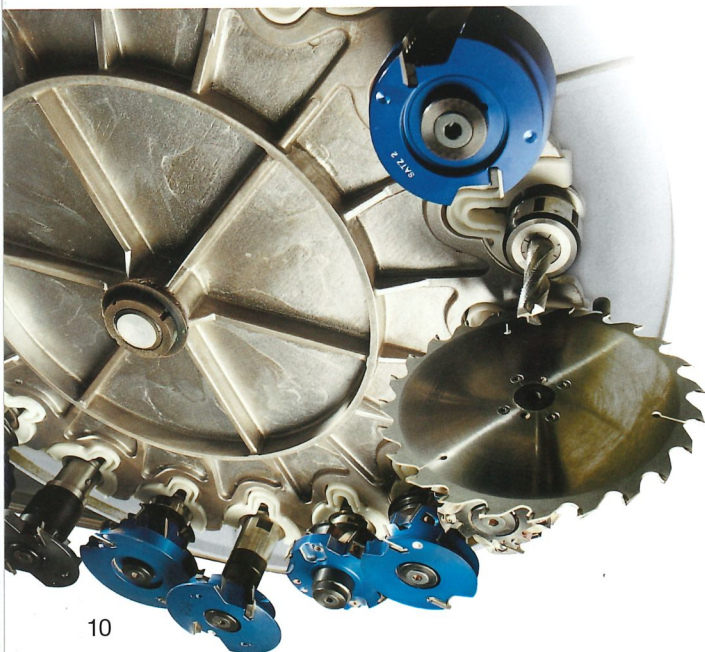

Perfected gluing technology

All-round perfect gluing technology

Homag gluing units permit economical edge banding, including finishing processes in a consistent standard of quality. Using just one exchangeable gluing unit, a machine with a working spindle can flexibly be turned into a router with added edge banding (including all-round 360° gluing). Using an independently operating separate gluing unit with incl. ride

along edge magazine, workpieces can be edged and trimmed. An edge pre-heating function allows even minimal corner radii of 8 mm to be edged with thick edging materials (depending on edge type). As a result, components such as office furniture work surfaces can be edged working using a single edge band without corner butt joints.

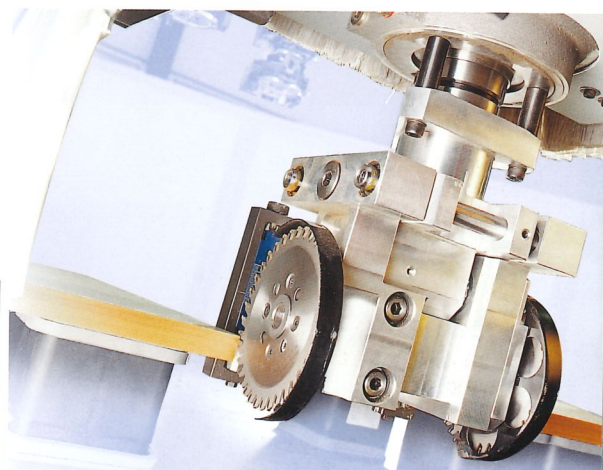
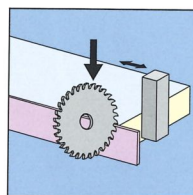
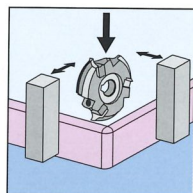
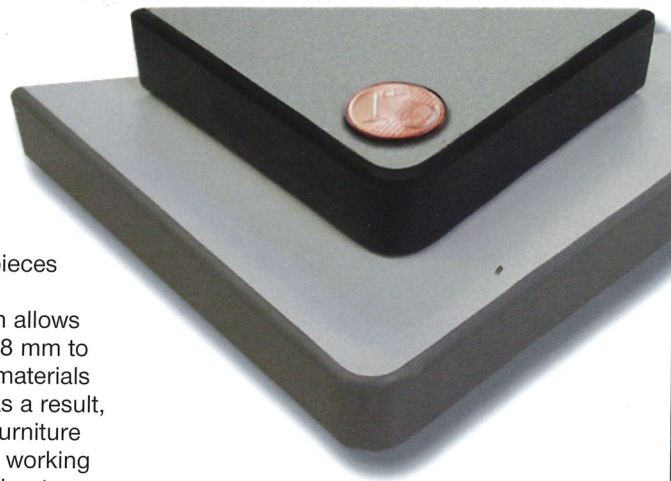

Only from Homag: Combined snipping and corner rounding unit with tracing

The traced unit takes care of ultra-precise snipping and corner rounding. The result: Finished articles in a unique standard of quality!



For the ultimate in production flexibility, ride along edging magazines to accommodate 1, 2 or 6 coils are available.

A drilling head with an extra dimension of flexibility

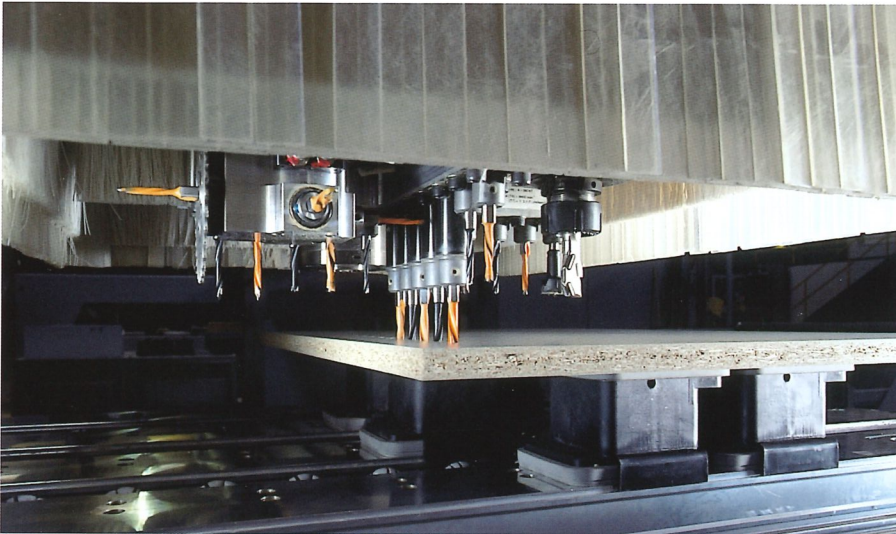

Upgradeable drilling head

The modular drilling head is optionally configured with either 12 or 17 vertical spindles. The standard double spindle bearings and cam-lock system provide the drilling head greater rigidity. In addition, one or two adapter units can be mounted. The benefit: this allows more tools to be used without changing the primary drilling unit or extend the number of vertical spindles up to 29.

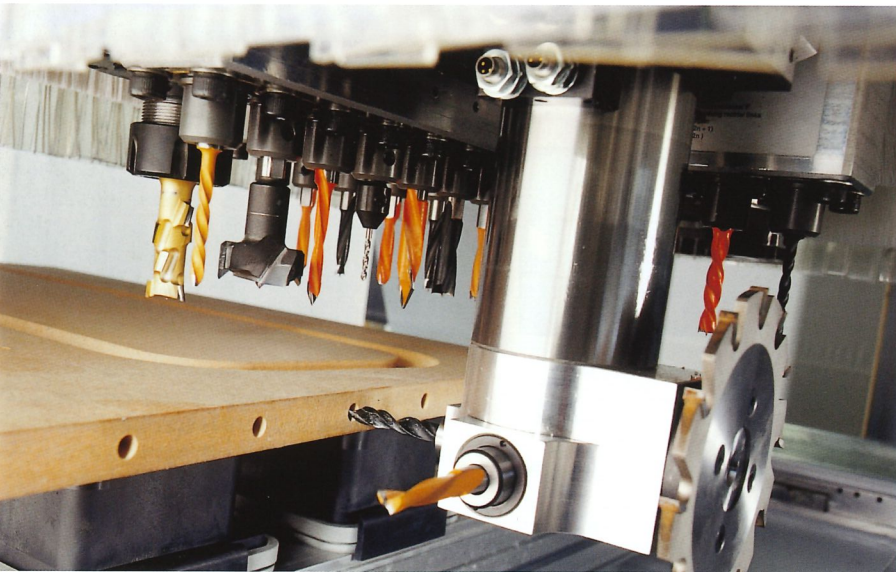

Adapter 4-spindle drilling head + saw

Three drills of different diameters for horizontal drilled hole and grooving saw blade can be optionally deployed in both the X and Y direction (optionally: 0-90 degree swivel facility).

For details of other available adapter units, please refer to our unit and clamping element catalog.



Adapter routing spindle

To reduce cycle times, an additional routing tool can be deployed directly without the need for an automatic tool changer.

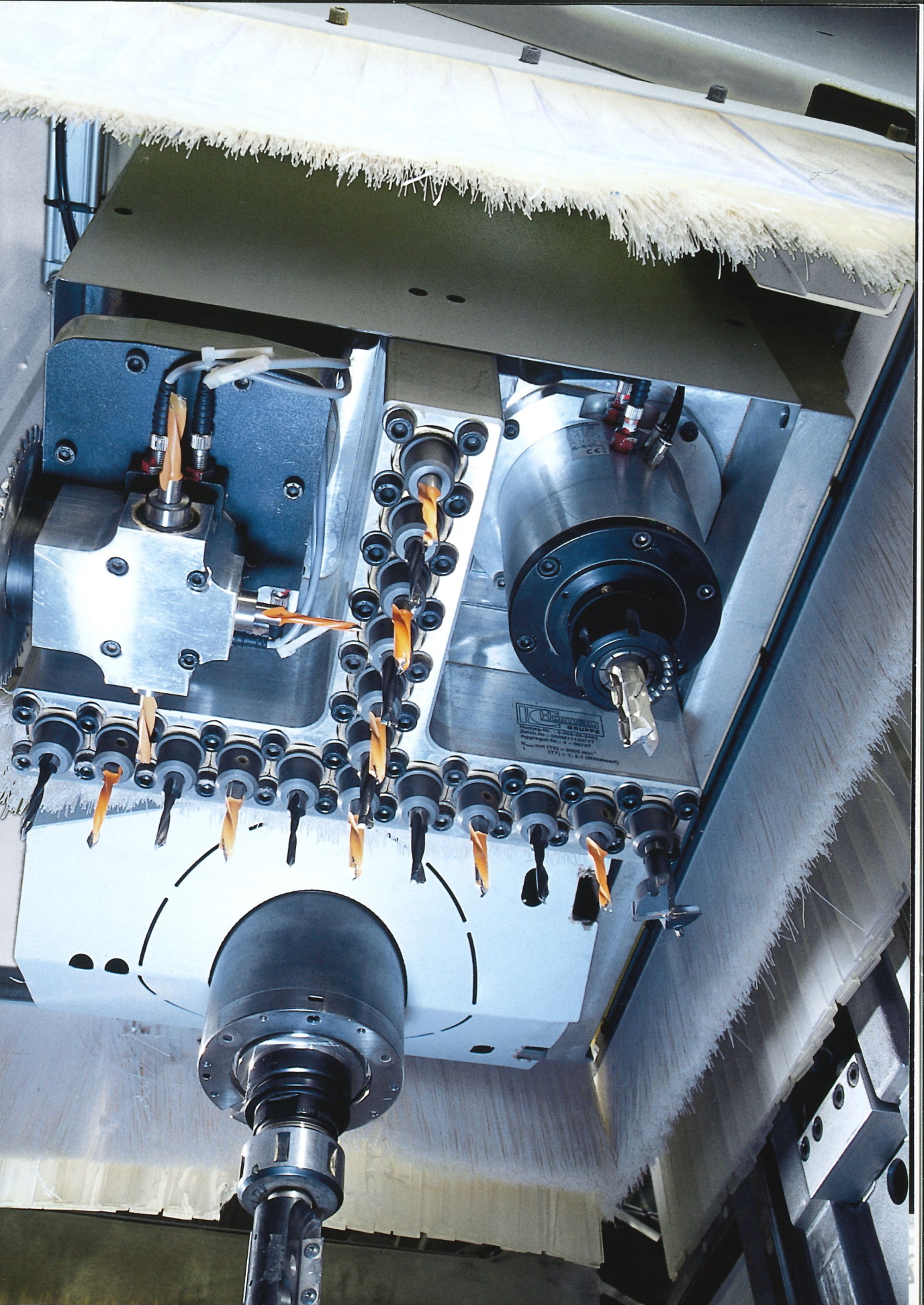

Simple control – automatic optimization

The Homag **power** control system PC85 is an open-ended and flexible control system for highly complex applications coupled with outstanding operating simplicity. The latest generation allows efficient combination of all machine-operating modes (alternating, rapid change and individual operation). Integration of different program steps (tool change optimization) occurs while processing takes place as a result of **Intelligent Process Optimization (IPO)**, meaning that ultra-efficient production is possible from as low as batch size one.

To allow the programs to be accessed in accordance with the workpiece sequence, an integrated job list control system is provided.

woodWOP – rationalization through fast programming

The wood working industries most popularly programming system in the woodworking industry offers outstanding support for optimum machine operation. Starting from the graphic tool database as an overview for existing tools, through the import of CAD drawings and data from trade-specific software packages (optional).

Machine data acquisition

Alongside a reliable machine, high performance is dependent upon environmental factors. To analyse and optimize organizational integration and material flow, the PC85 control system comes equipped with a basic machine data acquisition version as a standard feature. A professional version is optionally available which opens up scope for detailed evaluation and feedback to higher-level management systems.

Tool service life determination

In order to cut ancillary costs, a tool life management function is optionally available. This allows you to optimize your tool inventory and the associated upkeep costs.

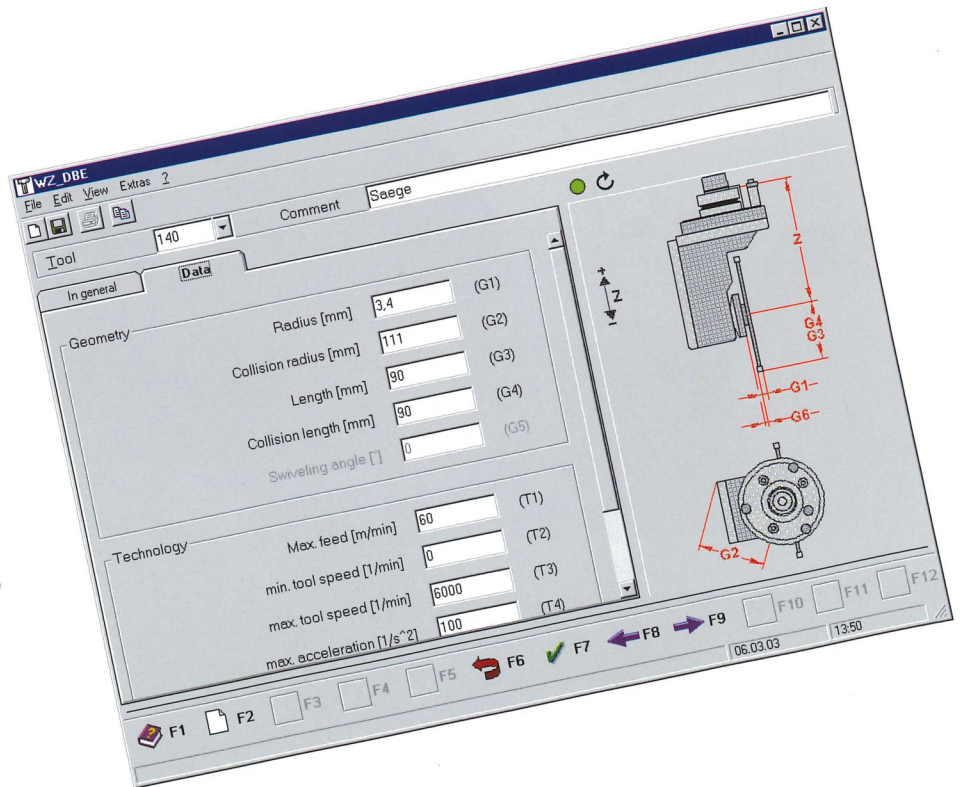
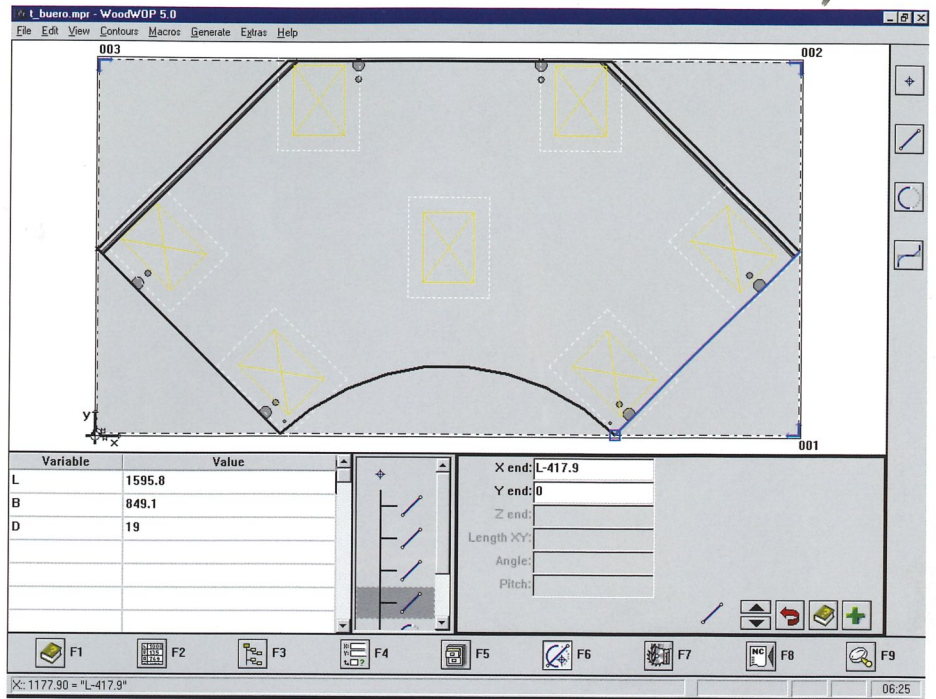

HOMAG

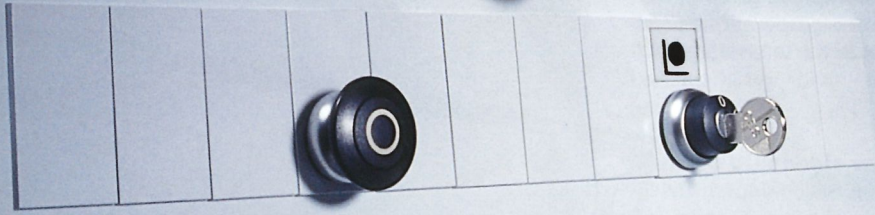
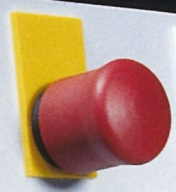
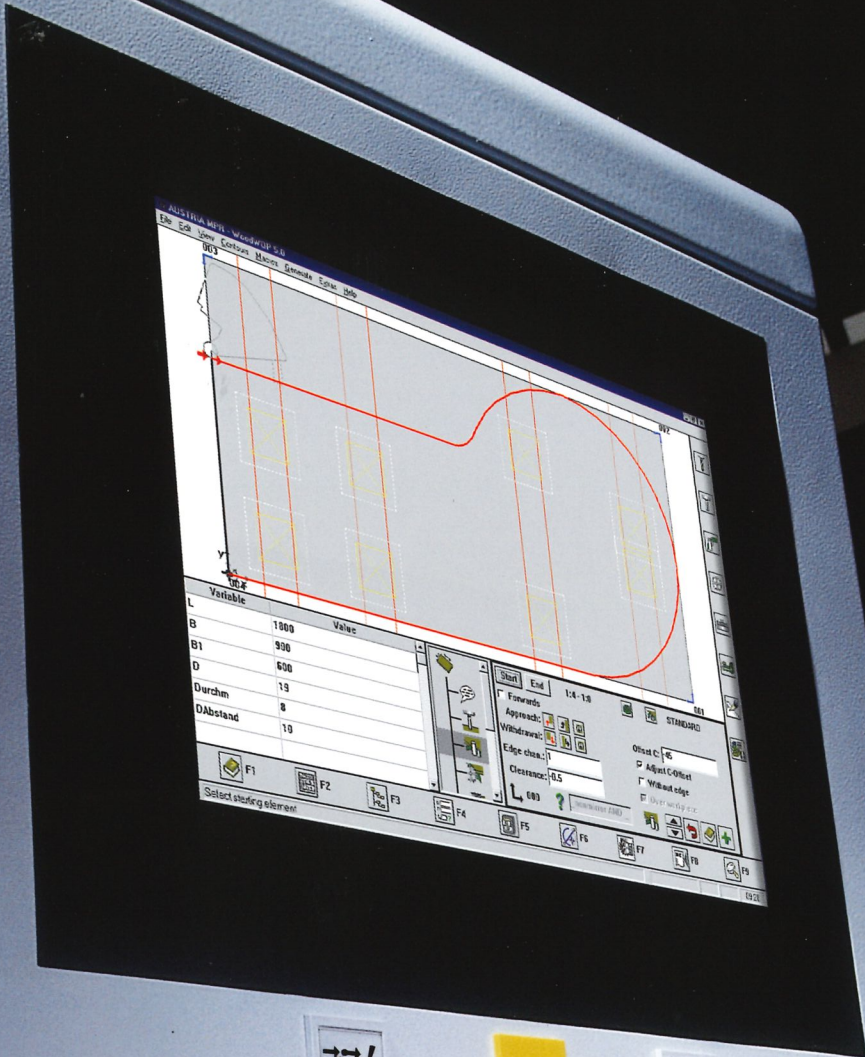

Software solutions from Homag

Integration made possible

Interfaces are optionally available which permit the integration or coupling to trade-specific software packages. This allows utilization of existing data from the production engineering department.

woodWOP-Wizard

The woodWOP is used to automatically generate the processing sequence for edging on the basis of the workpiece geometry, the edge transitions and a number of configurable rules of technology:

- Axially parallel edges (where appropriate already glued) are detected
- Roughing and pre-trimming
- Corner rounding
- Pre-swivel action for flush trimming
- Edges can be finished individually or together

woodDesign

The woodDesign allows the fast graphic entry of carcass furniture designs into the system.

woodScout – Help in a language you understand

In case of errors or faults, the unique diagnostic system (optionally) provides an in-valuable aid, graphically displaying the location of the fault at the machine and releasing an error message in easily understandable text.

woodWOP DXF interface

For the import of workpiece geometries and defined processing operations from CAD systems in the international DXF format.

All from a single source

Additional software products round off the wide performance spectrum of woodWOP. More detailed information is available on request.

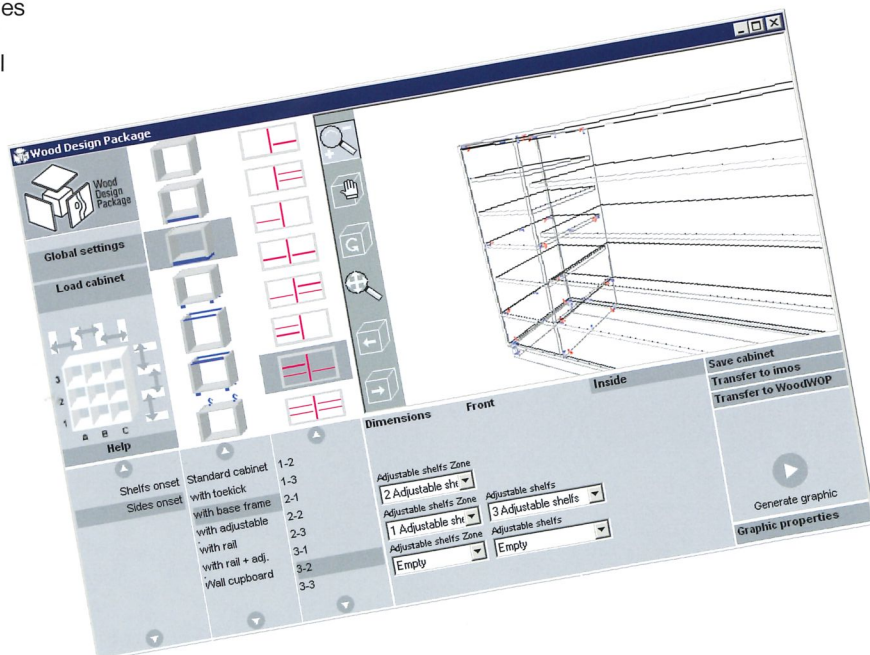
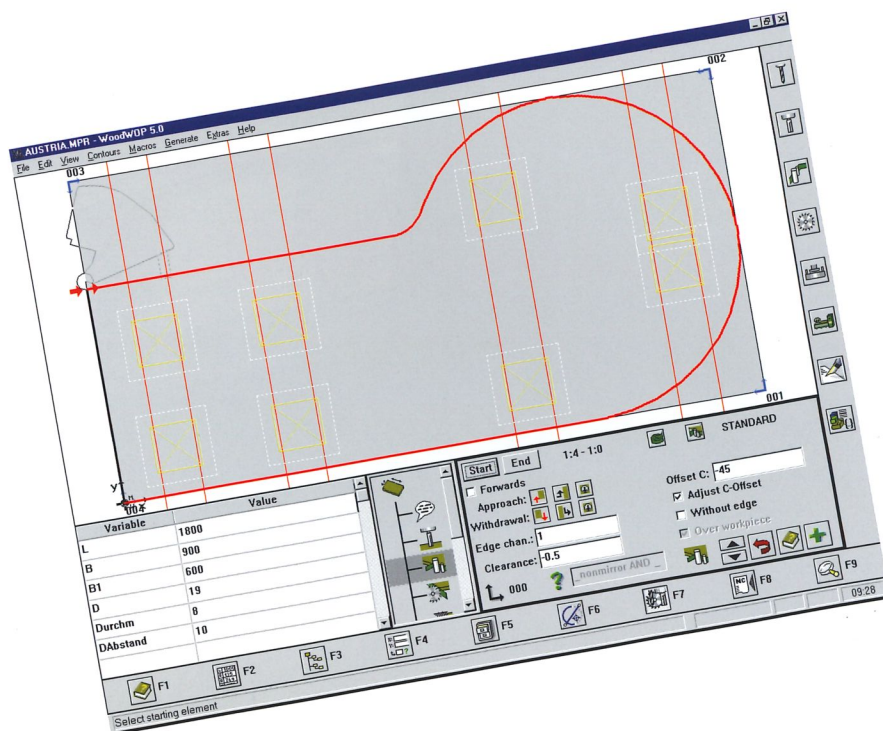

It pays to be a Homag customer



Homag is everywhere

A well-developed servicing, sales and dealer network means even greater proximity, rapid response and improved customer support – all over the world.

Practically-oriented training

Although Homag products are designed for outstanding operating simplicity, thorough training does help cut down on commissioning times, reduces scrap from trial and error, helps develop the skills of the operator and generally improves efficiency.

With this aim in mind, customer training courses are held in a number of languages in our own training centre.

Careful maintenance

Scheduled, correctly performed maintenance helps reducing costs and increasing the productivity and service life of plant and machinery.

Identical parts, simple handling

A large number of the parts, control elements and assemblies used in Homag Group plants and machines are identical. The wide-ranging benefits of this policy include simplified operation, lower costs, streamlining of spare parts management and also faster maintenance and servicing – to name only a few.

Remote diagnosis worldwide

All NC machines are fitted in the factory with a modem to allow remote diagnosis anywhere around the globe. A search for possible faults is performed from the Homag Service Centre. Once localized, they are narrowed and often already solved over the phone.

Solutions tailored to your needs

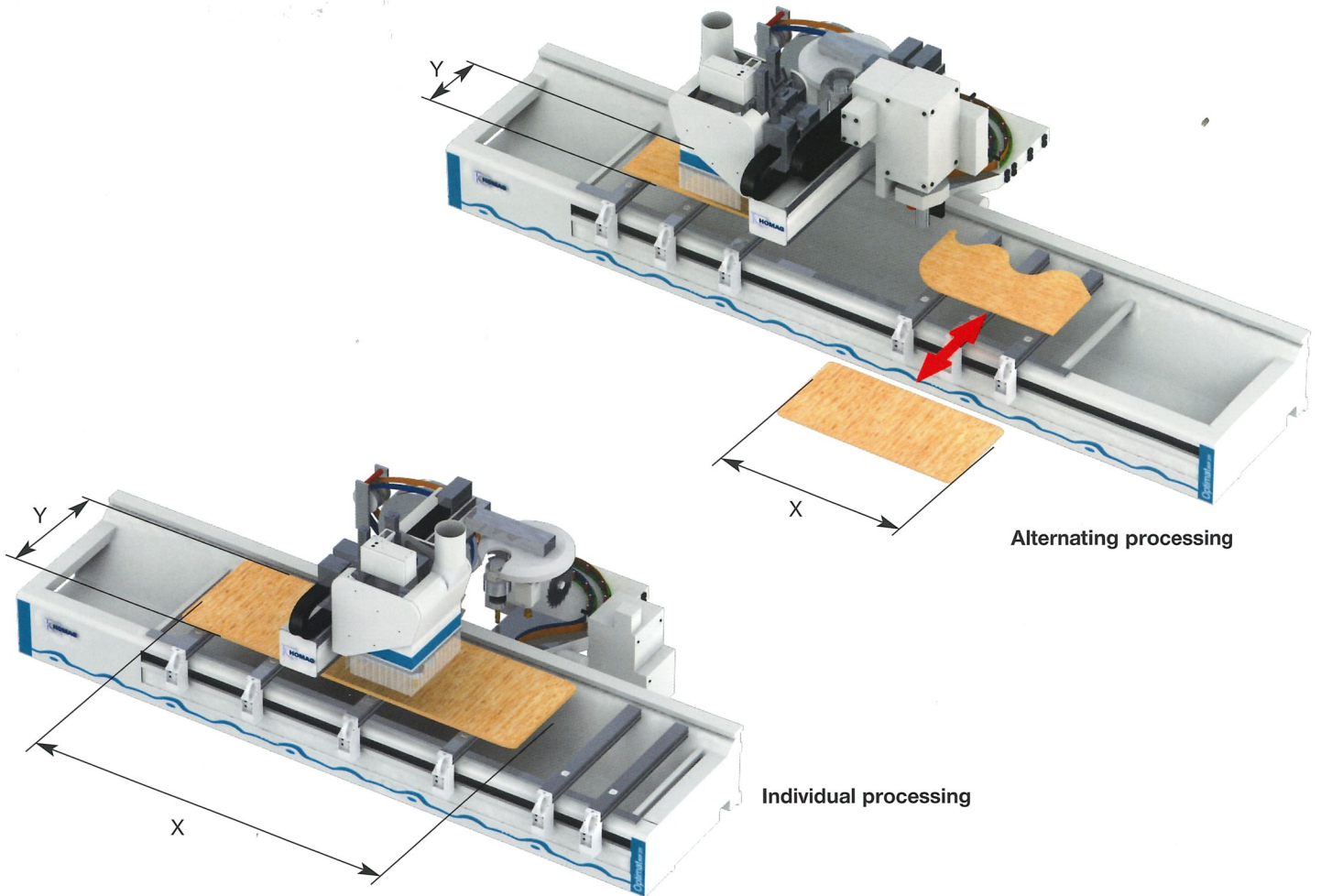

The new BAZ 300 processing centre series offers a wide product range with a choice of 6 different standard models. For larger processing dimensions, please enquire about our BAZ 700 processing centres.

	Optimat	
Processing dimensions (example knee table)	BAZ 311	BAZ 322
X = Max. processing widths including gluing		
Individual processing type 30 [mm]	3050 (120")	-
Individual processing type 40 [mm]	4000 (157")	4000 (157")
Individual processing type 52 [mm]	5200 (204")	-
Individual processing type 60 [mm]	6000 (236")	6000 (236")
Individual processing type 72 [mm]	7200 (283")	-
Alternating processing type 30 [mm]	900 (35")	-
Alternating processing type 40 [mm]	1375 (54")	1375 (54")
Alternating processing type 52 [mm]	1975 (77")	-
Alternating processing type 60 [mm]	2375 (94")	2375 (94")
Alternating processing type 72 [mm]	2975 (117")	-
Y = Max. processing depths		
Standard for routing operations with tool diameter 25 mm [mm]	1700 (67")	1700 (67")
Option with secondary spindle, knee extension and tool diameter 25 mm [mm]	2000 (78")	2000 (78")
Including gluing [mm]	1600 (63")	1600 (63")
Max. working heights		
Routing operations including clamping elements [mm]	300 (11,81")	300 (11,81")
Workpiece height during gluing [mm]	60 (2,36")	60 (2,36")

Compact performance

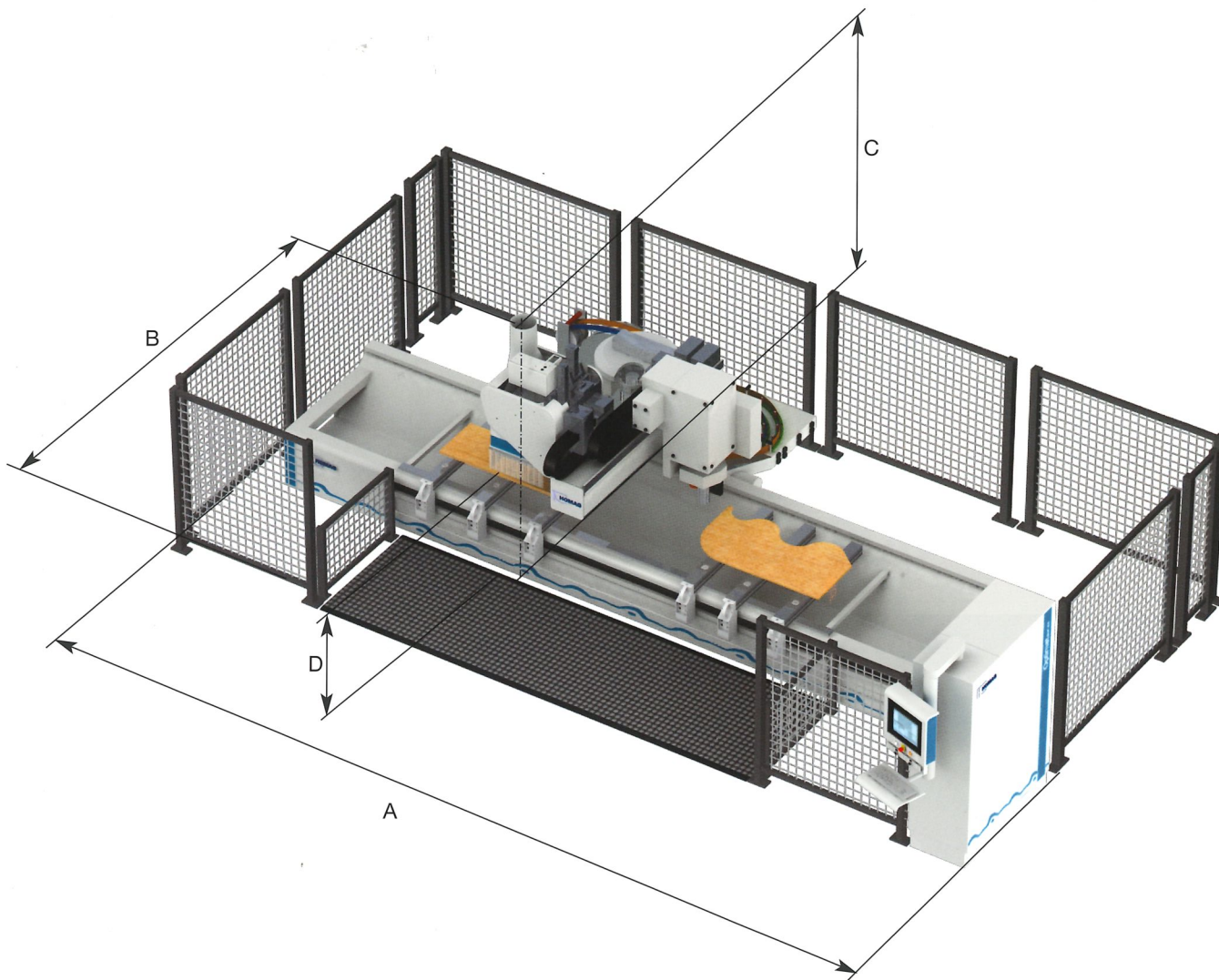

The compact extension arm design offers a large work area coupled with low space requirement.

Set-up dimensions	Optimat	
	BAZ 311	BAZ 322
A = Length for type 30 [mm]	7500 (296")	-
A = Length for type 40 [mm]	8500 (335")	10000 (394")
A = Length for type 52 [mm]	9750 (384")	-
A = Length for type 60 [mm]	10500 (414")	12000 (473")
A = Length for type 72 [mm]	11750 (463")	-
B = Width [mm]	5500 (217")	5500 (217")
C = Height [mm]	2900 (114")	2900 (114")
D = Working height [mm]	950 (37,40")	950 (37,40")
Extraction output [m3/h]	5000 (2940 C.F.M.)	5000 (2940 C.F.M.)
Extraction port diameter [mm]	250 (9,84")	250 (9,84")
Compressed air consumption [NL/min]	400 (14 C.F.M.)	400 400 (14 C.F.M.)
Electrical connected load [KW]	from 20 (27 HP)	from 25 (34 HP)

Specification and photo details without commitment. We reserve the express right to make changes in the interests of progress.

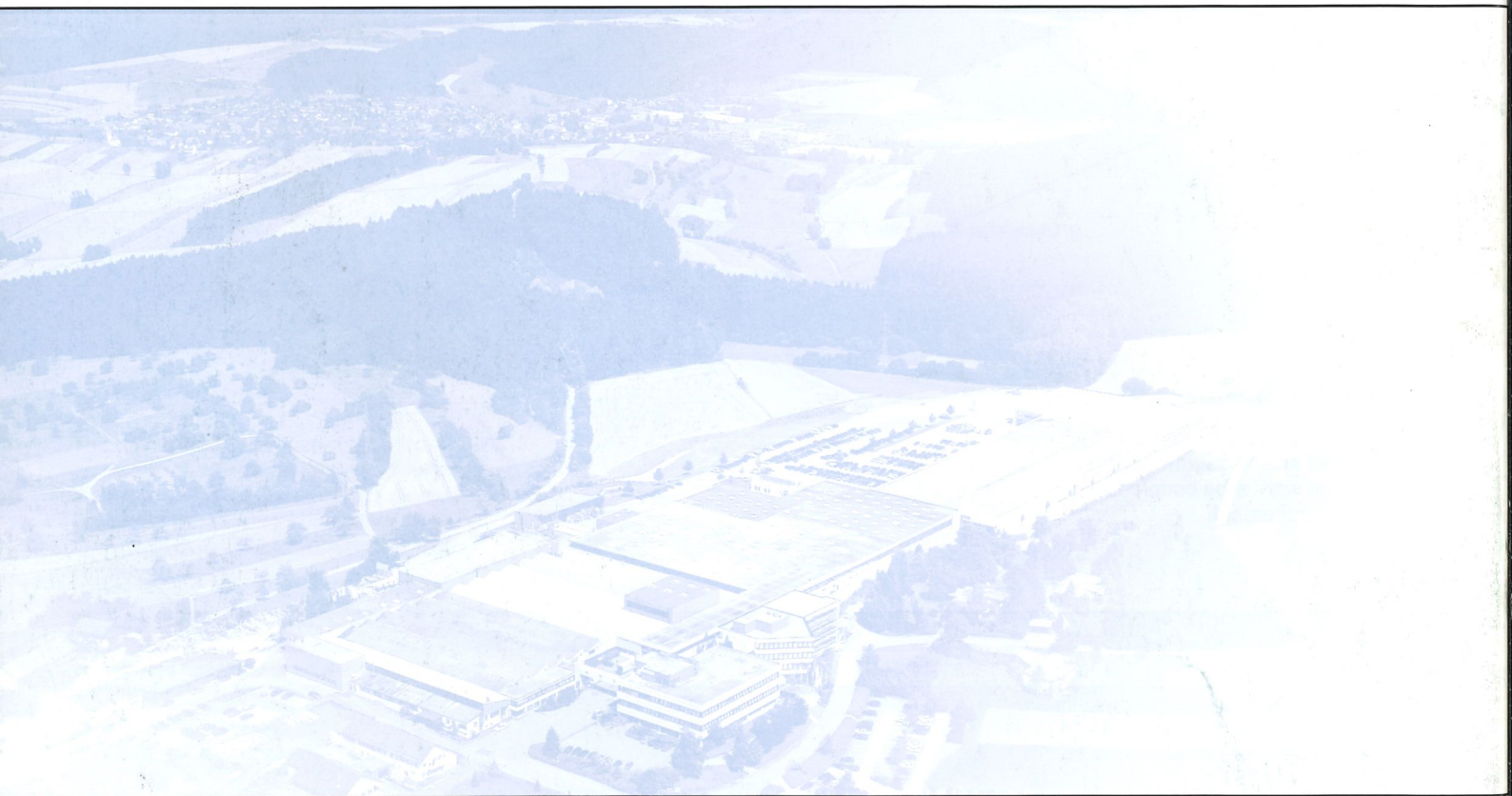

A member of the Homag Group



Homag Holzbearbeitungssysteme AG

Homagstraße 3-5
72296 SCHOPFLOCH
GERMANY

Tel.: +49 (74 43) 13-0
Fax: +49 (74 43) 13 23 00
E-Mail: info@homag.de
Internet: www.homag.com

