

# **BIESSE STREAM B**

Automatic single-sided edgebanding machines

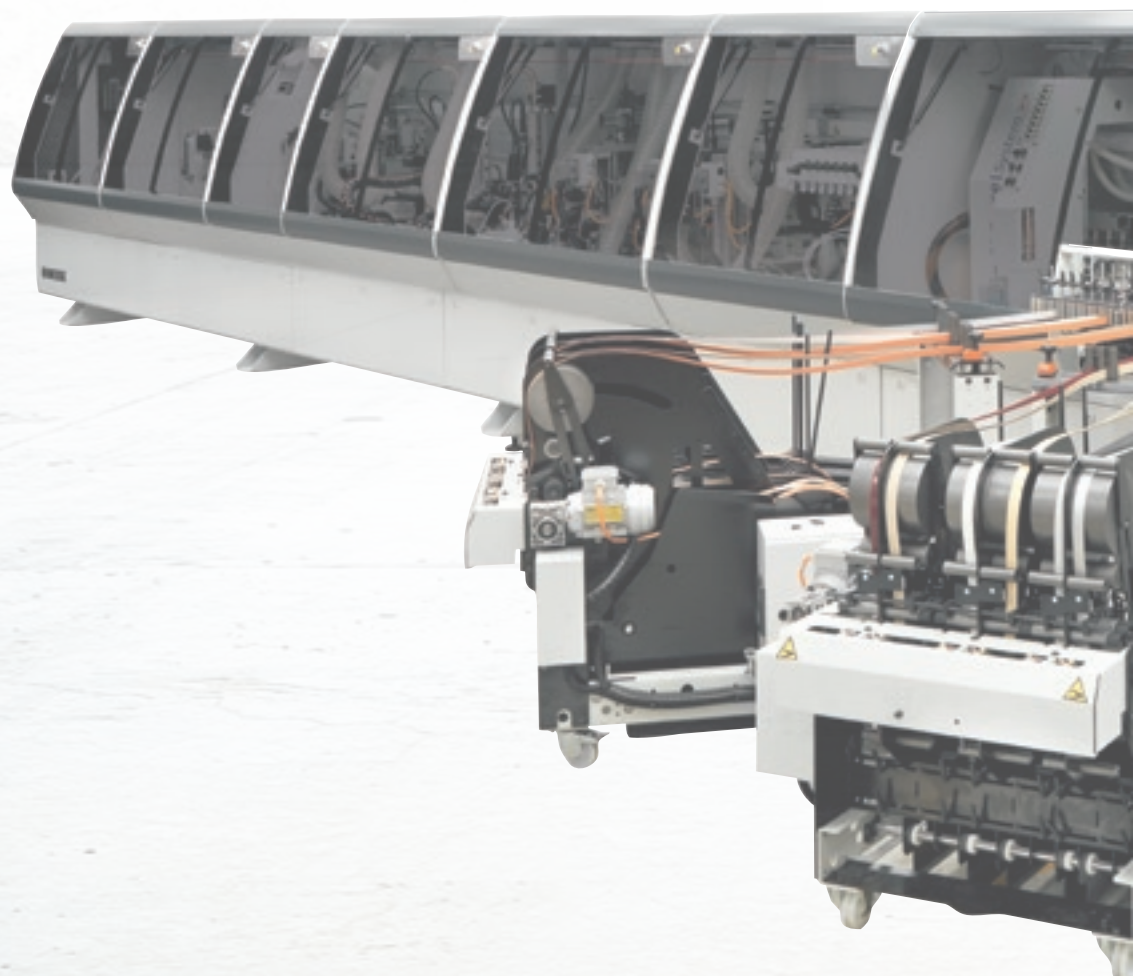

When competitiveness  
means high productivity



Made **In** Biesse

## The market demands

a change in manufacturing processes that will enable companies to **accept the largest possible number of orders**. This is coupled with the need to maintain high quality standards whilst offering **product customisation** with quick and defined delivery times, as well as responding to the needs of the most highly automated enterprises.

## Biesse responds

with technological solutions that guarantee high quality lasting performance for long periods of time. Stream B is a single sided edgebander that meets the needs of large companies for high productivity. It can cover three work shifts, 7 days a week, and has an endless number of possibilities for product customisation based on production requirements.

- 
- A large industrial machine, likely an edgebander, is shown in a factory setting. It has a complex structure with various rollers, belts, and a control panel. The machine is white and grey, and is positioned on a light-colored floor. The background shows other industrial equipment and a clean, well-lit environment.
- ✓ **Reliable technology.**
  - ✓ **Perfect integration in company work-flows.**
  - ✓ **Optimal edge grip.**
  - ✓ **Machining precision.**
  - ✓ **Attention to detail.**

# Perfect edgebanding



 **BIESSE STREAM B**

Automatic single-sided edgebanding machines



# Can be configured for all types of machining

**Stream B can be configured to suit customers with an endless number of possibilities.**



Pre-milling unit.

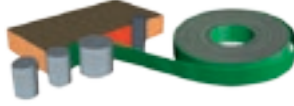

Gluing unit.

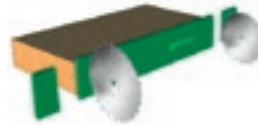

End trimmer.

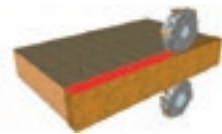

Rough trimmer.



Fine trimmer.



Corner rounding unit.

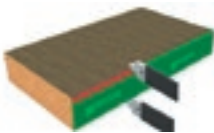

Edge scraper.

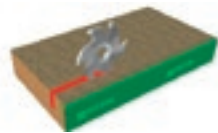

Grooving unit.

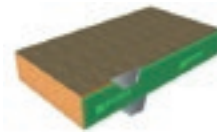

Glue scraper.

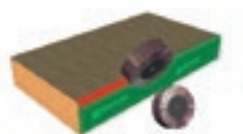

Buffing unit.



Sanding unit.

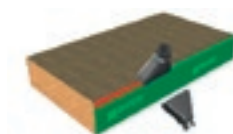

Hot air blower.

Maximum precision  
on special shapes too.



All the units available on this machine have servo-assisted movement which guarantees excellent performance when reliability, speed and positioning precision are required.



Biesse fits **ROTAX electrospindles** as standard on all its machines which are **built exclusively for Biesse by HSD**, a leading international company in the sector, and guarantee power, a compact size and extremely high finishing standards.

# Reliable technology

The structure of the machine is extremely robust and rigid, sized with cutting edge calculation and design tools.



The **Monolithic Base** provides high stability and allows the machine to operate 24 hours a day, 7 days a week whilst continuing to deliver high quality standards.



The **Belt Presser**, which is standard in the Stream B, allows the panel to run on the belt guaranteeing uniform pressure which is ideal even for more delicate coverings.



Stream B can also be used to customise the machine's structure and guarantee maximum productivity with a series of options that increase the machine's performance.



The **First Run Wheels** perfectly align the panel on the lengthwise run through constant pressure of the 3 rubber wheels.

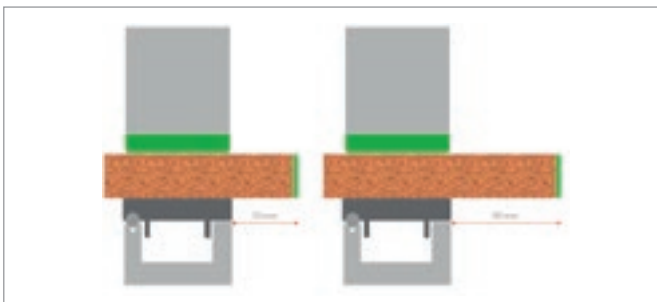

Industrial conveyor chain.



The **Movable Tables** can be used for machining which is not possible on other machines with fixed machining lines. One of the most widely used applications is the creation of channels that are more than 35 mm deep.



The **Square infeed system** is a device that guarantees that long, narrow panels are perfectly inserted into the machine for transversal machining.



# Perfect integration into production flows

Biesse can provide bespoke solutions which are tailored to meet your specific productivity, automation and space requirements.



The **Foster infeed device** is an **automatic feeder** that allows panels of any size to be correctly inserted into the machine on the crosswise run.



The **Parallelogram Piece Support** is an extended side support that can be used to machine large panels.

# Design of integrated lines over 100 metres long



**BiesseSystems** provides a full project consultancy and management service to companies who wish to implement integrated technology solutions for their manufacturing processes.

In addition, a team of sector experts, who can understand and anticipate company needs, are always on hand to work with the customer from inception through to system installation and commissioning.

Over 300 systems  
sold worldwide.

# Eco-friendly edgebanding



Stream B has a green energy saving package which optimises suction and electricity consumption.

# Perfect gluing surface

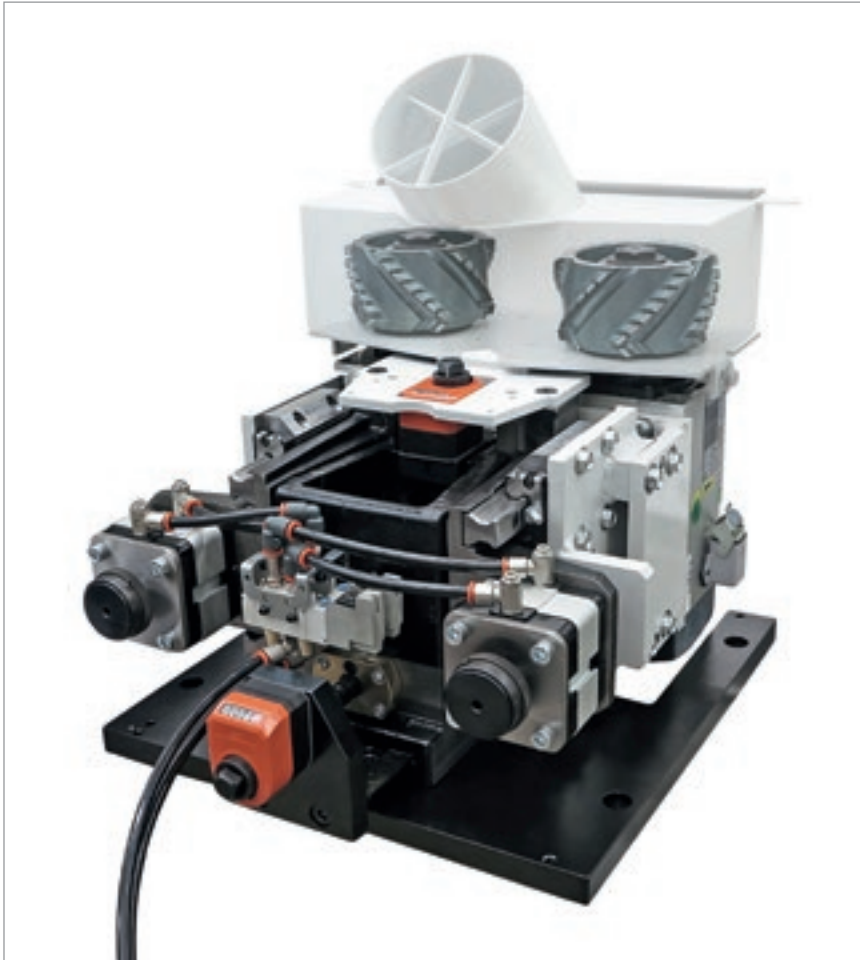

The **RT20 2-motor Pre-milling Unit** with automatic intervention guarantees a perfect base for gluing. New optimisation of the suction system guarantees optimum cleaning.



The **RT30 2-motor Pre-milling Unit** with automatic intervention guarantees a perfect base for gluing. With its dual copying system, it can machine the panel profile without losing the squaring.

# Optimal edge adhesion

Technological solutions created to guarantee high quality standards.

Gluing Unit for the automatic application of edging in rolls or strips, from 0.4 to 20 mm. It comes as standard with dedicated movement on glue roller, strip loading roller and pressure roller.

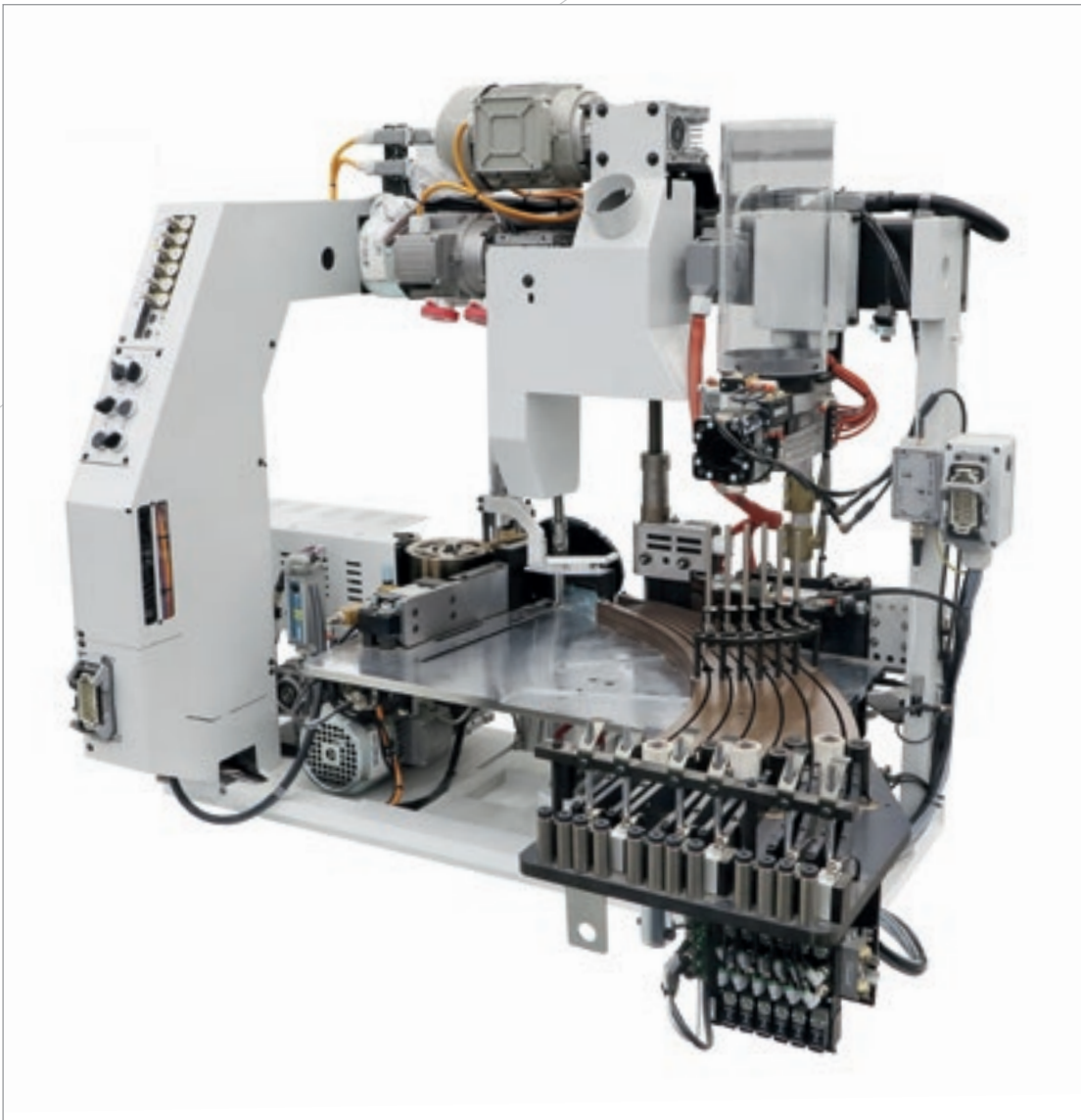

## SP10

Used to apply edging in rolls from 0.4 to 3 mm and covers most machining requirements.

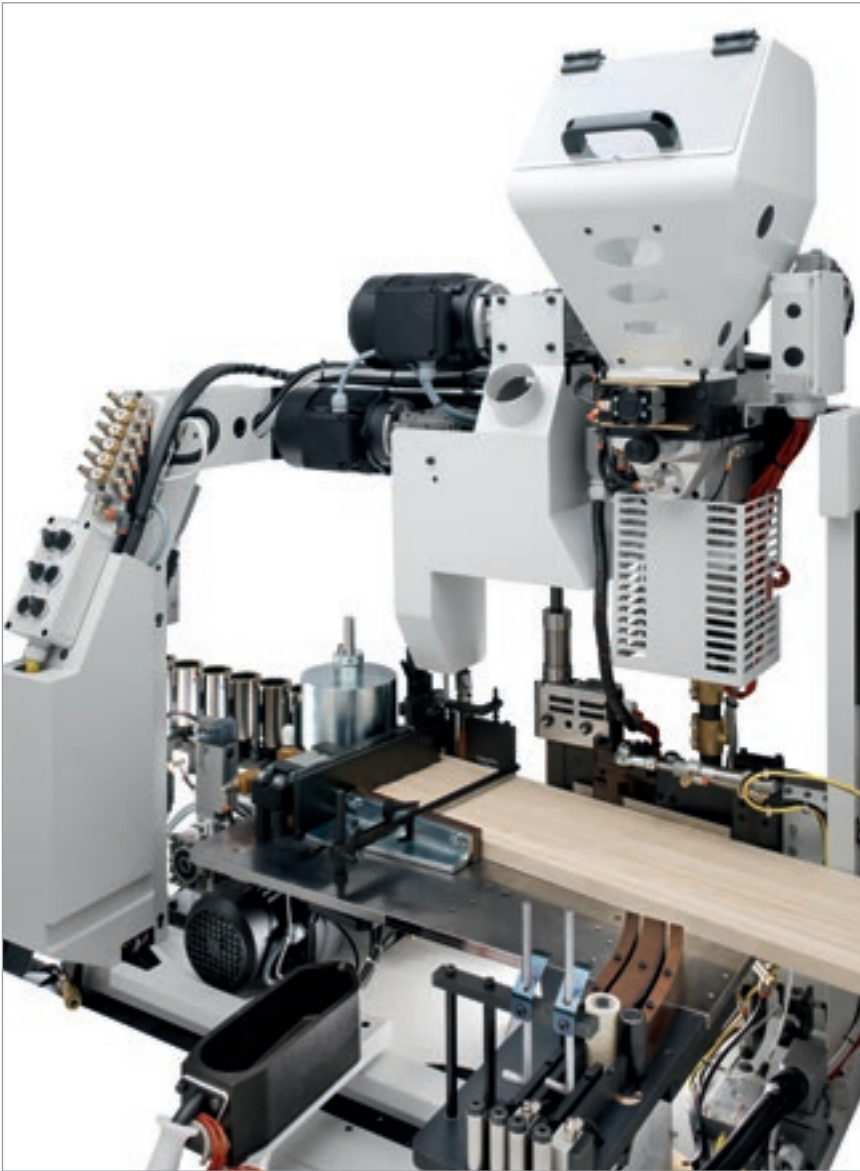

### SP20

Unit specifically for machining up to 20 mm thick solid wood edging in rolls or strips.



### SP30

The ideal solution for machining that requires high speed and rapid setup times.

# Multiple solutions for optimum management of glue

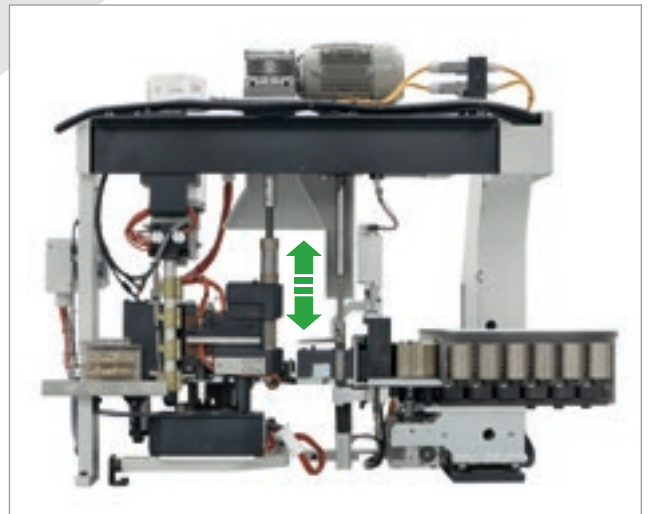
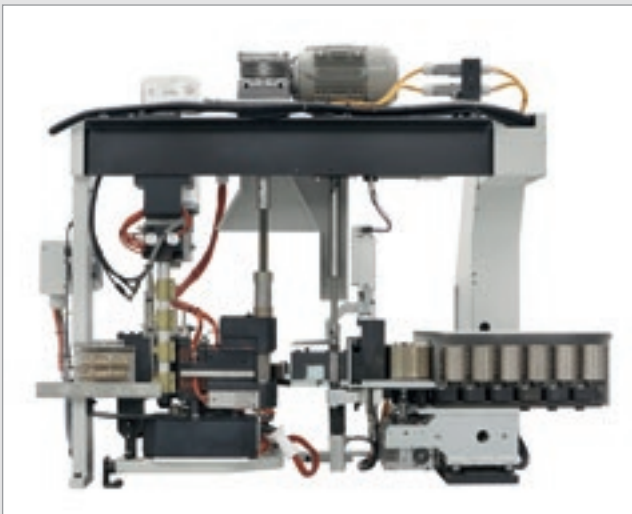

**High Melt** is a Biesse-patented continuous glue recycling system that keeps the machine clean without burning the glue.



Magazine for multiple edge management. Thanks to a magazine that can house a wide combination of edges, the unit guarantees unprecedented flexibility.



The **HM20 Premelter** is a pot for glue in granular form that with its large capacity guarantees constant machining for long periods in full autonomy.





Biesse offers specific solutions for the use of polyurethane glues resistant to heat, humidity and water.



**gPod, the Biesse device for polyurethane glue** with "PUR on demand" system for melting only the required amount of glue in real time..



**Nordson pre-melter for high production needs.** An exclusive direct injection system for non-stop machining operations at high speed and consumption levels.



# Invisible Edgebanding

A close-up photograph of a wood edge being processed by a machine. The wood is light-colored, and the edgebanding material is a darker, textured material. The machine is applying a clear, adhesive-like substance to the edge, creating a seamless bond. The background is dark and out of focus.

Air Force System, available on Biesse edgebanding machines, is based on the physical principle of convection. By using a compressed hot air system, the edge bonds perfectly with the panel, guaranteeing resistance to water and heat and an excellent long-lasting quality finish.

## **AIR FORCE SYSTEM**

No joints and no glue line, in perfect harmony with the panel. A perfect combination of Biesse quality and Italian genius.



# Machining operation precision

**A specific Research & Development team creates pioneering solutions to meet the market requirements and offer cutting edge technology that's reliable and guarantees first class results.**

Cutting quality and precision thanks to the End Trimmer that supports the trimming of the panel edge at both ends. Various solutions available depending on machining requirements.



IT90S, pneumatic end trimmer with linear movement.



IT90X, linear end trimmer with brushless movement for high machining speed.

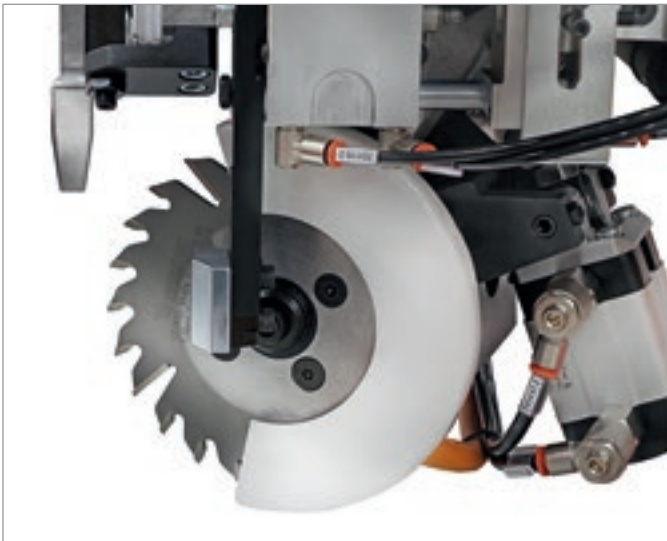

The **copying and tracing system** also guarantees optimal finishing quality on high-gloss edges with film. The 3 pneumatic positions of the front tracer can be used to control the finishing of 3 different edge thicknesses.

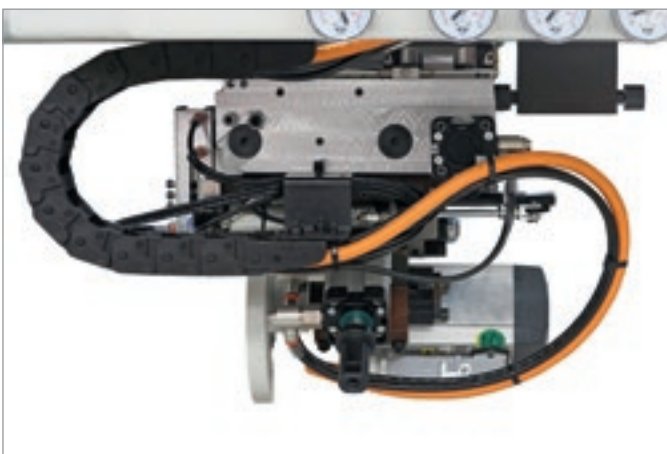

The movement of the machine on its axis, on linear guides, allows very high machining speeds to be reached.

# Reduced production time

**Stream B offers personalised solutions that reduce set-up and machining times.**

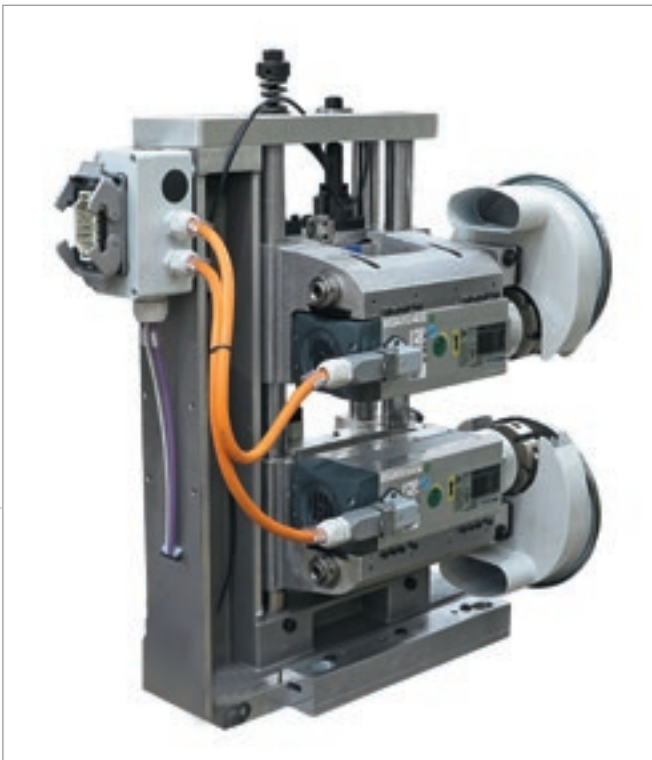

The **Overlapping Rough Trimmer** reduces the excess edge on the top and bottom of the panel. It also guarantees a perfect finish for solid wood, in one single movement.

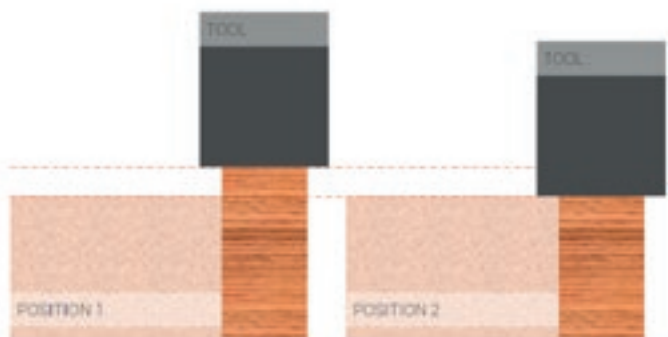

**Duo System** is a device for the automatic changeover between the rough-shaping and finishing functions.

The Fine Trimming Unit trims the top and bottom of the edges with 2 high-frequency motors and vertical/front rotating disc copiers.

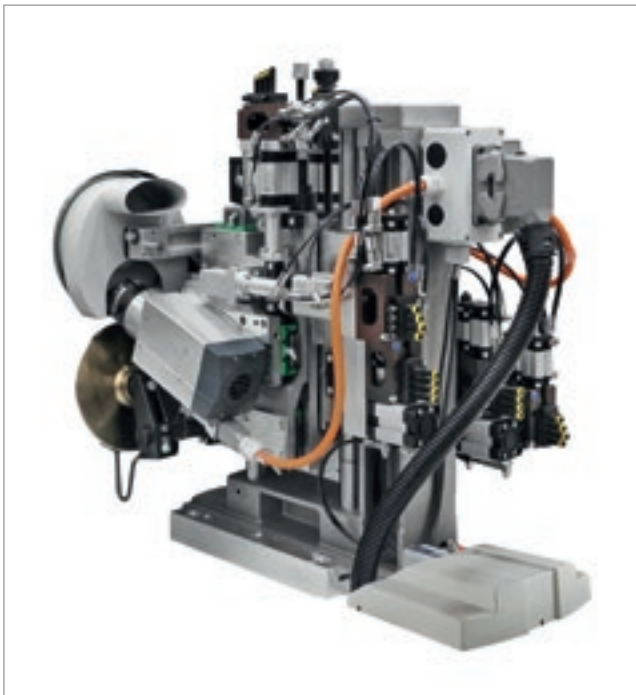
**RF30**

By using pneumatic revolvers, it can guarantee a quicker setting speed to move from one machining operation to another.



Hydraulic management of machining with 4 automatic tool profile settings.

**RF40**

Full machining setting autonomy. The ideal solution for users who require absolute machining flexibility, thanks to full adjustment of the machine to the required edge thickness.

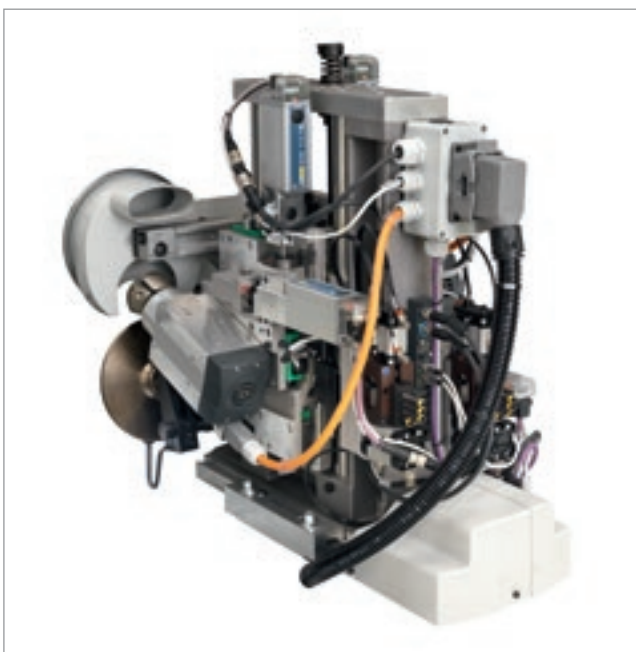

# Attention to detail

**Solution created to meet the productivity and flexibility needs of the most demanding manufacturers.**

The multi-function Corner Rounding Unit forms a radius on both the front/rear and top/bottom edges.



**AR30**  
2-motor pneumatic tracking corner-rounding unit.

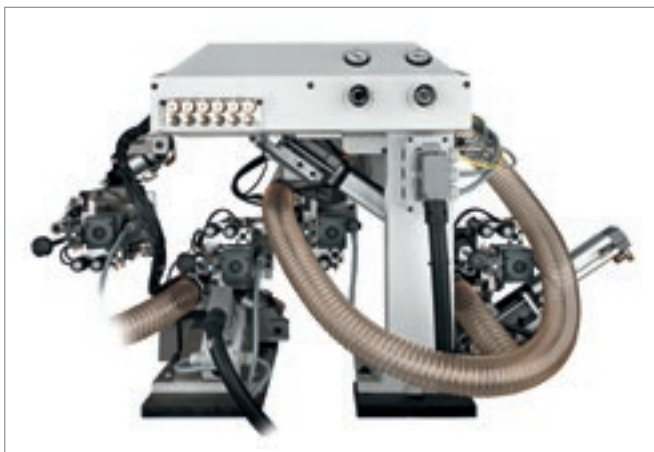

**AR34**  
4-motor pneumatic tracking corner-rounding unit. Ideal for rounding wood edges.



## AR80

2-motor corner-rounding unit with brushless movement for high machining speeds and maximum quality and precision.

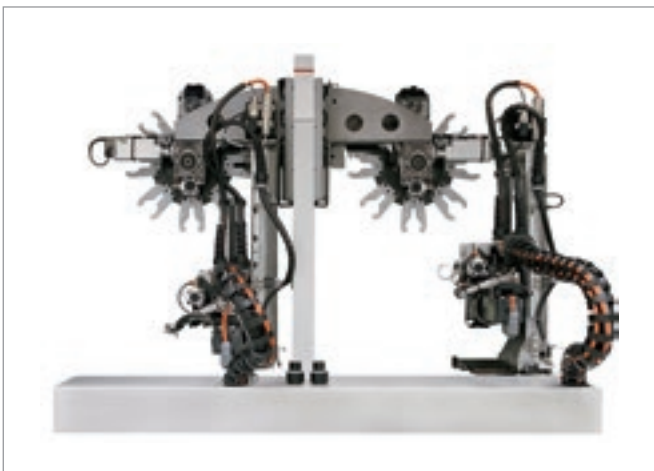
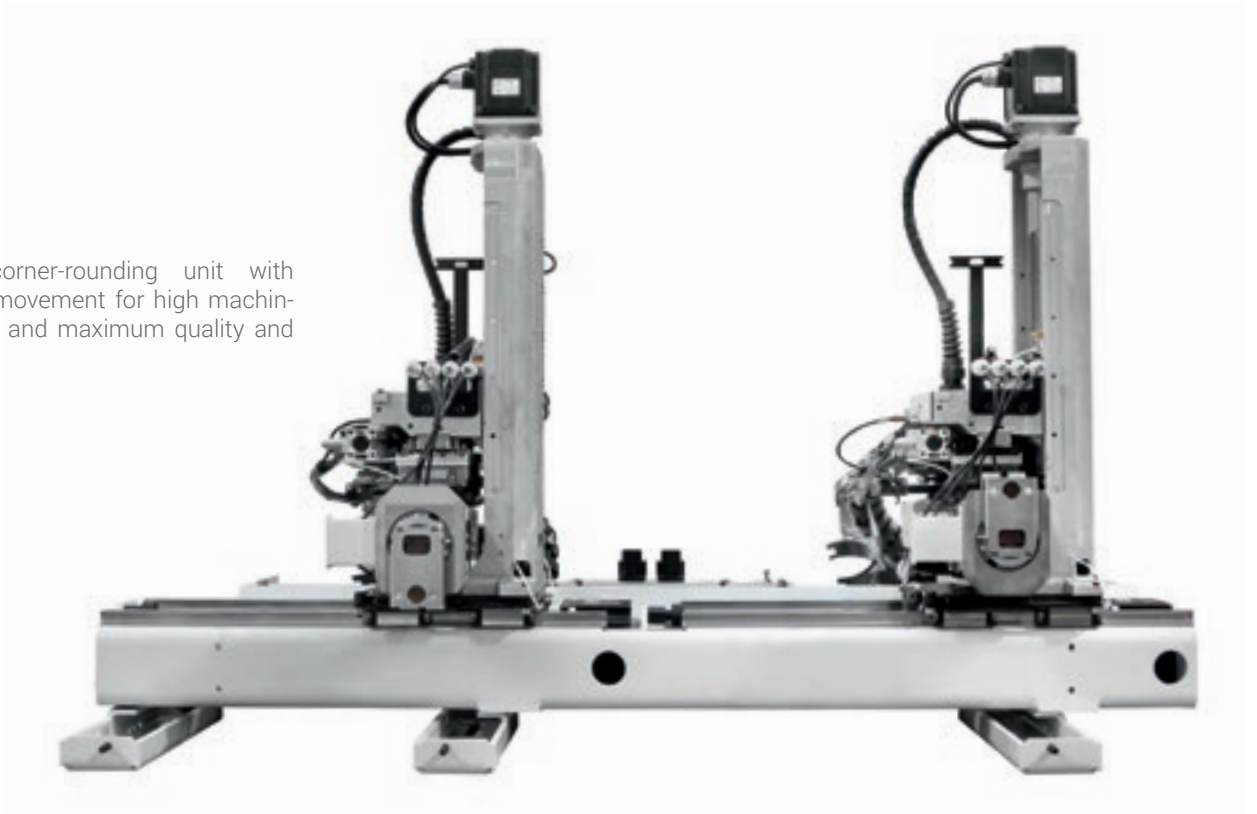

### Tool change magazine

Reduction in cycle times thanks to automatic tool change for machining edges of different thicknesses.



### Q-System

Q-System patented chuck with real-time profile change.



# 24/7 constant edgebanding



Stream B is an edgbanding machine that can be placed in a line system. Its excellent configurability and maximum customisation make it an ideal product that embodies Biesse's high engineering skills. Stream B can be set up to operate with a right-to-left or left-to-right flow. Stream B productivity on the loading/unloading line is much higher than a stand-alone solution both in terms of quality and performance. Stream B is the ideal solution for a company that wants to make the switch to Industry 4.0.



## EDGEBANDING LINE SOLUTIONS

No compromise on quality and productivity for consistent, excellent edgbanding. A perfect combination of Biesse technology and Italian genius.

# High-quality products

**Technological solutions designed for a perfect finish, for all machining operations.**

The Edge Scraper eliminates the imperfections resulting from previous machining operations on the top and bottom of the edge.



Compact machining unit with the management of 2 profiles with pneumatic settings.



## **Dual Profile Control**

The 4 pneumatic solenoid valves can be used to control the 2 different radius curves automatically.

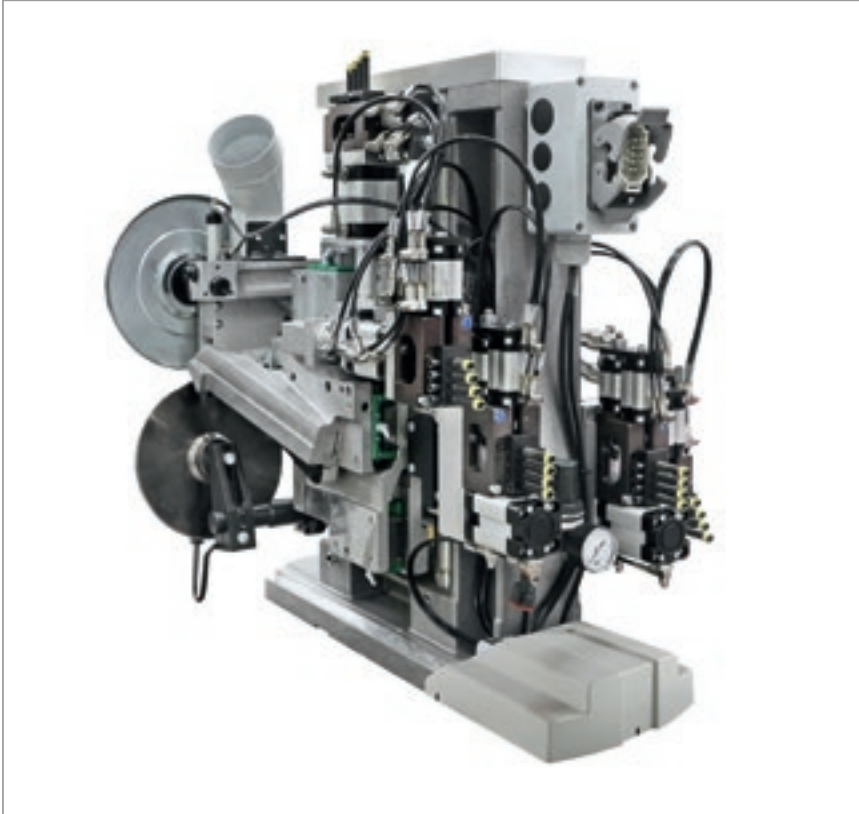

### RB30

Positioned on the column, it controls 4 automatic blade settings.



Automatic control of 4 different radius curves.

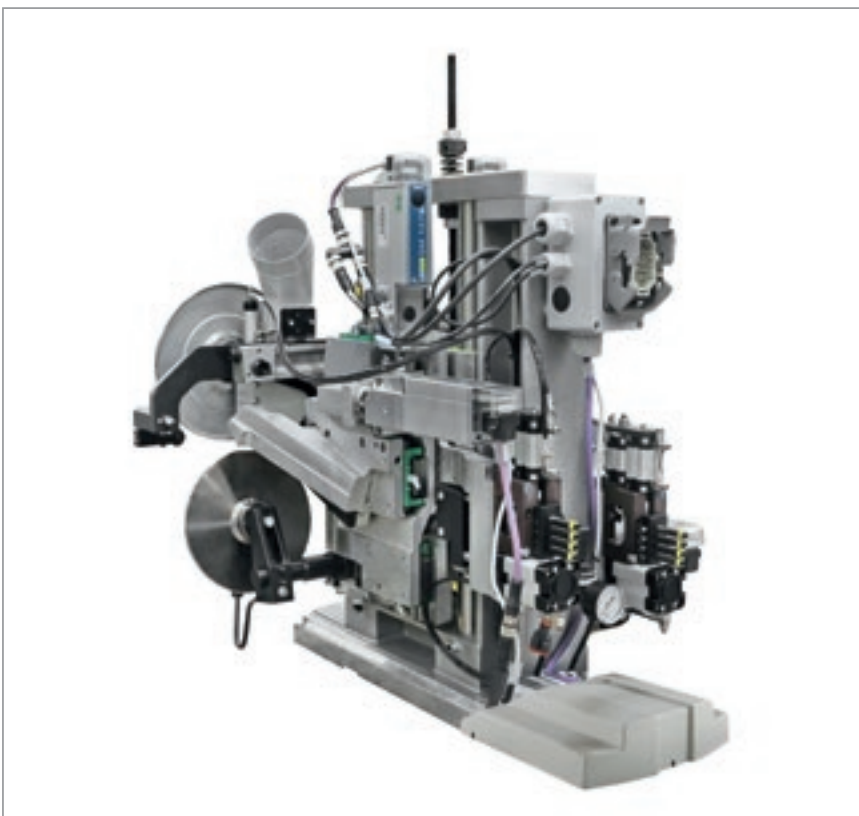

### RB40

Positioned on the column for the complete absorption of any vibration generated on the structure, with the multiple management of controlled-axis profiles for infinite settings.



### Pro-Nesting Kit

Ideal solution for edge banding of pre-drilled panels.

# A wide range of machining options

**Stream B technology can be used for complex machining, guaranteeing quality, precision and absolute reliability over time.**

The Grooving Unit can be used for grooving and milling on the bottom, top and front surface of the panel.



## **FB30**

Unit with manual movement and positioning of the unit with 0-90° rotation.



## **EB32**

Equipped with a double carriage to make a channel simultaneously on the bottom and front surface of the panel.



The motor can be replaced by an **electrospindle** for rapid blade changing.



**EB42**  
Maximum flexibility thanks to a dual electrospindle and fully controlled-axis setting management.

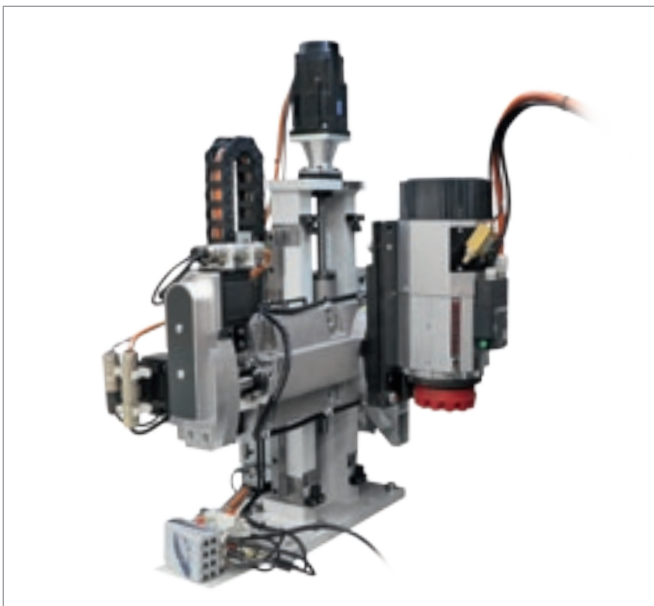

**EB60**  
Brushless servo-controlled axis electrospindle and grooving unit. It provides extreme precision in a timed drive context.  
The **Tool Magazine** has 5 compartments for automatic NC tool changing.

# Optimum cleaning of product

Multiple solutions for guaranteeing high quality product standards.

**Buffing unit** for cleaning and polishing the edge and panel.



The **Glue Scraper** removes excess glue from the top and bottom of the panel. This is the only model on the market fitted with 4 pneumatic cylinders for a top quality finish.



**Hot air blower** for reactivating the colour of the edges.



# Optimisation of stand-alone process



**PRS EKO panel return**  
+ 20% productivity in a stand-alone  
context. Management of entire  
edgebanding process with just one  
operator.

# Technology at our users' disposal

Immediate, user-friendly programming thanks to the touch-screen control panel.



19" control panel with SINTRA interface.

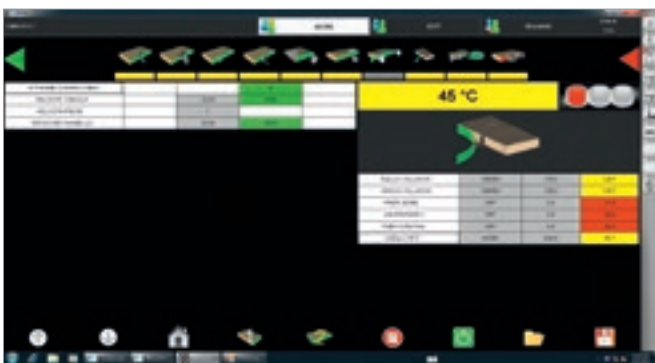

- ✓ Easy programme management and usability.
- ✓ Rapid transition from one machining operation to the next.
- ✓ Intelligent language management.



# Technical specifications

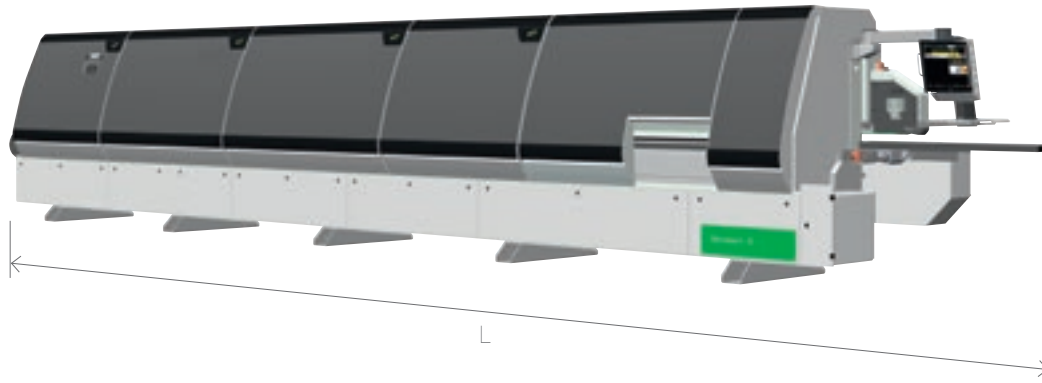

	L mm	L inch
Stream B 5.5	6640	261
Stream B 6.5	7640	301
Stream B 7.0	8140	320
Stream B 7.5	8640	340
Stream B 8.0	9140	360
Stream B 8.5	9640	380
Stream B 9.0	10140	399
Stream B 9.5	10640	419
Stream B 10.5	11640	458
Stream B 11.5	12640	498

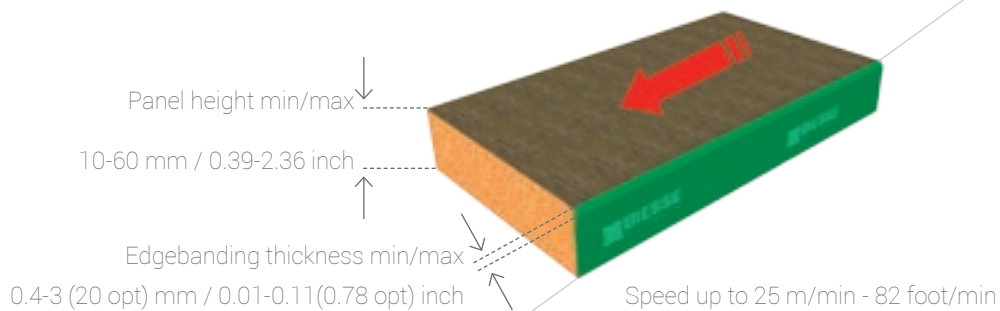

The technical specifications and drawings are non-binding. Some photos may show machines equipped with optional features. Biesse Spa reserves the right to carry out modifications without prior notice.

A-weighted sound pressure level (LpA) during machining for operator workstation on vane-pump machine LpA=86dB(A) Lwa=106dB(A) A-weighted sound-pressure level (LpA) for operator workstation and sound power level (LwA) during machining on cam-pump machine LpA=86dB(A) Lwa=106dB(A) K measurement uncertainty dB(A) 4

The measurement was carried out in compliance with UNI EN 848-3:2007, UNI EN ISO 3746: 2009 (sound power) and UNI EN ISO 11202: 2009 (sound pressure levels at workstation) during panel machining. The noise levels shown are emission levels and do not necessarily correspond to safe operation levels. Despite the fact that there is a relationship between emission and exposure levels, this may not be used in a reliable manner to establish whether further measures need to be taken. The factors determining the exposure level for the workforce include length of exposure, work environment characteristics, other sources of dust and noise, etc. i.e. the number of other adjoining machines and processes. At any rate, the above information will enable the operator to better evaluate dangers and risks.

# Service & Parts

Direct, seamless co-ordination of service requests between Service and Parts.  
Support for Key Customers by dedicated Biesse personnel, either in-house and/or at the customer's site.

## Biesse Service

- ✓ Machine and system installation and commissioning.
- ✓ Training centre dedicated to Biesse Field engineers, subsidiary and dealer personnel; client training directly at client's site.
- ✓ Overhaul, upgrade, repair and maintenance.
- ✓ Remote troubleshooting and diagnostics.
- ✓ Software upgrade.

500 / Biesse Field engineers in Italy and worldwide.

50 / Biesse engineers manning a Teleservice Centre.

550 / Certified Dealer engineers.

120 / Training courses in a variety of languages every year.

The Biesse Group promotes, nurtures and develops close and constructive relationships with customers in order to better understand their needs and improve its products and after-sales service through two dedicated areas: Biesse Service and Biesse Parts.

With its global network and highly specialised team, it offers technical service and machine/component spares anywhere in the world on-site and 24/7 on-line.



## Biesse Parts

- ✓ Original Biesse spares and spare kits customised for different machine models.
- ✓ Spare part identification support.
- ✓ Offices of DHL, UPS and GLS logistics partners located within the Biesse spare part warehouse, with multiple daily pick-ups.
- ✓ Order fulfilment time optimised thanks to a global distribution network with de-localised, automated warehouses.

87% / of downtime machine orders fulfilled within 24 hours.

95% / of orders delivered in full on time.

100 / spare part staff in Italy and worldwide.

500 / orders processed every day.

# Made **With** Biesse

## A new edgebanding system to ensure quality.

Closet America, a leading home and professional closet system manufacturer headquartered in Lanham, Maryland, is proud to be the first company in the United States to incorporate the Biesse AirForce edgebanding system into its production line. "In our efforts to provide our customers with a high-quality, customised closet system along with our top-notch customer service, we were excited to invest in the Biesse AirForce system. Closet America is known for

our quality closet design, our superior product and expert installation. Our investment in the AirForce system, coupled with the use of Rehau's LaserEdge edgebanding material, is another step towards continuously exceeding our customers' expectations". The AirForce system enables companies to exploit the sustainability benefits provided by the excellent range of laser edgebands with invisible glue line. AirForce emits compressed air at a very high temper-

ature from a special nozzle directly onto the reactive layer of the laser edgeband, thus activating the layer and welding the edgeband to the substrate. Installing the new Stream A together with AirForceSystem will result in a product of an exceptional quality, apart from contributing to increasing manufacturing speed".

*Skip Labella  
President of Closet America*



# Biesse Group

In

1 industrial group, 4 divisions  
and 8 production sites.

How

€ 14 million p/a in R&D and 200 patents registered.

Where

34 branches and 300 agents/selected dealers.

With

customers in 120 countries (manufacturers of furniture, design items and door/window frames, producers of elements for the building, nautical and aerospace industries).

We

3,200 employees throughout the world.

**Biesse Group** is a multinational leader in the technology for processing wood, glass, stone, plastic and metal.

Founded in Pesaro in 1969, by Giancarlo Selci, the company has been listed on the Stock Exchange (STAR segment) since June 2001.

 **BIESSEGROUP**

 **BIESSE**

 **INTERMAC**

 **DIAMUT**

**MECHATRONICS**

