



Edge banding machines Highflex 1220 - 1890 KDN/F 1630 - KDN/F 1895 profiLine



A member of the Homag Group of Companies



BRANDT Kantentechnik GmbH

Weststraße 2
32657 Lemgo
Germany
Tel. +49 5261/974-0
Fax +49 5261/6486
info@brandt.de
<http://www.brandt.de>

PRACTIVE

Intelligent woodworking solutions

HOMAG Group

Success through partnership

To survive in a fiercely competitive market, a company has to have fast, flexible and efficient production. The HOMAG Group, with its sales and service network in over 90 countries around the world, offers you and your employees a strong partnership no matter where you are.

The HOMAG Group of companies cover all areas of woodworking and wood-processing. Panel sizing, sawing, edge technology, transportation technology and handling systems are just a few of our specialties. We also offer solutions for drilling, coating technology, surface technology, plants for doors and doorframes, timber house

construction, sanding technology, automation systems, packaging equipment and software. We provide a complete and innovative range of products and services that are always the perfect solution for any requirement. You, our customers, benefit from high precision, performance and cutting-edge technology.

BRANDT

Perfect edges for demanding customers

We offer our customers innovative and powerful edge banding machines. Efficiency and quality have the highest priority, and ensure long-term competitive advantages for you. With an annual production of over 2000 edge banding machines, we are the edge banding specialist in the HOMAG Group and the world leader in our market segment.

A high degree of standardization in combination with an advanced manufacturing process and more than 50 years of engineering experience ensure state of the art quality at a superb price-performance ratio. Our clear and structured product range is designed to

meet the demands of current and future market trends. All of our developments are focused toward practically-oriented and economic solutions that guarantee you the best possible production results.



"With us, you and your products come first. A promise that you can count on!"

Highflex & profiLine series

Precision and performance for the most demanding jobs

The Highflex series is characterized by its high degree of automation and well equipped units. This high level of flexibility allows perfect focus on your needs and guarantees perfect edges.

Because of its modular design and the freely-fittable frame concept, it is possible to configure perfectly tailor-made machines according to specific requirements.

The characteristics of all BRANDT machines are combined in these two series to make them perfectly-equipped for any job

The right solution for your requirements

The Highflex & profiLine series machine leaves nothing lacking. Whether your needs are "batch size one" production, for demanding bespoke shop fitting applications, living & bedroom furniture or functional office furniture, the Highflex & profiLine Series always offers the right solution for your requirements.



Optimal preparation for a perfect result. Highflex 1220 + 1230



Contact heating shoe

As standard, all machines of the 1200 series are equipped with a contact heating shoe that – optionally activated – transfers contact heat into the board edge directly prior to the glue application to the workpiece edge, this notably optimising the gluing quality, especially with difficult edging materials or at very low ambient temperatures.

The controller – Quality and precision with the touch of a button. Highflex 1220 + 1230

Through targeted and constant development of controller technology, simple operation and a high operating comfort are guaranteed. At BRANDT we focus on you as our customer and your finished product.



easyControl EC 10+, offering every "plus" for the customer

- + High operating convenience through simple menu format and optimized linepoint adjustment.
- + Fast access to all unit functions through dedicated control buttons.
- + Quick change over to different edge banding material through user-defined programs.
- + Easy to read large 4-line operating display
- + Clear text error diagnostics provide high operating convenience

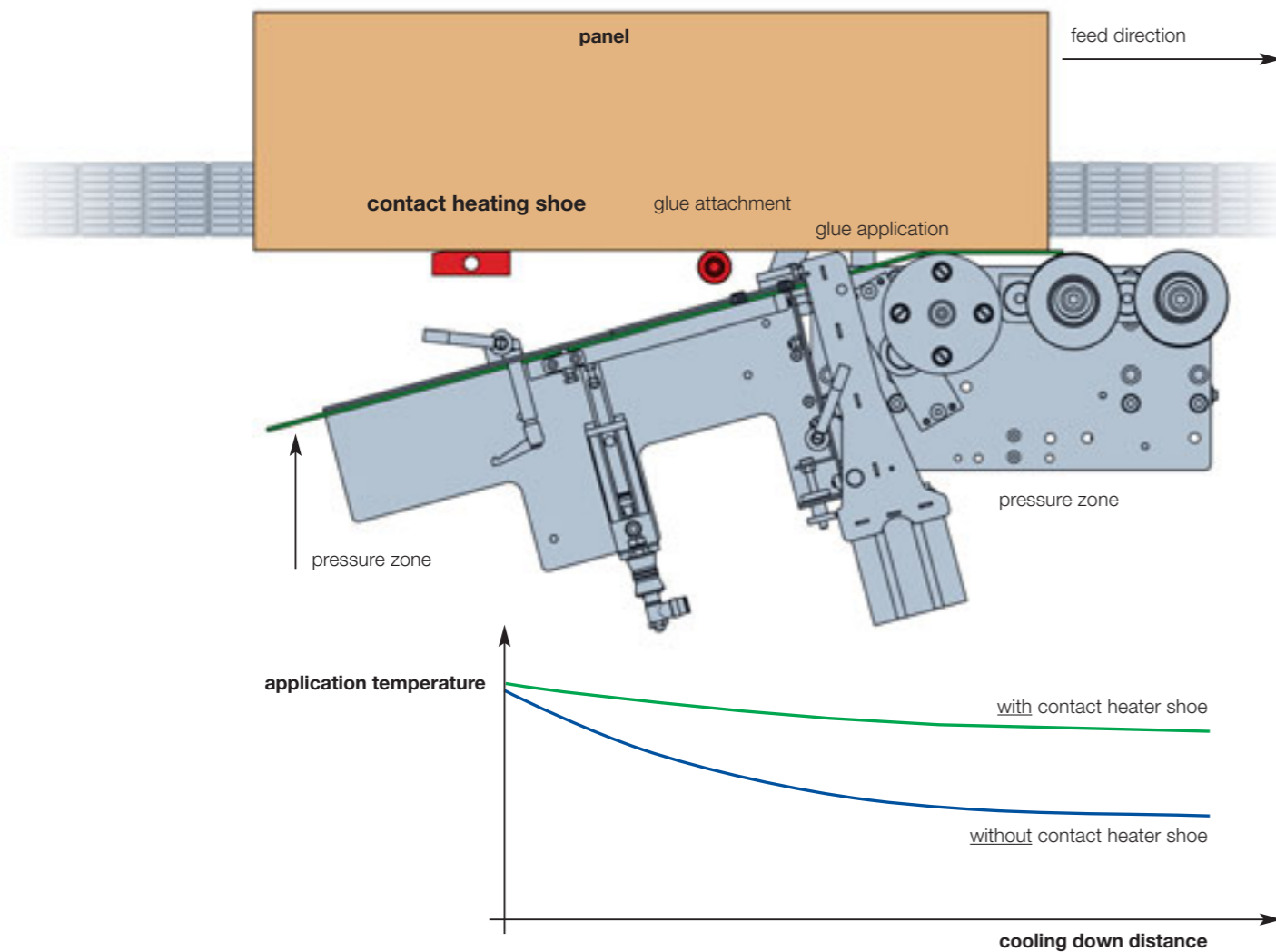

Significant competitive advantages – Pace setting performance and quality. Highflex 1220 + 1230



Joint trimming unit

Perfect cut and high operating life due to diamond tipped tools for an optimum edge joint quality.

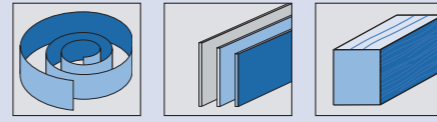
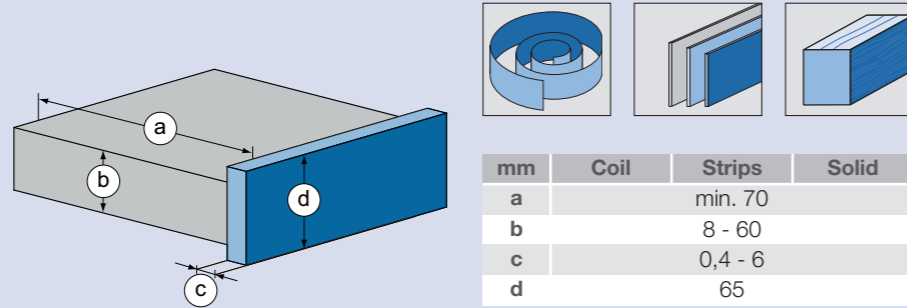

mm	Coil	Strips	Solid
a		min. 70	
b		8 - 60	
c		0,4 - 6	
d		65	



Spraying unit (optional)

Separation and detergent agents for a perfect finish when processing PU-glue.



Automatic edge infeed device (optional)

Automatic edge infeed device for fast change over between different coiled materials.

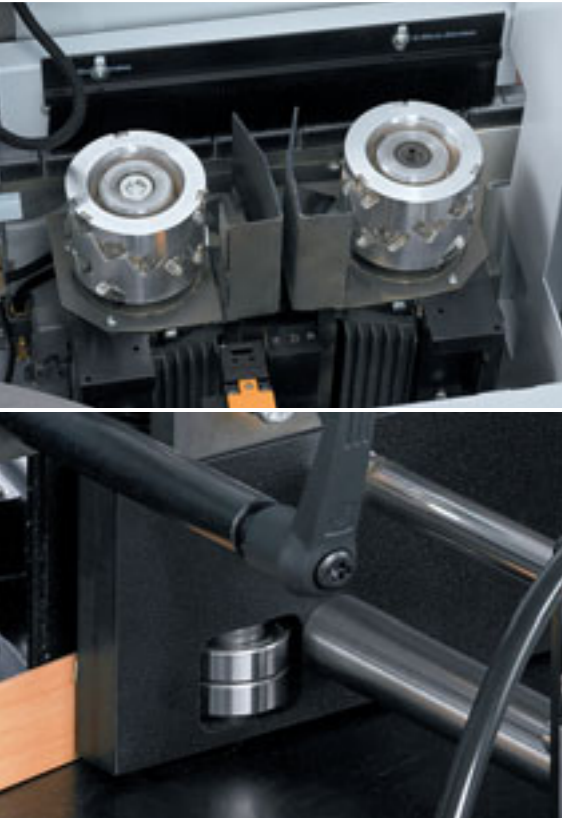

Counter pressure device

Counter pressure device magazine for sensitive edges.

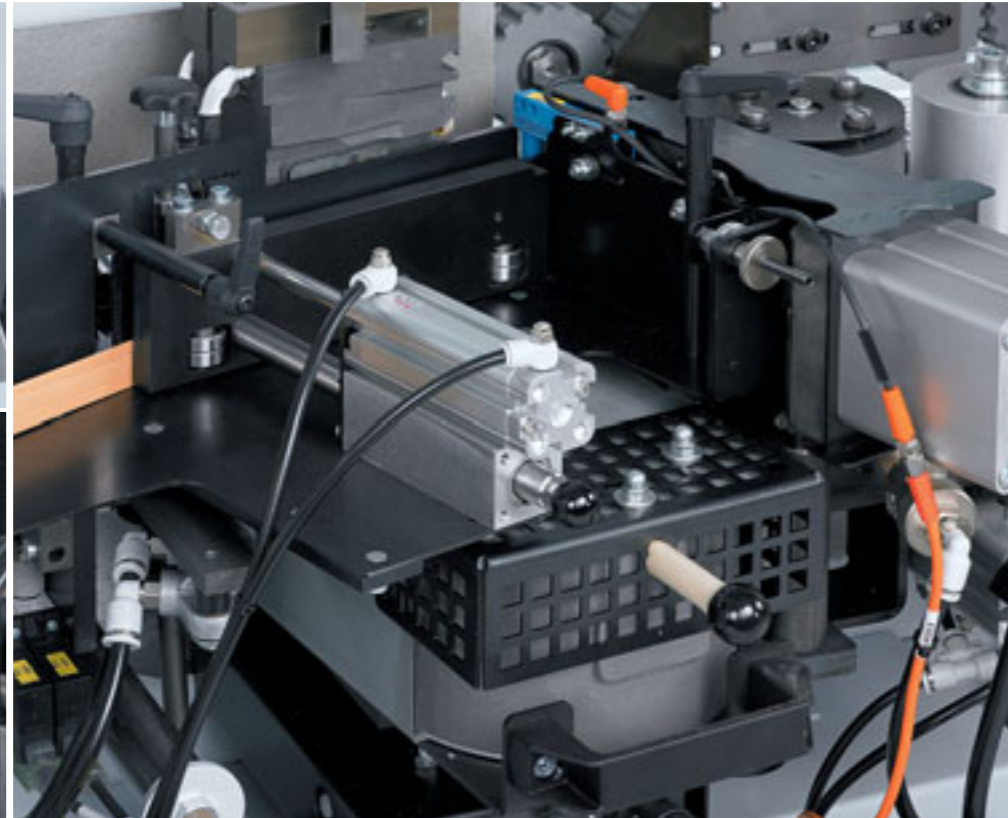

Gluing unit and magazine

Coil and automatic strip magazine for a reliable edge material supply. Optimal glue joints, by controlling the exact amount of glue.



Pressure zone

Heavy pressure zone up to 6 mm edge thickness and 60 mm workpiece height for an optimal glue joint.

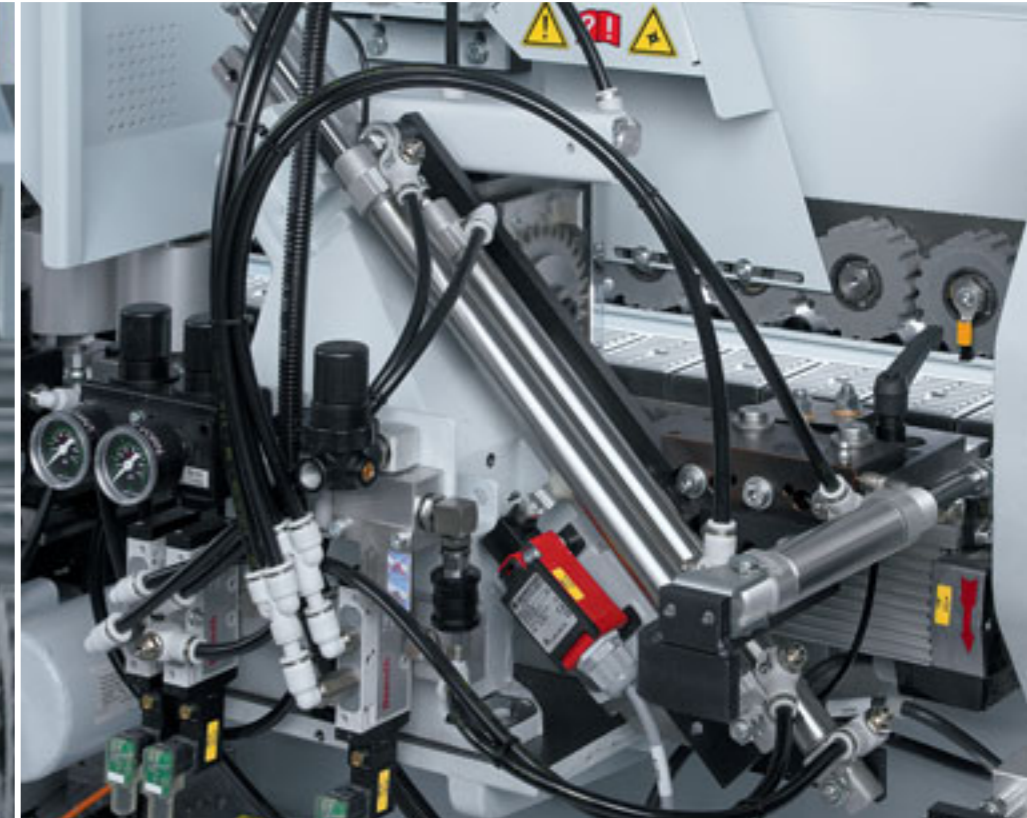

End-trimming unit

Precise end-cut through a strong end-trimming unit, equipped with THK guides. Chamfer/straight adjustment by easily tilting the unit. Pneumatic adjustment.

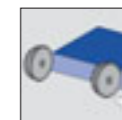

**Significant competitive advantages –
Pace setting performance and quality.
Highflex 1220 + 1230**



Central lubrication unit

To lubricate the feed track guidance system to guarantee precision and a long life of the conveyor chain.

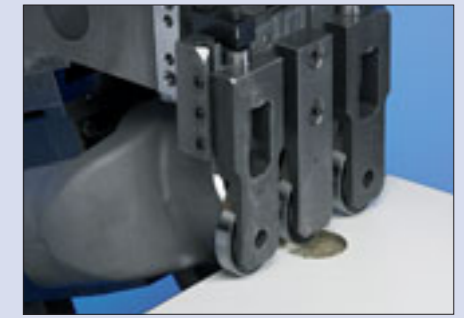

Nesting package (optional)

Includes a multi-roller tracing device for the trimming and scraping units to compensate for hinge holes.



**Glue joint scraping unit
(optional Highflex 1220)**

For the perfect finish.



**Trimming unit with pneumatic
3-point adjustment**

For even more effective production and much shorter changeover time.

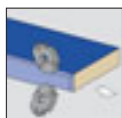

Corner rounding unit FF 10

Optimum corner rounding without adjustment or set-up, resulting from the coupled diamond tool and tracer roller. Workpiece thickness up to 40 mm. Workpiece thickness 60 mm - Highflex 1230.

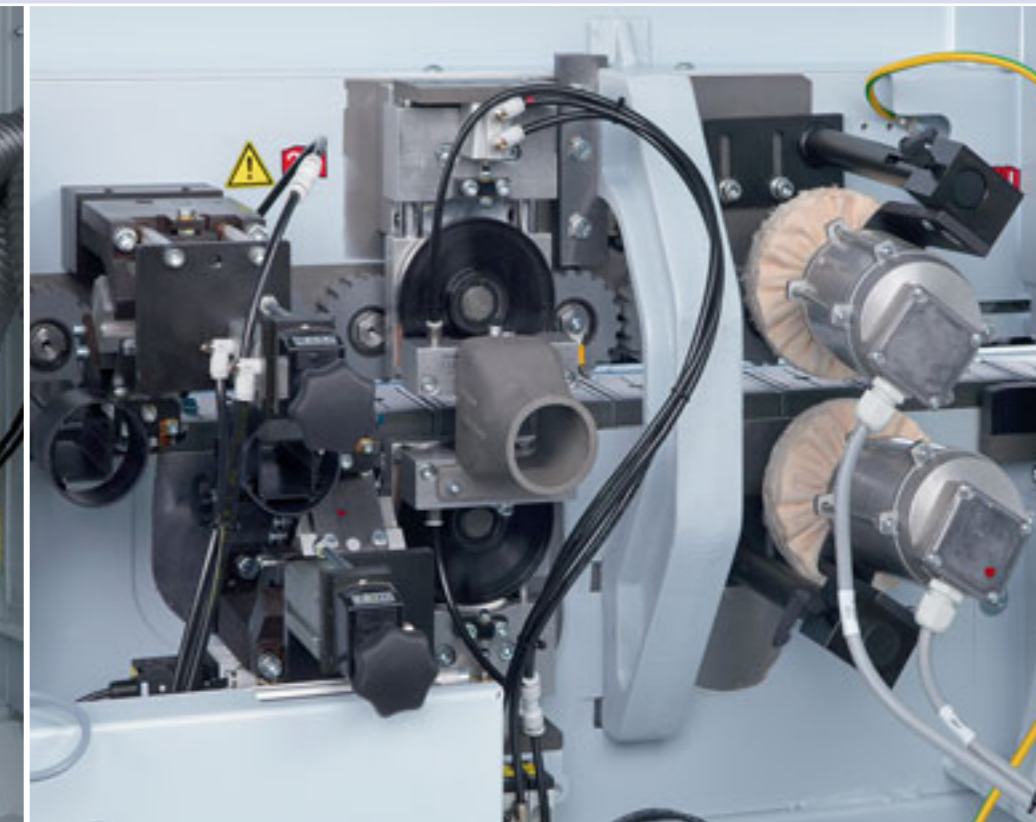

Profile scraping unit

To smooth radii or chamfers (Pneumatic adjustment optional).



Buffing unit

Buffing unit to polish edges and maintain their natural colour.

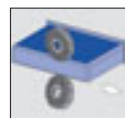

The controller – Quality and precision with the touch of a button. Highflex 1430 - 1880 and profiLine

Through targeted and constant development of controller technology, simple operation and a high operating comfort are guaranteed. At BRANDT we focus on you as our customer and your finished product.

PowerControl PC 20+, offering every "plus" for the customer

- + Optimum overview by using an easy to view 12" screen
- + High operator comfort with all functions button-controlled from the operating panel
- + Short set up times, through high controller capacity and easy selection of processing programs
- + Self-explanatory operator guidance, through a graphic interface and optimum visualisation
- + Network-compatible
- + Context-sensitive help - detailed information about the functions and how to operate the machine directly on the screen
- + Compilation of production data for detailed gathering of job related costs

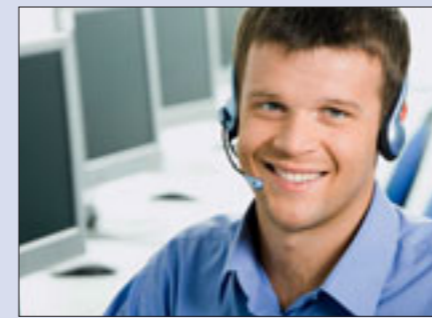

Teleservice reduces field service work operations

- Reduction of service cost
- Avoidance of an unscheduled machine downtime
- Specific scheduling of field service work + spare parts
- Support to maintenance and operation staff



Machine	0281-205479				
Date	10.05.2011				
Time	06:49:12				
Production order	Kommission Test Kuechen				
Operator	SM				
Additional info	Kommentar:				
Program	programm2				
Date	10.05.2011	10.05.2011	10.05.2011	10.05.2011	10.05.2011
Start time	06:49:20	06:49:50	06:50:02	06:50:15	06:50:28
Stop time	06:49:39	06:49:51	06:50:05	06:50:18	06:50:21
Hours per day	0:00	0:00	0:00	0:00	0:00
Workpieces per day	0:0	0:0	0:0	0:0	0:0
Edge length per day	0:0	0:0	0:0	0:0	0:0
Program	programm2				
Date	10.05.2011				
Start time	06:49:43				
Stop time	06:49:56				
Hours per day	06:50:09				
Workpieces per day	06:50:22				
Edge length per day	06:50:35				

Compilation of production data via the BRANDT-Browser

Compiled production data can be easily gathered and saved. The BRANDT-Browser allows for job-specific collection of operating hours, an overview of the total processed workpieces and information regarding total meters of processed edges. For companies that have large numbers of different clients, it is especially advantageous to always have an accurate record of contract-related costs.

BRANDT		4.2.2
PC 2X machine control unit		
The PC 2X is a graphics-oriented, point text input device. Units can be switched on and pre-selected. Various operating scenarios can be stored as programs and opened again later.		
Features	Values	
Screen	12.1"	
RTD	800 x 600 dots	
Memory	2 GB	
RS 232 interfaces	4	
Module	processor	800 MHz
RAM	256 MB	
Operating system	Linux	

Context-sensitive help

With the context-sensitive help function, it is possible to directly display detailed information on the operations and functions of the machine. The controller-integrated help functions are accessible with the push of a button from the keyboard and allow for immediate operator support.



Easy Back-up function of the entire control and all operator programs

Significant competitive advantages – Pace setting performance and quality. Highflex 1430 + 1440

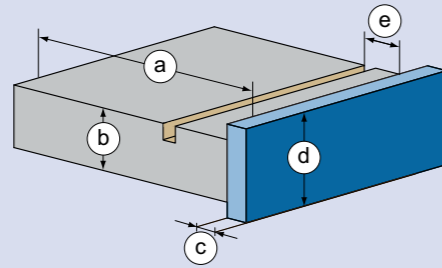

mm	Coil	Strips	Solid
a		min. 70	
b		8 - 60	
c		0,4 - 8	
d		65	
e		max. 30	



Joint trimming unit

Perfect cut and high operating life due to diamond tipped tools for an optimum edge joint quality.

Pre-melter

On-demand availability and perfect glue quality with Quickmelt.

Gluing unit and magazine

Coil and automatic strip magazine for a reliable edge material supply. Optimal glue joints, by controlling the exact amount of glue.



Spraying unit (optional)

Separation and detergent agents for a perfect finish when processing PU-glue.



Infeed stop

For minimum workpiece spacing and safe operation.



Automatic edge infeed device (optional)

Automatic edge infeed device for fast change over between different coiled materials.



Rough trimming unit

For rough trimming of all common edge banding materials.



Radiant heater

Strong adhesion through optimal pre-heating of the workpiece.



Counter pressure device

Counter pressure device magazine for sensitive edges.

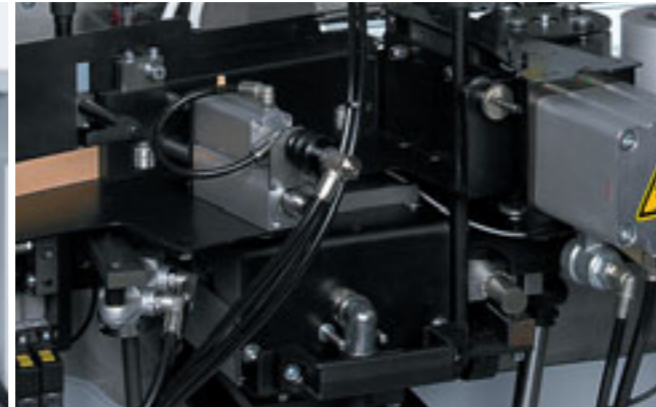

Pressure zone

Heavy pressure zone up to 8 mm edge thickness and 60 mm workpiece height for an optimal glue joint.



End-trimming unit

Precise end-cut through a strong end-trimming unit, equipped with THK guides. Chamfer/straight adjustment by easily tilting the unit. Pneumatic adjustment.

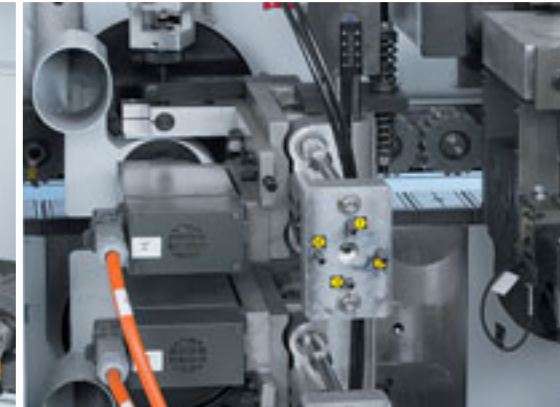
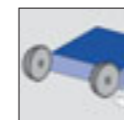

Trimming unit

Flexible adaptation to different edge thicknesses and profiles through servo axes.



Multistage trimming unit MS 40/45 (optional)

Fully automatic adjustment between 3 different profiles by means of servo motors.

Significant competitive advantages – Pace setting performance and quality. Highflex 1430 + 1440



Pressure beam adjustment with servo motor

Motor controlled guidance, to exactly match workpiece thickness.



Central lubrication unit

To lubricate the feed track guidance system to guarantee precision and a long life of the conveyor chain.



Nesting package (optional)

Includes a multi-roller tracing device for the trimming and scraping units to compensate for hinge holes.



Profile scraping unit

Unit to smooth radii or chamfers, equipped with quick change heads for fast profile change.



Corner rounding unit FF 10 (Highflex 1430)

Optimum corner rounding without adjustment or set-up, resulting from the coupled DIA tool and tracer roller. Workpiece thickness up to 60 mm.



Multifunctional trimming unit MF 50 (Highflex 1440)

Trimming of the edge overhang on top and bottom side as well as contour trimming on the front and rear edges. Equipped with an automatic adjustment to switch between thick and thin edges. Workpiece thickness up to 60 mm.

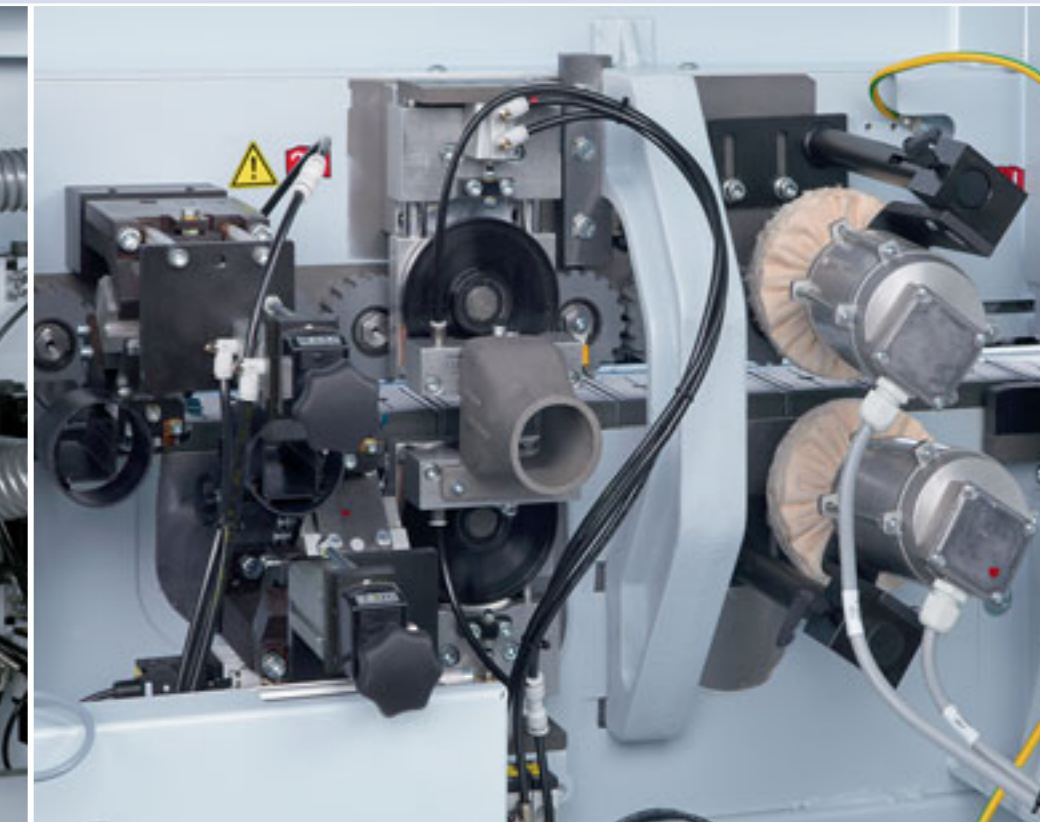

Glue joint scraping unit

For the perfect finish.

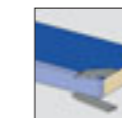

Buffing unit

Buffing unit to polish edges and maintain their natural colour.

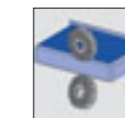

Significant competitive advantages – Pace setting performance and quality. Highflex 1650 + 1660

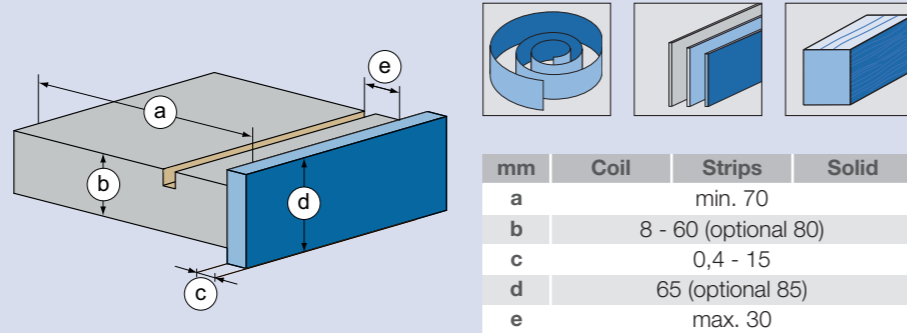

Joint trimming unit

Perfect cut and high operating life due to diamond tipped tools for an optimum edge joint quality.

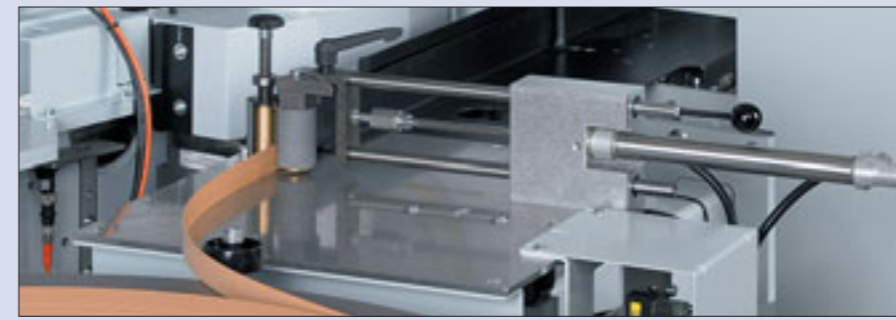

Automatic edge infeed device (optional)

Automatic edge infeed device for fast change over between different coiled materials.



V-belt top pressure (optional)

Top pressure V-belt system optionally available instead of the standard top pressure roller system.

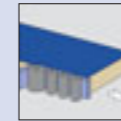

Pressure zone

Heavy pressure zone (up to 15 mm) to ensure an optimum glue joint quality.



Rough trimming unit

For rough trimming of all common edge banding materials.

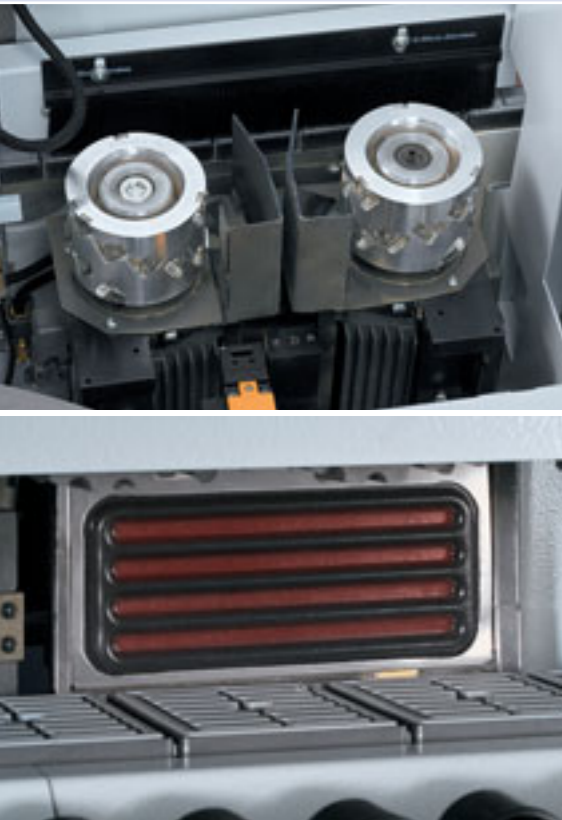

Radiant heater

Strong adhesion through optimal pre heating of the workpiece.

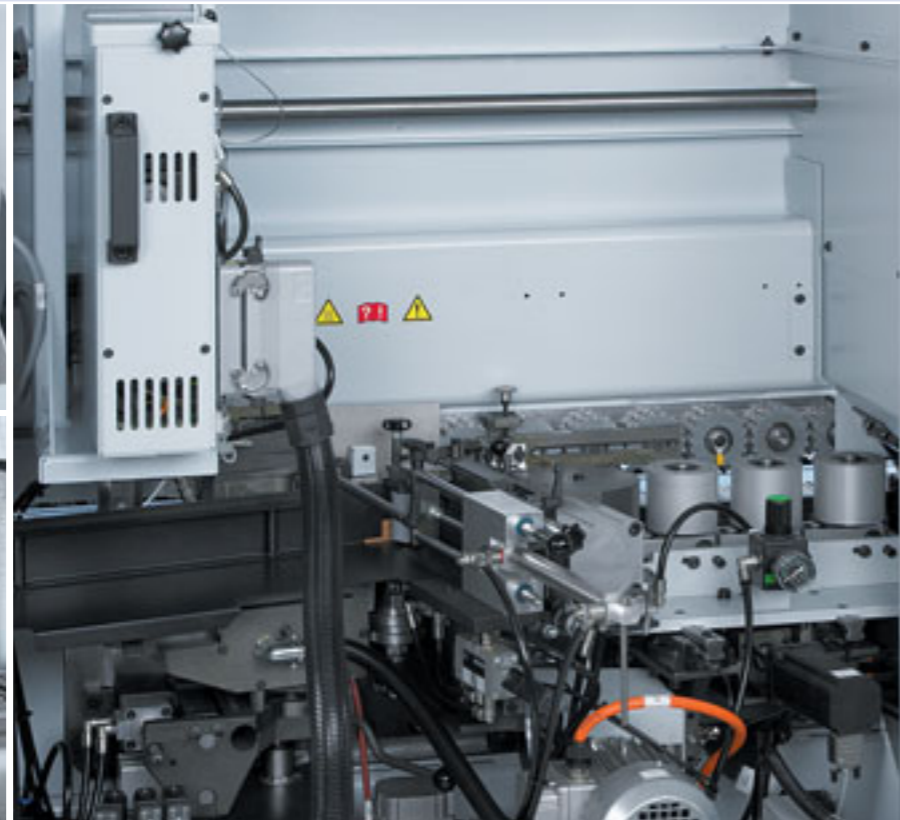

Magazine + pre-melter (optional)

Coil and automatic strip magazine with optical monitoring for reliable material supply, high availability and perfect glue quality via the Quickmelt gluing unit.

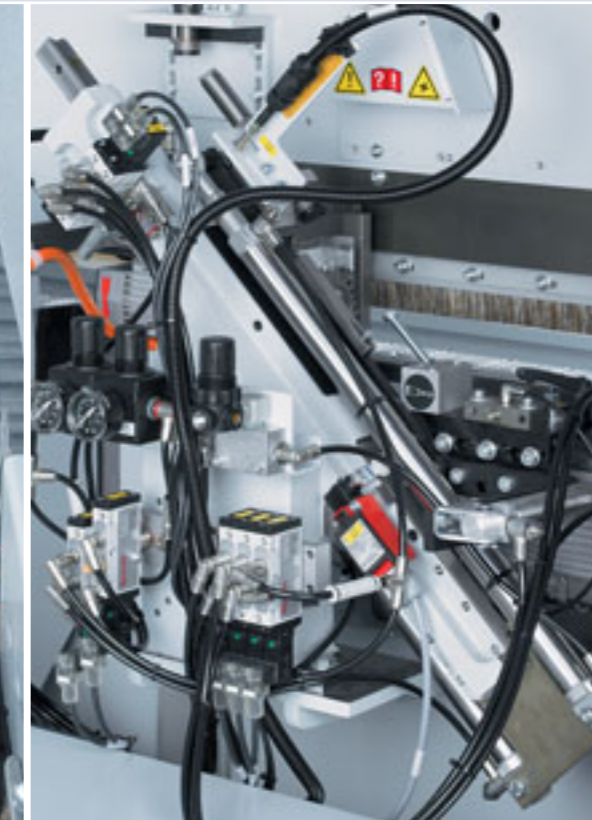
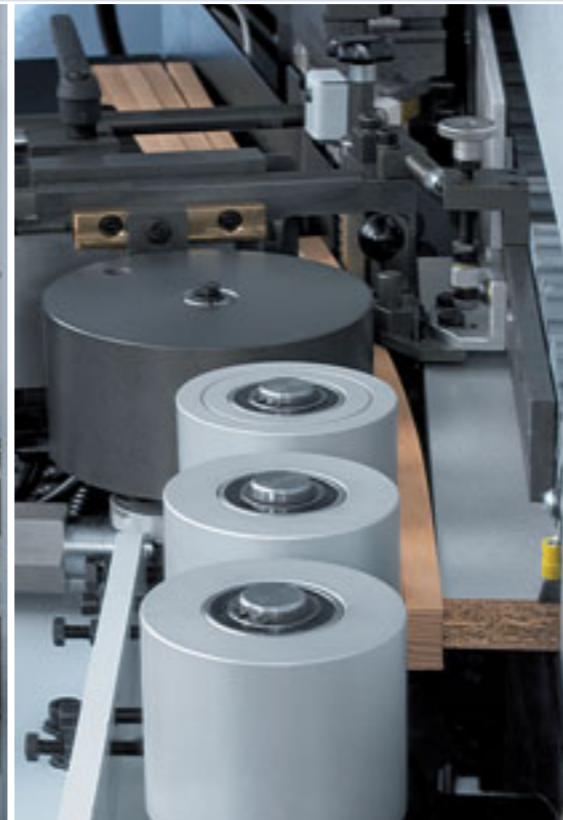

End trimming unit

Perfect cutting by the end trimming unit using rigid high-precision linear guides and the workpiece gap optimization (optional) package to achieve higher output in the same processing time. Soft-touch for optimal end trimming results even at high speeds.

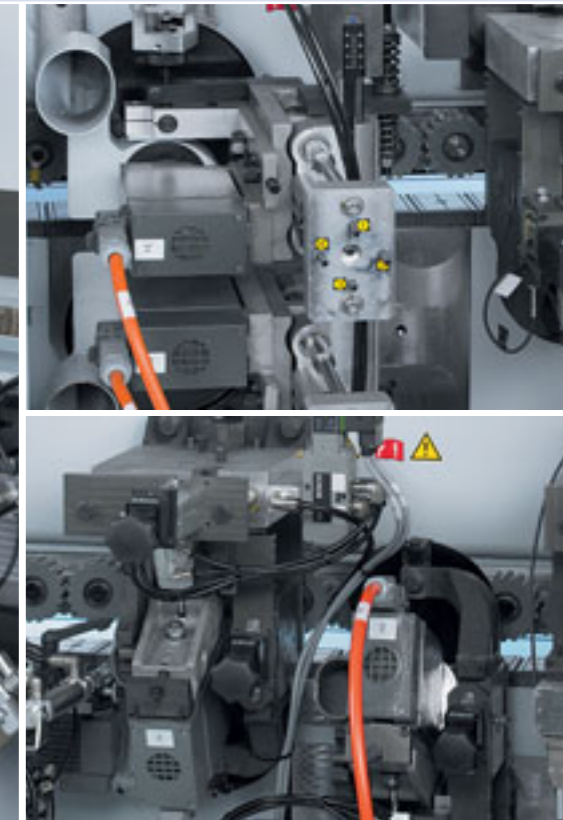

Trimming unit

Trimming unit with DFC (Dust Flow Control) tooling technology for optimal extraction. Optional pneumatic or servo axis adjustment available.

Multistage trimming unit MS 40/45 (optional)

Fully automatic adjustment between 3 different profiles by means of servo motors.

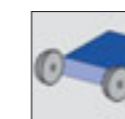

Significant competitive advantages – Pace setting performance and quality. Highflex 1650 + 1660



Spraying unit (optional)
Separation and detergent agents for a perfect finish when processing PU-glue.



Central lubrication unit
Fully automatic lubrication of the feed track guidance system to guarantee precision and a long-life time of the conveyor chain.



Nesting package (optional)
Includes a multi-roller tracing device for the trimming and scraping units to compensate for hinge holes.

Multistage technology

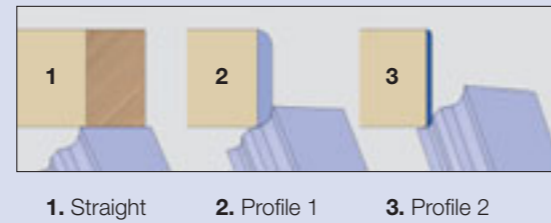

Profile scraping unit
Unit to smooth radii or chamfers, equipped with quick change heads for fast profile change.



Buffing unit
Buffing unit to polish edges and maintain their natural colour.



Multifunctional trimming unit MF 50
Trimming of the edge overhang on top and bottom side as well as contour trimming on the front and rear edges. Equipped with an automatic adjustment to switch between thick and thin edges. Workpiece thickness up to 60 mm.

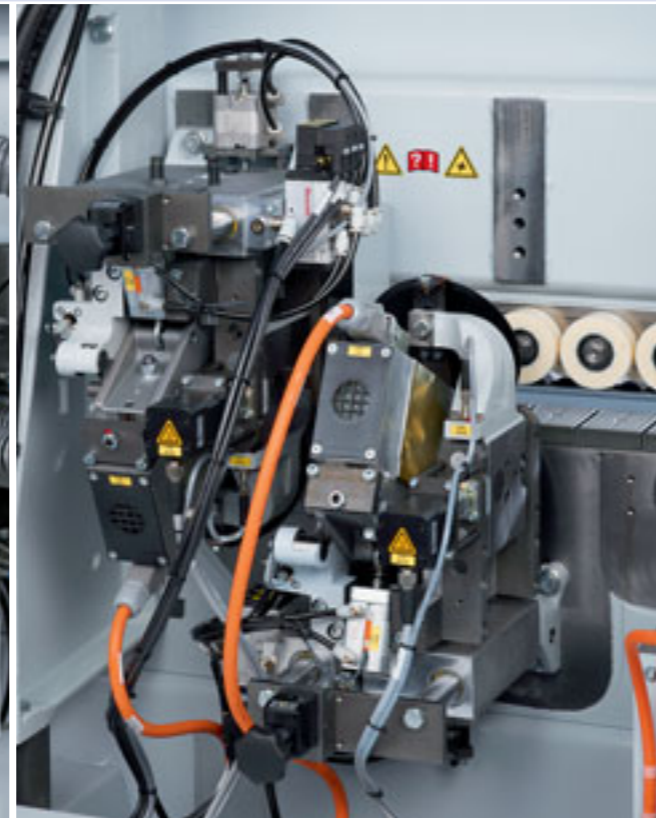

Multistage trimming unit MS 40/45 (optional)
Fully automatic adjustment between 3 different profiles by means of servo motors.

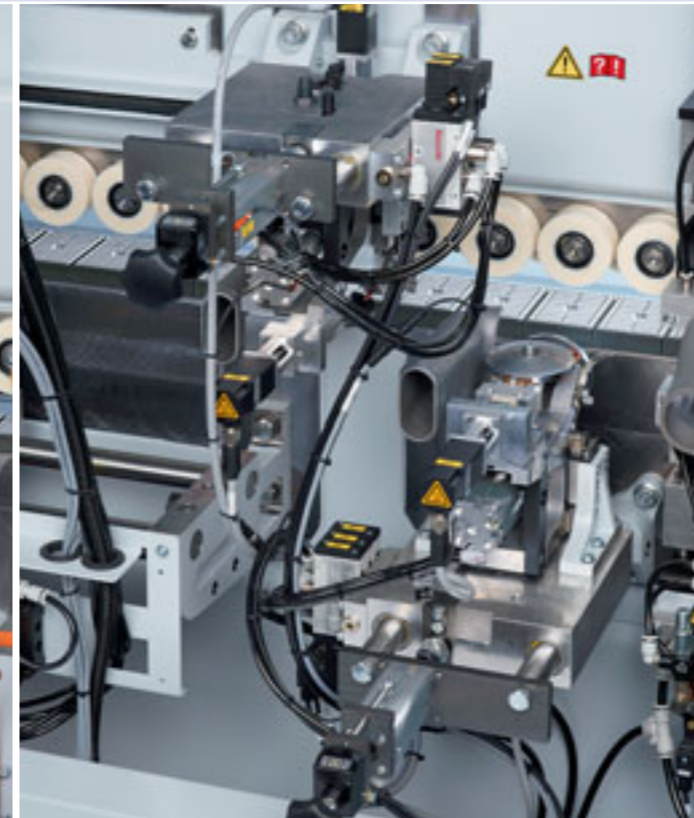

Multistage scraping unit MZ 40 (optional)
Fully automatic adjustment between 2 different profiles by means of servo motors.

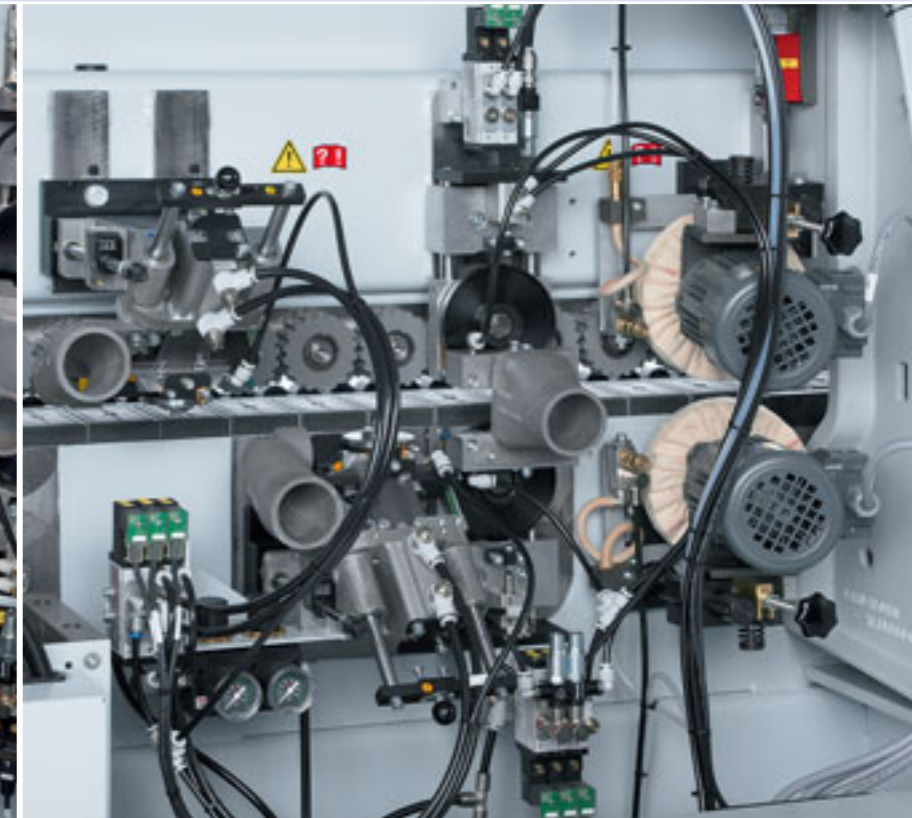

Glue joint scraping unit
For the perfect finish.



Significant competitive advantages – Pace setting performance and quality. Highflex 1870 + 1880



Joint trimming unit

Perfect cut and high operating life due to diamond tipped tools for an optimum edge joint quality.

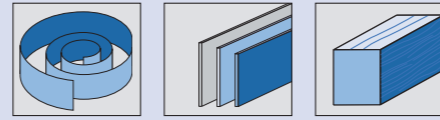
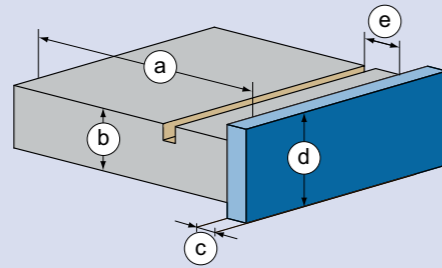

mm	Coil	Strips	Solid
a	min. 70		
b	8 -60 (optional 80)		
c	0,4 - 15 (optional 20)		
d	65 (optional 85)		
e	max. 30		



Infeed stop

For minimum workpiece spacing and safe operation.

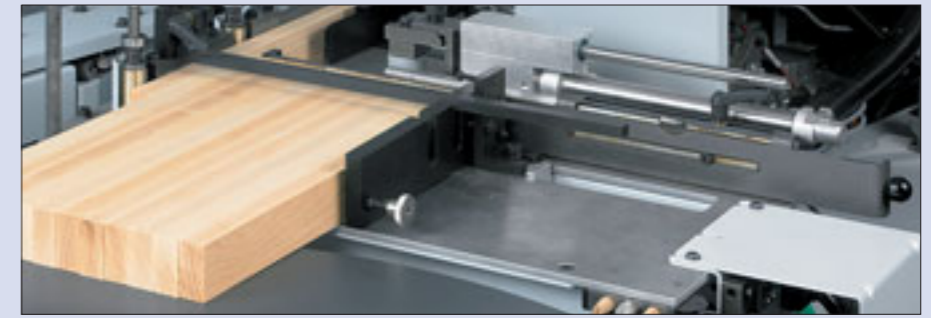

Extra wide magazine (optional)

Extra wide magazine with high capacity for fixed length strips and optimum access to reload.

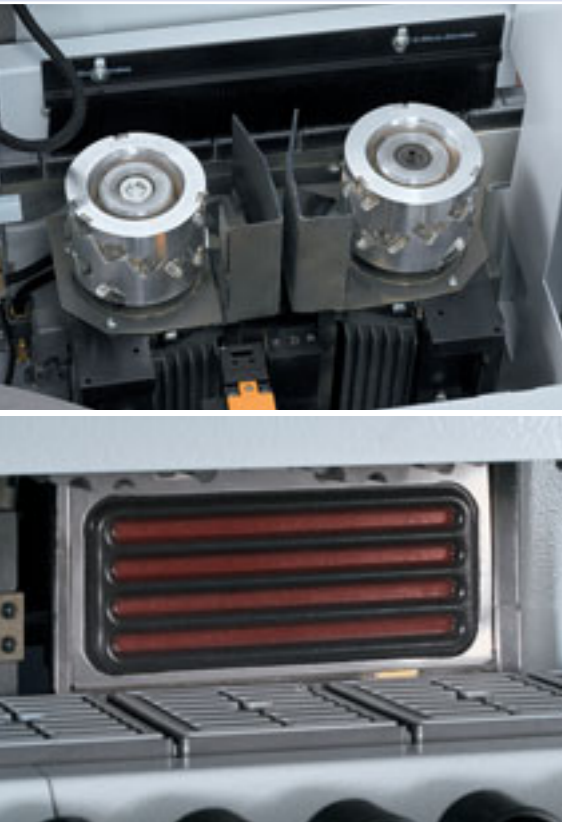

Radiant heater

Strong adhesion through optimal pre heating of the workpiece.

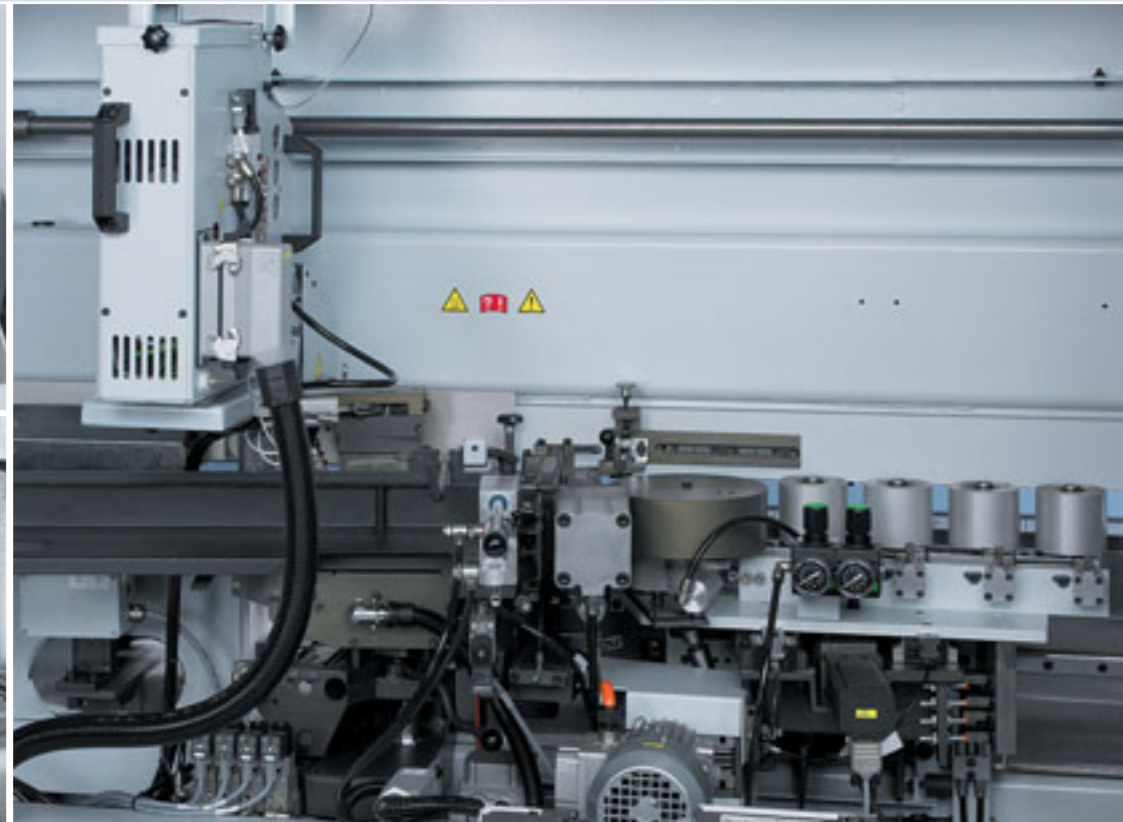

Magazine + pre-melter (optional)

Coil and automatic strip magazine with optical monitoring for reliable material supply, high availability and perfect glue quality via the Quickmelt gluing unit.



Pressure zone

Heavy pressure zone (up to 20 mm) to ensure an optimum glue joint quality.

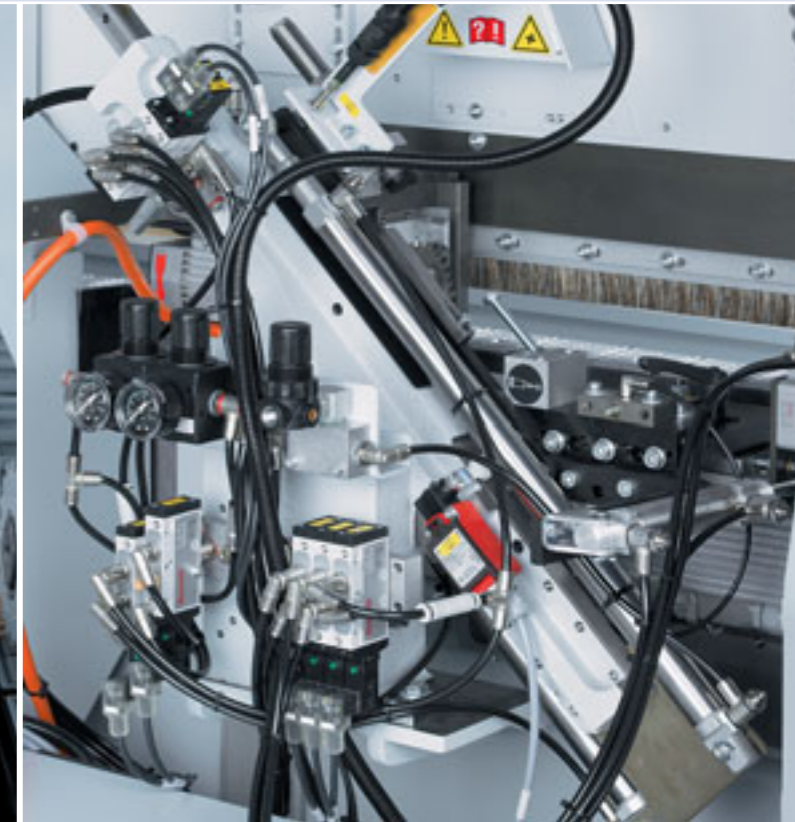

End trimming unit

Perfect cutting by the end trimming unit using rigid high-precision linear guides and the workpiece gap optimization package to achieve higher output in the same processing time. Soft-touch for optimal end trimming results even at high speeds.

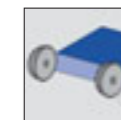
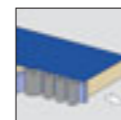

Significant competitive advantages – Pace setting performance and quality. Highflex 1870 + 1880



Spraying unit (optional)

Separation and detergent agents for a perfect finish when processing PU-glu.



Central lubrication unit

Fully automatic lubrication of the feed track guidance system to guarantee precision and a long-life time of the conveyor chain.

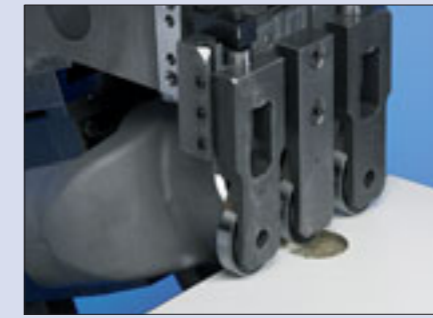

Nesting package (optional)

Includes a multi-roller tracing device for the trimming and scraping units to compensate for hinge holes.



V-belt top pressure (optional)

Top pressure V-belt system optionally available instead of the standard top pressure roller system.

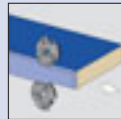

Rough trimming unit

For rough trimming of all common edge banding materials.

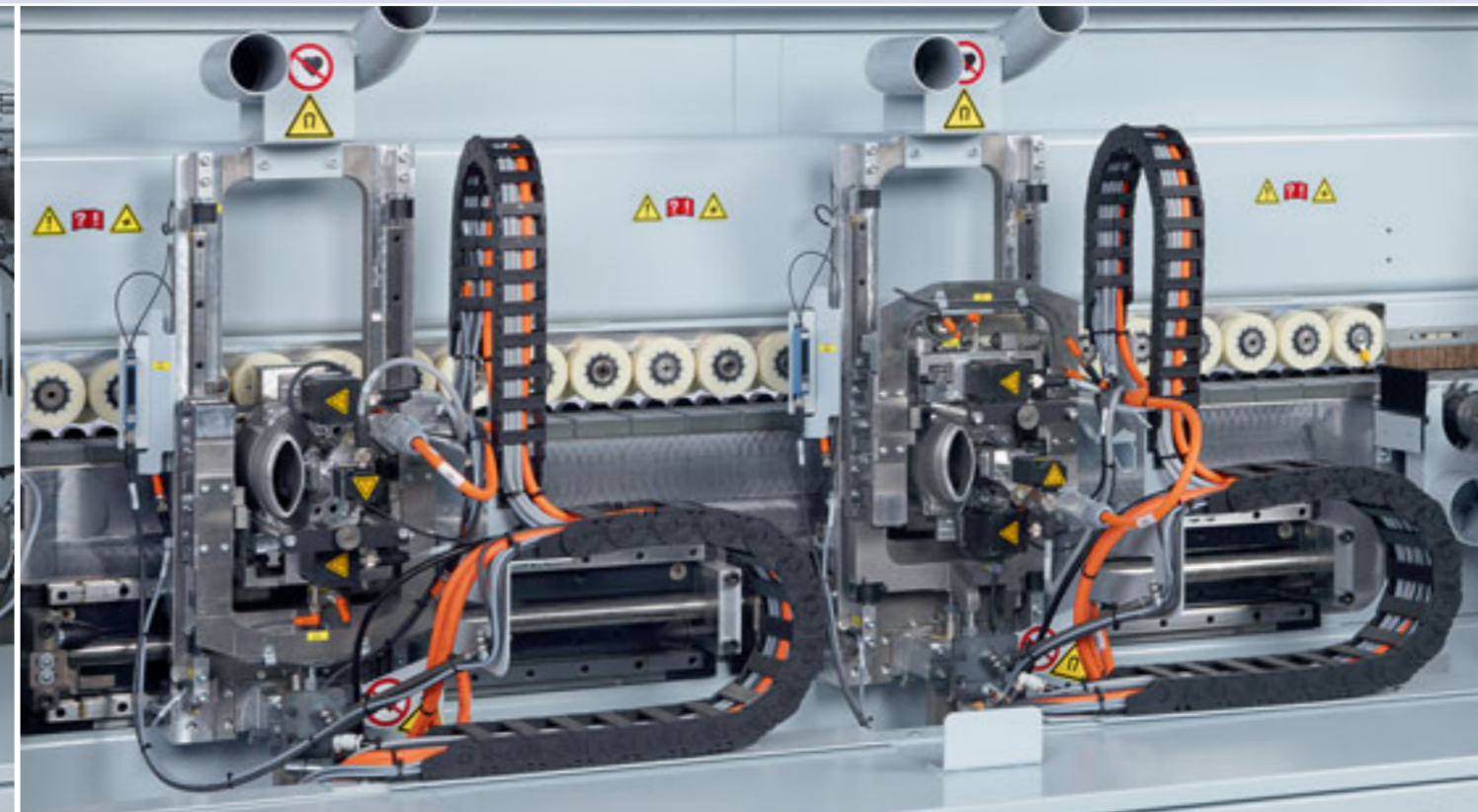
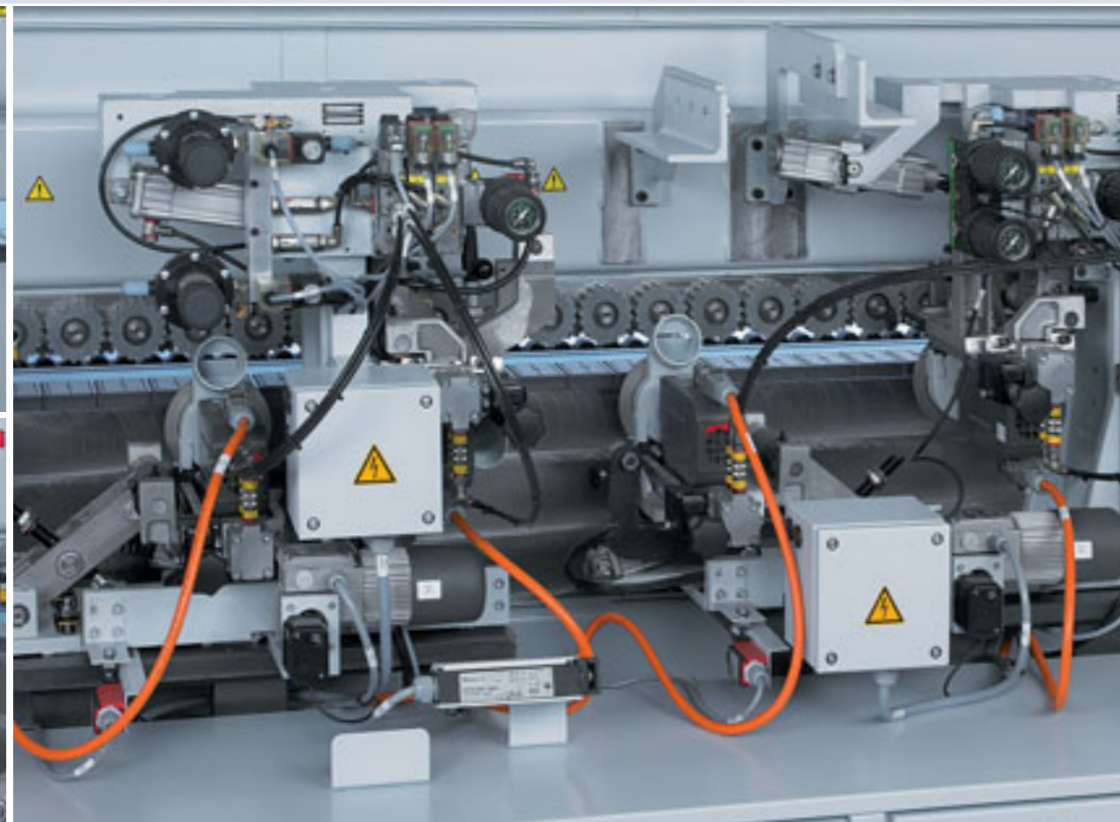
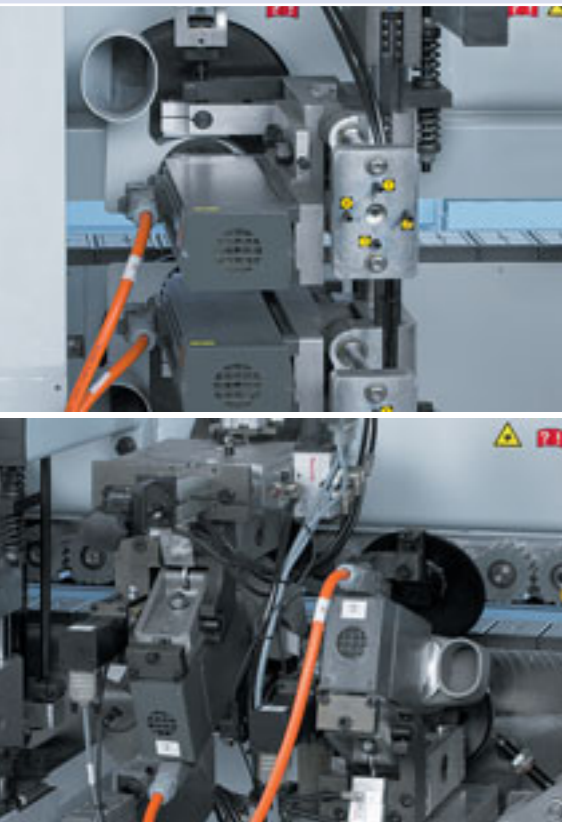

Trimming unit

Trimming unit with DFC tool technology for optimum extraction. Equipped with servo axis to adjust the unit automatically to edge thickness and profile.

Multistage trimming unit MS 40/45 (optional)

Fully automatic adjustment between 3 different profiles by means of servo motors.



Corner rounding unit FF12 (4 motors)

For corner rounding of thick PVC edges, as well as postforming and softforming profiles at feed speeds of up to 20 m/min. Equipped with servo motor adjustment for different edge thicknesses. Workpiece thickness up to 60 mm.



Multifunctional trimming unit MF 60 Servotrim

For processing the edging overhang at the upper and lower edge of the workpiece as well as for corner rounding of the front and rear edge. Servo-controlled movement with soft-touch function for optimal handling of e.g. high gloss surfaces or light weight panels. Workpiece thickness up to 100 mm.



Significant competitive advantages – Pace setting performance and quality. Highflex 1870 + 1880

Multistage technology



1. Straight 2. Profile 1 3. Profile 2

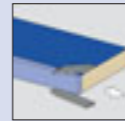

Glue joint scraping unit

For the perfect finish.

The new gluing generation – glue application as a system

Due to today's variety of products and increasing customer's demands it has become necessary to focus on a future-oriented gluing technique. The new glue application system QA 45 meets all market requirements and offers excellent solutions for a modern interior shop or furniture production companies.

Application unit QA 45 (optional)

- Special coating of the gluing unit for all types of glue, including PUR in order to meet all customers' requirements.
- Easy and fast change over of different types of glue through an automatic draining system, in order to make use of the ideal glue type or colour based on application.
- The automatic cleaning system is activated by the control, in order to minimize the downtime of the machine.
- Glue amount infinitely adjustable by servo motor in order to achieve a perfect result for most different workpiece materials.
- Glue application in both directions, synchronism and antirotation for a perfect adhesion of different edge materials.



Multistage trimming unit MS 40/45 (optional)

Fully automatic adjustment between 3 different profiles by means of servo motors.

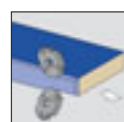

Multistage scraping unit MZ 40 (optional)

Fully automatic adjustment between 2 different profiles by means of servo motors.

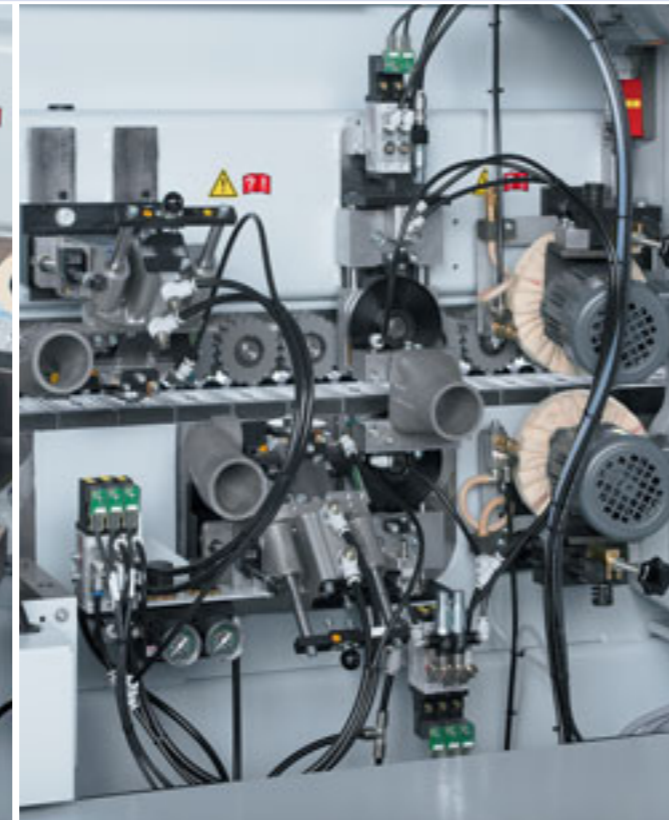
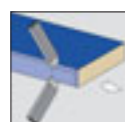

Profile scraping unit

Unit to smooth radii or chamfers, equipped with quick change heads for fast profile change.

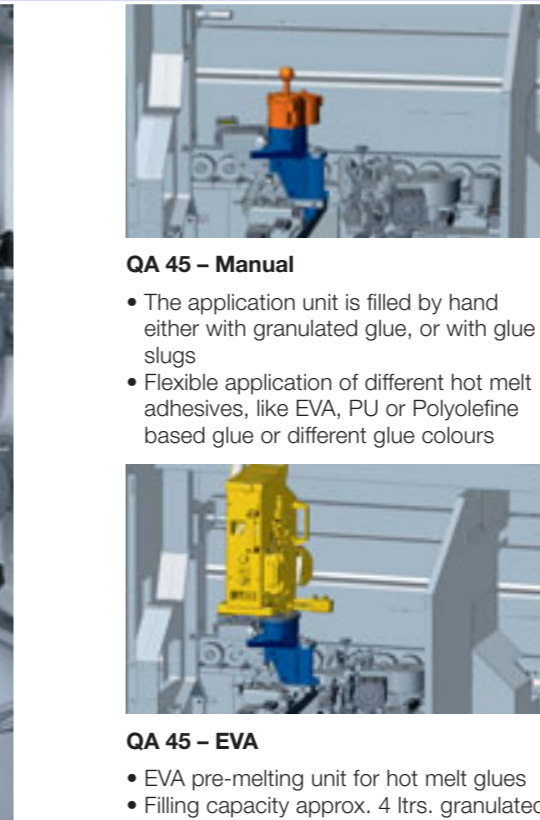
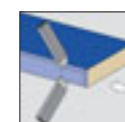

Buffing unit

Buffing unit to polish edges and maintain their natural colour.

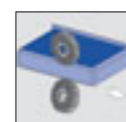

QA 45 – Manual

- The application unit is filled by hand either with granulated glue, or with glue slugs
- Flexible application of different hot melt adhesives, like EVA, PU or Polyolefine based glue or different glue colours

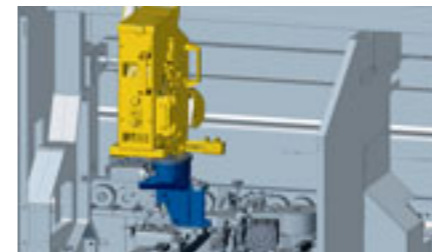

QA 45 – EVA

- EVA pre-melting unit for hot melt glues
- Filling capacity approx. 4 ltrs. granulated hot melt glue



QA 45 – PU

- PU pre-melting unit
- Chemcoat antioxidation coating of the glue melting container.
- Container size: 2 kg slugs



Technical data



Type of machine	Highflex 1220	Highflex 1230
Machine dimensions		
Machine length (mm)	4153	4773
Working height (mm)	950	
Machine dimensions WxH (mm)	1525 x 2182	
Working dimensions		
Workpiece thickness (mm)	8 - 60	
Edge material thickness (mm)	0,4 - 6	
Miscellaneous		
Feed speed (m/min)	11	
Weight (kg)	1290	1500
Connected value (kW)	9,8	
Extraction diameter (mm)	1x120/3x80/1x100	
Electrics	400 V - 3 Ph. - 50 Hz.	
Pneumatics (bar)	6	

Type of machine	Highflex 1430	Highflex 1440
Machine dimensions		
Machine length (mm)	4773	5273
Working height (mm)	950	
Machine dimensions WxH (mm)	1575 x 2182	
Working dimensions		
Workpiece thickness (mm)	8 - 60	
Edge material thickness (mm)	0,4 - 8	
Miscellaneous		
Feed speed (m/min)	var. 8 - 14	
Weight (kg)	1600	1850
Connected value (kW)	14,5	16
Extraction diameter (mm)	1x120/3x80/1x100	1x120/5x80/1x100
Electrics	400 V - 3 Ph. - 50 Hz.	
Pneumatics (bar)	6	

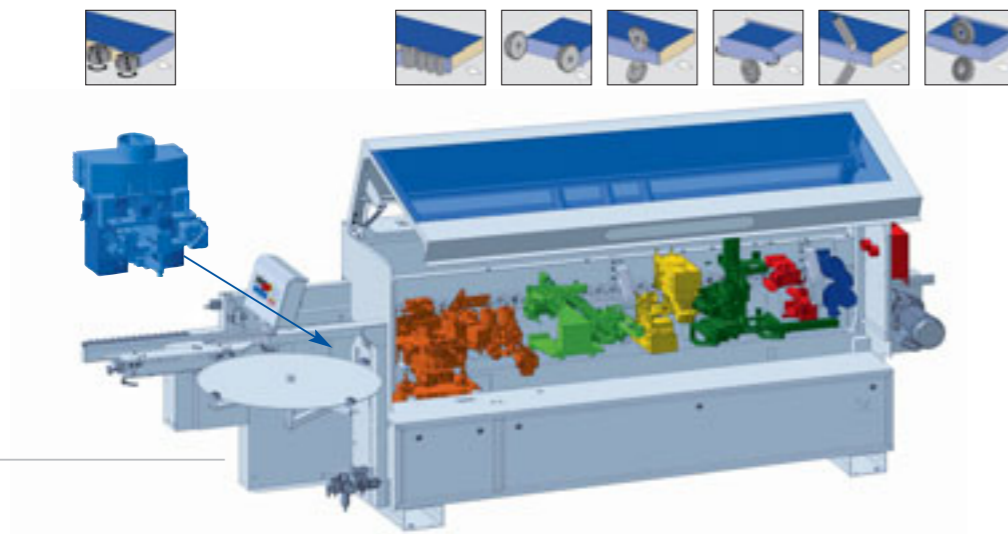

Highflex 1220

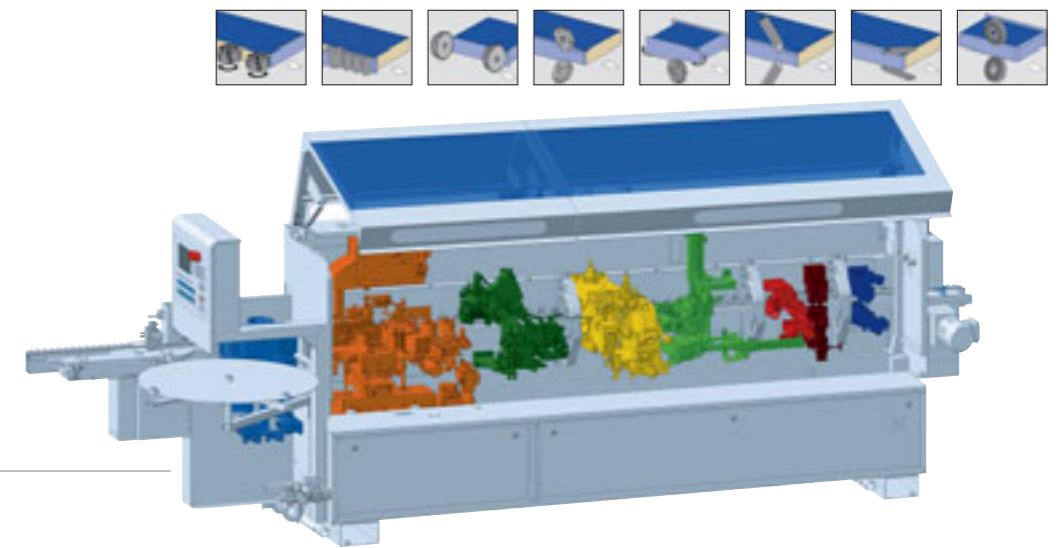

Highflex 1430

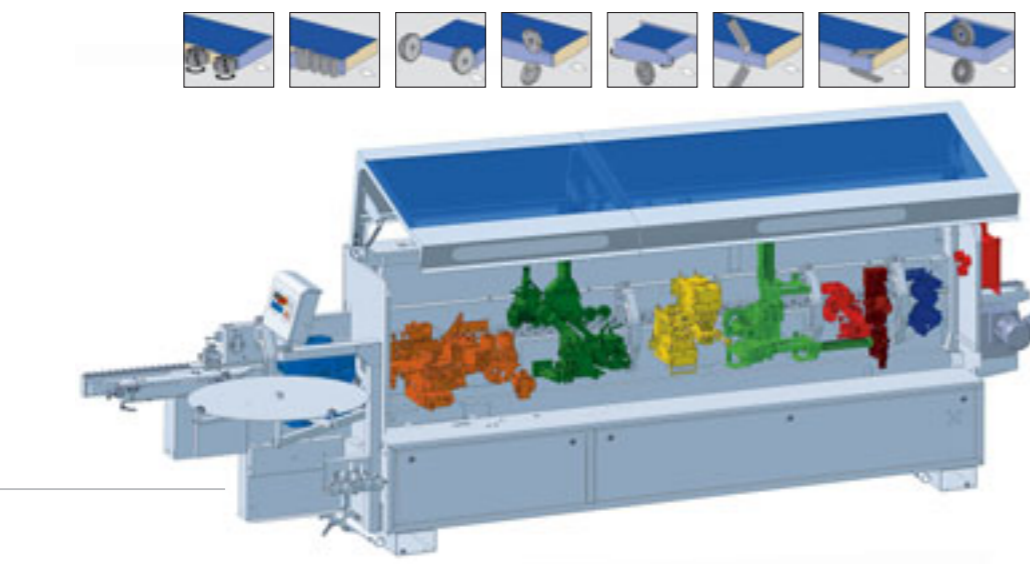

Highflex 1230

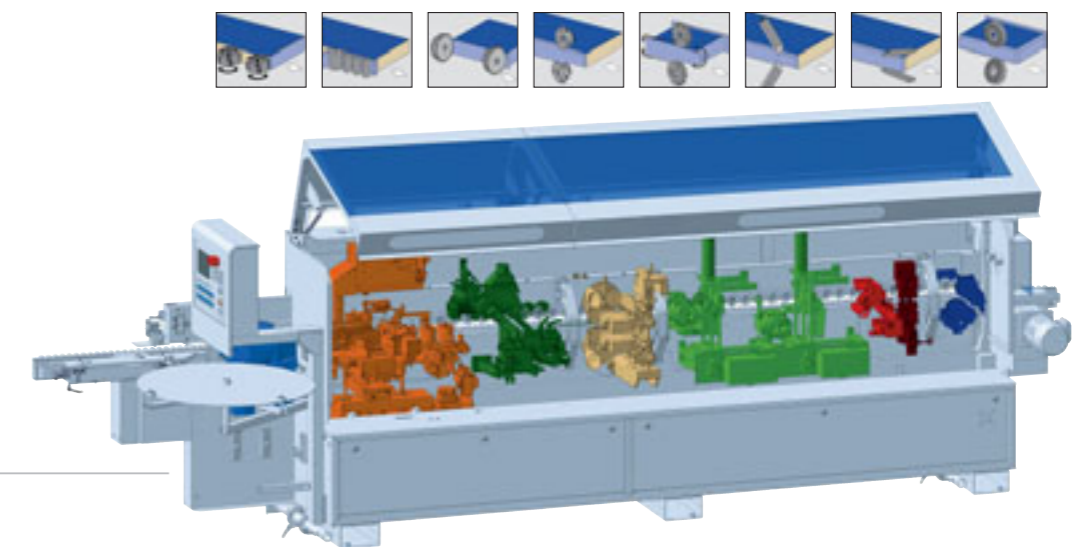

Highflex 1440

Technical data



Type of machine	Highflex 1650	Highflex 1660
Machine dimensions		
Machine length (mm)	5760	6260
Working height (mm)	950	
Machine dimensions WxH (mm)	1555 x 2300	
Working dimensions		
Workpiece thickness (mm)	8 - 60 (optional 80)	
Edge material thickness (mm)	0,4 - 15	
Miscellaneous		
Feed speed (m/min)	var. 8 - 18	
Weight (kg)	2600	3000
Connected value (kW)	23	24
Extraction diameter (mm)	1x120/1x160/1x100	1x120/1x200/1x100
Electrics	400 V - 3 Ph. - 50 Hz.	
Pneumatics (bar)	6	

Type of machine	Highflex 1870	Highflex 1880
Machine dimensions		
Machine length (mm)	6760	7260
Working height (mm)	950	
Machine dimensions WxH (mm)	1555 x 2300	
Working dimensions		
Workpiece thickness (mm)	8 - 60 (optional 80)	
Edge material thickness (mm)	0,4 - 15 (opt. 0,4 - 20)	
Miscellaneous		
Feed speed (m/min)	var. 8 - 20	
Weight (kg)	3400	3600
Connected value (kW)	26	25
Extraction diameter (mm)	1x120/1x160/1x100	1x120/1x200/1x100
Electrics	400 V - 3 Ph. - 50 Hz.	
Pneumatics (bar)	6	

All rights for technical changes withheld. Individual machine pictures may show options.

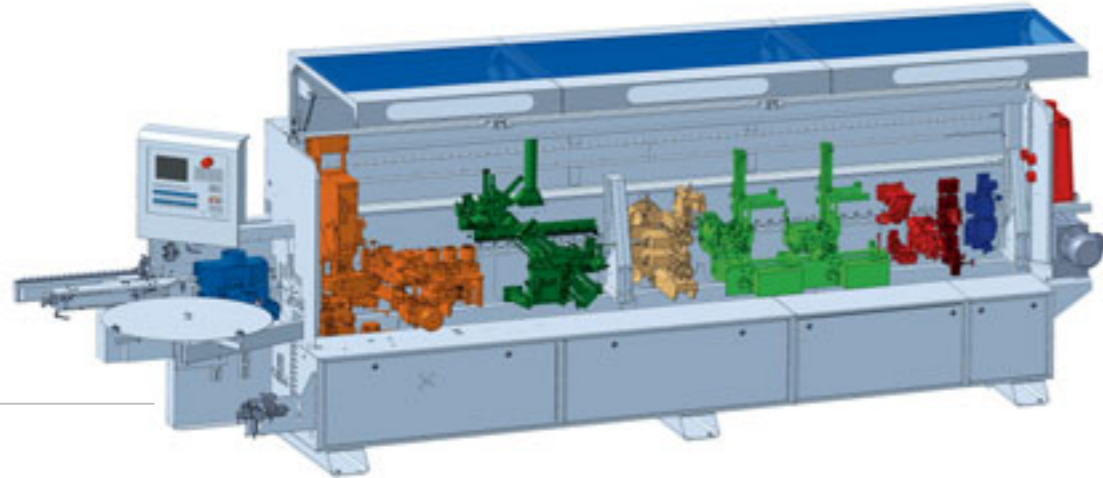
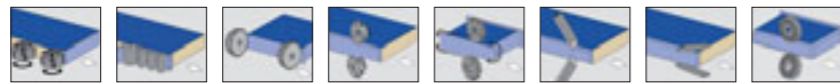

Highflex 1650

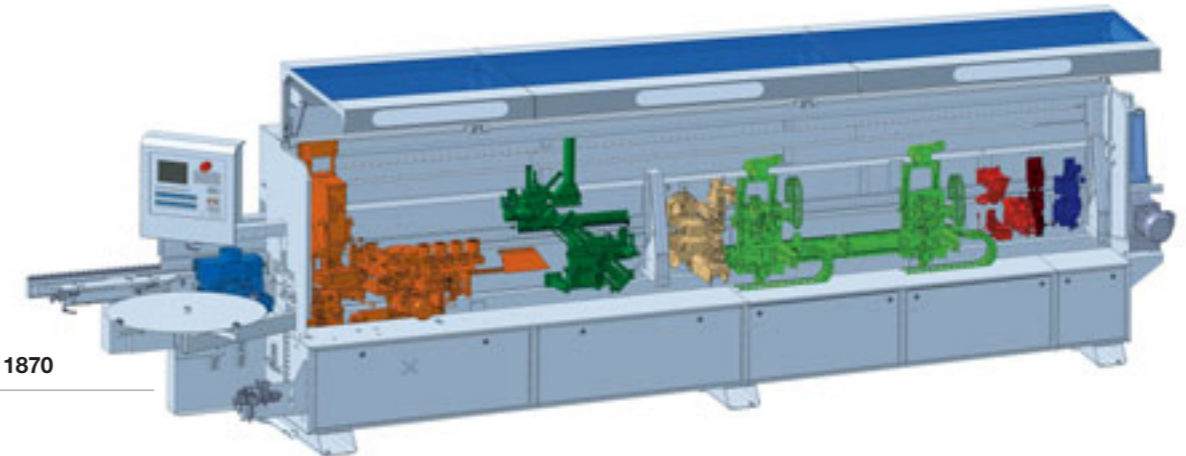
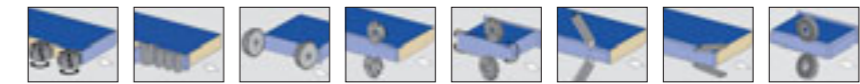

Highflex 1870

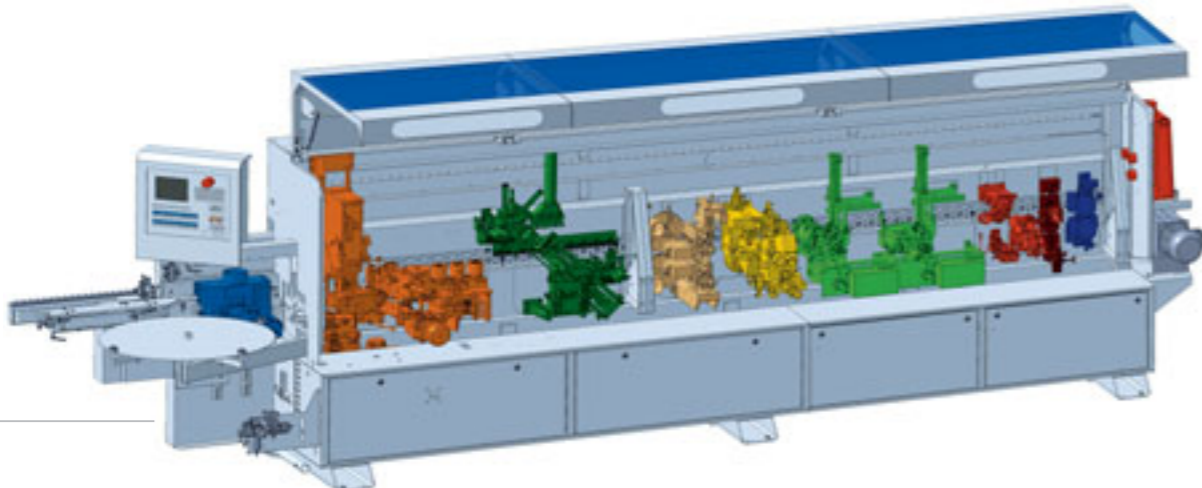

Highflex 1660

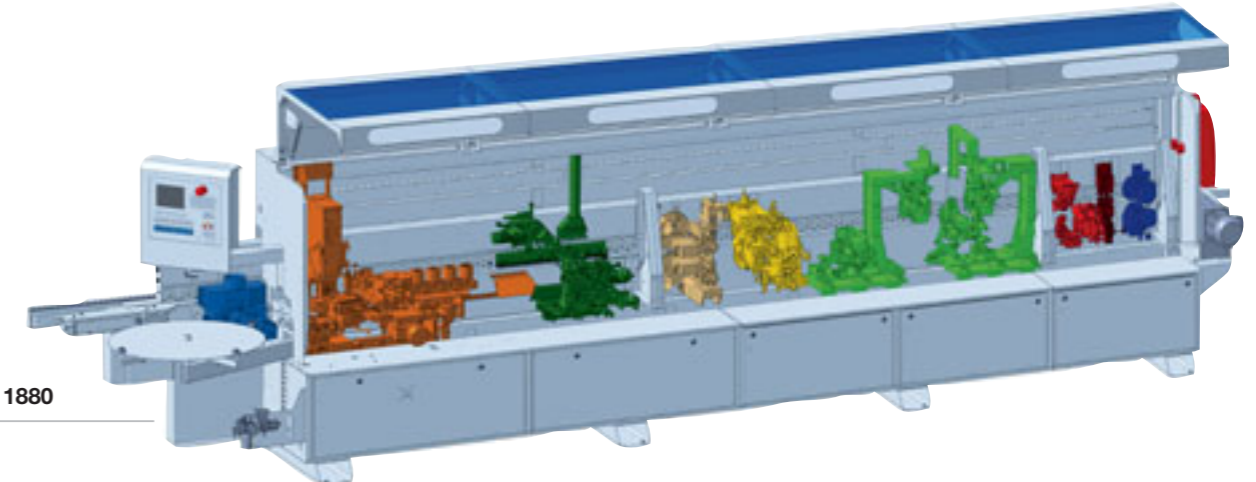

Highflex 1880

profiLine-series

Precision and performance for highest demands

Our profiLine series offer always the perfect solution for your needs. Its modular design and the freely-fittable frame concept allow it to fit perfectly to your production requirements.

Workpiece thicknesses of up to 100 mm can be processed, allowing you to keep up with current and future trends in the industry.

A universal trimming unit as well as a multi-stage trimming unit highlight the versatility of this machine series. The universal trimming unit offers high performance for grooving and profiling, and can be used in a very flexible manner. The multi-stage trimming unit is equipped

with servo-axis adjustments and allows for automatic changeover between four different profiles. A belt sanding unit with multiple pad capabilities is available for sanding of straight edges and radii.

Significant competitive advantages – Pace setting performance and quality. profiLine-series

„You define the task – we configure the right machine“

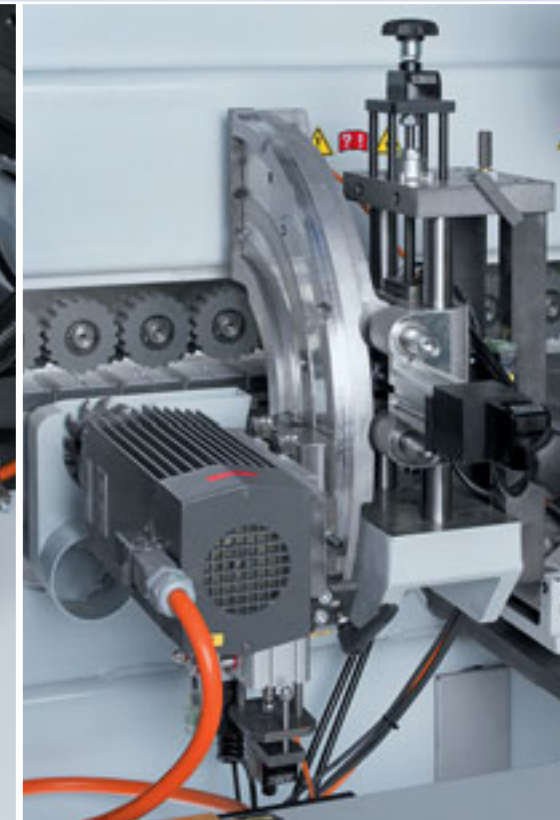
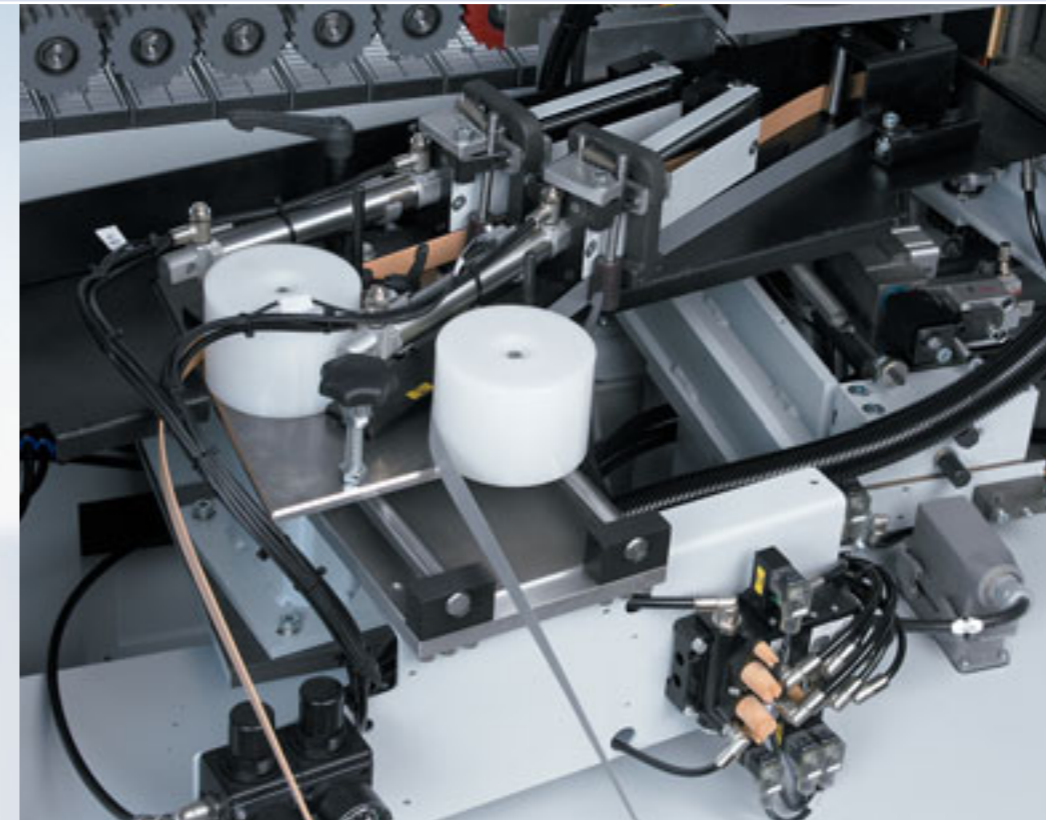

Automatic 2-coil magazine

Automatic 2-coil magazine for the highest possible flexibility and significant time savings during edge material changeovers.

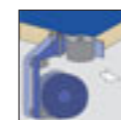

Tiltable grooving unit

For grooving work pieces either from the bottom side or from the edge side. It is possible to do either continuous grooving or non continuous grooving, as well as jump grooving for biscuit joints.



Significant competitive advantages – Pace setting performance and quality. profiLine-series

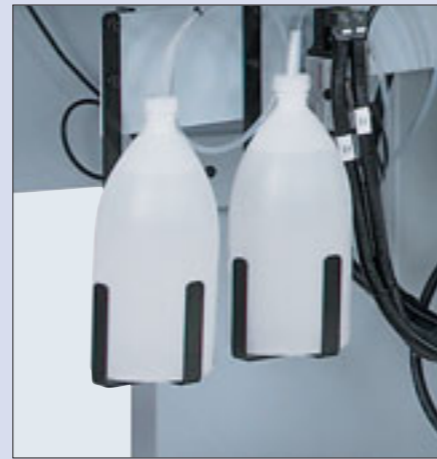

Spraying unit
Separation and detergent agents for a perfect finish when processing PU-glue.



V-belt top pressure (optional)
Top pressure V-belt system optionally available instead of the standard top pressure roller system.



Sanding unit
For sanding straight edges on different materials



Universal trimming unit
Universal unit with high capacity for grooving and profiling work. Flexible by unlimited setting options.

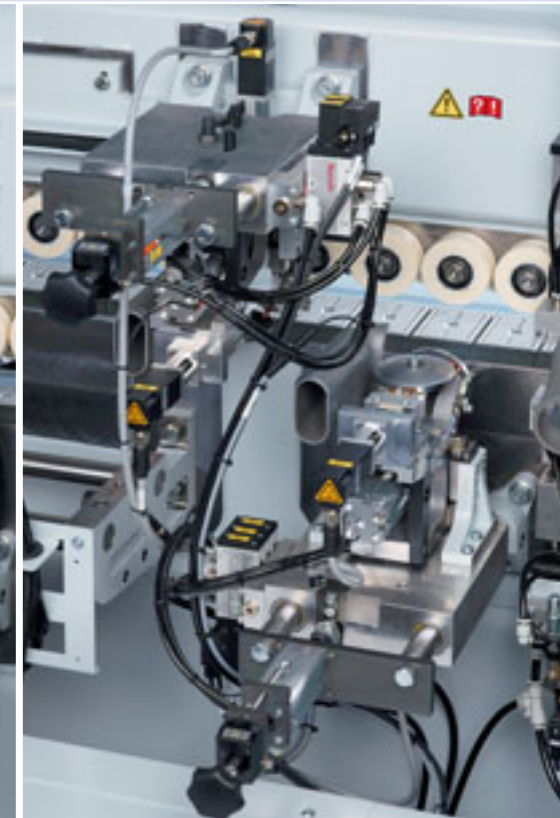
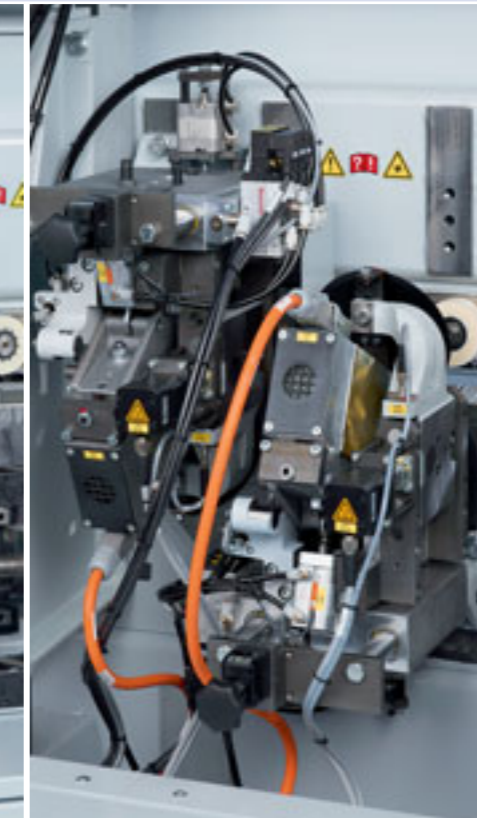
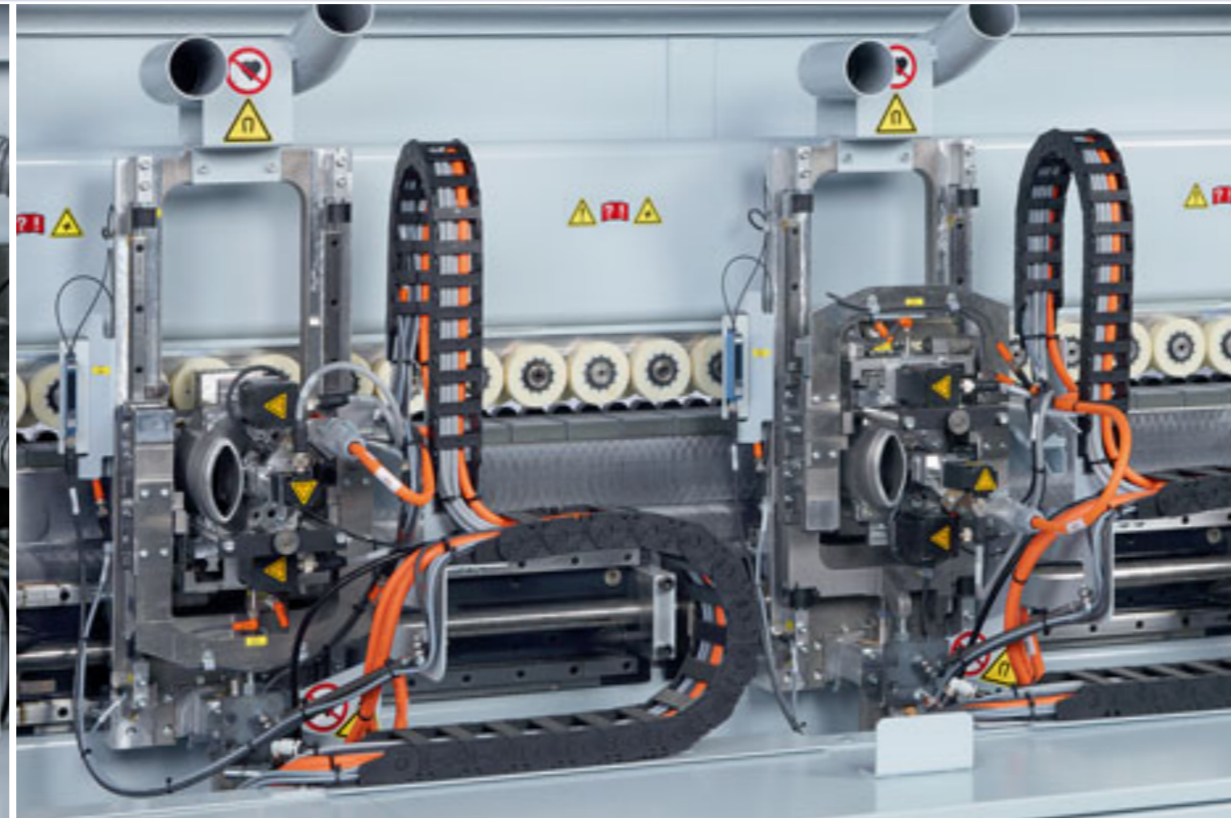
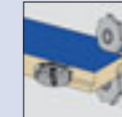

Multifunctional trimming unit MF 50
Trimming of the edge overhang on top and bottom side as well as contour trimming on the front and rear edges. Equipped with an automatic adjustment to switch between thick and thin edges. Workpiece thickness up to 60 mm.



Multifunctional trimming unit MF 60 Servotrim
For processing the edging overhang at the upper and lower edge of the workpiece as well as for corner rounding of the front and rear edge. Servo-controlled movement with soft-touch function for optimal handling of e.g. high gloss surfaces or light weight panels. Workpiece thickness up to 100 mm.



Multistage trimming unit MS 40/45
Fully automatic adjustment between 3 different profiles by means of servo motors.



Multistage scraping unit MZ 40
Fully automatic adjustment between 2 different profiles by means of servo motors.

