

JET MASTER

WORKING CENTER - BEARBEITUNGSZENTRUM - CENTRE D'USINAGE



JET MASTER

WORKING CENTER - BEARBEITUNGZENTRUM - CENTRE D'USINAGE

The new JET MASTER series unites the customary high quality of Busellato's machines with high performance and great working flexibility. The wide range of solutions available makes the JET MASTER series ideal for any type of application. The name MASTER recalls an historic BUSELLATO working center manufactured at the beginning of the 1970's.

Die neue Serie JET MASTER ergänzt zu der üblichen Busellato Qualität hohe Leistungsfähigkeit und große Bearbeitungsflexibilität. Die umfangreichen Lösungen für diese Maschine machen aus der Serie JET MASTER die ideale Maschine für jeden Bedarf. Der Name MASTER wird von einem BUSELLATO Bearbeitungszentrum aufgenommen, das bereits Anfangs der 70iger Jahre produziert wurde.

La nouvelle série JET MASTER joint à la qualité habituelle Busellato haute performance et grande flexibilité d'usinage. La gamme des solutions disponibles rend la série JET MASTER idéale pour tous type d'usinage. Le nom MASTER est le nom d'une centre d'usinage Busellato historique qui à été produit au début des 70 ans.



Machining windows
Bearbeitungsbeispiele von Fensterproduktion
Usinage de fenêtres



Machining doors
Türenbearbeitung
Usinage de porte



JET MASTER

WORKING CENTER - BEARBEITUNGSZENTRUM - CENTRE D'USINAGE



Machining stair parts
Treppenbearbeitung
Usinage d'escalier



Machining furniture parts
Möbelemente
Usinage de composant de meubles



JET MASTER

MACHININGS - BEARBEITUNGEN - USINAGES

JET MASTER offers a whole range of solutions for all machinings on solid wood parts and furniture parts.

JET MASTER bietet eine komplette Reihe von Lösungen an für die Bearbeitung von Massivelemente und Möbelteile.

JET MASTER offre une gamme des solutions complètes pour l'usinage des pièces en bois massif et composants de meubles.



Machining windows
Bearbeitungsbeispiele von Fensterproduktion
Usinage de fenêtres

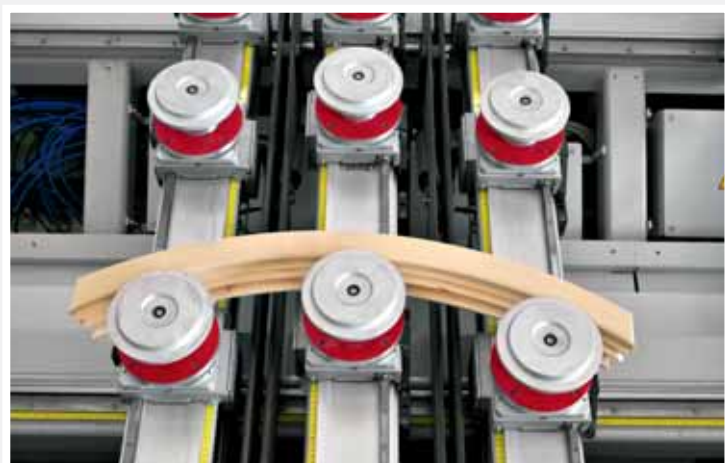

JET MASTER

MACHININGS - BEARBEITUNGEN - USINAGES



Machining doors
Türenbearbeitung
Usinage des portes

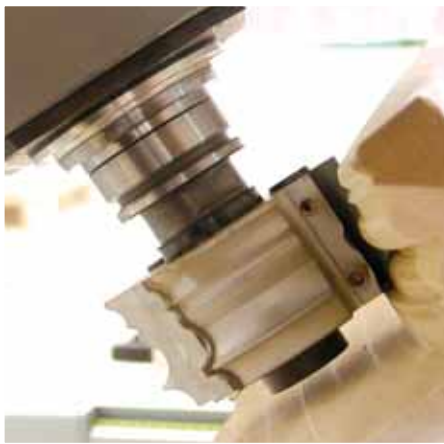

Machining stair parts
Treppen
Usinage des escaliers

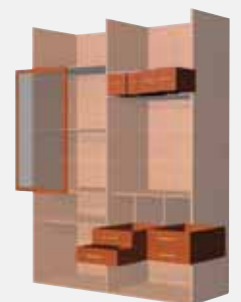

Machining furniture parts
Möbelemente
Usinage composants de meubles

JET MASTER

PANEL SUPPORTS - KONSOLENTISCHE - PLANS D'APPUI

The IMC panel supports allow the work bed configuration to be changed according to the machinings required. The moveable supports applied to the panel support, complete with vacuum and compressed air circuits for management of all devices applied, guarantee precision and a long life. The wide range of accessories available allow machinings using either vacuum cups or clamping systems for narrow or thick parts.

Das Bearbeitungszentrum JET OPTIMA P und S sind mit TL (schlauchlos) und IMC Tische ausgestattet, die eine Änderung der Konfiguration des Arbeitstisches je nach Bearbeitung ermöglichen. Die große Anzahl von Zubehör ermöglicht weiterhin auch Bearbeitungen mit Klemmsysteme.

Les centres d'usinages JET OPTIMA P et S sont équipés avec plans d'appui TL (tubeless) et IMC qui permet de modifier la configuration du plan d'appui selon les usinages. La grande gamme d'accessoires permet également de travailler avec des systèmes de verrouillage.



Examples of IMC vacuum cups
Beispiele von IMC Sauger
Exemple de ventouses IMC



Vertical clamps with magnetic coupling and horizontal clamps
Vertikale Klemme mit magnetischer Kupplung und horizontale Klemmen
Verrouillages verticaux avec attelage magnétique et verrouillages horizontaux

JET MASTER

PANEL SUPPORTS - KONSOLENTISCHE - PLANS D'APPUI

The controlled axes positioning system allows the work bed to be configured quickly and automatically without intervention by the operator.

Das Positionierungssystem mittels gesteuerte Achsen ermöglicht eine schnelle Konfiguration des Arbeitstisches, vollkommen automatisch und ohne Eingriff des Bedienungsmanes.

Le système de positionnement avec axes contrôlés permet une configuration rapide du plan d'appui en automatique et sans intervention du opérateur.

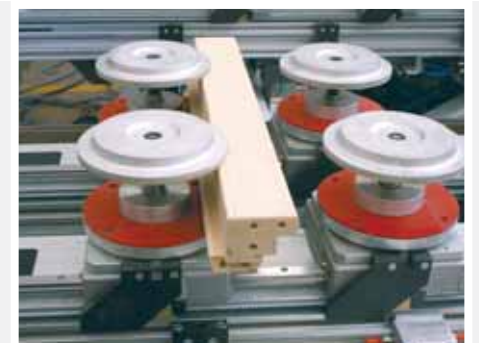

Automatic machining changeover
Automatischer Bearbeitungswechsel
Changement d'usinage automatique



Automatic positioning from NC with head mounted device
Automatische NC-Positionierung mit Vorrichtung an Arbeitsaggregat montiert
Positionnement automatique par contrôle numérique avec dispositif sur la tête

JET MASTER RT

WORK BED - KONSOLENTISCHE - PLANS D'APPUI

The Jet MASTER RT is equipped with a router table with reticular grid which allows machinings using vacuum cups or Nesting.

Jet optima RT ist mit ein Rastertisch ausgerüstet, welcher eine Bearbeitung mit Vakuumeinheit ermöglicht oder in Nesting-Ausführung.

JET OPTIMA RT est équipée d'un plan quadrillé permettant l'usinage avec modules à vide ou pour l'imbrication.

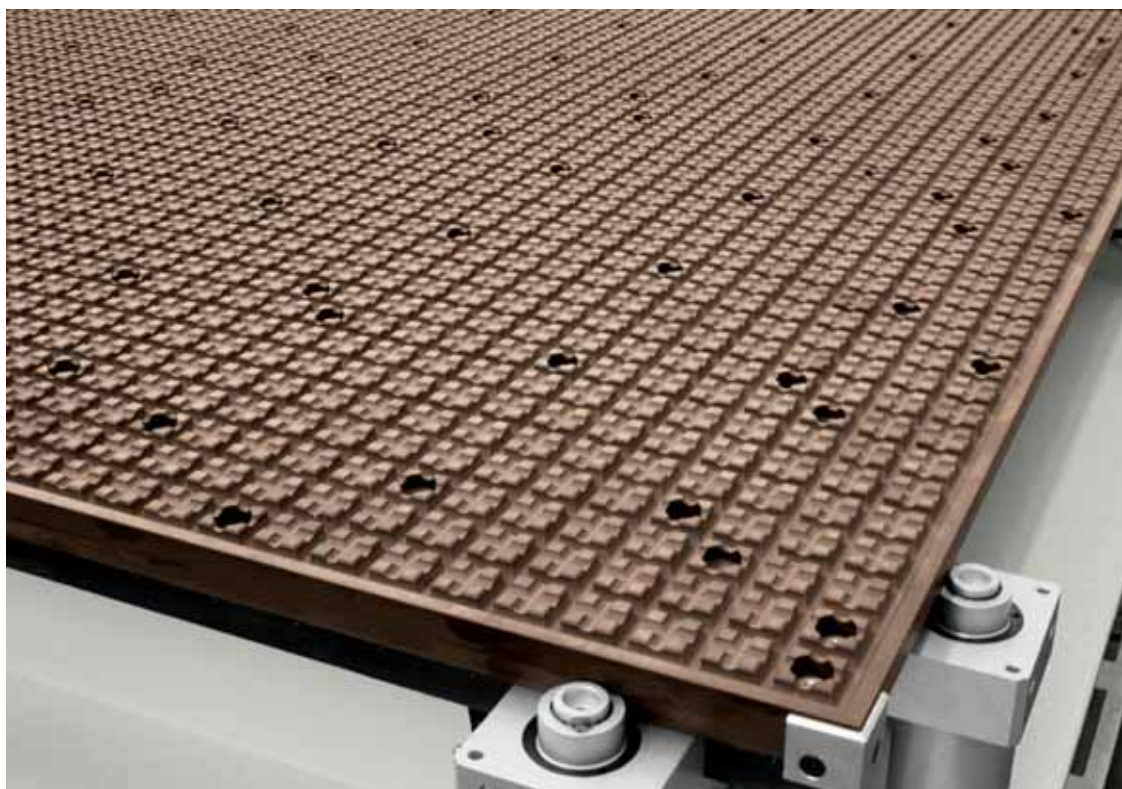

Router Type

Table phenolic based synthetic fibre working table, reticular grid 30x30 mm

Tisch RT

Arbeitstisch mit Basis aus Phenolharz mit Raster 30 x 30

Plan RT

Plan d'appui à base de résine phénolique avec quadrillé 30 x 30



WORK BED - KONSOLENTISCHE - PLANS D'APPUI

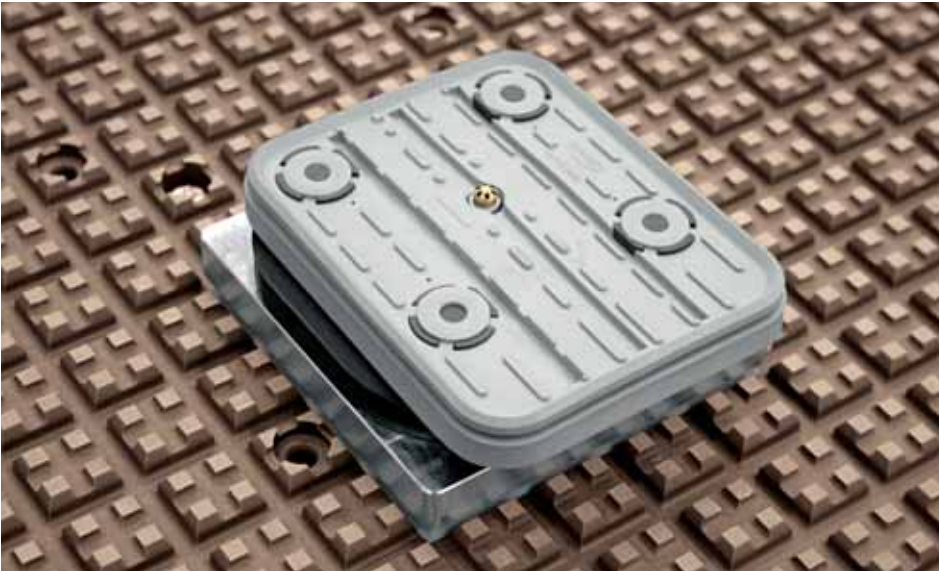

Swivelling modular vacuum cups for router type table.

Modulare, schwenkbare Sauger für Rastertisch.
Ventouses modulaires orientables pour plan quadrillé.

The plugs allow the targeted use of the vacuum.
Die Stöpsel ermöglichen eine gezielte Nutzung des Vakuums.
Les bouchons permettent l'utilisation ciblée du vide.



JET MASTER

WORKING UNITS - ARBEITSEINHEITEN - UNITÉS D'USINAGE



			TFM18	TFM23	26M	TFM32	TFM37	
X axis vertical spindles	Vertikale Bohrspindeln in X-Achse	Broches verticales axe X	Nr	7	13	10	20	18
Y axis vertical spindles	Vertikale Bohrspindeln in Y-Achse	Broches verticales axe Y	Nr	5	10	8	12	9
X axis horizontal spindles	Horizontale Bohrspindeln in X-Achse	Broches horizontales axe Y	Nr	2 + 2	-	2+2	-	3 + 3
Y axis horizontal spindles	Horizontale Bohrspindeln in Y-Achse	Broches horizontales axe X	Nr.	1 + 1	-	2+2	-	2 + 2
Integrated saw	Integrierte Säge	Lame intégrée	Ø	120	120	120	120	120
Motor power	Motorleistung	Puissance moteur	Kw	1,7	1,7	2,2	3	3,6

JET MASTER

TOOL CHANGERS - WERKZEUGLAGER - MAGASINS OUTIL



16/24-position rear rotary tool changer
Hinteres Werkzeuglager mit 16/24 Positionen
Magasin rotatif arrière à 16/24 positions



Double lateral tool position
Doppelseitige Werkzeugposition
Double position outil latérale



ST 12 tool changer
Drehendes Werkzeuglager BT
Magasin rotatif BT (sur tête)

JET MASTER 20

WORKING AREAS – ARBEITSBEREICHE - CHAMPS DE TRAVAIL

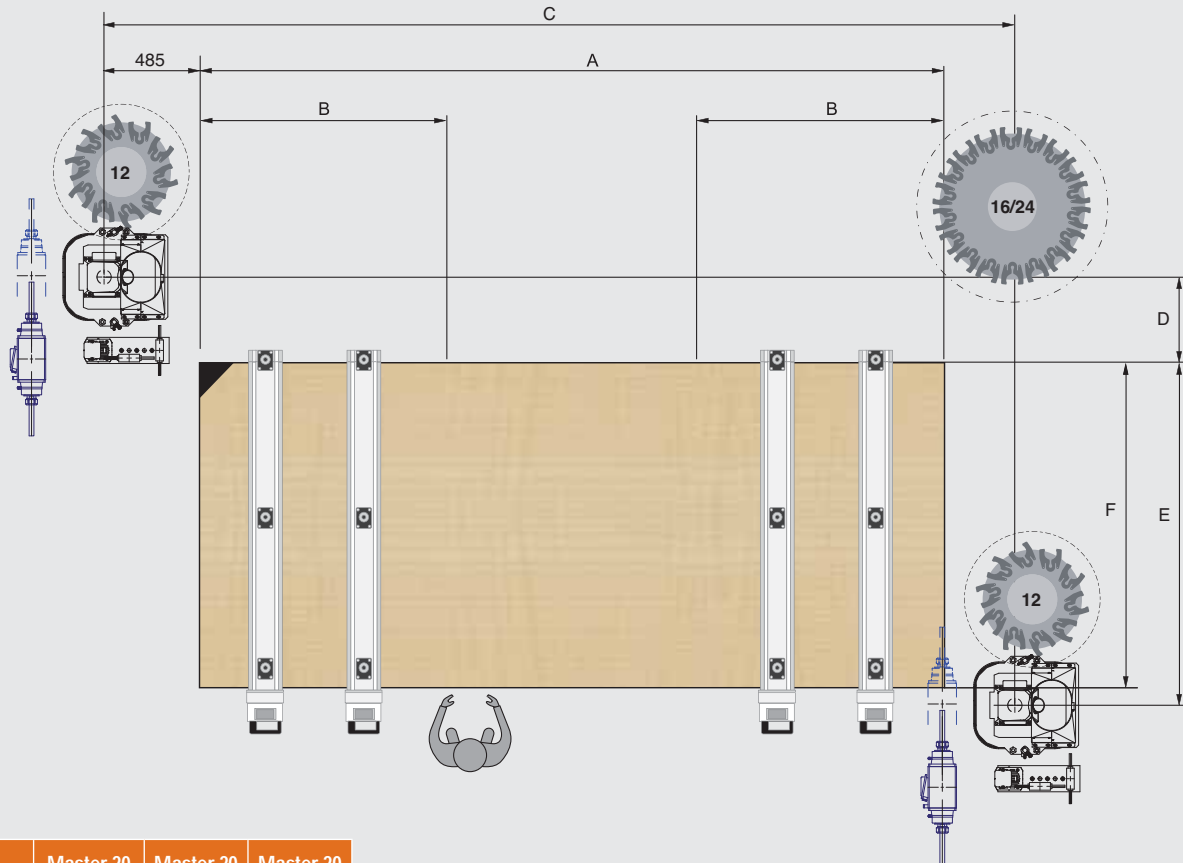

		Master 20 WF	Master 20 WF XL	Master 20 WF XXL
A	mm	3300	4800	6700
B	mm	1200	1800	2700
C	mm	4360	5800	7723
D	mm	350	350	350
E	mm	1570	1570	1570
F	mm	1550	1550	1550

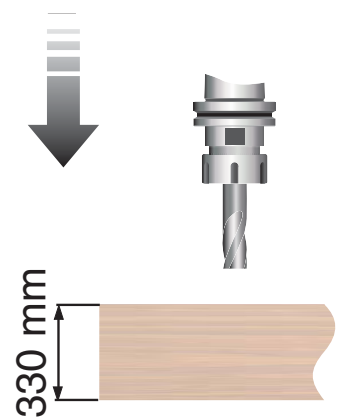
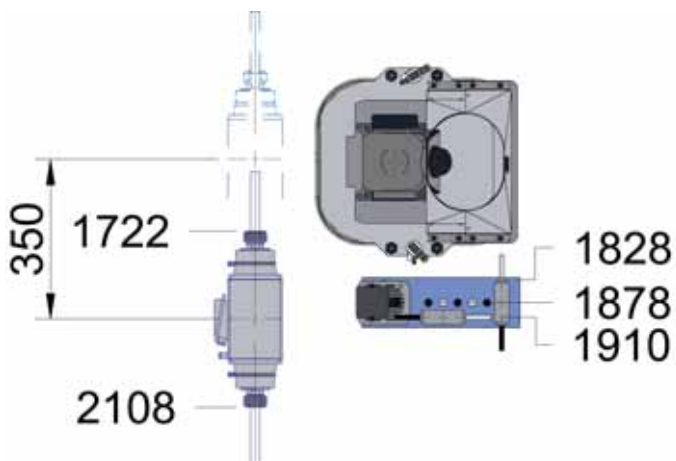

JET MASTER 20 RT

WORKING AREAS – ARBEITSBEREICHE - CHAMPS DE TRAVAIL

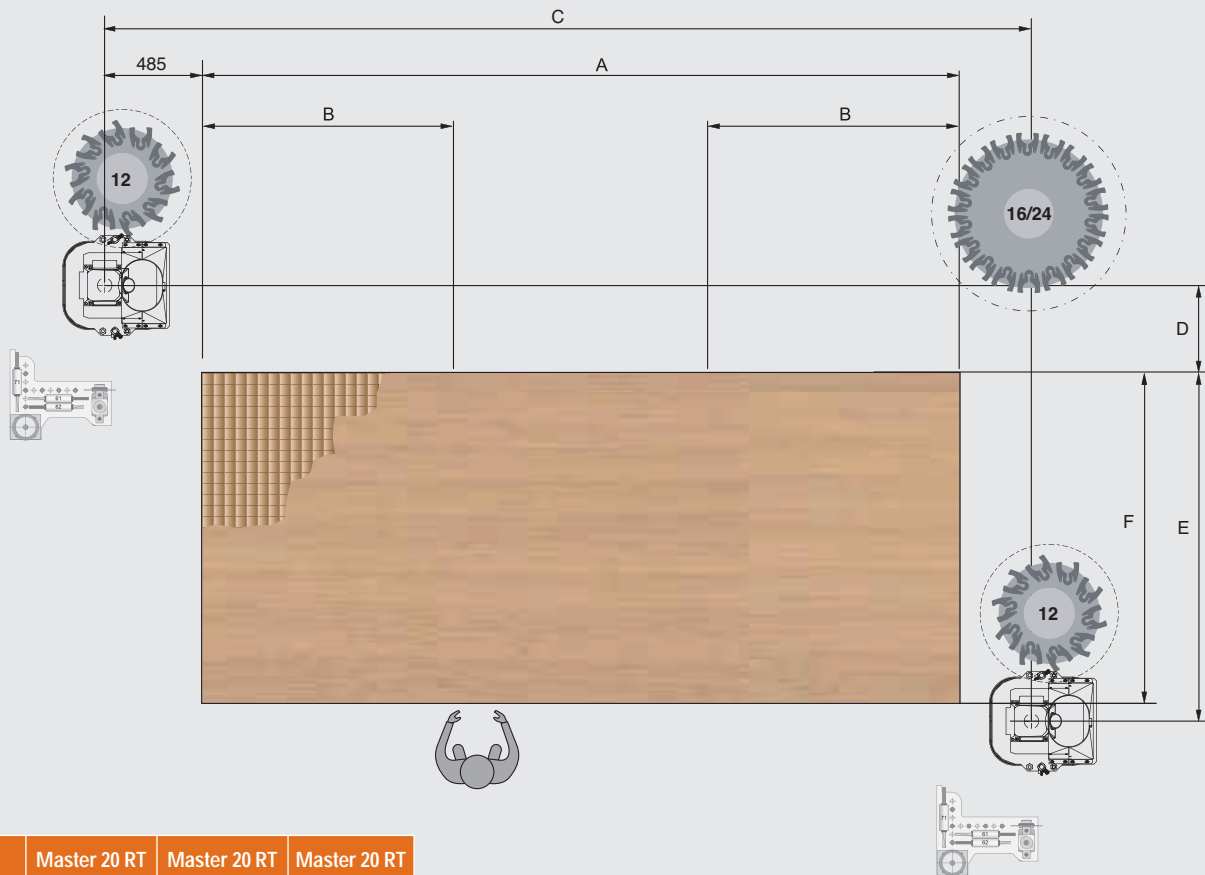

		Master 20 RT WF	Master 20 RT WF XL	Master 20 RT WF XXL
A	mm	3296	4796	6716
B	mm	1200	1800	2700
C	mm	4360	5800	7723
D	mm	350	350	350
E	mm	1570	1570	1570
F	mm	1556	1556	1550

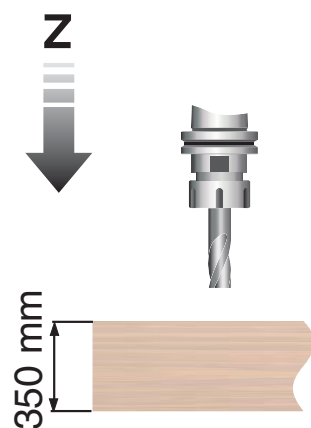

JET MASTER 25

WORKING AREAS – ARBEITSBEREICHE - CHAMPS DE TRAVAIL

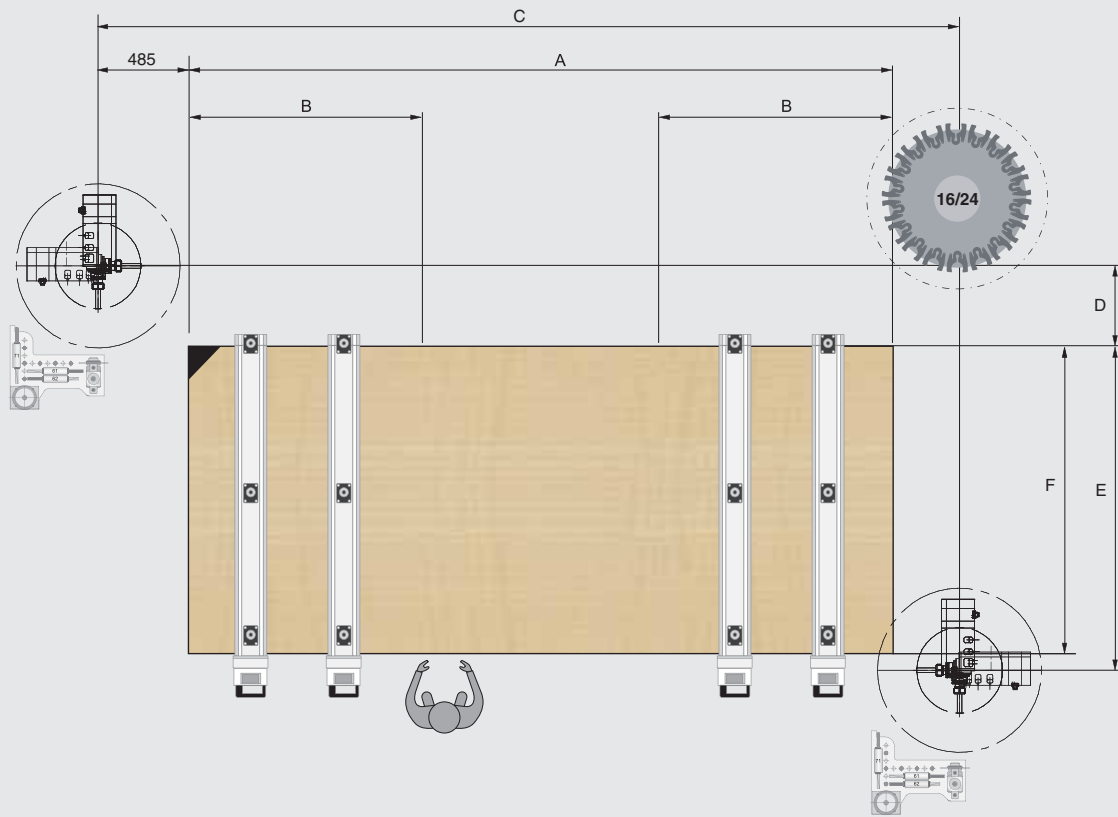

		Master 25 WF	Master 25 WF XL	Master 25 WF XXL
A	mm	3300	4800	6700
B	mm	1200	1800	2700
C	mm	4360	5800	7723
D	mm	350	350	350
E	mm	1570	1570	1570
F	mm	1550	1550	1550

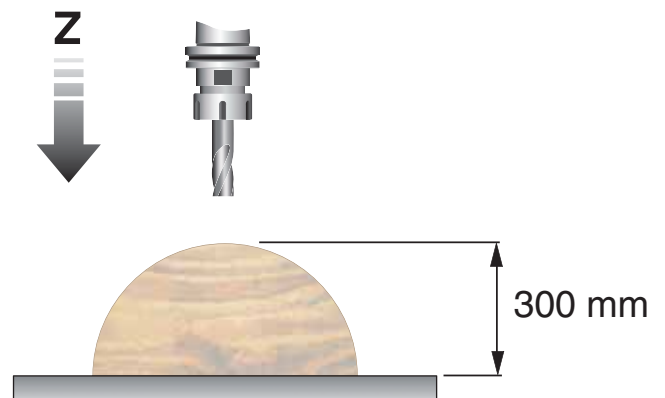

JET MASTER 25 RT

WORKING AREAS – ARBEITSBEREICHE - CHAMPS DE TRAVAIL

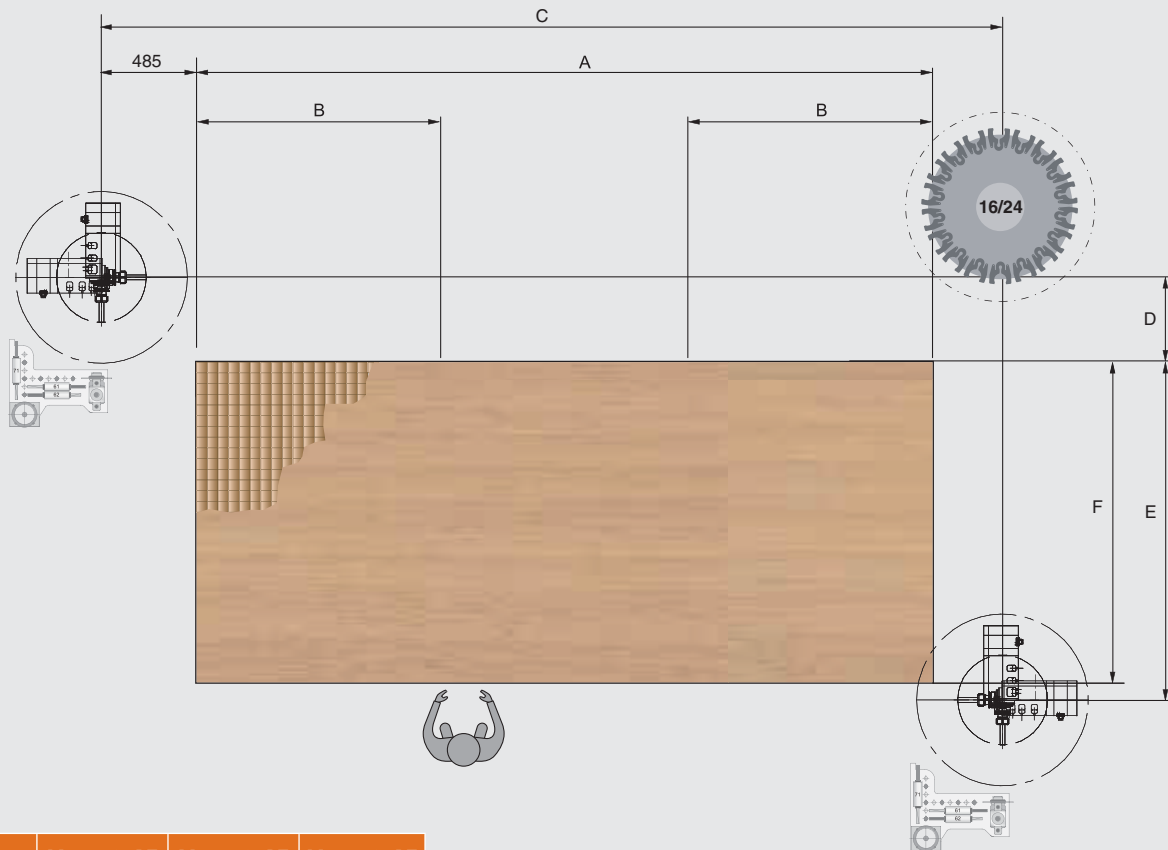

		Master 25 RT WF	Master 25 RT WF XL	Master 25 RT WF XXL
A	mm	3296	4796	6716
B	mm	1200	1800	2700
C	mm	4360	5800	7723
D	mm	350	350	350
E	mm	1570	1570	1570
F	mm	1556	1556	1556

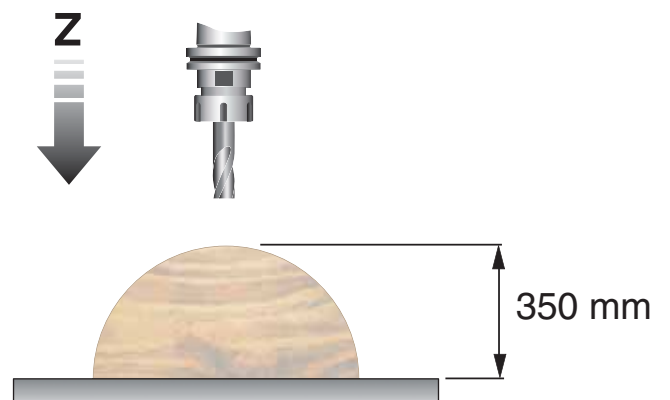

JET MASTER

CONFIGURATIONS – KONFIGURATIONEN - CONFIGURATIONS



			CONF . 1		CONF . 2		CONF . 3		CONF . 4		CONF . 5	
			Z1	Z2	Z1	Z2	Z1	Z2	Z1	Z2	Z1	Z2
E/S	E/S	E / M		✘		✘		✘	✘	✘		
5 axes	5 Achsen	5 Axes										✘
TFS9	TFS9	TFS9			■						■	
TFM18	TFM18	TFM18	■								■	
26M	26M	26M	■									
TFM32	TFM32	TFM32					■					
TFM37	TFM37	TFM37					■					
1-OUTLET ROUTER	FRÄSER 1 AUSGANG	UNITÉ DE DEFONCAGE 1 SORTIE	▲									
2-OUTLET ROUTER	FRÄSER 2 AUSGANGE	UNITÉ DE DEFONCAGE 2 SORTIE			▲							
VERTICAL ROUTER	VERTIKALER FRÄSER	UNITÉ DE DEFONCAGE VERTICALE	▲									
TILTING ROUTER	SCHWENKBAR	INCLINABLE			▲							
SAW/ROUTER	SÄGE/FRÄSER	LAME/FRAISE	▲									
BT12	BT12	BT12		●		●		●		●		●
16-POSITION REAR TOOL CHANGER	WERKZEUGLAGER 16 POSITIONEN	MAGASIN OUTILS 16 POSITIONS		◆		◆		◆		◆		◆
24-POSITION REAR TOOL CHANGER	WERKZEUGLAGER 24 POSITIONEN	MAGASIN OUTILS 24 POSITIONS		◆		◆		◆		◆		◆

✘ ■ ▲ ● ◆ = Max. 1 symbol in column Z1
 ✘ ■ ▲ ● ◆ = Max. 1 symbol in column Z2

✘ ■ ▲ ● ◆ = Max. nr. 1 Symbol je Ständer Z1
 ✘ ■ ▲ ● ◆ = Max. nr. 1 Symbol je Ständer Z2

✘ ■ ▲ ● ◆ = Max. 1 Symbole par colonne Z1
 ✘ ■ ▲ ● ◆ = Max. 1 Symbole par colonne Z2

JET MASTER

AGGREGATES - BEARBEITUNGSKOPF - TÊTE D'USINAGE



1 outlet saw/router aggregate - 180 mm \varnothing blade
 Aggregat Fräse/Säge 1 Ausgang - Sägedurchmesser 180 mm.
 Tête fraise/lame à 1 sortie - diamètre lame 180 mm.



Aggregate with 4 horizontal outlets
 Aggregat mit 4 horizontale Ausgänge
 Tête avec 4 sorties horizontales



Aggregate for underside machining
 Aggregat für Bearbeitungen unten
 Tête pour usinages inférieurs



Saw/router aggregate with 2 horizontal outlets - 140 mm \varnothing blade
 Aggregat Fräse/Säge 2 horizontale Ausgänge - Sägedurchmesser 140 mm.
 Tête fraise/lame à 2 sorties horizontales - lame \varnothing 140 mm.



Saw/router aggregate with 2 horizontal outlets - 220 mm \varnothing blade
 Aggregat Fräse/Säge 2 horizontale Ausgänge - Sägedurchmesser 220 mm.
 Tête fraise/lame à 2 sorties horizontales - lame \varnothing 220 mm.

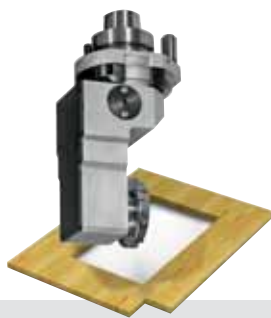

Notching aggregate - \varnothing max. 70 mm
 Aggregat für Notching - \varnothing max. 70 mm
 Tête pour coupe verticale - \varnothing max. 70 mm



Aggregate for horizontal machinings - 130 mm length tool
 Aggregat für horizontale Bearbeitungen - Fräser L = 130 mm
 Tête pour usinages horizontaux - fraise L= 130 mm.



Counterbalanced aggregate - max. \varnothing 100 mm
 Aggregat zum Planfräsen - \varnothing max. 100 mm.
 Tête pour fraisage supérieur - \varnothing max. 100 mm.

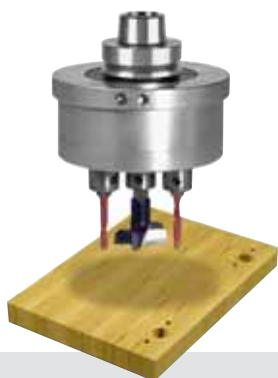

Aggregate for hinges, 48-6 pitch
 Aggregat für Scharniere Achsenabstand 48-6
 Tête pour charnière montée entraxe 48-6



Saw aggregate max. \varnothing 250 mm
 Nutsägeaggregat \varnothing max. 250 mm
 Tête lame \varnothing max. 250 mm



Saw aggregate max. \varnothing 300 mm
 Nutsägeaggregat \varnothing max. 300 mm
 Tête lame \varnothing max. 300 mm



Drilling aggregate with 2 horizontal outlets
 Bohrwinkelkopf mit 2 horizontalen Ausgängen
 Tête de perçage à 2 sorties horizontales

JET MASTER

DEVICES - VORRICHTUNGEN - DISPOSITIFS



Partialized dust extraction collector
Unterteilter Absaugungsförderer
Convoyeur d'aspiration partagé



JET MASTER RT:
Tool length presetting device
Voreinstellungsvorrichtung Werkzeuglänge
Dispositif de pré-étalonnage de la longueur de l'outil



Air conditioning system for the electrical cabinet
Kühlung für elektrischen Schaltschrank
Climatiseur pour armoire électrique



Turn your CNC working center into a 4/5 axis machine thanks to "QinX", a saw/router unit with NC-controlled variable inclination.

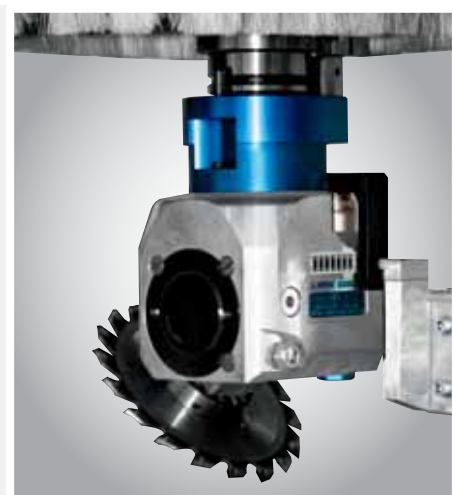

Ändern Sie Ihr Bearbeitungszentrum in eine 4/5-Achsenmaschine um dank "QinX", ein Säge/ Fräse Aggregat mit NC-gesteuerter Neigung.

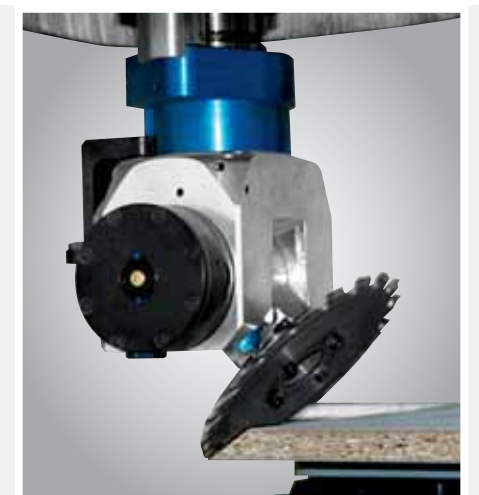

Transforme ton centre d'usinage en machine à 4/5 axes grâce à "Qin_X", agrégat lame/fraise à inclinaison variable gérée par CN.

JET MASTER

DEVICES - VORRICHTUNGEN - DISPOSITIFS



Luminous indicators to regulate access to the loading/unloading area
Leuchtmelder für Freigabe Zugang im Aufgabe-/Abladebereich
Indicateurs lumineux pour régulariser l'accès à la zone de chargement/déchargement



Chip guard device on electrospindle
NC-gesteuertes Späneabweisblech auf Elektroschindel
Dispositif avec déflecteur de copeaux orientable sur électrobroche



Remote push-button panel
Bewegliche Bedienertafel
Pupitre de commande à distance



Belt conveyor for chip evacuation
Spänetransportband
Tapis pour l'évacuation de copeaux et chutes



Mobile PC console
Beweglicher Pult für PC
Console mobile pour le PC

JET MASTER 20

TECHNICAL DATA – TECHNISCHE DATEN – DONNÉES TECHNIQUES

TECHNICAL DATA - TECHNISCHE DATEN - DONNÉES TECHNIQUES				Master 20 WF	Master 20 WF XL	Master 20 WF XXL
X Axis	Achse X	Axe X	mm	3300	4800	6700
Y Axis	Achse Y	Axe Y	mm	1550	1550	1550
Z Axis	Achse Z	Axe Z	mm	330	330	330
Max. electrospindle power	Max. Leistung Elektroschmelze	Puissance max. électrobroche	kw	11	11	11
Max. power installed	Max. installierte Leistung	Puissance max. installé	Kw	28	28	28
Vacuum pump capacity	Leistung Vakuumpumpe	Puissance pompe à vide	m ³ /h	90-250	90-250	90-250
Compressed air pressure	Druckluft	Pression air comprimé	KPa	0,6	0,6	0,6
Compressed air consumption	Verbrauch Druckluft	Consommation air comprimé	NI/1	210	210	210
Compressed air connection	Anschluß Druckluft	Prise air comprimé	Gas	1/2"	1/2"	1/2"
Dust extraction outlet diameter	Durchmesser Absaugstutzen	Diamètre bouches d'aspiration	ø mm	ø 250	ø 250	ø 250
Extraction air consumption	Luftverbrauch	Consommation air aspiration	m ³ /h	3400	3400	3400
Extraction air speed	Luftgeschwindigkeit	Vitesse air aspiration	m/s	28/30	28/30	28/30
Machine weight	Maschinengewicht	Poids machine	Kg	5000	6500	8000

			L	W	H
MASTER 20	WF	mm	7700	5100	3250
MASTER 20	WF XL	mm	9100	5100	3250
MASTER 20	WF XXL	mm	11000	5100	3250

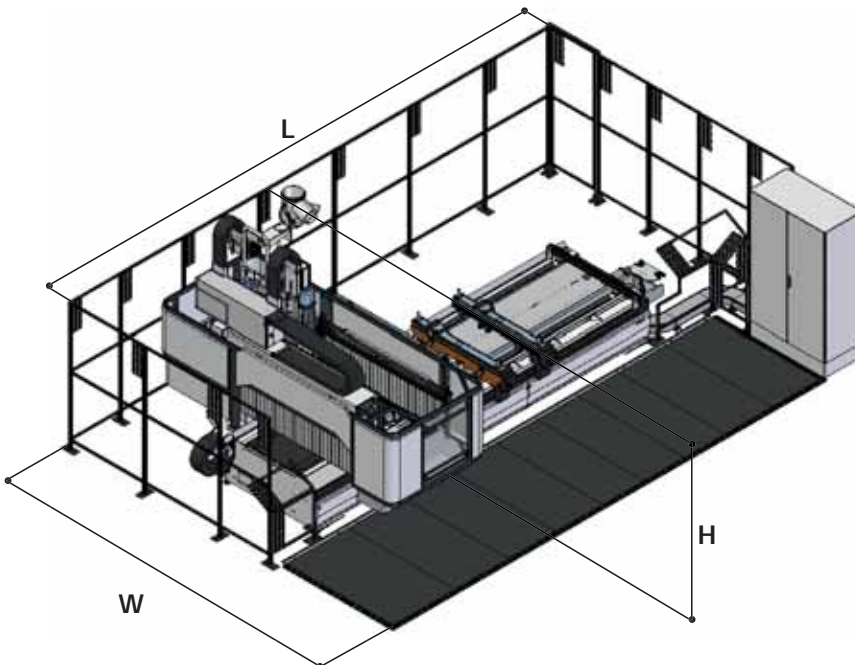

JET MASTER 20 RT

TECHNICAL DATA – TECHNISCHE DATEN – DONNÉES TECHNIQUES

TECHNICAL DATA - TECHNISCHE DATEN - DONNÉES TECHNIQUES				Master 20 RT WF	Master 20 RT WF XL	Master 20 RT WF XXL
X Axis	Achse X	Axe X	mm	3296	4796	6716
Y Axis	Achse Y	Axe Y	mm	1556	1556	1556
Z Axis	Achse Z	Axe Z	mm	350	350	350
Max. electrospindle power	Max. Leistung Elektroschmelze	Puissance max. électrobroche	kw	11	11	11
Max. power installed	Max. installierte Leistung	Puissance max. installé	Kw	28	28	28
Vacuum pump capacity	Leistung Vakuumpumpe	Puissance pompe à vide	m3/h	90-250	90-250	90 250
Compressed air pressure	Druckluft	Pression air comprimé	KPa	0,6	0,6	0,6
Compressed air consumption	Verbrauch Druckluft	Consommation air comprimé	NI/1	210	210	210
Compressed air connection	Anschluß Druckluft	Prise air comprimé	Gas	1/2"	1/2"	1/2"
Dust extraction outlet diameter	Durchmesser Absaugstutzen	Diamètre bouches d'aspiration	ø mm	ø 250	ø 250	ø 250
Extraction air consumption	Luftverbrauch	Consommation air aspiration	m3/h	3400	3400	3400
Extraction air speed	Luftgeschwindigkeit	Vitesse air aspiration	m/s	28/30	28/30	28/30
Machine weight	Maschinengewicht	Poids machine	Kg	5000	6500	8000

			L	W	H
MASTER 20 RT	WF	mm	7700	5100	3250
MASTER 20 RT	WF XL	mm	9100	5100	3250
MASTER 20 RT	WF XXL	mm	11000	5100	3250

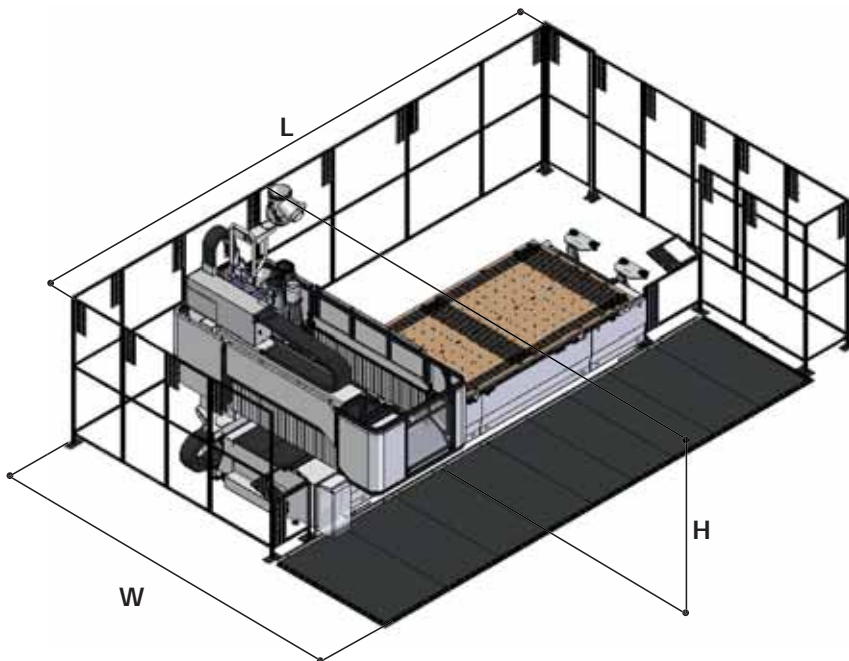

JET MASTER 25

TECHNICAL DATA – TECHNISCHE DATEN – DONNÉES TECHNIQUES

TECHNICAL DATA - TECHNISCHE DATEN - DONNÉES TECHNIQUES				Master 25 WF	Master 25 WF XL	Master 25 WF XXL
X Axis	Achse X	Axe X	mm	3300	4800	6700
Y Axis	Achse Y	Axe Y	mm	1550	1550	1550
Z Axis	Achse Z	Axe Z	mm	300	300	300
Max. electrospindle power	Max. Leistung Elektroschmelze	Puissance max. électrobroche	kw	15	15	15
Max. power installed	Max. installierte Leistung	Puissance max. installé	Kw	28	28	28
Vacuum pump capacity	Leistung Vakuumpumpe	Puissance pompe à vide	m ³ /h	90-250	90-250	90-250
Compressed air pressure	Druckluft	Pression air comprimé	KPa	0,6	0,6	0,6
Compressed air consumption	Verbrauch Druckluft	Consommation air comprimé	NI/1	210	210	210
Compressed air connection	Anschluß Druckluft	Prise air comprimé	Gas	1/2"	1/2"	1/2"
Dust extraction outlet diameter	Durchmesser Absaugstutzen	Diamètre bouches d'aspiration	ø mm	ø 300	ø 300	ø 300
Extraction air consumption	Luftverbrauch	Consommation air aspiration	m ³ /h	3800	3800	3800
Extraction air speed	Luftgeschwindigkeit	Vitesse air aspiration	m/s	28/30	28/30	28/30
Machine weight	Maschinengewicht	Poids machine	Kg	5000	6500	8000

			L	W	H
MASTER 25	WF	mm	7700	5100	3250
MASTER 25	WF XL	mm	9100	5100	3250
MASTER 25	WF XXL	mm	11000	5100	3250

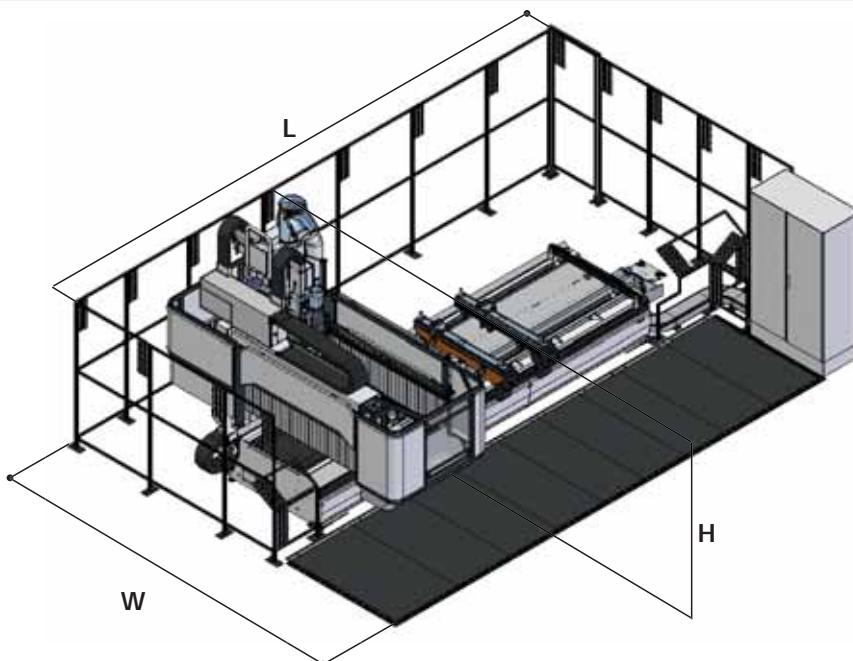

JET MASTER 25 RT

TECHNICAL DATA – TECHNISCHE DATEN – DONNÉES TECHNIQUES

TECHNICAL DATA - TECHNISCHE DATEN - DONNÉES TECHNIQUES				Master 25 RT WF	Master 25 RT WF XL	Master 25 RT WF XXL
X Axis	Achse X	Axe X	mm	3296	4796	6716
Y Axis	Achse Y	Axe Y	mm	1556	1556	1556
Z Axis	Achse Z	Axe Z	mm	350	350	350
Max. electrospindle power	Max. Leistung Elektroschindel	Puissance max. électrobroche	kw	15	15	15
Max. power installed	Max. installierte Leistung	Puissance max. installé	Kw	28	28	28
Vacuum pump capacity	Leistung Vakuumpumpe	Puissance pompe à vide	m3/h	90-250	90-250	90 250
Compressed air pressure	Druckluft	Pression air comprimé	KPa	0,6	0,6	0,6
Compressed air consumption	Verbrauch Druckluft	Consommation air comprimé	NI/1	210	210	210
Compressed air connection	Anschluß Druckluft	Prise air comprimé	Gas	1/2"	1/2"	1/2"
Dust extraction outlet diameter	Durchmesser Absaugstutzen	Diamètre bouches d'aspiration	ø mm	ø 300	ø 300	ø 300
Extraction air consumption	Luftverbrauch	Consommation air aspiration	m3/h	3800	3800	3800
Extraction air speed	Luftgeschwindigkeit	Vitesse air aspiration	m/s	28/30	28/30	28/30
Machine weight	Maschinengewicht	Poids machine	Kg	5000	6500	8000

			L	W	H
MASTER 25 RT	WF	mm	7700	5100	3250
MASTER 25 RT	WF XL	mm	9100	5100	3250
MASTER 25 RT	WF XXL	mm	11000	5100	3250

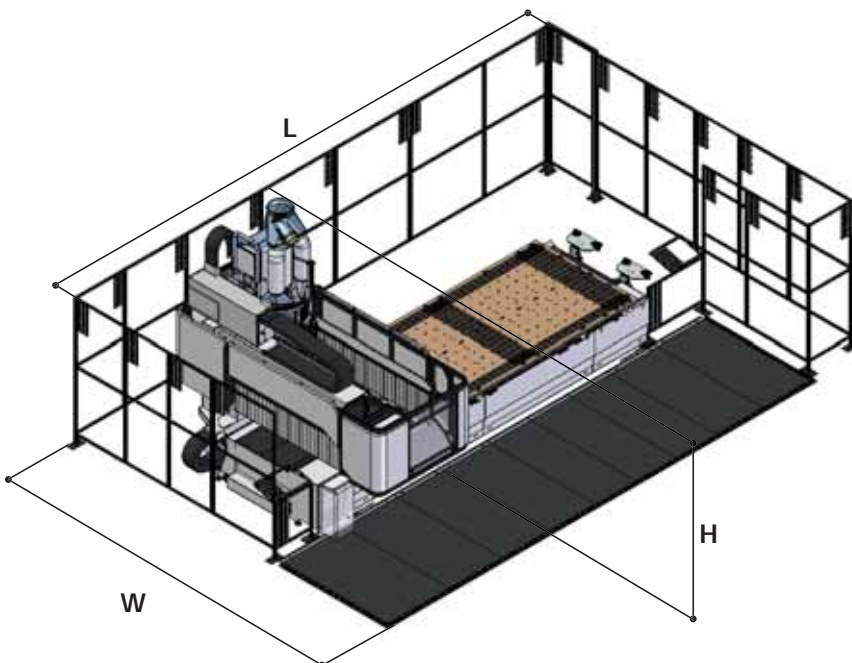

JET MASTER

TECHNICAL DATA – TECHNISCHE DATEN – DONNÉES TECHNIQUES

NOISE LEVELS - ANGABEN ZU GERÄUSCHPEGEL - NIVEAUX DE BRUIT			DRILLING CYCLE BOHRUNG PERÇAGE	ROUTING CYCLE FRÄSUNG FRAISAGE
Acoustic power while the machine is idling ISO 3746-1995 dB(A)	Leistung Geräuschpegel im Leerlauf gemäß ISO 3746-1995 dB(A)	Niveau de puissance acoustique à vide ISO 3746-1995 dB(A)	73,5 dB(A)	67,1 dB(A)
Acoustic power with the machine running ISO 3746-1995 dB(A)	Leistung Geräuschpegel in Arbeit gemäß ISO 3746-1995 dB(A)	Niveau de puissance acoustique avec la machine au travail ISO 3746-1995 dB(A)	76,4 dB(A)	80,6 dB(A)
The maximum instantaneous noise level pressure is under 130 dB (C)	Maximaler Wert augenblicklicher, gewogener, akustischen Druck niedriger als 130 dB (C)	La maximum valeur de la pression instantanée acoustique est inférieure à 130 dB (C)	92,3 dB W(A) 1,7 mW(A)	90,6 dB W(A) 1,1 mW(A)
The measurements were taken with the suction system running, in compliance with the EN 848-3:2007 + A2:2009 standards under the specified test conditions, using the recommended materials and measuring instruments.			Die Messungen wurden mit eingeschalteter Absaugung durchgeführt, in Übereinstimmung mit der Norm EN 848-3:2007 + A2:2009 für das Probematerial, Meßbedingungen und Instrumente.	
			Les mesures ont été prises avec l'aspirateur en fonction et selon les normes EN 848-3:2007 + A2:2009, pour ce qui concerne les matériaux d'essais, les conditions dans lesquelles les mesures ont été prises et les instruments utilisés.	

Busellato offers teleservice via an internet based remote connection as standard on all its working centers.

Alle Busellato Maschinen sind mit einem kostenlosen Internet-Teleservice ausgestattet.

Busellato met à la disposition du client la téléassistance avec connexion Internet standard sur tous les centres d'usines.



GENESIS EVOLUTION

INTEGRATED SOFTWARE SOLUTIONS – INTEGRIERTE SOFTWARE LÖSUNGEN – SOLUTIONS LOGICIELLES INTEGREES

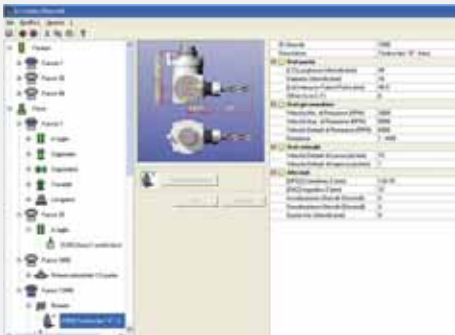

Installed on a Microsoft operating system, it manages the real-time control of the machine and offers a screen based user interface typical of the Windows operating systems.



Installation auf Betriebssystem Microsoft mit Verwaltung Echtzeit der Maschine. Schnittstellenverbindung mit Benutzer.

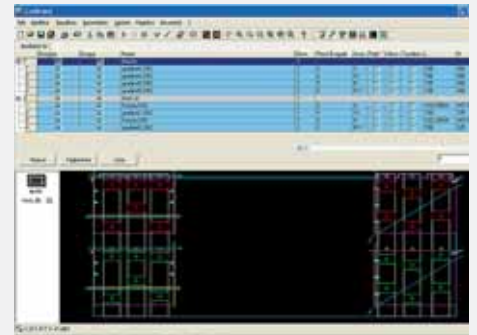

Installé sur système d'exploitation Microsoft, gère le contrôle en temps réel de la machine et offre une interface par fenêtres comme les systèmes d'exploitation Windows.

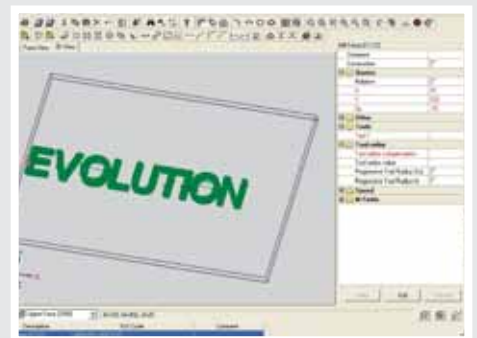
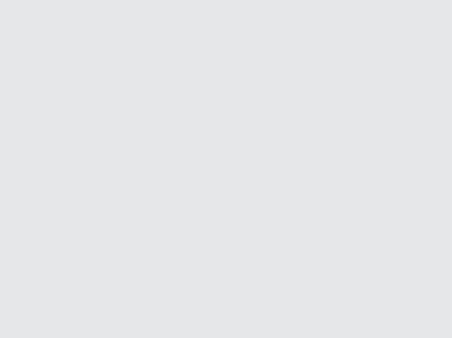
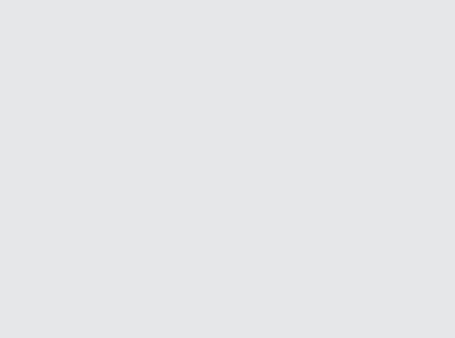
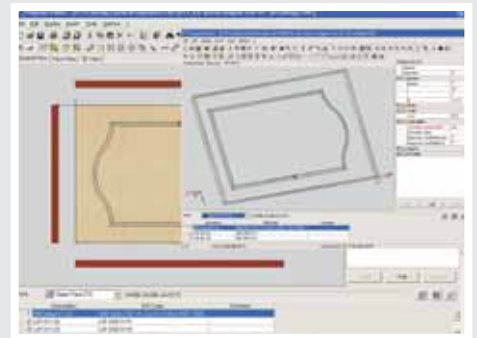
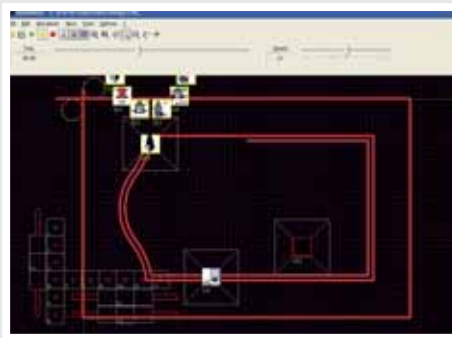
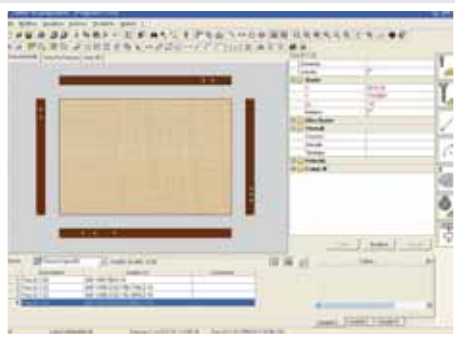

- The 3D editor has been designed to give the user a powerful and immediate instrument.
- 3-D display of the programmed machinings.
- Display of the virtual faces in the 3-D model.
- Parametric programming of programs and sub-routines.
- Compatible with files from previous Genesis versions.
- Importation and conversion of CAD files in DXF format.
- Machining toolbar and "Macro" that can be personalized by the user.
- Character and pocket cycle modules.
- Simulation module.
- Importation of XLS (EXCEL) format files.

- Der 3D Editor ist ein sehr hilfreiches Instrument für den Bediener.
- Dreidimensionale Darstellung der programmierten Bearbeitungen.
- Dreidimensionale Darstellung von virtuellen Flächen.
- Parametrische Programmierung von Programme und Unterprogramme.
- Kompatibilität mit vorherigen Genesis Versionen.
- Importieren und umwandeln von CAD Files in DXF Dateien.
- Funktionsleiste der Bearbeitungen und "Macro" mit Gestaltung nach persönlichen Bedarf
- Schrift- und Taschenmodul.
- Simulationsmodul.
- XLS (EXCEL) Dateien importieren.

- L'éditeur 3D a été conçu et réalisé pour donner à l'opérateur un moyen puissant et immédiat.
- Affichage tridimensionnel des usinages programmés.
- Affichage des surfaces virtuelles dans le modèle tridimensionnel.
- Programmation paramétrique des programmes et des sous-programmes
- Compatibilité avec fichiers des versions précédentes de genesis.
- Importation et conversion de fichiers CAD en format DXF.
- Barre des outils des usinages et des sous-programmes personnalisable.
- Module pour caractères et vidages poches.
- Module de simulation.
- Importation de fichiers format XLS (EXCEL).

JET WINDOWS

INTEGRATED SOFTWARE SOLUTIONS – INTEGRIERTE SOFTWARE LÖSUNGEN – SOLUTIONS LOGICIELLES INTEGREES

Software solution for designing both standard and special door/window frames, even of irregular shapes. Studied for creating linear, inclined and arched door/window frames. It allows the production of the door/window frame to be controlled, from cutting of the parts to insertion of the hardware.

Softwarelösung für Standard- und Spezialfenster. Es ermöglicht rechtwinklige, schräge und Bogenfenster zu machen. Mittels dieser Software realisiert man das Fenster, einschließlich der Schnittliste für die Elemente bis zu alle Beschlagbearbeitungen.

Solutions logicielles pour le projet de portes et fenêtres standard et spéciales, même de forme irrégulière. Les solutions ont été étudiées pour la création d'huisseries linéaires, inclinées ou bien en arc, et permettent de gérer la réalisation de la fenêtre ou de la porte de la liste de découpe des éléments jusqu'à l'usinage pour les ferrements.

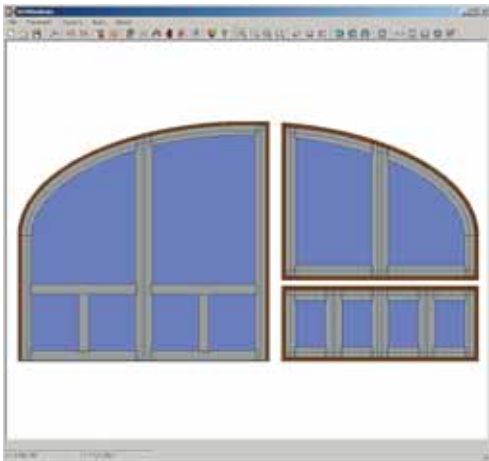

Gross elements cutting list
Schnittliste der Elemente
Liste de découpe des éléments bruts



Joint machining
Verbindungsbearbeitungen
Usinages de jonction



Glazing bead calculation
Berechnung des Glasleistenschnitts auf Maß
Calcul découpe du petit bois



Machinings for hardware insertion



Beschlagbearbeitungen

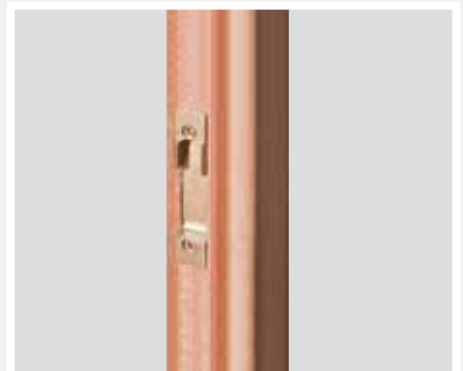

Usinages pour les ferrements

JET CABINET

INTEGRATED SOFTWARE SOLUTIONS – INTEGRIERTE SOFTWARE LÖSUNGEN – SOLUTIONS LOGICIELLES INTEGREES

Software solution for designing and realizing cabinets for home and office furniture with automatic generation of programs and work lists.

Das Schrankmodulsystem ist eine intuitiv bedienbare Software für die Planung, Konstruktion, Kalkulation und Vorbereitung von Möbelstücken.

Solution logicielle pour le projet et la réalisation d'armoires pour l'ensemble et pour le bureau à production automatique de programmes et listes d'usage.

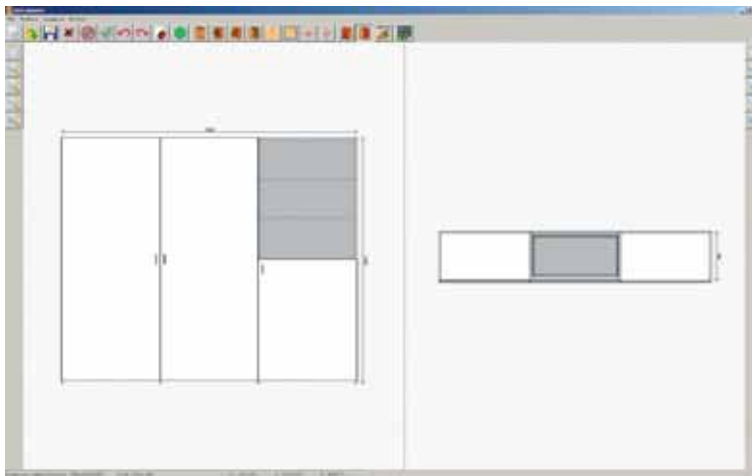

Partitions and shelves
Trennwände und Regale
Cloisons verticales et étagères

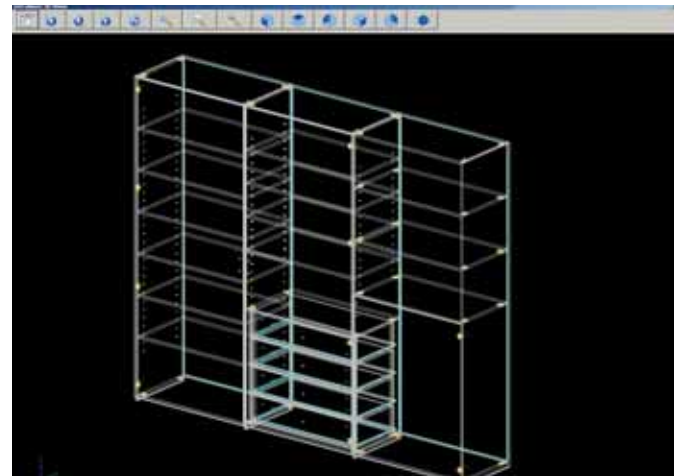

Doors, drawers and backs
Türen, Schubladen und Rückwände
Portes, tiroirs et dosserets

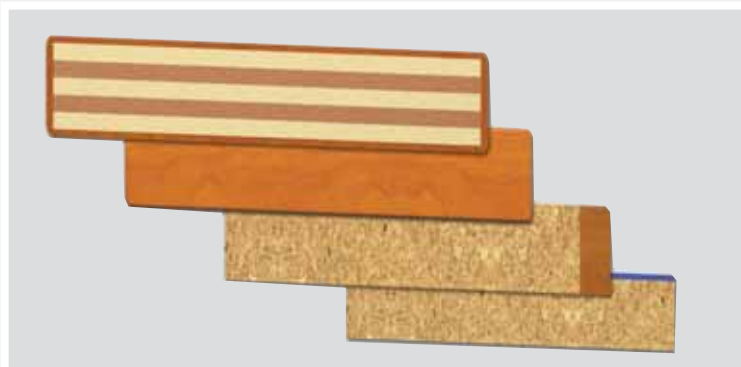

Material and edging storage
Archiv für Materialien und Kanten
Archives de matériel et chants



Parts list with sizes and costs
Werkstückliste mit Abmessungen und Kosten
Liste des éléments avec dimensions et coûts



0000569297H

Rev.n. 00 - 04/2010 - Acantb Comunicazione - Olimpia



CASADEI - BUSELLATO
Via del Lavoro 1/3 - Po box 168
36016 Thiene - Vicenza - Italy
T. +39 0445 690000 - F. +39 0445 652400
info@casadeibusellato.com
www.casadeibusellato.com