

## formula X

DM SYSTEM

The new standard in panel sizing

The most unique panel saw in the world is capable of automatically adapting the saw grippers to different cutting patterns, panel sizes and formats.

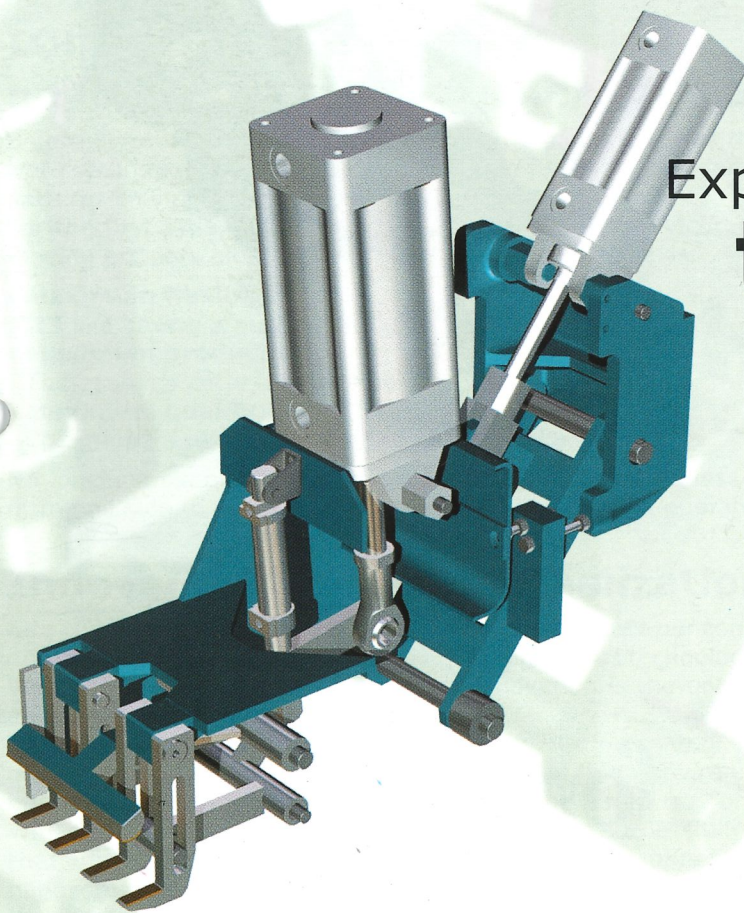

Expression of  
**technology**

a ROBOT for a partner

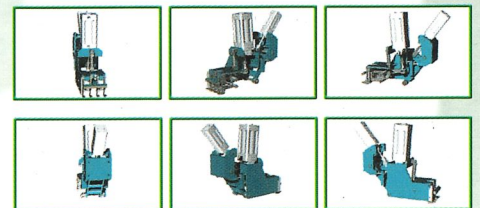

**Editorial** Innovation through specialization

**Focus** Giben formula X<sup>SPT</sup>, the new standard in panel sizing

**Focus** Giben PM System, a robot for a partner

**Focus** New G DRIVE<sup>RT</sup> controller

**Focus** Highlights of innovation from Giben

**Focus** The right choice in Alberta, Canada

**Focus** A wide range of panel saws to meet every need



# Contents

## Editorial

Innovation through specialization ..... page 3

## Focus

Giben formula X<sup>SPT</sup>,  
The new standard in  
panel sizing ..... page 4

## Focus

Giben PM System,  
A robot for a partner .... page 6

## Focus

New controller for  
panel sizing  
G DRIVE<sup>RT</sup> ..... page 7

## Focus

Leadership in  
innovation ..... page 10

## Focus

The right choice in  
Alberta, Canada ..... page 10

## Focus

Panel saws for every  
requirement ..... page 11

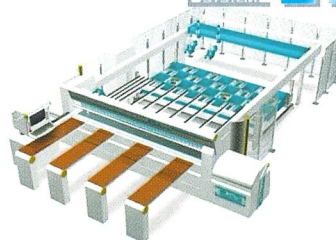
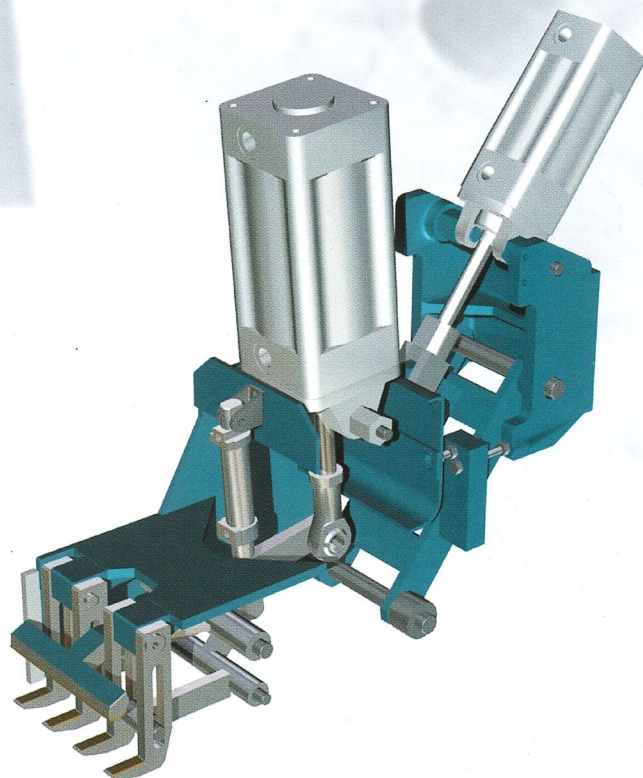

Index



# Editorial

## A grateful thanks you to our customers.

Welcome from all the staff at Giben!

We published the Giben Magazine for several reasons:

First, we want to express our gratitude to all our customers for having chosen Giben panel saws, thanks to you, we have been able to achieve excellent sales and market share. We wish to take advantage of the change in panel saw design we set in motion at this year's Xylexpo in Milan. Starting today, Giben will define the new standard in panel sizing with our new series, the **Formula X**.

## The futur is formula X

During the past several years, the evolution of the panel saw has produced increased outputs and speeds. So, where will all this lead? The simple answer is **Formula X**, the most advanced technology in the world.

A machine able to offer maximum balance of: **FLEXIBILITY and PRODUCTIVITY**.

With an excellent tradition behind it, the new Giben Formula X series confirms Giben's leadership in the world market.

## formula X

### no longer a simple pusher. It's a robot.

Before Formula X, the main problem with a panel saw was that its grippers were set in fixed positions instead of being flexible. Considering that cutting patterns change 20 - 40 times a day, this is a problem.

For the first time, Giben has solved this problem by incorporating 2 large moving grippers along the width of the pusher's "X" axis.

- **Maximum flexibility**

It's like having a pusher with grippers everywhere.

- **Maximum productivity**

The pusher's cycle time has been reduced.

- **Maximum quality**

The grippers never damage the panel's edge.

No longer a simple pusher, but a ROBOT with hefty tireless hands moving from one side to the other, constantly working for the operator.

## Innovation through specialization

As a company strategy, we have decided to concentrate our complete attention on solving panel sizing problems through continuous technological innovation. We know that continual technological innovation is the only way to remain competitive in today's global marketplace.

To be competitive, new ideas are a necessity. Unfortunately, new ideas don't grow on trees, rather, they must be cultivated in an environment free from bureaucracy and bias. In short, there must be a new way of thinking.

With the introduction of **Formula X**, Giben has successfully demonstrated that innovation born from focused attention on panel sizing pays off handsomely for our customers. Now, there is a justifiable reason to replace those older, less productive saws.

*Piergiorgio Benuzzi*



**Giben Magazine**  
Newsletter Giben Impianti S.p.A.  
no. 1 - May 2000

**Special Edition 2000**

CHIEF EDITOR

**Stefano Conti**

E-mail: [gibenimpianti@giben.it](mailto:gibenimpianti@giben.it)

CONTRIBUTORS TO  
THIS ISSUE:

**Piergiorgio Benuzzi**

**Stefano Conti**

**Bob Schiemetat**

DESIGN & PRODUCTION

**Graphic Live**

[www.graphiclive.com](http://www.graphiclive.com)

PICTURES AND DRAWINGS

**Industrialfoto**

**CAT multimedia**



# Giben formula X<sup>SPT</sup>

The new standard in Panel Sizing

## Giben formula X

Represents the most unique panel saw in the world, where grippers have been made adaptable to different cutting patterns and types of panels.

## Giben formula X

A panel saw always ready to meet your needs today... and into the future. In the past, the main problem with panel saw design has been that

they were equipped with several grippers in fixed positions, instead of being flexible as the machine requires.

Let's face it, cutting patterns change 10 -40 times a day.

Now, Giben has solved this problem by incorporating two large, moving grippers along the width of the pusher's "X" axis.

## Giben formula X

It represents FLEXIBILITY!

Total flexibility and maximum output:

- Up 'till now, the cutting patterns have been adapted to the configuration of the fixed-position grippers on the panel saw.
- With the new Giben Formula X series, grippers can be adjusted to the actual cutting pattern in execution.

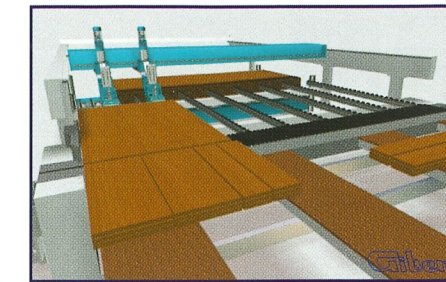
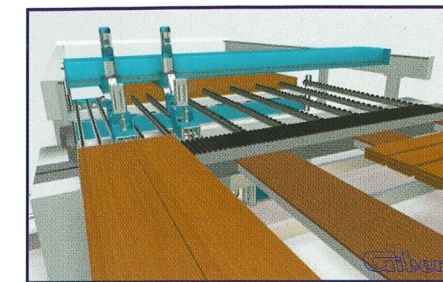
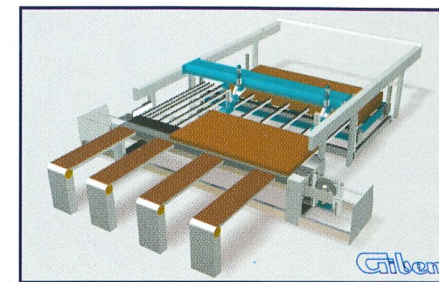

## Giben specialization means innovation

INNOVATIVE and WINNING ideas come from specialization! No more damaged corners from mis-aligned grippers.

## Giben formula X

This unique panel saw will never damage the corners of the panel, thanks to its new system of moving grippers.

These grippers automatically position in the most appropriate location whatever the width of the strips.

To produce more and better with **Giben formula X!**

The ever present problem of damaging panel edges has always caused consternation.

It's very difficult for the operator to check any possible breaking point, because the widths of the strips are always changing.

Whenever a panel is damaged, it becomes useless and has to be replaced. That's lost material and a waste of time.

# Giben formula X<sup>SPT</sup>

## INNOVATION BY GIBEN

This extraordinary flexibility leads to higher output from the new Giben Formula X series -compared to any other panel saw.

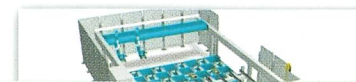
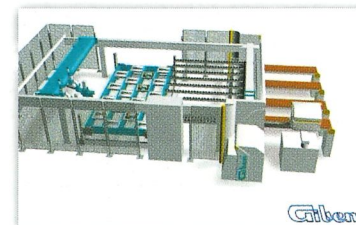
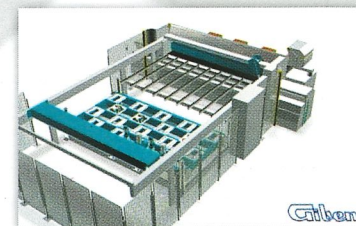
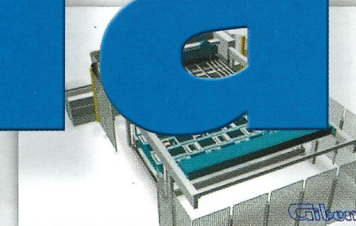
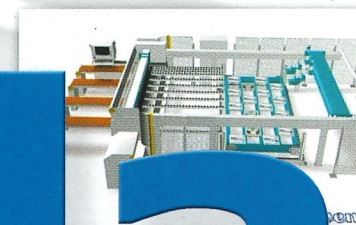
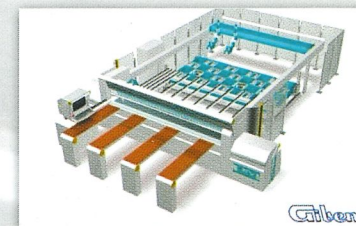
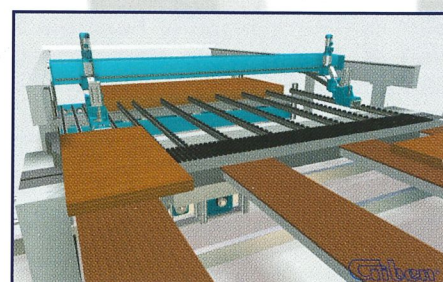
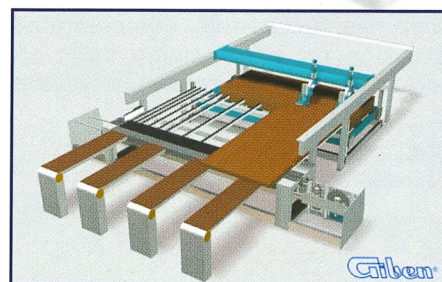
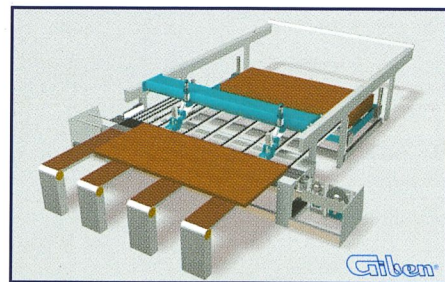

## Technological progress – the benefit of being a SPECIALIST!

The new **Giben Formula X** series is concrete proof that 30 years of specialization in panel sizing pays off – for you.



# PM System a robot for partner

The **PM System**, with its key element, the moving gripper, is controllable along both the width of the pusher (X axis), and along the perpendicular axis to the width of the pusher (Y axis). Based on your specific job, the movement of the grippers can be combined and integrated to add maximum flexibility to your production environment.

Giben has anticipated the problems of multiple jobs with changing requirements. The result:

## GIBEN formula X

This panel saw is equipped with the PM System, controllable in its movement along the width of the pusher (x axis).

With controlled positioning and PM System grippers, it's possible to grip several panels, side-by-side, so that they can be moved and sized together.

In practice, the panel saw becomes a truly *universal format* machine, managed by the operator and the control system, automatically adjusting for the dimension of the boards and strips in every movement. With the proper combination of grippers and the positioning of the pusher (and the grippers), it's possible to obtain higher outputs of sized parts over conventional technology. Fewer cycles translates into higher productivity for your operation.

## ADVANTAGES OF GIBEN PM SYSTEM

### 1. Higher productivity

It is possible to cross cut more strips side-by-side, without the need to add any additional fixed grippers within the width of the pusher. That's because the grippers are always placed in the optimal position for executing a cutting pattern.

### 2. More logical machine cycles

The moving grippers with automatic positioning, group more strips together providing the operator with a more logical material flow.

### 3. Optimization without limitation

There are no limitations on the patterns that can be processed. The "danger" areas with fixed-position grippers have been eliminated by the PM system. In fact, previously cut boards and small portions can be optimized and reused.

### 4. No damage to the corners of the panels caused by improper gripper positioning

Panels often suffer corner damage due to fixed-position grippers. This problem is completely eliminated by the PM System, because it allows for the proper positioning of the grippers in relation to the changing dimensions of panels and cutting patterns.

### 5. Fewer number of saw carriage and pusher movements

Because more strips can be placed side-by-side, there are fewer numbers of cycles and movements of the saw carriage and pusher.

### 6. Long term solution

There is no need to ever replace or modify the machine. Only the panel formats need change. The PM system is the solution that will meet your needs today, and well into the future.



# The new G-DRIVE<sup>RT</sup> machine controller

# G-Drive<sup>RT</sup>

Giben's brand new CNC series is based on the highly stable Window NT<sup>®</sup>, operating system and provides a glimpse of the real nature of change in the new Giben panel saw control system. It's the unique control system with SGT, real-time graphic simulation.

- Pentium Office PC
- 32 bit System
- Perfect Graphic
- Uses windows and icons
- Preventive diagnostic

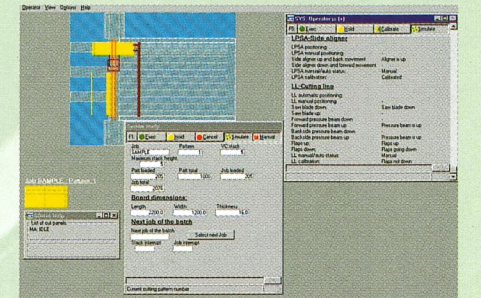

## The G DRIVE<sup>RT</sup> machine control software. Developed by GIBEN, designed to run within Window NT<sup>®</sup>

All of the saw's complex machine movements are controlled directly by the G DRIVE<sup>RT</sup>. The machine layout and the cutting patterns are shown to scale on the screen. During job execution, all machine operations and panel/part movements are displayed on the screen in real time.

Direct control of all machine functions allows for detailed diagnostics and troubleshooting messages for fast problem fixing. Photographs and video sequences of the machine are easy to insert or edit and is further evidence of the advantage of the Window NT<sup>®</sup> operating system.

Maximum automation, easy to program and use, minimum cycle times, automatic data download by network or floppy disk, connection to label printer, 17" color monitor, software can be installed on any personal computer, compatible with any Window NT<sup>®</sup> environment.

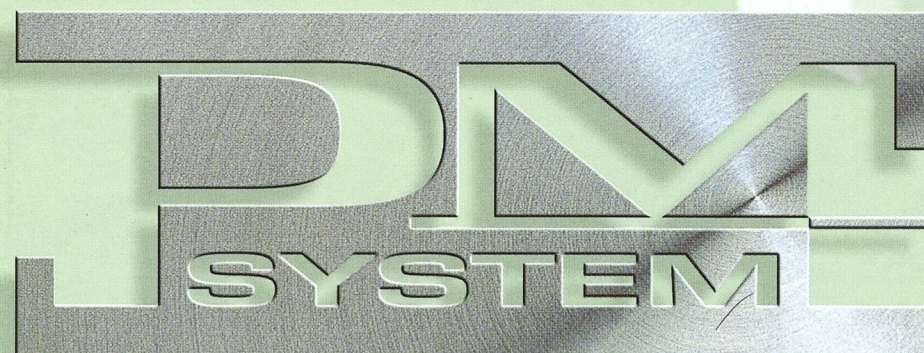
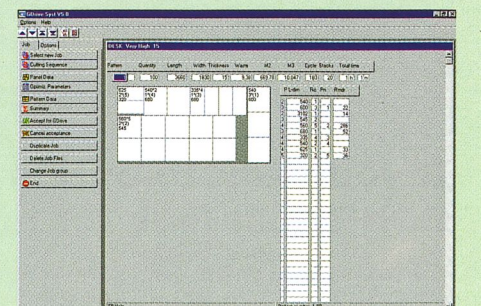



# The ROBOT of panel saws

No longer just a pusher! Instead, two large, tireless hands each with 400kgs of gripping power that ensure a strong hold at the point of contact - but WON'T SCRATCH THE MATERIAL SURFACE.

LOWER BOOK HEIGHT, HIGHER PRODUCTION!

It seems to be a paradox...but it's true!

### Giben formula X

To increase the output of a panel saw, it's really necessary to reduce cycle

times and not just increase the book height. With the Formula X, strips can be placed side-by-side against the square fence, regardless of the gripper's position, and it will always be possible to cross cut patterns at one time.

As an example, even if this were possible with only 50% of the cutting patterns, the reduction in cycle time would be a very significant 25%.

- The Formula X has a greater output than machines with higher stack cutting capacity.

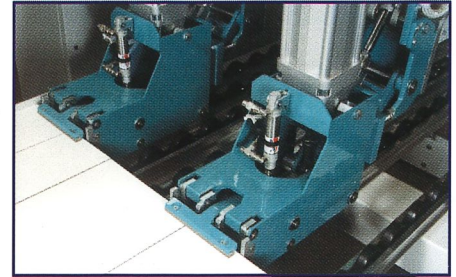
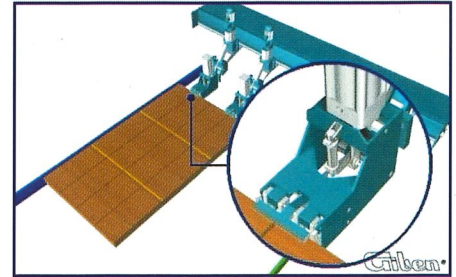

## 5 pusher cycles with traditional panels saws <sup>VS</sup> 3 pusher cycles with Giben formula X

Reducing pusher cycles from 5 to 3 means a 40% savings in cycle times.

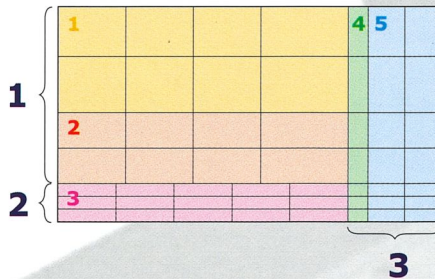

Example:

Comparison	Giben Formula X with 7 panels	Others with 7 panels	Others with 9 panels
Saw projection	132 mm	132 mm	160 mm
Thickness of the board	16 mm	16 mm	16 mm
No. of boards per book	7	7	9
Book height	112	112	144
Average cycle time	5' 6"	9'	9'
Average no. of cycle times per hour	11,7	6,6	6,6
No. of boards per hours	81,9	46,6	59,4
Production %	<b>100%</b>	<b>-43,2%</b>	<b>-27,5%</b>

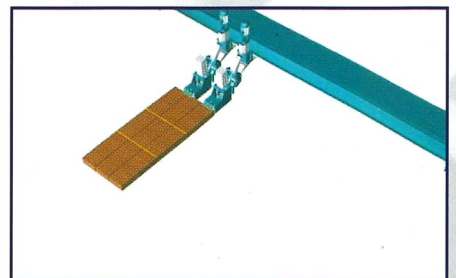
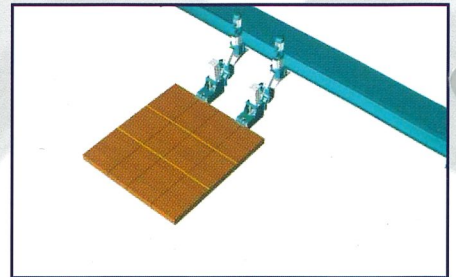
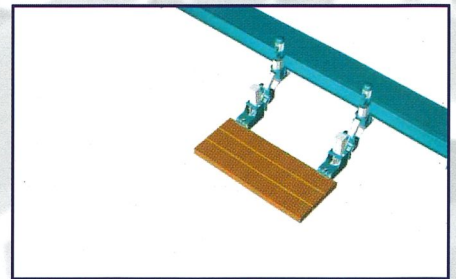

**If you want to obtain an increase in production, DON'T just look for higher book heights!**

The new Giben formula X series with a 112 mm book height (7 panels of 16 mm) yields more than a panel saw with a stack 144 mm (9 panels of 16 mm) high.



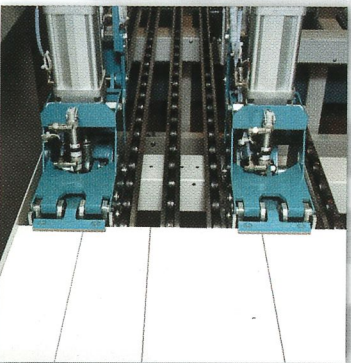
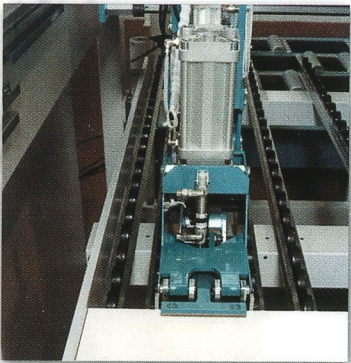
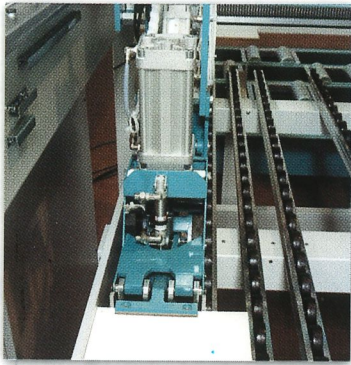
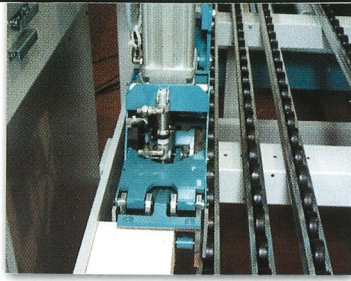

## Rip cutting with the formula X

Sometimes, an example will help to demonstrate that gripper position can be a real problem in a panel saw. With the new **Giben formula X** series, the grippers are always positioned in the optimum location for any given cutting pattern.

**1. The grippers hold the entire board/stack along its long edge in two optimal positions.**

**2. Along its short edge to execute a head cut, again in two ideal positions.**

**3. Along the edge of the portion after the head cut, positioning the grippers at the two optimal points to maintain a firm hold of the board/stack.**

**4. Along the edge of the head cut portion, as required by the specific pattern, regardless of how complicated.**

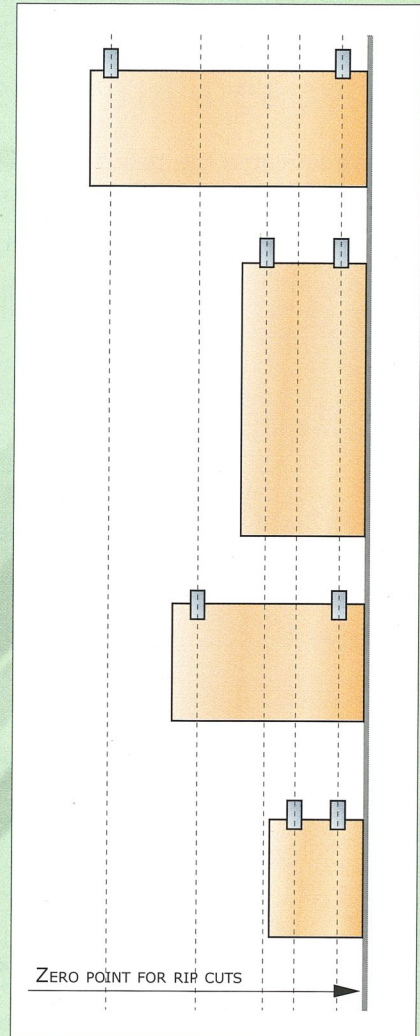

## Become more competitive with Giben formula X technology.

The **Giben formula X**, equipped with the new **G DRIVE<sup>RT</sup>** system, can automatically control gripper position relative to the cutting pattern in process.

INNOVATIVE ideas come from SPECIALIZATION. Giben will continue to be a panel sizing SPECIALIST, providing its customers with technologically superior machines.

## Cross cutting with the formula X

The cross cut fence area is further proof of the **Giben formula X** advantage:

- Panel saws should last at least 10 years
- How can you know today, the number and position of each gripper you'll need for the life of the machine?

It's simple if you only think along these 3 parameters:

- 1.** 4 different strip widths for each cutting pattern;
- 2.** Executing 12 different cutting patterns per hour;
- 3.** 7 hours of machine time per day.











Different positions or combination of strips within one work cycle are estimated to be at least 336. That Is:

- 1,680 different positions in a week
- 6,720 different positions in a month
- 80,640 different positions in a year



# Giben<sup>®</sup> first "Giben highlights"

To our 10,000 customers around the world...Thank You!

-  We invented the beam panel saw 55 years ago this year.
-  We were the first to incorporate a PC computer in a panel saw.
-  The first to apply optimization in panel sizing.
-  The first to apply real-time graphic simulation on a panel saw.
-  The first to use highly compatible office PCs as the saw controller.
-  We invented the double pressure beam for the panel saw.
-  And retractable fingers on pusher grippers.
-  The first to have thin material loading.
-  The first to incorporate dumping tables for offcuts.
-  The first to offer a pneumatic quick blade release.
-  During the Ligna Exhibition in Hannover in 1999, we introduced the world to a new cutting technology for tall book heights, the TETRAMATIC, with 2 main saws and 2 scoring saws in an over/under (opposed) configuration.

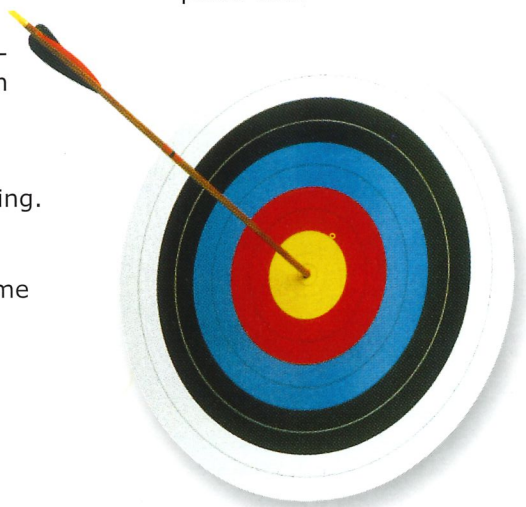

## The Right Choice in Alberta, Canada

Giben is proud to announce that an important board manufacturer in Alberta recently selected the Giben HYPERMATIC because of its long life and dependability. It will be the largest panel saw ever delivered. The new Hypermatic will run 24 hours a day inline with the company's OSB panel press operation.

<i>Board size</i>	7,315 x 4,658 mm
<i>Book height</i>	210 mm
<i>Book weight</i>	3.8 tons
<i>Book composition</i>	High speed Giben nip rollers
<i>Operation</i>	24 hours a day

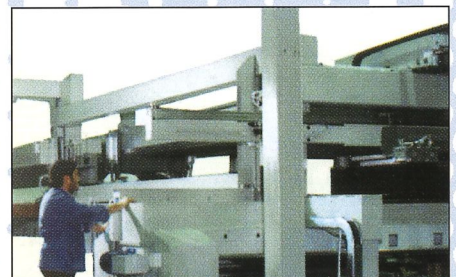

**Giben's high quality panel saws have won the loyalty of many customers over the years.**



# A wide range of saws to meet any requirement

Giben has the widest range of panel saws available, you can be sure that there's one to meet your needs

Because Giben is a panel saw specialist, we understand that you are a specialist too. That's why we've designed saws for virtually every application.

- For **FURNITURE** manufacturers
- **PARTICLEBOARDS** manufacturers
- **MDF** manufacturers
- **HARD BOARDS** manufacturers
- **OSB** manufacturers
- **GYPSUM** manufacturers
- **ALUMINUM** manufacturers
- **COMPOSITE MATERIALS** manufacturers
- **HPL** manufacturers
- **FIBERGLASS** manufacturers
- **CARDBOARD** manufacturers

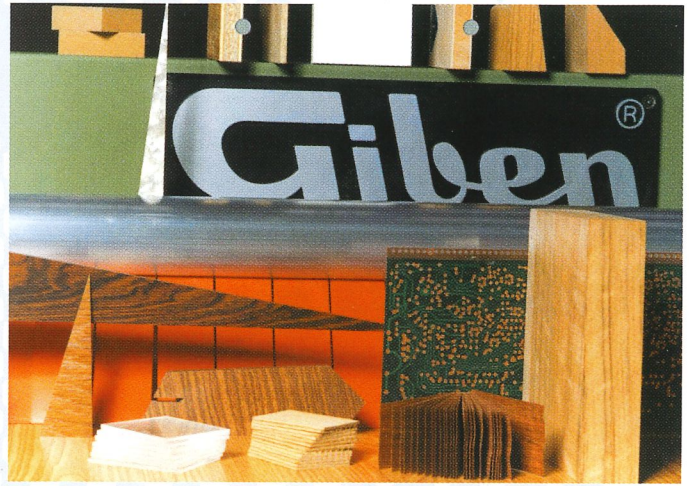

We sell to the most important manufacturing companies all over the world, from Europe to America and South America to Asia, Giben systems are tirelessly working day and night.

## The Giben Panel Saw Line:

- 1.** Starmatic 850/1000 series equipped with grippers  
-h 85  
-h 100  
-h 115
- 2.** Prismatic SP series equipped with grippers  
-h 100  
-h 115  
-h 132
- 3.** Prismatic SPT series equipped with grippers and lift table  
-h 100  
-h 115  
-h 132
- 4.** MATIC 401 SP series equipped with grippers  
-h 172
- 5.** Serie MATIC 401 SPT series equipped with grippers and lift table  
-h 172
- 6.** ALUMATIC series for light alloys
- 7.** PLASMATIC series for plastic materials
- 8.** SIGMATIC series panel sizing centers equipped with grippers  
-h 100  
-h 115  
-h 132
- 9.** SUPERMATIC series panel sizing centers  
-h 172
- 10.** HYPERMATIC panel sizing centers  
-h 217
- 11.** TETRAMATIC high performance panel sizing centers  
-h 220  
-h 310

## And Now...

- The brand new **Formula X** SP and SPT.
- The brand new **Formula S-Type** angular system, equipped with 2/3/4/ cross pusher and a new rotating head cut unit.



# Giben®

...the future is here!

THE GREATEST INNOVATION IN PANEL SIZING IN 25 YEARS!

**New  
TECHNOLOGY**

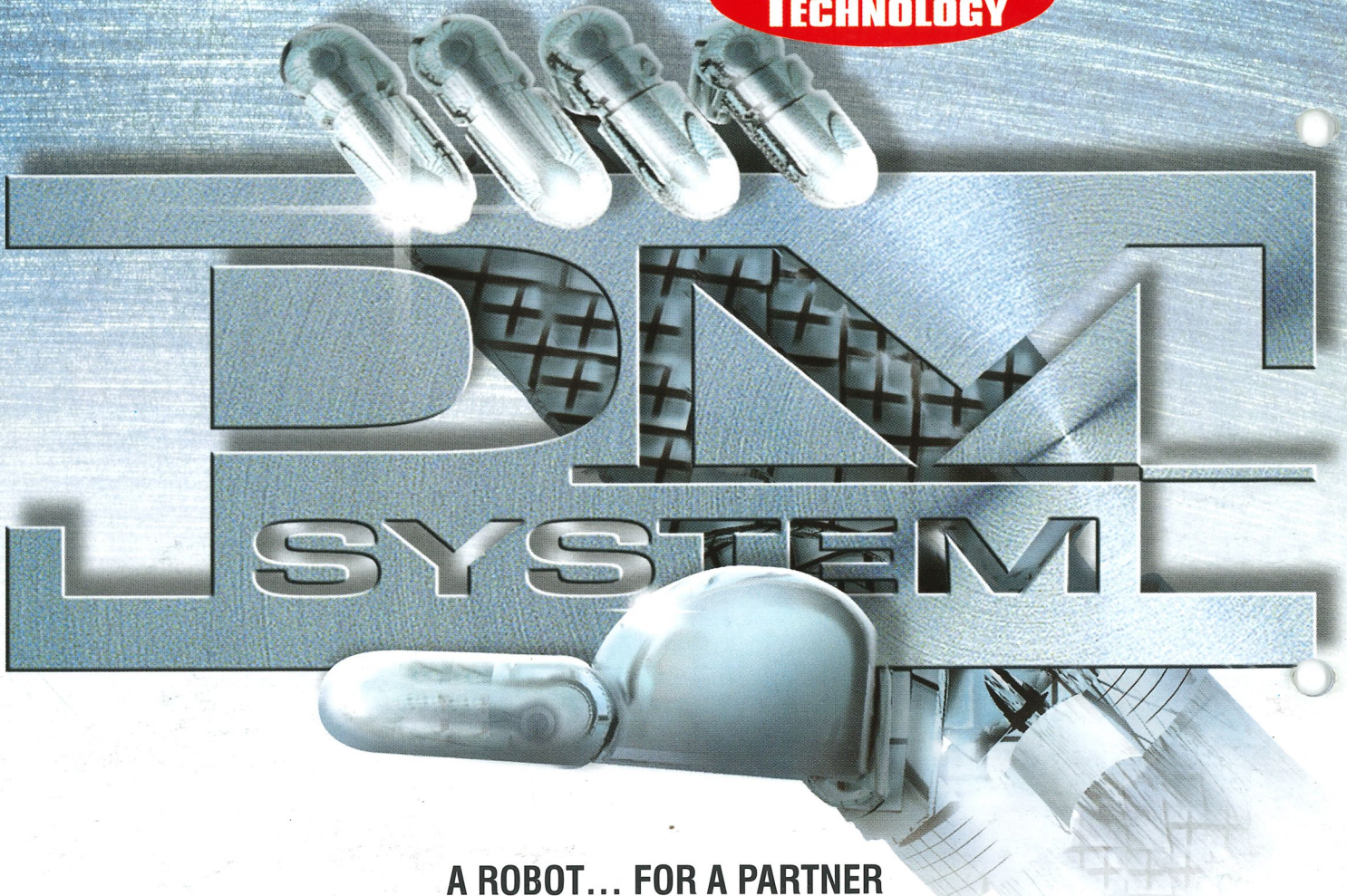

## A ROBOT... FOR A PARTNER

HEFTY, TIRELESS HANDS AUTOMATICALLY POSITION PANELS  
OR GROUPS OF STRIPS IN THE MOST APPROPRIATE POSITION.

AN INNOVATIVE SYSTEM OF MOVING GRIPPERS, USING CONTROLLED  
POSITIONING BY THE G-DRIVE<sup>RT</sup> TO PRODUCE MORE, BETTER, AND FASTER.

**Giben®**

PANEL SIZING MACHINES AND SYSTEMS

HEAD OFFICE:

**GIBENIMPIANTI** S.p.A.  
40065 PIANORO - BOLOGNA - ITALIA  
Ph. +39-0516516400  
Fax +39-0516516425

E-mail: gibenimpianti@giben.it  
www.giben.it  
www.giben.com

IN THE WORLD:

GIBENIMPIANTI  
GIBENAMERICA  
GIBENAUSTRIA  
GIBENdoBRASIL  
GIBENCANADA  
GIBENDEUTSCHLAND  
GIBENdeESPAÑA  
GIBENSCANDINAVIA  
GIBEN U.K.