

Edge banding machines  
Ambition / Highflex / airTec / edition  
Series 1600 – 2600







## Perfect edges for discerning customers manufactured with flexible machines

Individual customer needs and preferences, sophisticated products and a wide range of materials – all factors which play a major role in today's woodworking industry. Here, production flexibility and efficiency are key – particularly for woodworking shops and medium-sized enterprises.

HOMAG offers unbeatable benefits and has a presence on the ground with international production plants and sales and service companies with around 6.000 staff members in over 100 countries around the world. This is the way forward to create with HOMAG a sharp competitive edge and security for your business in the long term.

We are **YOUR SOLUTION**

### Contents

- 04 Ambition series – all inclusive as standard:
- 06 Ambition series 1600, 1800, 2200, 2400, 2600
- 34 Our range of modular units:  
The right solution no matter what the requirement
- 58 BOOMERANG® return feed systems:  
Increased productivity for edge banding machines
- 60 HOMAG Life Cycle Services
- 62 The convenient machine for your requirements:  
Technical data



**Intuitive operation with powerTouch control system**

Using the widescreen format multitouch monitor, you control machine functions by direct touch contact. The ergonomically optimized design and an array of new help and assistant functions substantially simplify operation.



**Top pressure belt**

The top pressure beam made of steel with double V-belt forms the basis for outstanding quality, as it ensures that workpieces are ideally clamped for processing.



**Multi-stage technology**

For simple profile change by push button. Saves time and improves quality.



**Controlled chip capture**

The chips are extracted already in the interior and selectively directed to the extraction hood. Greater economy and a longer service life due to reduced wear and lower service costs. Reduced extraction speed drives down energy consumption and costs.

## Ambition series – all inclusive as standard

**THE MOST IMPORTANT FEATURES OF THE MODELS.** The Ambition series is characterized by its comprehensive equipment standard: Top pressure for precision workpiece guidance, optimized trimming tools for optimum chip disposal and perfect processing quality. Variable feed rates in various performance categories for high productivity. All the machines of the Ambition series can also be extended. Additional processing units such as grooving or belt sanding can be mounted on selected machines which come with a free space. HOMAG Ambition machines are energy-saving and environmentally friendly.

- **High-grade furniture with high edge quality**
- **More output through high availability**
- **Low energy requirement**
- **Outstanding economy**
- **Optimum cost-to-performance ratio**

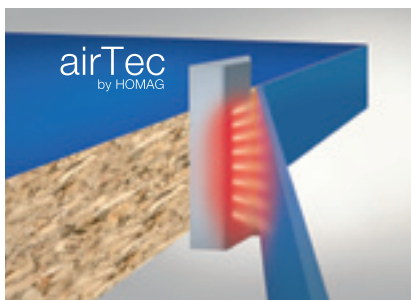

### **Zero joint technology with HOMAG airTec**

The units are now equipped with a rotary air heater which makes the process significantly more efficient and quieter as well as saving resources.

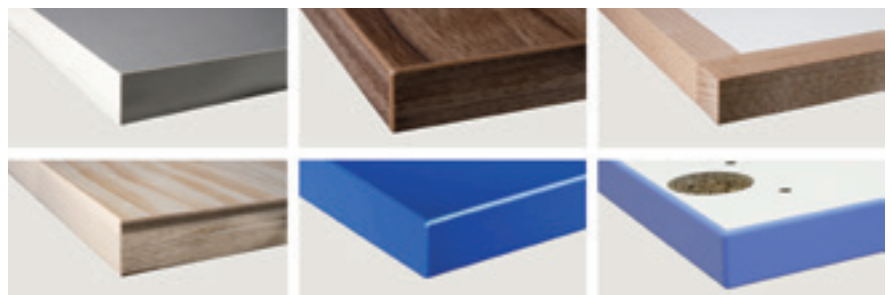

### **Wide range of materials**

High flexibility is achieved as almost all materials can be processed: 0,4 mm melamine, 2 mm PVC, 20 mm solid strips, veneer, high gloss, nesting.

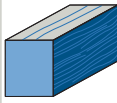
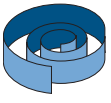
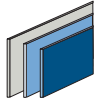
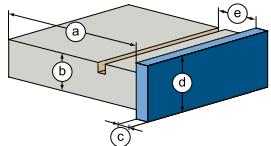
	SOLID (mm)	COILS (mm)	STRIPS (mm)
			
<b>a</b>	with b = 22: min. 70 with b = 40: min. 125		
<b>b</b>	8 – 60		
<b>c</b>	0.4 – 12	0.4 - 3.0	
<b>d</b>	65		
<b>e</b>	max. 30 (only Ambition 1660 FGC)		
			

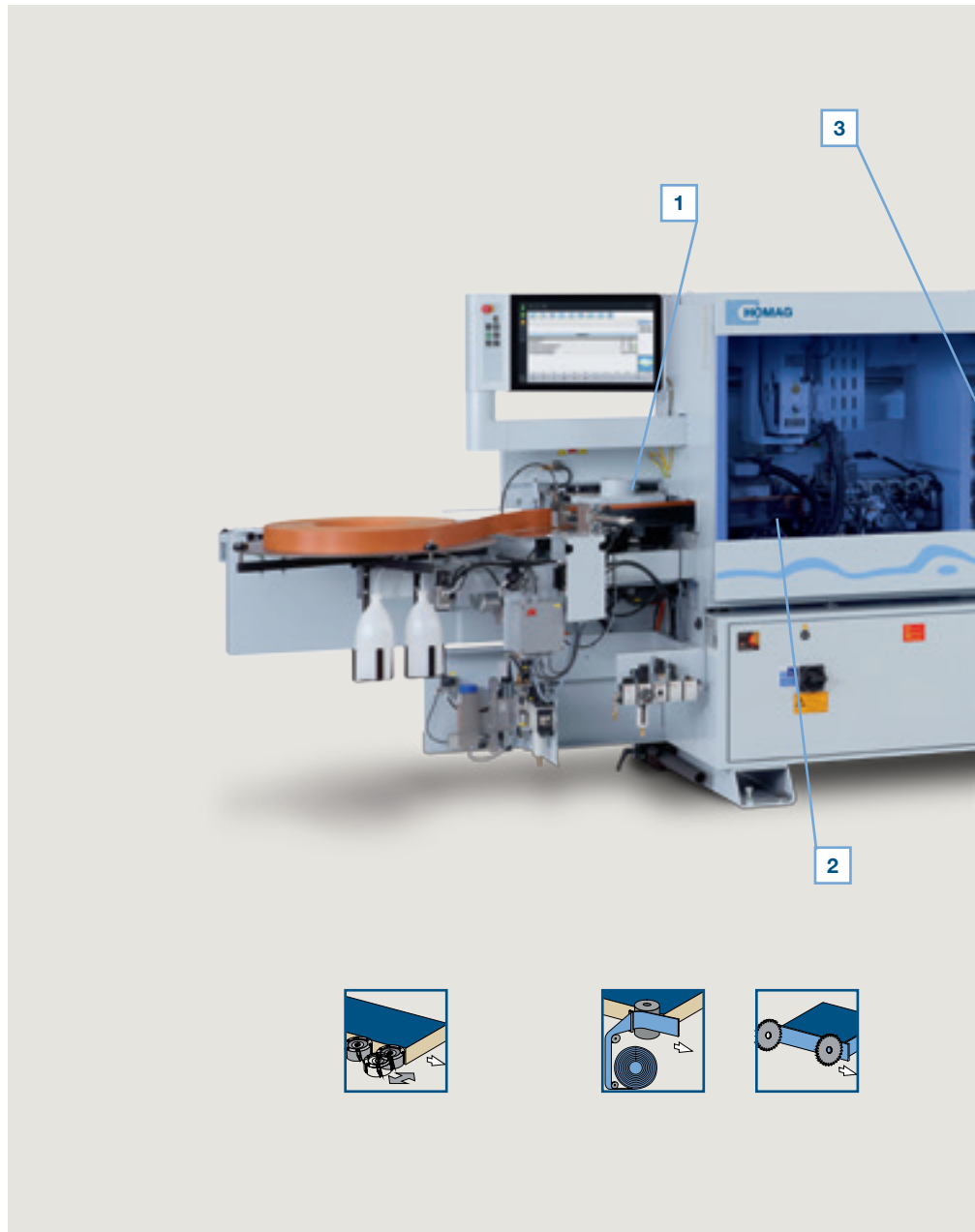

## Ambition 1650 FC and 1660 FGC: Setting standards in performance and quality

The basic machine is equipped with a precise gluing section, a 2-motor snipping unit, a trimming tool and a profile trimming tool. A radius scraper unit and a buffing unit ensure a perfect finish. The high-powered motors of all the units ensure the unrestricted strength required for processing the broad product spectrum. To allow the optimum solution to be offered for every requirement, a jointing trimming unit, a swivel-action grooving unit (Ambition 1660 FGC) and a

glue joint scraper unit are available for the machines. With the optional Quickmelt gluing section, optional workpiece gap optimization for even more effective production and the available separating and cleaning agents, this series is ideally equipped to cope with every conceivable requirement.

**Feed speed: 8 – 18 m/min (20 optional)**

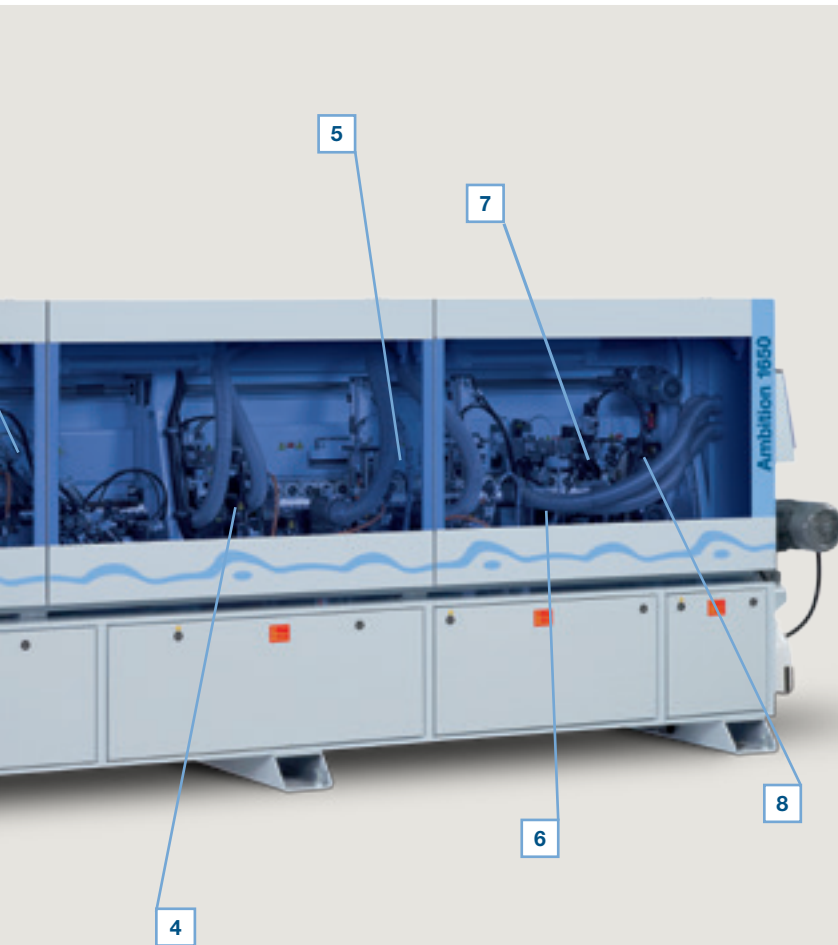

**Ambition 1650 FC**

- 1** Jointing trimming unit
- 2** Gluing unit
- 3** Snipping unit
- 4** Trimming unit
- 5** Profile trimming unit
- 6** Profile scraper unit with quick-change heads
- 7** Free space glue joint scraper unit
- 8** Buffing unit

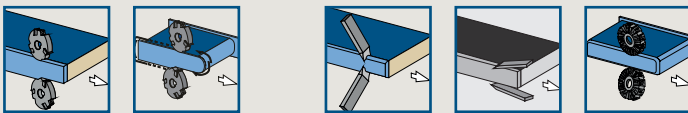

**Option**

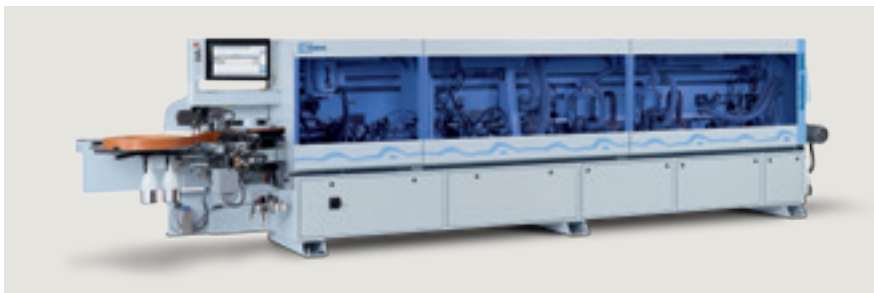

**Ambition 1660 FGC**

Same equipment as Ambition 1650 FC plus a grooving unit.

**MATERIAL TYPES**

- e.g.
- 0.4 mm melamine
  - 2 mm ABS
  - Veneer (coil)
  - 12 mm solid strips
  - High gloss (option)
  - Nesting (option)

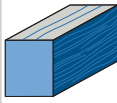
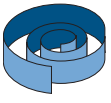
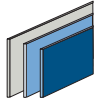
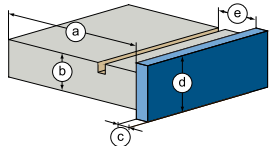
	SOLID (mm)	COILS (mm)	STRIPS (mm)
			
<b>a</b>	with b = 22: min. 70 with b = 40: min. 125		
<b>b</b>	8 – 60		
<b>c</b>	0.4 – 12	0.4 – 3	
<b>d</b>	65		
<b>e</b>	max. 30 (only Ambition 1670 FSCG)		
			

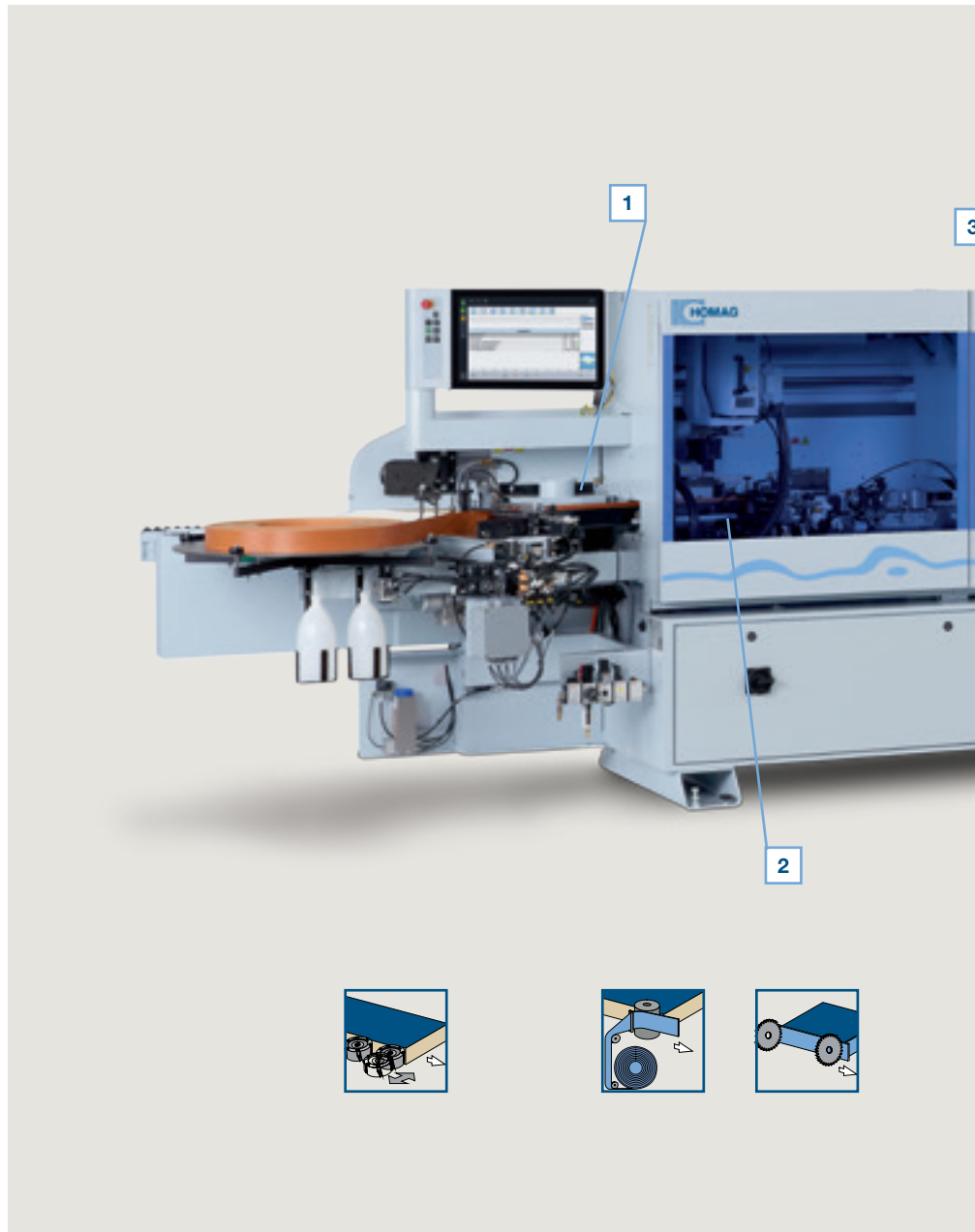

## Ambition 1660 FSC and 1670 FSCG: Setting standards in performance and quality

The basic machine is equipped with a precise gluing section, a 2-motor snipping unit, a trimming unit and a Servotrim profile trimming unit for corner rounding and flush trimming. A radius scraper unit and a buffing unit ensure a perfect finish. The high-powered motors of all the units ensure the unrestricted strength required for processing the broad product spectrum. To allow the optimum solution to be offered for every requirement, a jointing trimming unit and a

glue joint scraper unit are available for the machines. With the optional Quickmelt gluing section, optional workpiece gap optimization for even more effective production and the available separating and cleaning agents, this series is ideally equipped to cope with every conceivable requirement.

**Feed speed: 8 – 18 m/min (20 optional)**



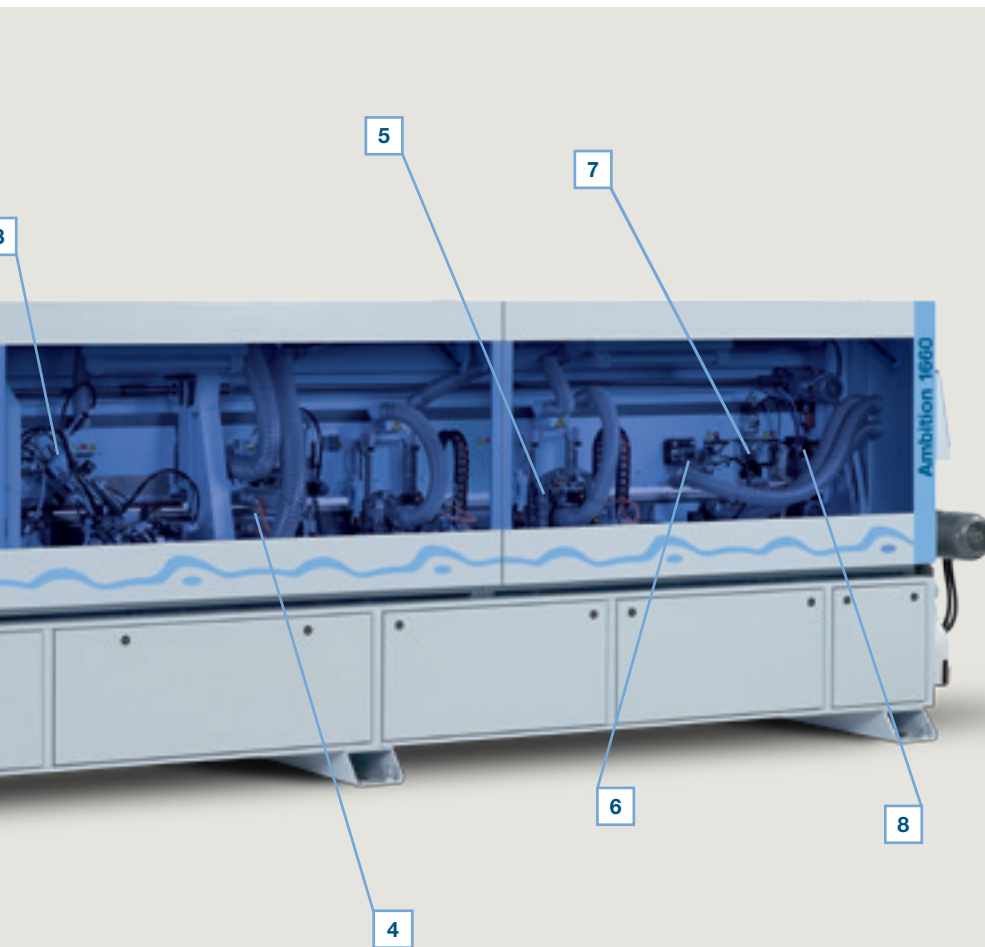

**Ambition 1660 FSC**

- 1** Jointing trimming unit
- 2** Gluing unit
- 3** Snipping unit
- 4** Rough trimming unit
- 5** Multifunctional trimming unit MF60
- 6** Profile scraper with quick-change heads
- 7** Free space glue joint scraper unit
- 8** Buffing unit

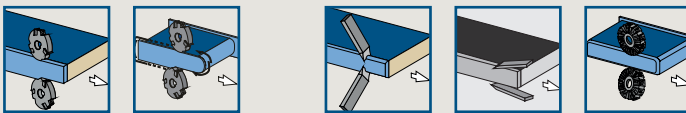

**Option**



**Ambition 1670 FSCG**

Same equipment as Ambition 1660 FSC plus a grooving unit.

**MATERIAL TYPES**

- e.g.
- 0.4 mm melamine
  - 2 mm ABS
  - Veneer (coil)
  - 12 mm solid strips
  - High gloss (option)
  - Nesting (option)

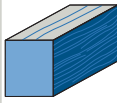
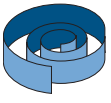
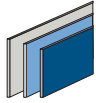
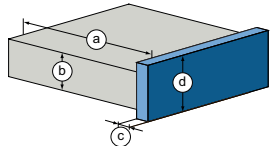
	SOLID (mm)	COILS (mm)	STRIPS (mm)
			
<b>a</b>	with b = 22: min. 70 with b = 40: min. 125		
<b>b</b>	8 – 60		
<b>c</b>	0.4 – 15	0.4 – 3	
<b>d</b>	65		
			

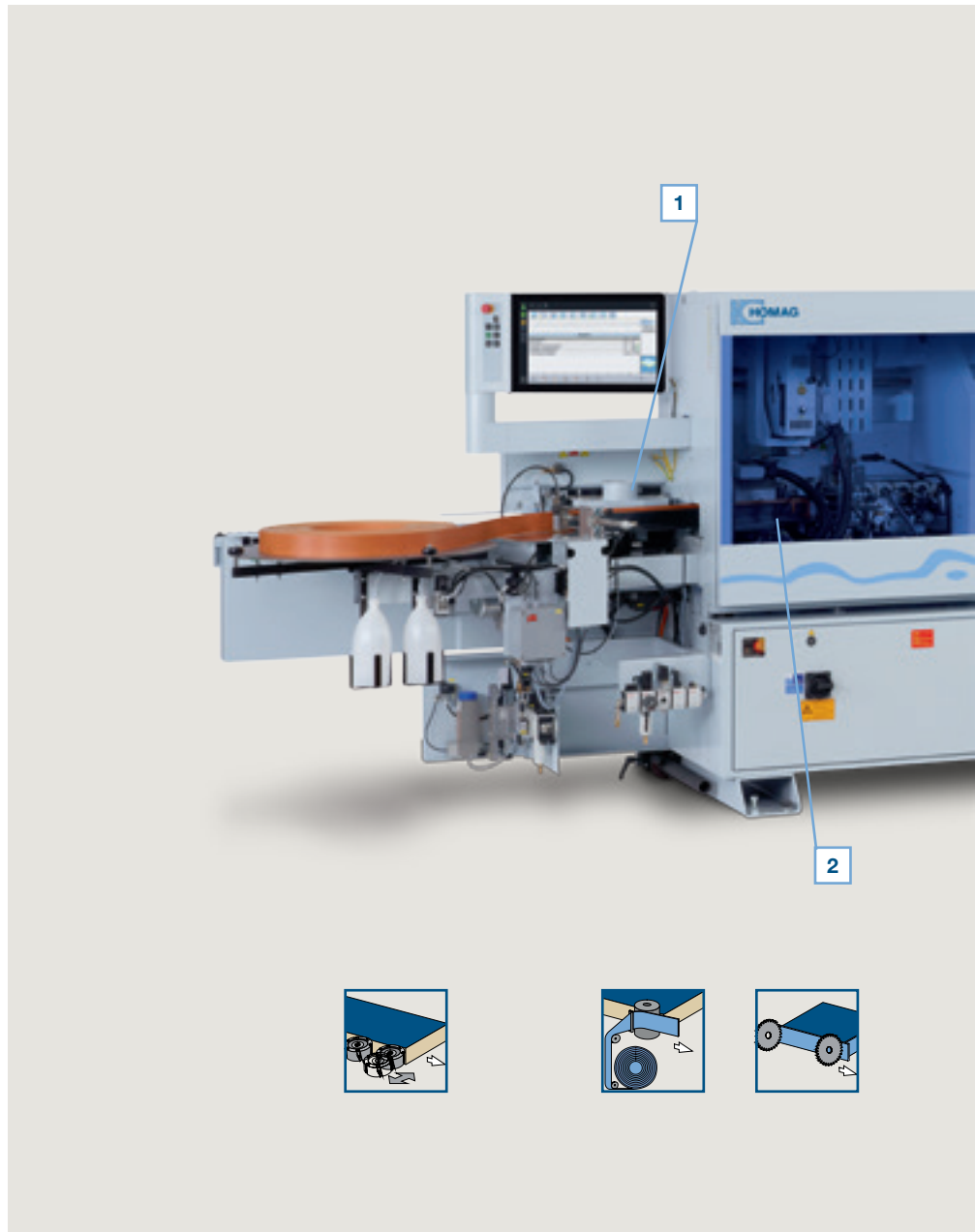

## Highflex 1650 and 1660: Precision and performance for uptown requirements

The basic machine is equipped with a Quickmelt gluing section, a 2-motor snipping unit, a trimming unit and a multifunction profile trimming unit for corner rounding and flush trimming. A radius scraper unit and a buffing unit ensure a perfect finish. The high-powered motors of all the units ensure the unrestricted strength required for processing the broad product spectrum. To allow the optimum solution to be offered for every requirement, a jointing trimming unit and a glue joint scraper unit are available for these machines as

standard. The Highflex series is characterized by its high level of automation and a comprehensive range of processing units. The high degree of flexibility enables adjustment to your specific needs and guarantees optimum edges.

**Feed speed: 8 – 18 m/min**

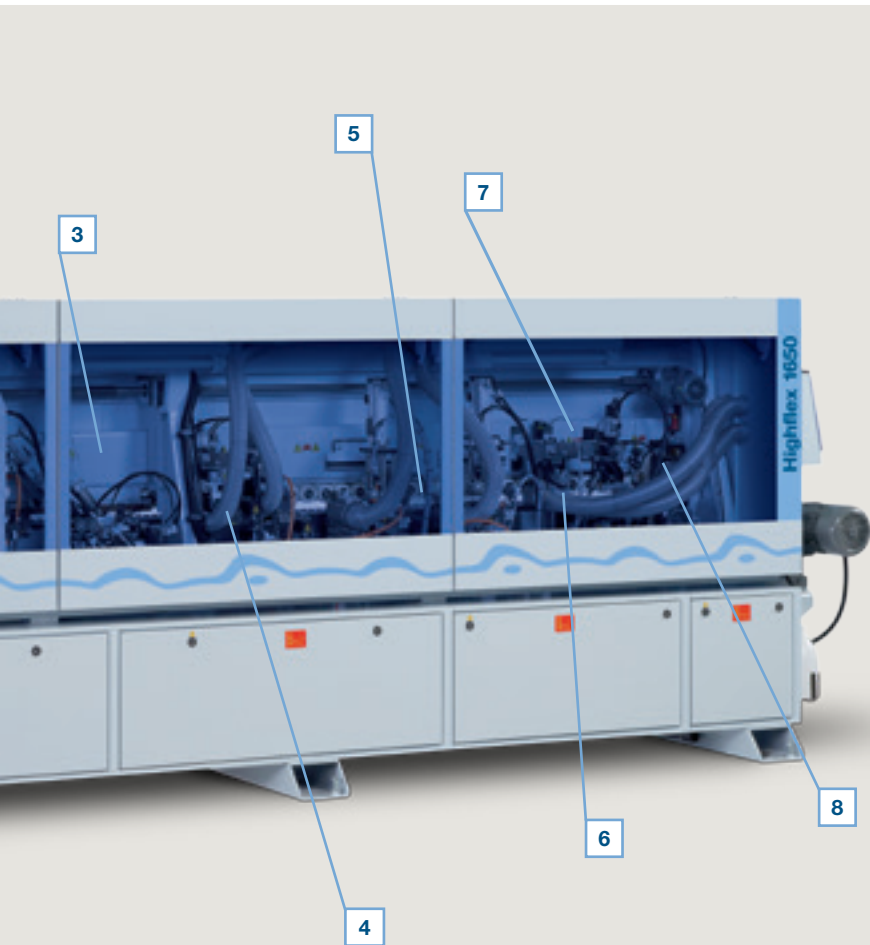

**Highflex 1650**

- 1** Jointing trimming unit
- 2** Gluing unit
- 3** Snipping unit with pneumatic adjustment chamfer/straight and pneumatic 2-point-adjustment
- 4** Rough trimming unit with pneumatic 2-point-adjustment
- 5** Multifunctional trimming unit
- 6** Profile scraper unit with quick-change heads and pneumatic adjustment
- 7** Glue joint scraper unit
- 8** Buffing unit

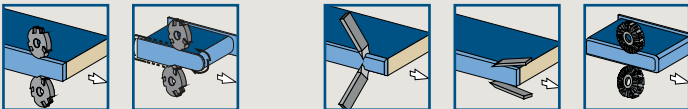

**Highflex 1660**  
Same equipment as Highflex 1650 plus a fine trimming unit.

**MATERIAL TYPES**

e.g.

- 0.4 mm melamine
- 2 mm ABS
- Veneer (coil)
- 15 mm solid strips (option)
- High gloss (option)
- Nesting (option)

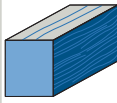
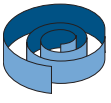
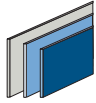
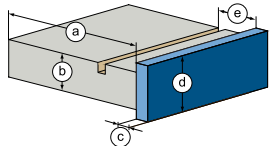
	SOLID (mm)	COILS (mm)	STRIPS (mm)
			
<b>a</b>	with b = 22: min. 70 with b = 40: min. 125		
<b>b</b>	8 – 60		
<b>c</b>	0.4 – 12	0.4 - 3.0	
<b>d</b>	65		
<b>e</b>	max. 30 (only Ambition 1880 FSCU)		
			

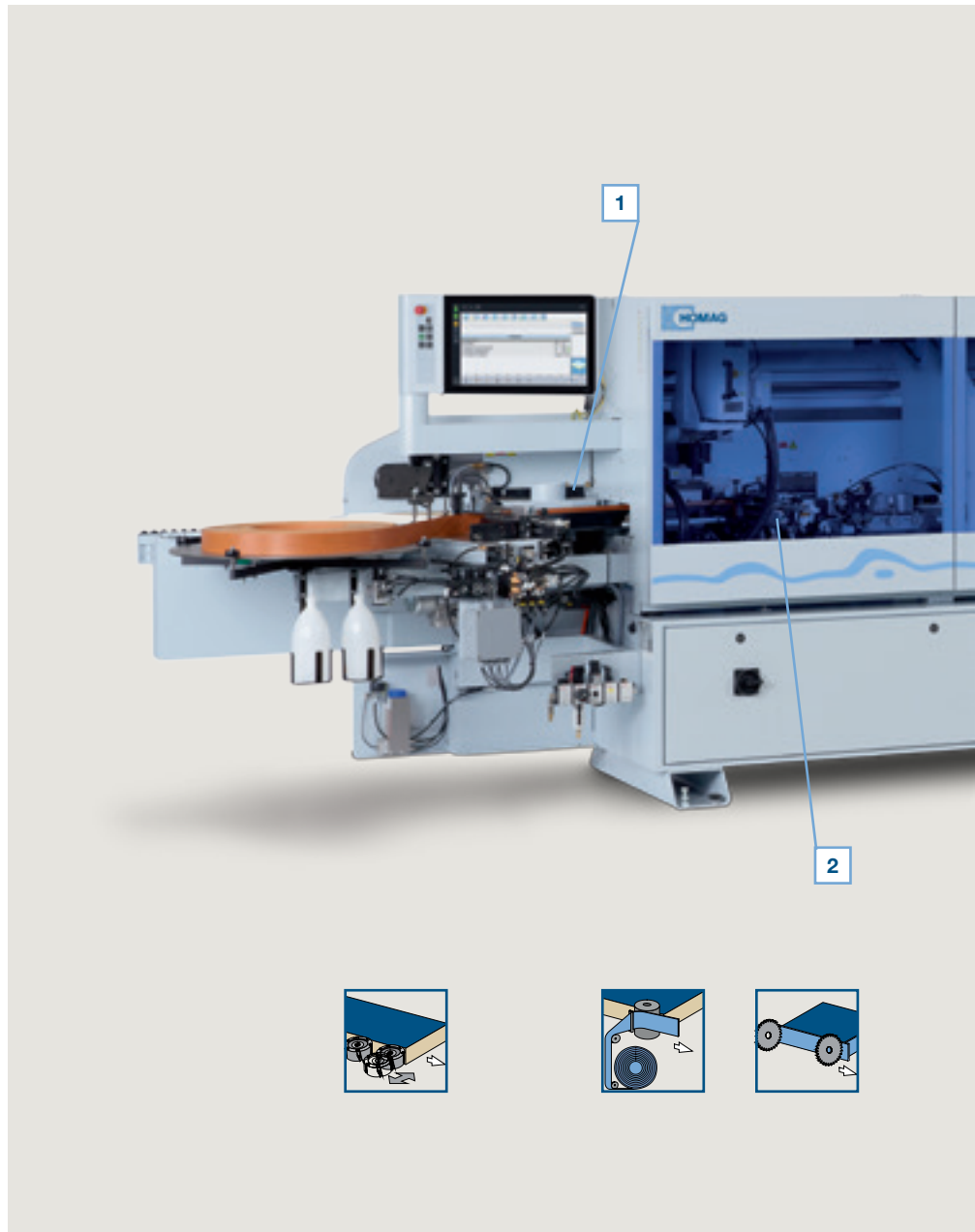

## Ambition 1870 FSC, 1880 FSCU and 1880 FGC: All-time performance without compromise

The Ambition 1800 series offers a performance spectrum otherwise only found in industrially used edge banding machines. The basic version is equipped with a jointing trimming unit, a precise gluing section, a 2-motor snipping unit, a trimming unit and a 2-motor multifunction profile trimming unit. A radius scraper unit and a buffing unit ensure a perfect finish. The use of a Quickmelt gluing section ensures a high level of availability and optimum gluing quality. Standard workpiece gap optimization, a rough trimming unit

for heavy hogging operations, a swivel-mounted grooving unit, a 4-motor profile trimming unit (Ambition 1880 FGC) and a glue joint scraper unit ensure no-compromise performance. The universal trimming unit on the Ambition 1880 FSCU guarantees high grooving and profiling output and is designed for flexible application.

**Feed speed: 8 – 20 m/min**

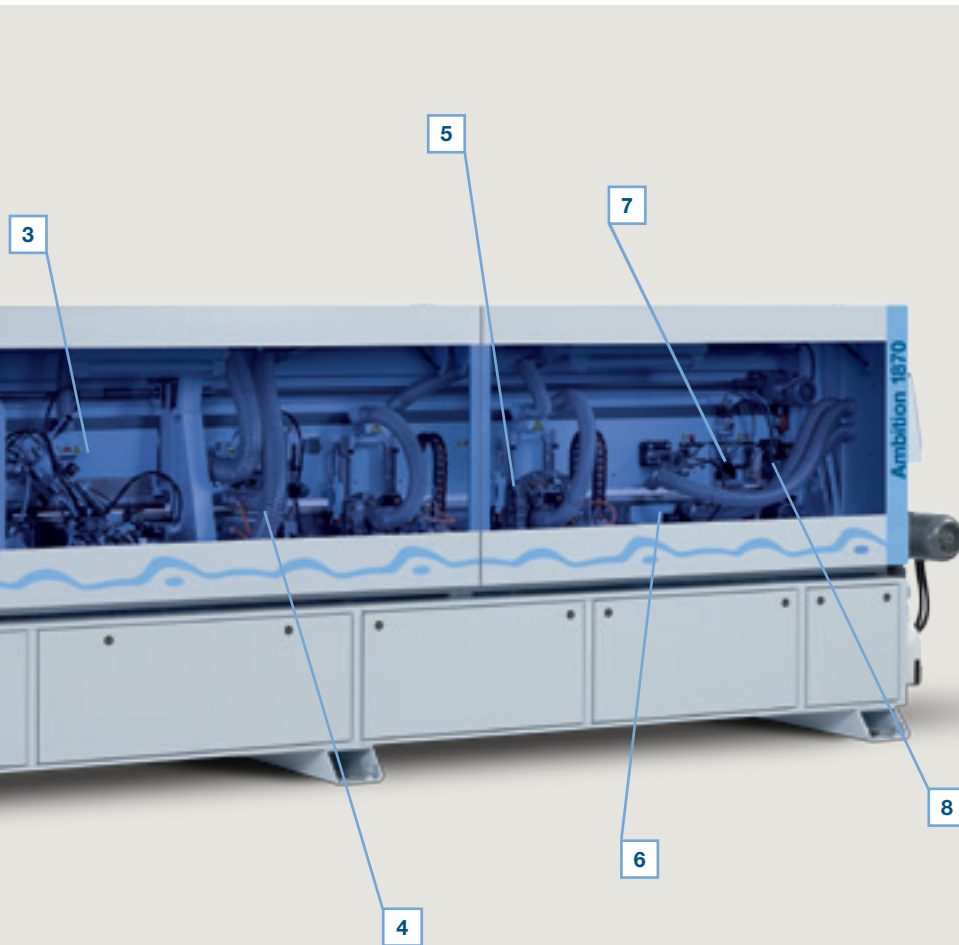

**Ambition 1870 FSC**

- 1** Jointing trimming unit
- 2** Gluing unit
- 3** Snipping unit
- 4** Rough trimming unit
- 5** Multifunctional trimming unit MF60
- 6** Profile scraper unit with quick-change heads
- 7** Free space glue joint scraper unit
- 8** Buffing unit

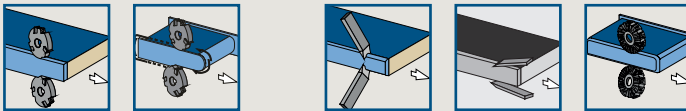

**Option**



**Ambition 1880 FSCU**

Same equipment as Ambition 1870 FSC plus a universal trimming unit.

**MATERIAL TYPES**

- e.g.
- 0.4 mm melamine
  - 2 mm ABS
  - Veneer (coil)
  - 20 mm solid strips (option)
  - High gloss (option)
  - Nesting (option)

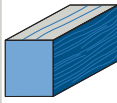
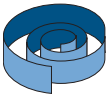
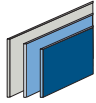
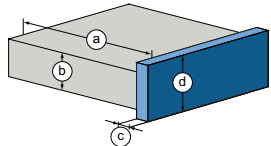
	SOLID (mm)	COILS (mm)	STRIPS (mm)
			
<b>a</b>	with b = 22: min. 70 with b = 40: min. 125		
<b>b</b>	8 – 60		
<b>c</b>	0.4 – 15	0.4 – 3	
<b>d</b>	65		
			

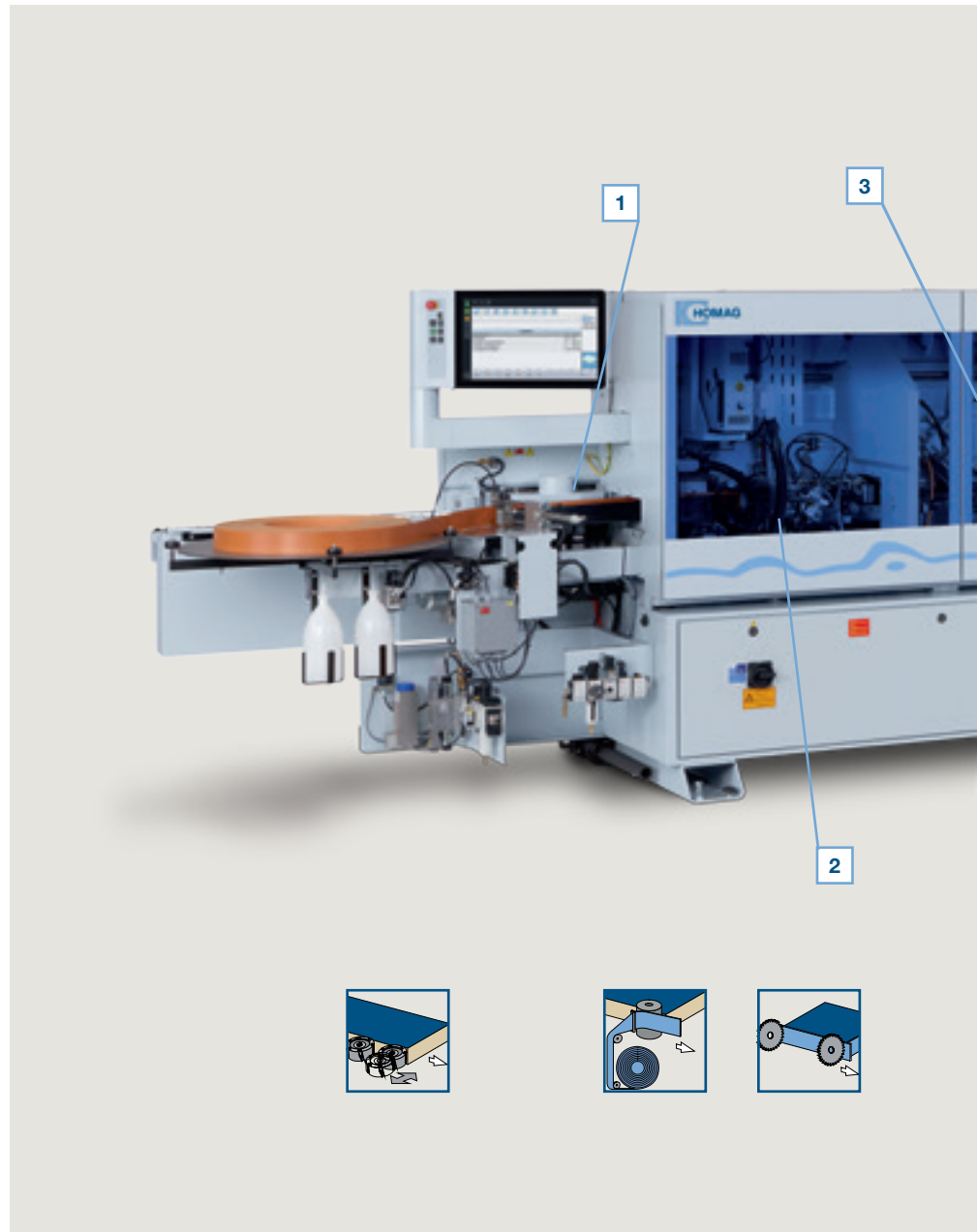

## Highflex 1870 and 1880: Setting standards in performance and quality

The basic machine is equipped with a Quickmelt gluing section, a 2-motor snipping unit, a trimming unit and a profile trimming unit for corner rounding and flush trimming. A radius scraper unit and a buffing unit ensure a perfect finish. The high-powered motors of all the units ensure the unrestricted strength required for processing the broad product spectrum. To allow the optimum solution to be offered for every requirement, a jointing trimming unit and a glue joint scraper unit are available for these machines as

standard. The Highflex series is characterized by its high level of automation and a comprehensive range of processing units. The high degree of flexibility enables adjustment to your specific needs and guarantees optimum edges.

**Feed speed: 8 – 20 m/min**

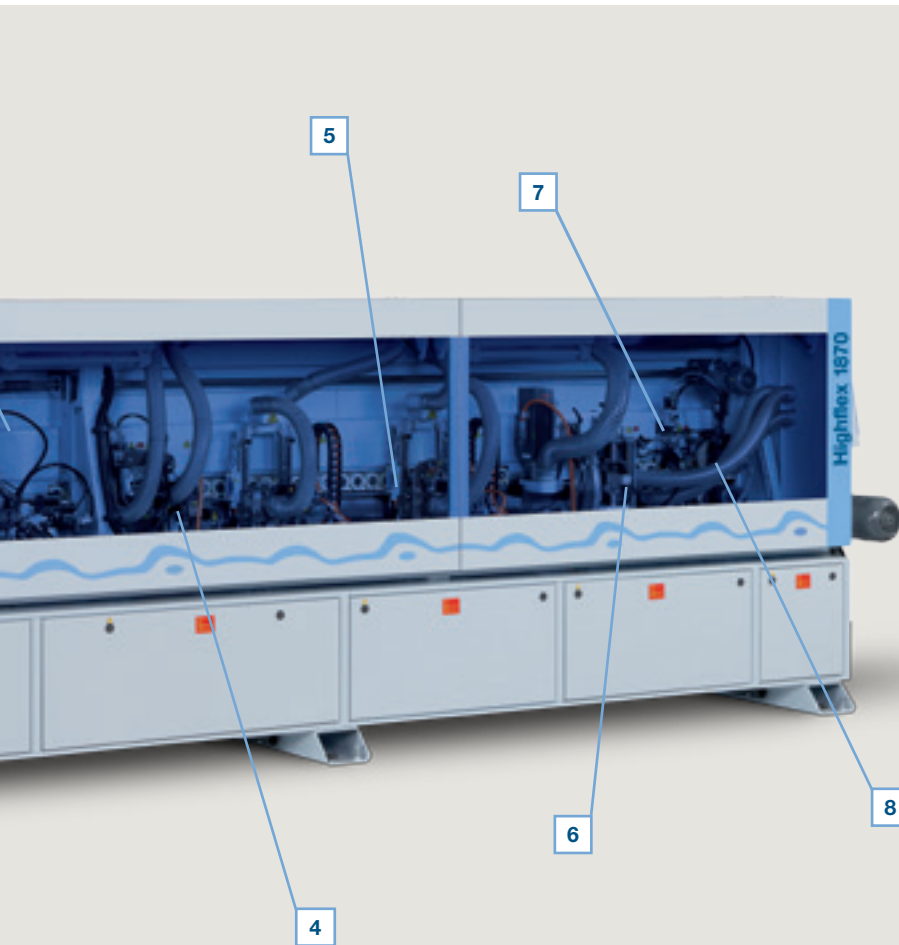

**Highflex 1870**

- 1** Jointing trimming unit
- 2** Gluing unit
- 3** Snipping unit with pneumatic adjustment chamfer/straight and pneumatic 2-point-adjustment
- 4** Rough trimming unit with pneumatic 2-point-adjustment
- 5** Multifunctional trimming unit MF60
- 6** Profile scraper unit with quick-change heads and pneumatic adjustment
- 7** Glue joint scraper unit
- 8** Buffing unit

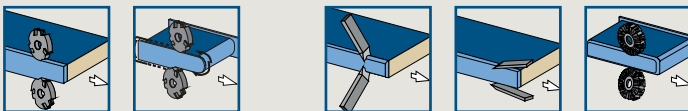

**Highflex 1880**

Same equipment as Highflex 1870. The machine is equipped with a 4-motor profile trimming unit plus a fine trimming unit.

**MATERIAL TYPES**

- e.g.
- 0.4 mm melamine
  - 2 mm ABS
  - Veneer (coil)
  - 20 mm solid strips (option)
  - High gloss (option)
  - Nesting (option)

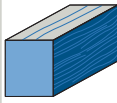
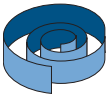
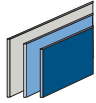
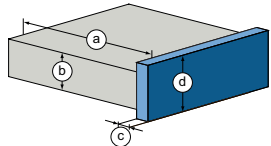
	SOLID (mm)	COILS (mm)	STRIPS (mm)
			
<b>a</b>	with b = 22: min. 70 with b = 40: min. 125		
<b>b</b>	8 – 60		
<b>c</b>	0.4 – 12	0.4 – 3	
<b>d</b>	65		
			

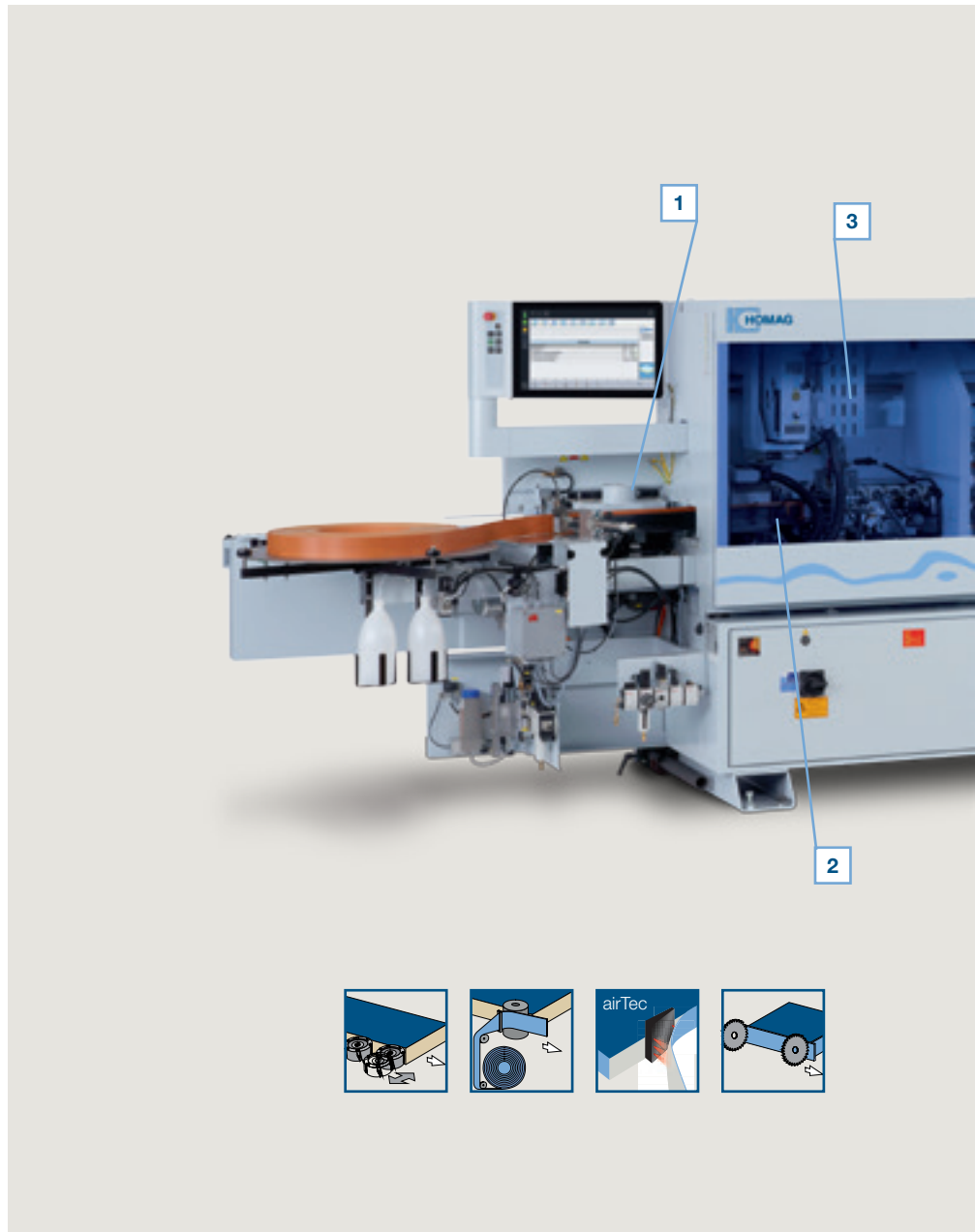

## Ambition 1650 airTec and 1860 airTec: With the new generation of zero joint technology

The Ambition 1650 airTec and Ambition 1860 airTec are the ideal machines for joineries with high-end requirements. They provide the optimum solution wherever an optimum zero joint or other edge processing operations are required. The nerve center of these machines is the gluing section, which alongside the airTec activation unit also acts as a dual solution, guaranteeing outstanding flexibility. Alongside the magazine, the Ambition 1650 airTec and Ambition 1860 airTec are equipped with a jointing trimming unit, a 2-motor

snipping unit, a trimming unit and a profile trimming unit. A radius scraper unit, a glue joint scraper unit and a buffing unit ensure a perfect finish. The airTec models are characterized by their high level of automation and a comprehensive range of processing units.

**Feed speed: 8 – 20 m/min**



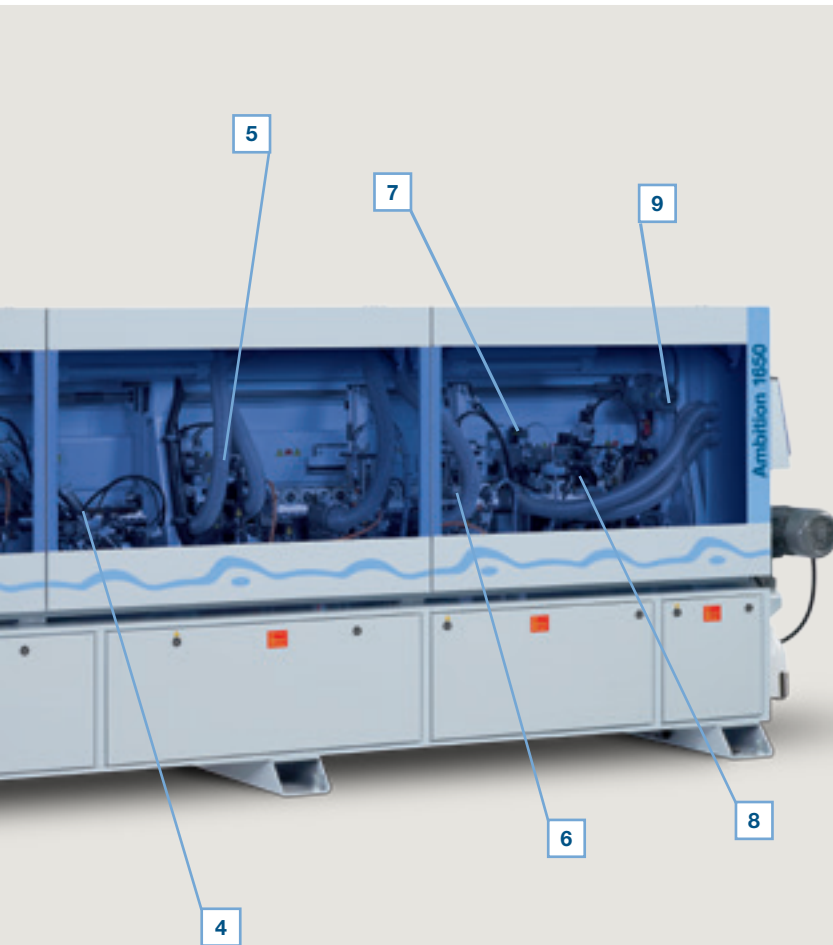

**Ambition 1650 airTec**

- 1** Jointing trimming unit
- 2** Gluing unit
- 3** airTec activation unit
- 4** Snipping unit with pneumatic adjustment chamfer/straight
- 5** Trimming unit with pneumatic 2-point-adjustment and program adjustment lateral sensing
- 6** Profile trimming unit
- 7** Profile scraper unit with quick-change heads and pneumatic adjustment
- 8** Glue joint scraper unit
- 9** Buffing unit

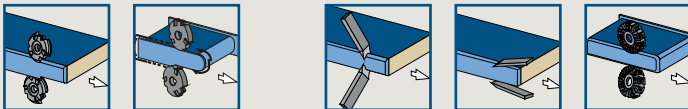

**Ambition 1860 airTec**

Same equipment as Ambition 1650 airTec. The machine is equipped alternatively with a 4-motor profile trimming unit for higher feed speed.

**MATERIAL TYPES**

- e.g.
- 0.4 mm melamine
  - 2 mm ABS
  - Veneer (coil)
  - 12 mm solid strips (option)
  - High gloss (option)
  - Nesting (option)

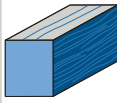
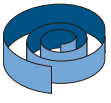
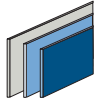
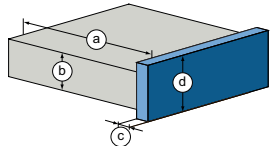
	SOLID (mm)	COILS (mm)	STRIPS (mm)
			
<b>a</b>	with b = 22: min. 70 with b = 40: min. 125		
<b>b</b>	8 – 60		
<b>c</b>	0.4 – 12	0.4 – 3	
<b>d</b>	65		
			



## KDF 650 edition and KDF 860 edition: The high-performance compact class

Even in their basic equipment configuration, the edition models offer a high level of automation and simple processing of several radii as standard. The basic versions are equipped with a jointing trimming unit, a precise Quickmelt gluing section, a 2-motor snipping unit, a multi-stage trimming unit and a profile trimming unit. A multi-stage scraper unit, a glue joint scraper unit and a buffing unit ensure a perfect finish. The edition models are characterized

by their high level of automation. The multi-stage trimming unit and multi-stage scraper unit provide the optimum radius and consequently the very best results for frequently changing applications.

**Feed speed: 8 – 20 m/min**

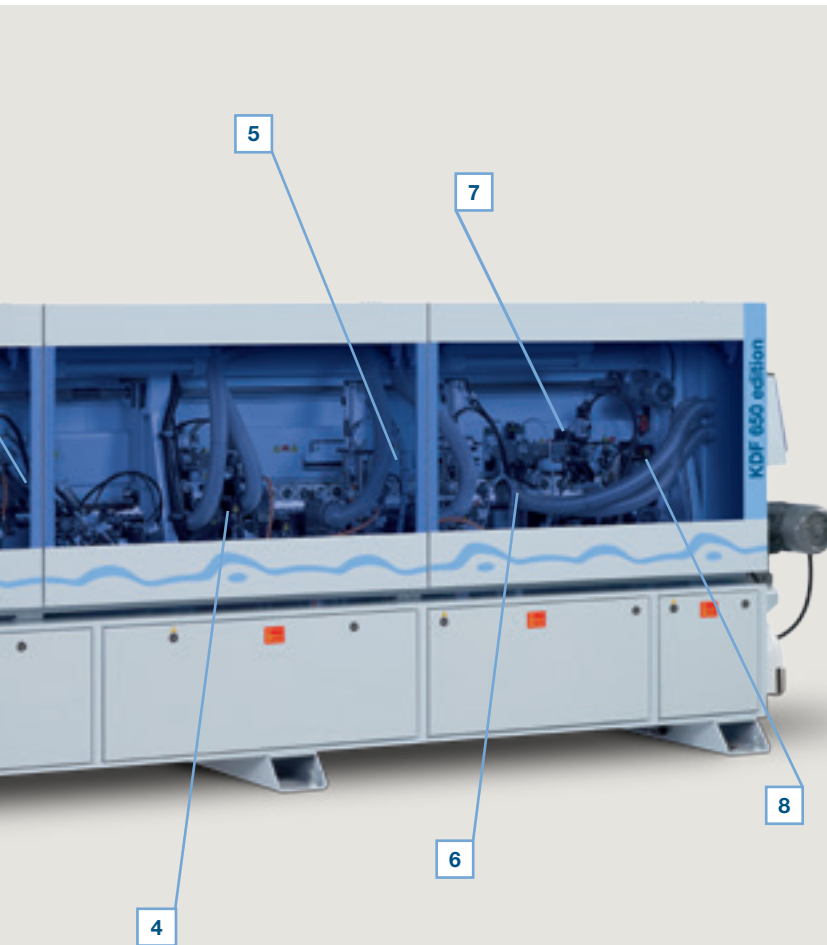

**KDF 650 edition**

- 1** Jointing trimming unit
- 2** Gluing unit
- 3** Snipping unit with pneumatic adjustment chamfer/straight and pneumatic 2-point-adjustment
- 4** Multi-stage trimming unit MS40 with pneumatic 2-point-adjustment
- 5** Profile trimming unit
- 6** Multi-stage scraper unit MZ40
- 7** Glue joint scraper unit
- 8** Buffing unit

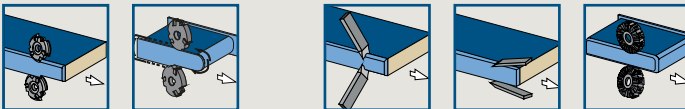

**KDF 860 edition**

Same equipment as KDF 650 edition plus top pressure belt as a standard.

**MATERIAL TYPES**

- e.g.
- 0.4 mm melamine
  - 2 mm ABS
  - Veneer (coil)
  - 12 mm solid strips
  - High gloss (option)
  - Nesting (option)

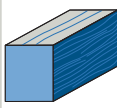
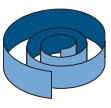
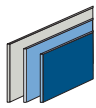
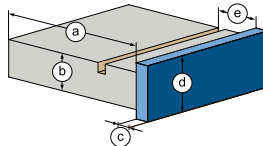
	SOLID (mm)	COILS (mm)	STRIPS (mm)
			
<b>a</b>	with b = 22: min. 60 with b = 40: min. 105		
<b>b</b>	8 – 60		
<b>c</b>	0.6 – 20 (option)	0.3 – 3.0	0.3 – 1.0 (option)
<b>d</b>	12 – 65		
<b>e</b>	max. 25 (only Ambition 2280)		
			

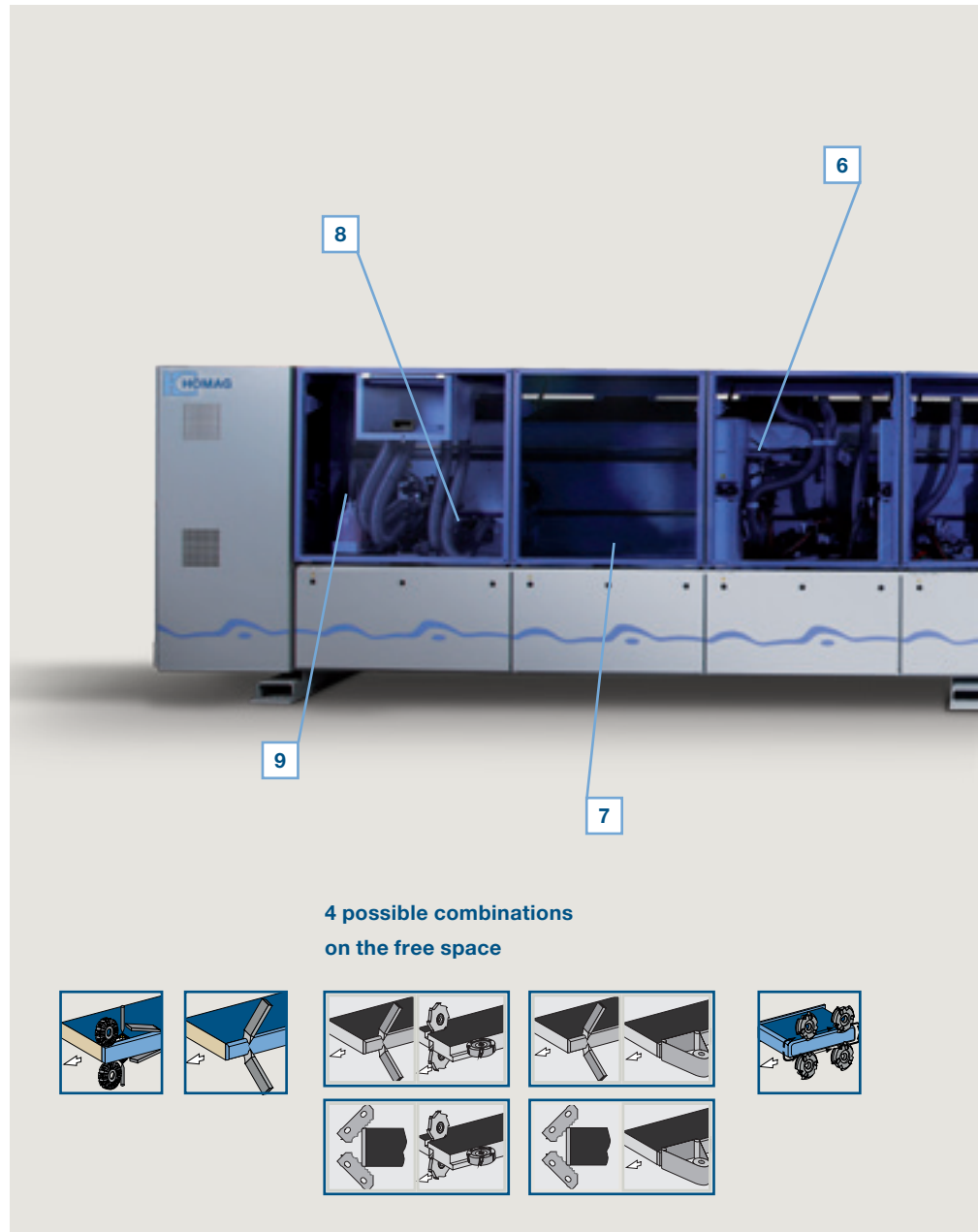

## Ambition 2270 and 2280: For variable edge gluing

Ambition models 2270 and 2280 can be used for edge gluing, precise snipping and finish processing, including rounding of face sides. The finishing unit at the outfeed removes any possible glue residues and lends grip to your edges. PU can additionally be used if required. Using the 4-motor profile trimming unit, even veneer edges can be

rounded without splintering. With a feed speed of up to 20 m/min, the machine provides optimum productivity for woodworking shops. The Ambition 2280 also features a free space for additional units.

**Feed speed: 16 – 20 m/min**

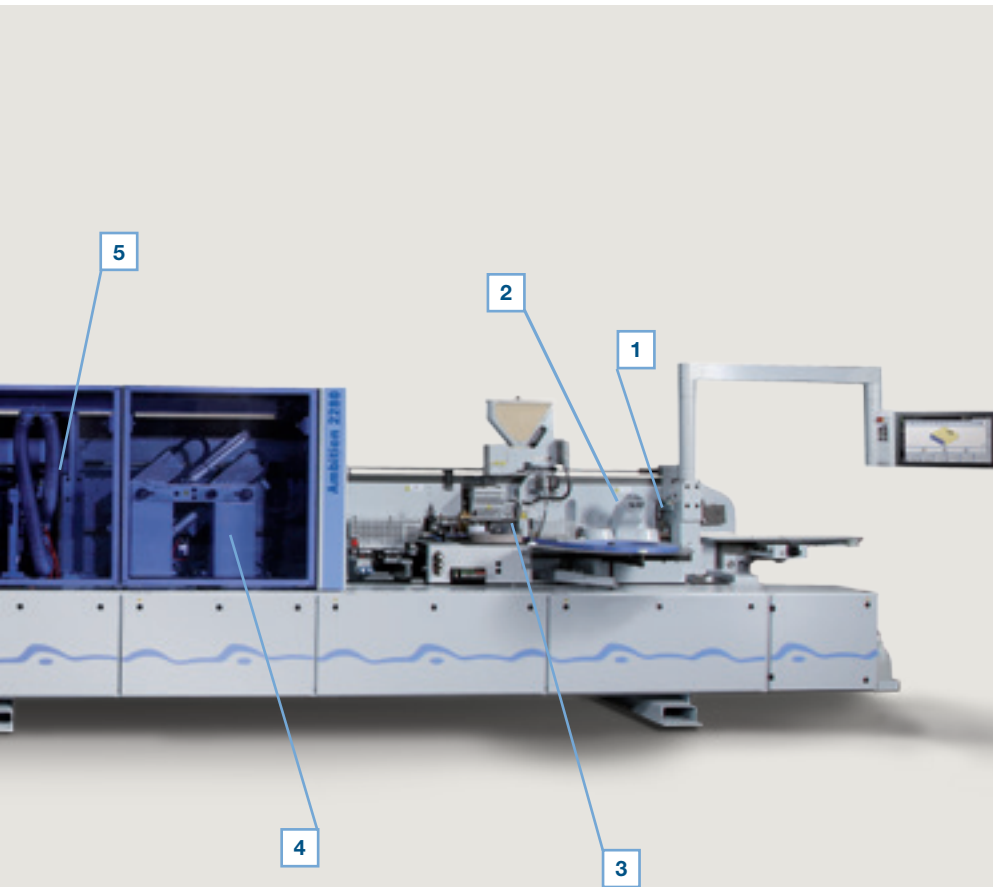

**Ambition 2280**

- 1** Separating agent spraying unit
- 2** Jointing trimming unit
- 3** Gluing unit with 2 coils
- 4** Snipping unit HL81
- 5** Rough trimming unit BF10
- 6** Profile trimming unit FF30
- 7** Free space for 2 additional units:  
standard trimming unit SF21  
or belt sanding unit KS10 and  
automatic profile scraper unit  
MN21 (instead of PN10)
- 8** Profile scraper unit PN10
- 9** Finishing unit FA21

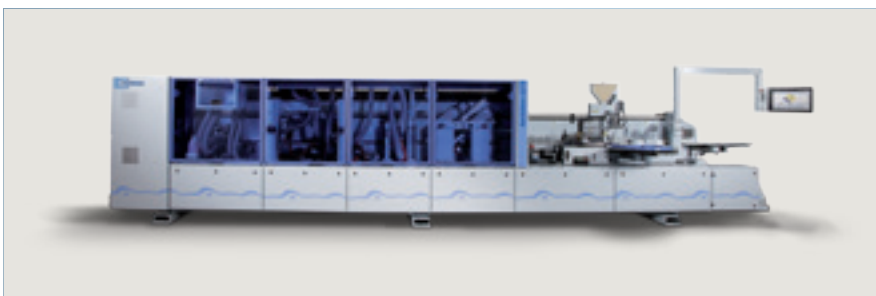
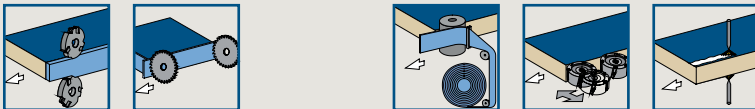

**Ambition 2270**

Same equipment as Ambition 2280, but **without free space**.

**MATERIAL TYPES**

- e.g.
- 0.4 mm melamine
  - 2 mm PVC
  - Veneer (coil)
  - 20 mm solid strips (option)
  - High gloss (option)
  - Nesting (option)

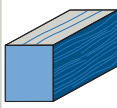
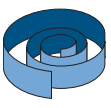
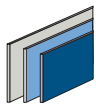
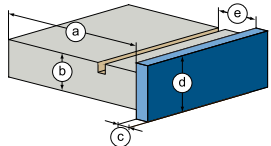
	SOLID (mm)	COILS (mm)	STRIPS (mm)
			
<b>a</b>	with b = 22: min. 60 with b = 40: min. 105		
<b>b</b>	8 – 60		
<b>c</b>	0.6 – 20 (option)	0.3 – 3.0	0.3 – 1.0 (option)
<b>d</b>	12 – 65		
<b>e</b>	max. 25 (only Ambition 2284)		
			

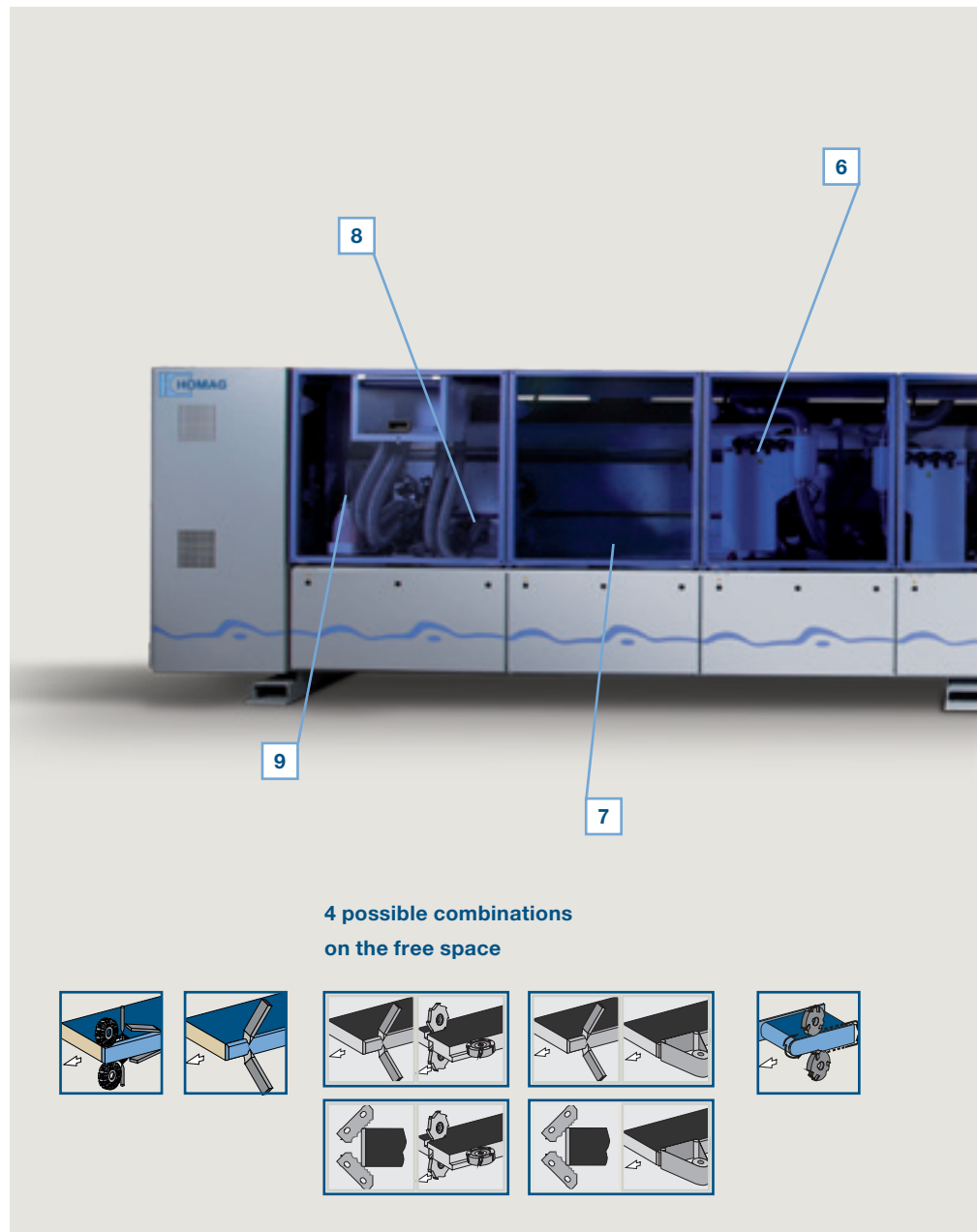

## Ambition 2274 and 2284: Impressive technology

Ambition models 2274 and 2284 can be used for gluing edges, precise snipping and finish processing, including rounding the face sides. Facility for using PU is also optionally available. The processing heads at the profile trimming unit and profile scraper unit can be rapidly exchanged for work with different profiles. No-compromise production. And with

an unbelievable cost-to-performance ratio. Ambition 2284 also comes with a free space for additional units.

**Feed speed: 16 – 20 m/min**

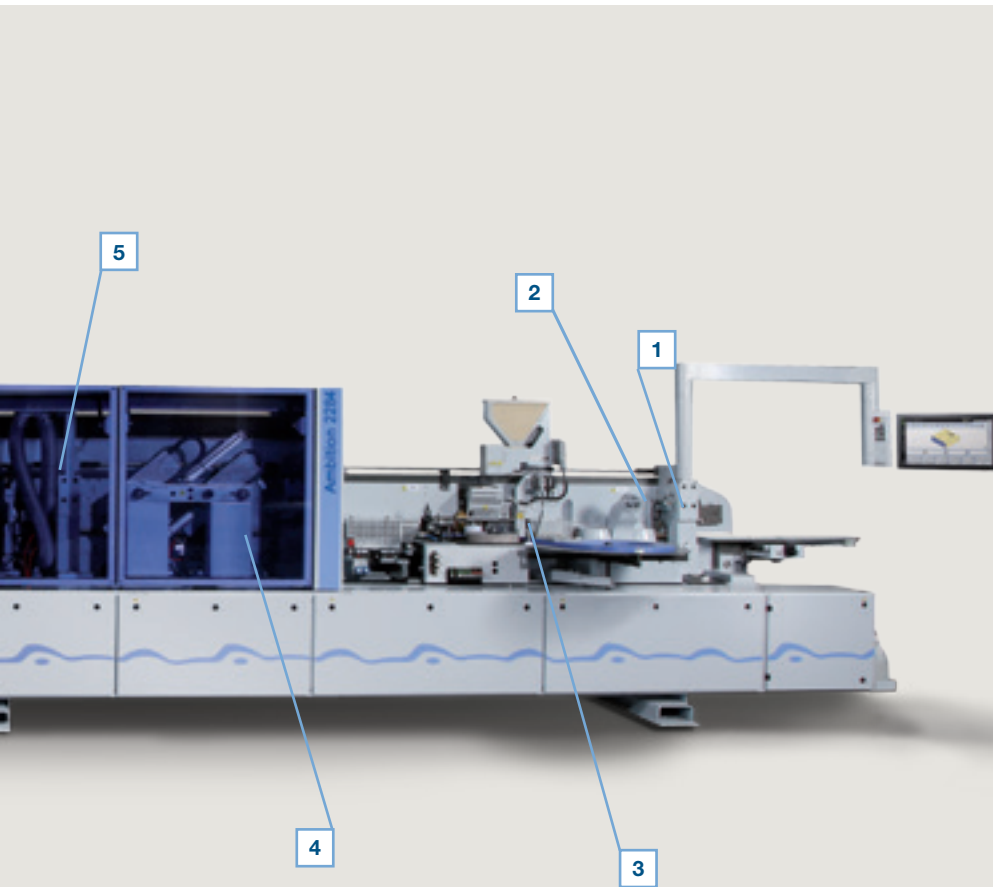

**Ambition 2284**

- 1** Separating agent spraying unit
- 2** Jointing trimming unit
- 3** Gluing unit with 2 coils
- 4** Snipping unit HL81
- 5** Rough trimming unit BF10
- 6** Profile trimming unit FK11
- 7** Free space for 2 additional units:  
standard trimming unit SF21  
or belt sanding unit KS10 and  
automatic profile scraper unit  
MN21 (instead of PN10)
- 8** Profile scraper unit PN10
- 9** Finishing unit FA21

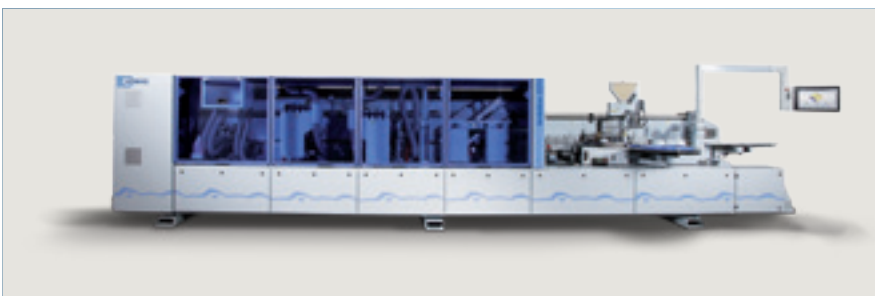
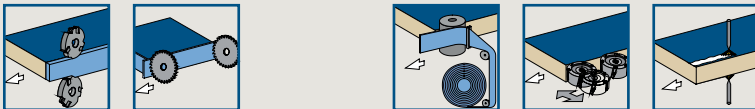

**Ambition 2274**  
Same equipment as Ambition 2284, but **without free space**.

**MATERIAL TYPES**

- e.g.
- 0.4 mm melamine
  - 2 mm PVC
  - 20 mm solid strips  
(option)
  - High gloss (option)
  - Nesting (option)

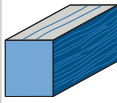
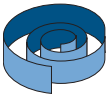
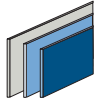
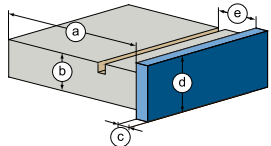
	SOLID (mm)	COILS (mm)	STRIPS (mm)
			
<b>a</b>	with b = 22: min. 60 with b = 40: min. 105		
<b>b</b>	8 – 60		
<b>c</b>	0.6 – 20 (option)	0.3 – 3.0	0.3 – 1.0 (option)
<b>d</b>	12 – 65		
<b>e</b>	max. 25 (only Ambition 2480)		
			

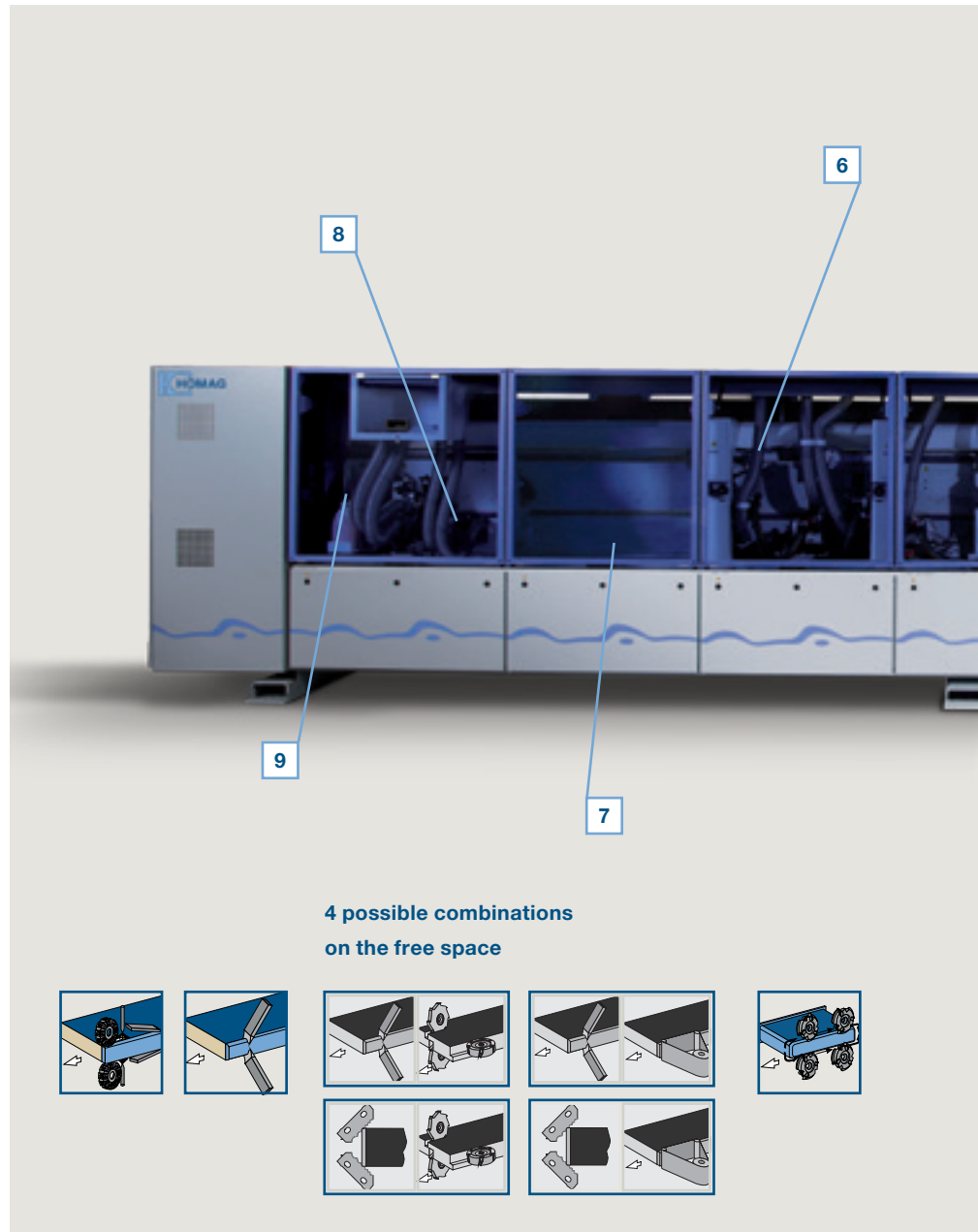

## Ambition 2470 and 2480: Flexible edge processing

Ambition 2470 and Ambition 2480 can be used for gluing edges, precise snipping and finish processing, including rounding the face sides. PU can also be used if required. Even veneer edges are rounded using the 4-motor profile trimming unit without splintering. The different equipment packages on offer permit adaptation of the machines for a

wide range of different requirements. With feed speed of up to 25 m/min, producers with higher output targets can tailor their productivity to changing demands. Ambition 2480 additionally offers a free space for additional units.

**Feed speed: 16 – 25 m/min**



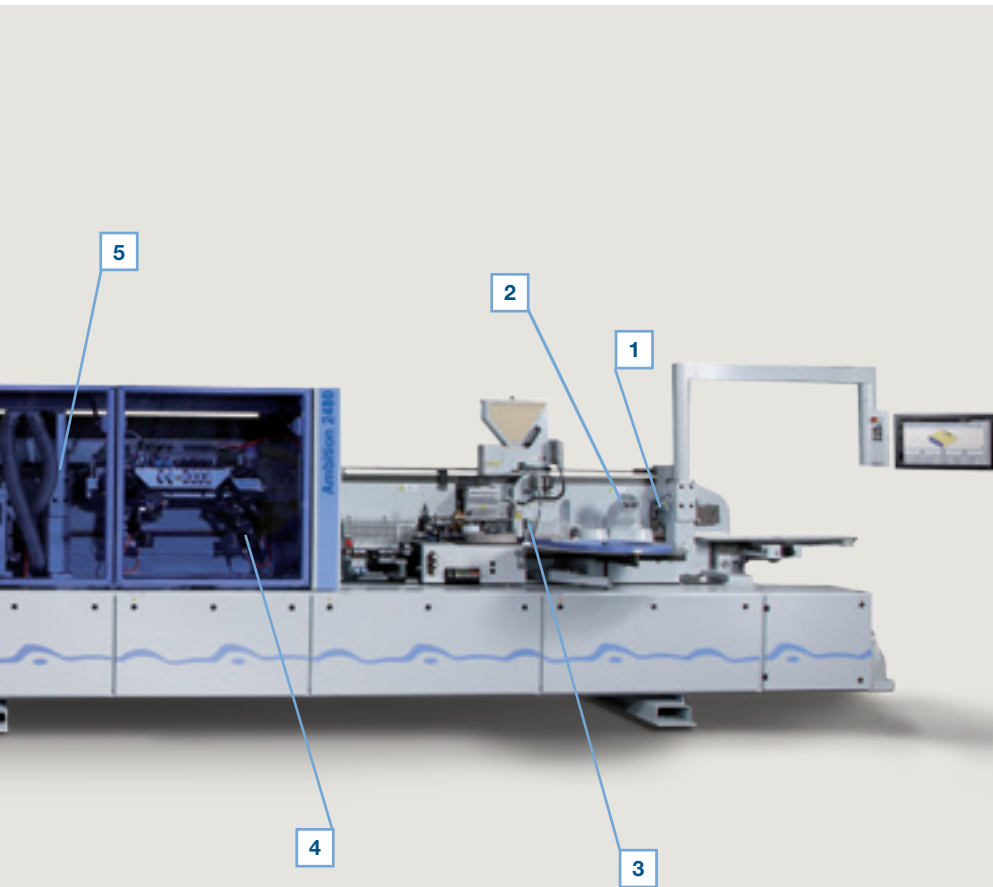

**Ambition 2480**

- 1** Separating agent spraying unit
- 2** Jointing trimming unit
- 3** Gluing unit with 2 coils
- 4** Snipping unit PK25
- 5** Rough trimming unit BF10
- 6** Profile trimming unit FF32
- 7** Free space for 2 additional units:  
standard trimming unit SF21  
or belt sanding unit KS10 and  
automatic profile scraper unit  
MN21 (instead of PN10)
- 8** Profile scraper unit PN10
- 9** Finishing unit FA21

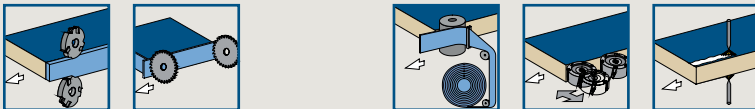

**Ambition 2470**

Same equipment as Ambition 2480, but **without free space**.

**MATERIAL TYPES**

- e.g.
- 0.4 mm melamine
  - 2 mm PVC
  - Veneer (coil)
  - 20 mm solid strips (option)
  - High gloss (option)
  - Nesting (option)

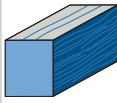
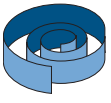
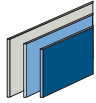
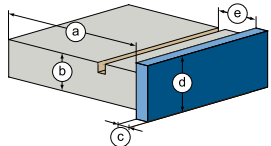
	SOLID (mm)	COILS (mm)	STRIPS (mm)
			
<b>a</b>	with b = 22: min. 60 with b = 40: min. 105		
<b>b</b>	8 – 60		
<b>c</b>	0.6 – 20 (option)	0.3 – 3.0	0.3 – 1.0 (option)
<b>d</b>	12 – 65		
<b>e</b>	max. 25 (only Ambition 2484)		
			

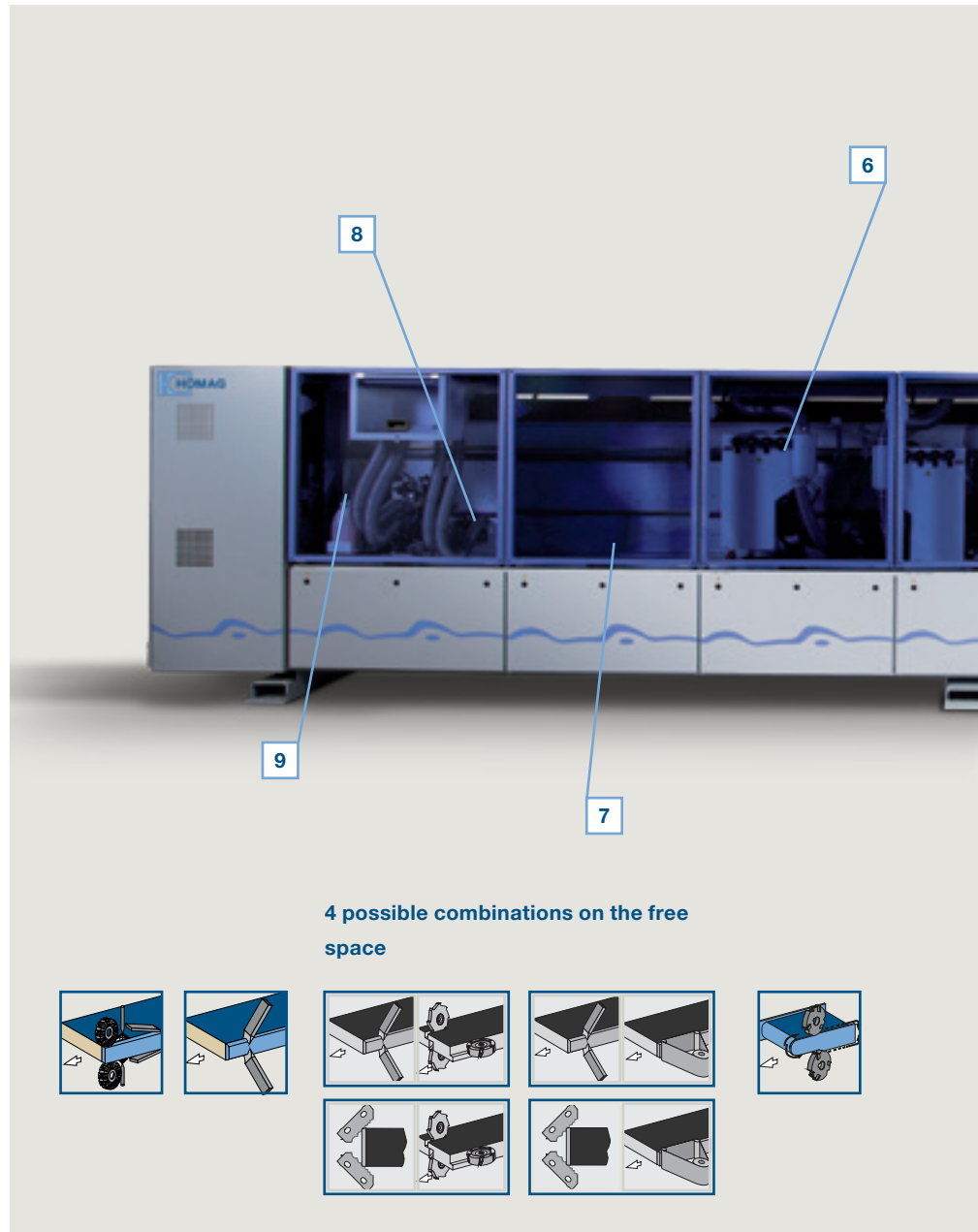

## Ambition 2474 and 2484: With patented technology

These Ambition models can be used for edge gluing, precise snipping and finish processing, including rounding of face sides. The finishing unit at the outfeed removes any possible glue residues and lends grip to your edges. PU can additionally be used if required. A patented solution at the profile trimming unit permits the fast, simple changeover of profiles. With a feed speed of up to 25 m/min, the machine

provides need-driven productivity for producers with a higher performance requirement. No need to compromise. With its additional free space, Ambition 2484 offers even greater flexibility for mounting a grooving unit.

**Feed speed: 16 – 25 m/min**

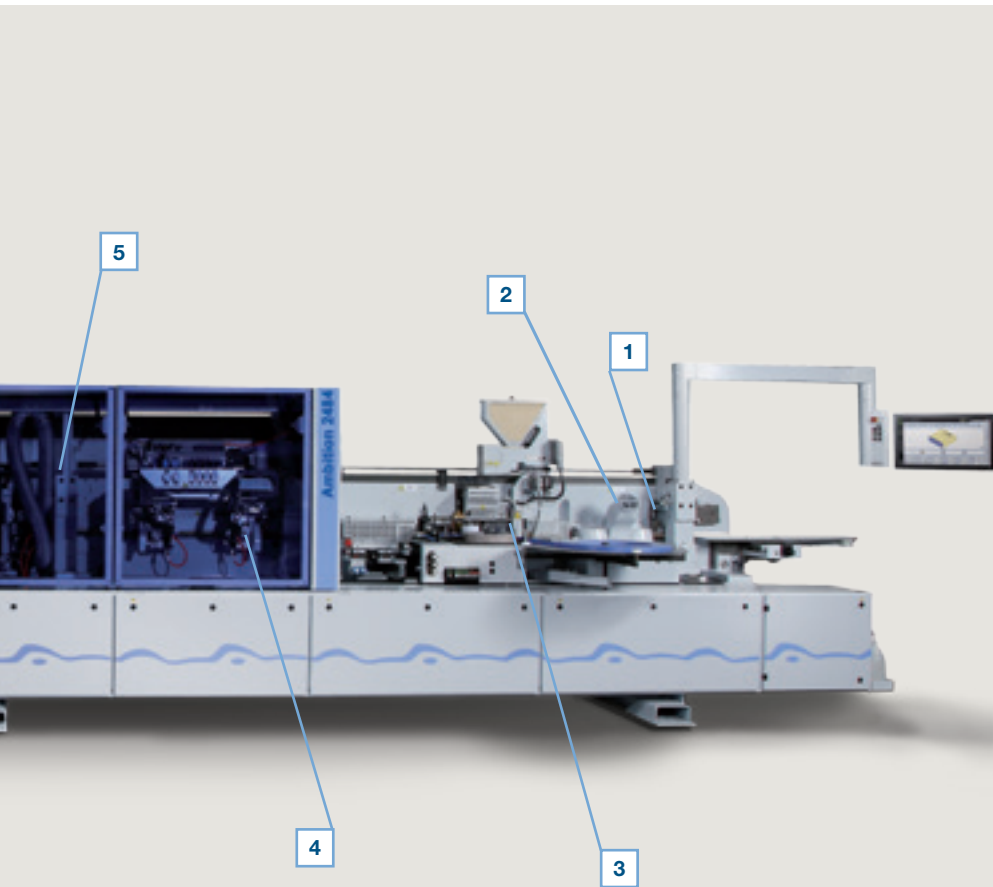

**Ambition 2484**

- 1** Separating agent spraying unit
- 2** Jointing trimming unit
- 3** Gluing unit with 2 coils
- 4** Snipping unit PK25
- 5** Rough trimming unit BF10
- 6** Profile trimming unit FK11
- 7** Free space for 2 additional units:  
standard trimming unit SF21  
or belt sanding unit KS10 and  
automatic profile scraper unit  
MN21 (instead of PN10)
- 8** Profile scraper unit PN10
- 9** Finishing unit FA21

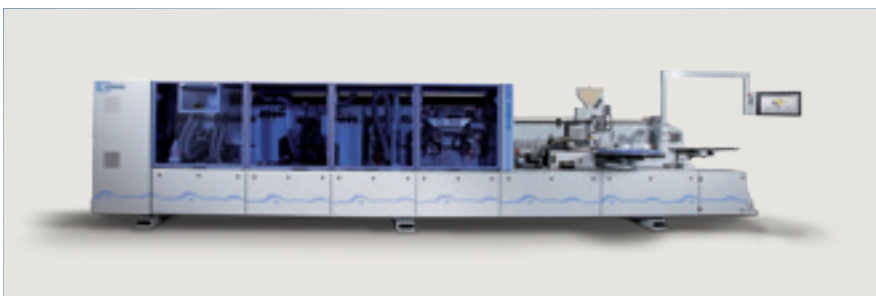
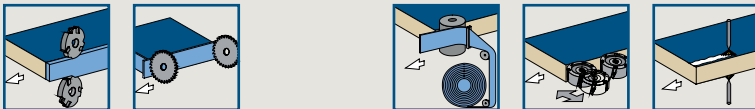

**Ambition 2474**  
Same equipment as Ambition 2484, but **without free space**.

**MATERIAL TYPES**

- e.g.
- 0.4 mm melamine
  - 2 mm PVC
  - 20 mm solid strips  
(option)
  - High gloss (option)
  - Nesting (option)

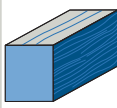
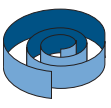
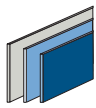
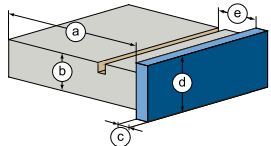
	SOLID (mm)	COILS (mm)	STRIPS (mm)
			
<b>a</b>	with b = 22: min. 60 with b = 40: min. 105		
<b>b</b>	8 – 60		
<b>c</b>	0.6 – 20 (option)	0.3 – 3.0	0.3 – 1.0 (option)
<b>d</b>	12 – 65		
<b>e</b>	max. 25 (only Ambition 2492)		
			

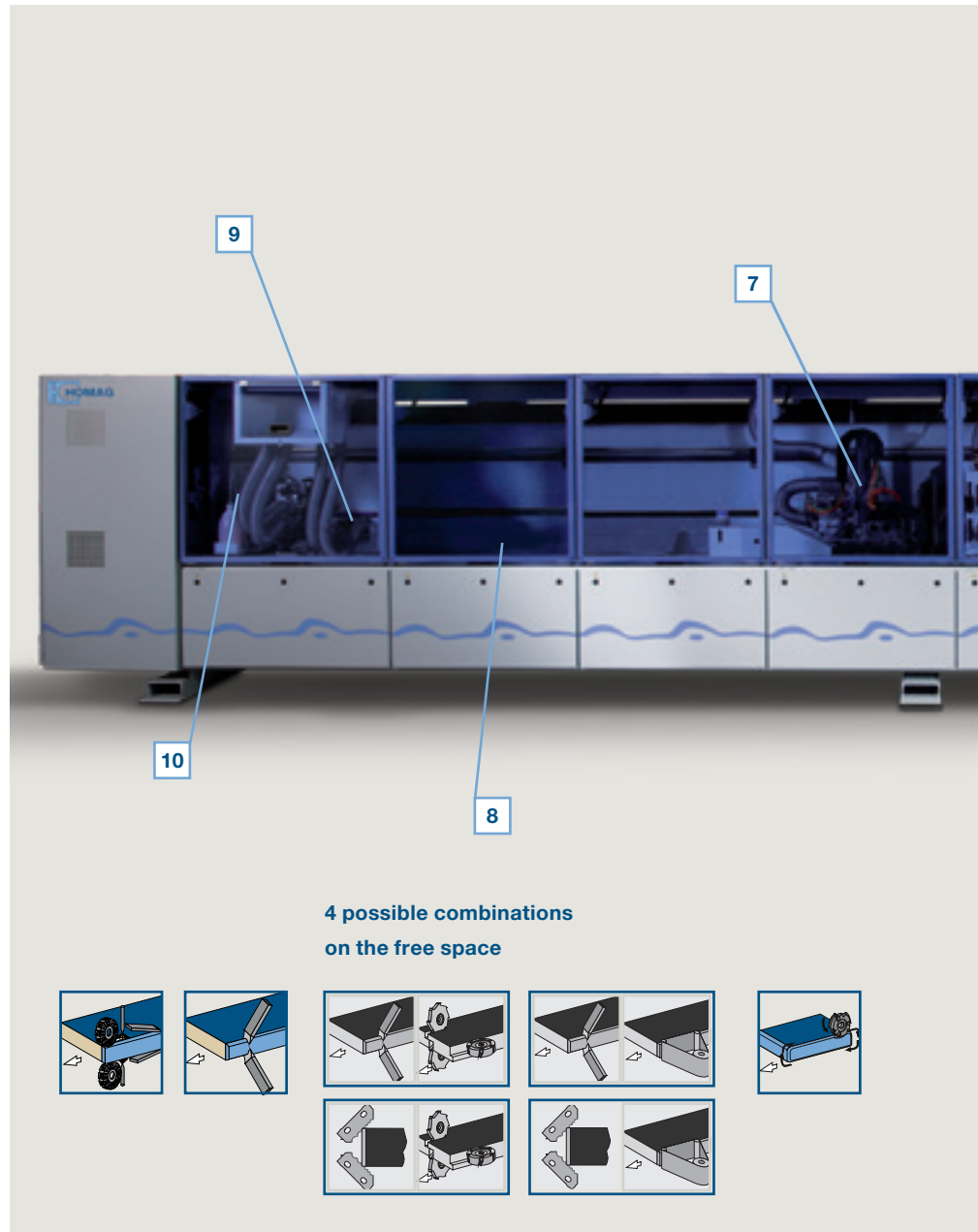

## Ambition 2482 and 2492: Economy for high aspirations

Ambition 2482 and Ambition 2492 can be used for gluing edges, precise snipping and finish processing, including rounding the face sides. The profile trimming unit with linear servo drive offers a premium standard of processing quality. These ambition models offer scope for simple automatic changeover between two profiles, such as a 2 mm and 3 mm radius. With feed speed of up to 25 m/min, producers with

higher output requirements can tailor their productivity to changing demands. The Ambition 2492 offers an additional free space for even greater flexibility.

**Feed speed: 16 – 25 m/min**

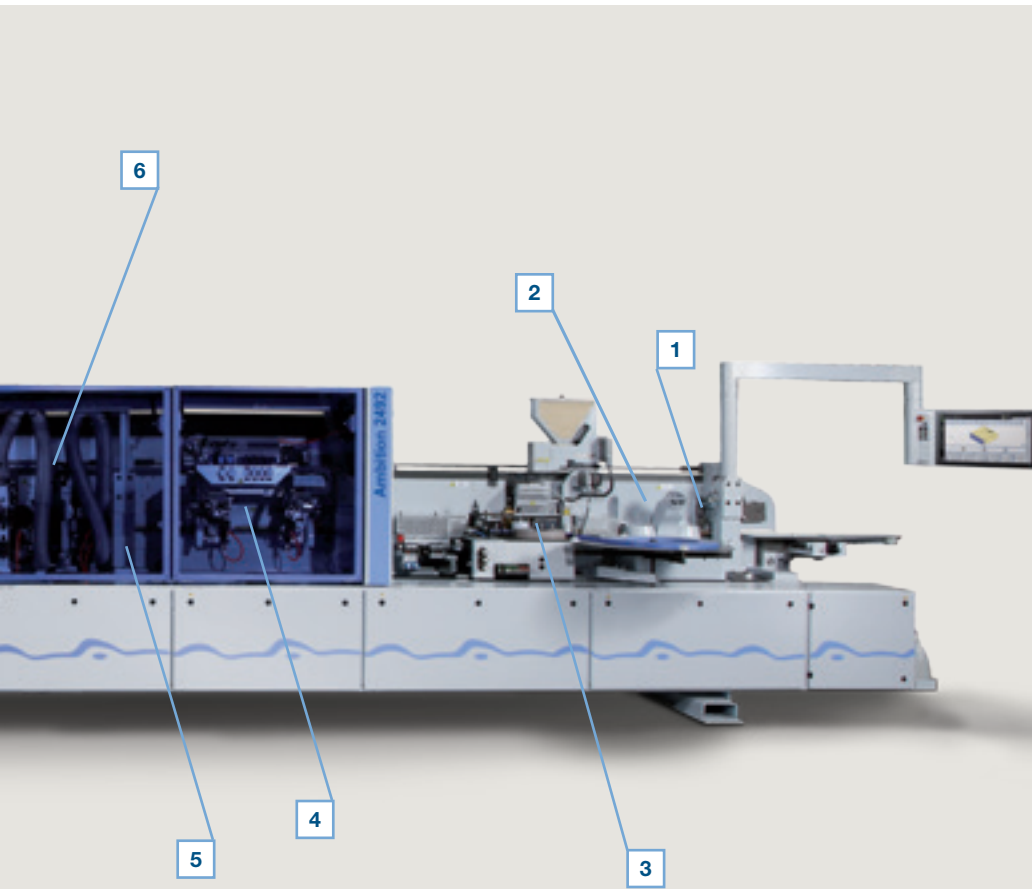

**Ambition 2492**

- 1** Separating agent spraying unit
- 2** Jointing trimming unit
- 3** Gluing unit with 2 coils
- 4** Snipping unit PK25
- 5** Rough trimming unit BF10
- 6** Chamfer/radius trimming unit PF20
- 7** Profile trimming unit FK30
- 8** Free space for 2 additional units:  
standard trimming unit SF21  
or belt sanding unit KS10 and  
automatic profile scraper unit  
MN21 (instead of PN10)
- 9** Profile scraper unit PN10
- 10** Finishing unit FA21

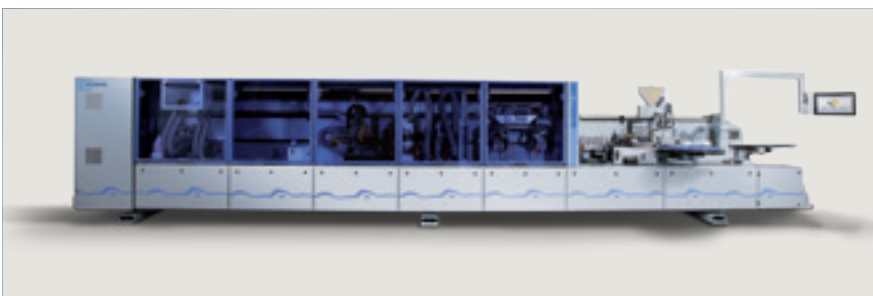
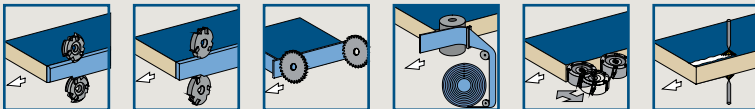

**Ambition 2482**

Same equipment as Ambition 2492, but **without free space**.

**MATERIAL TYPES**

- e.g.
- 0.4 mm melamine
  - 2 mm PVC
  - 20 mm solid strips (option)
  - High gloss (option)
  - Nesting (option)

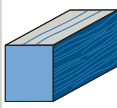
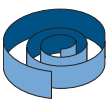
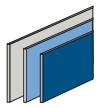
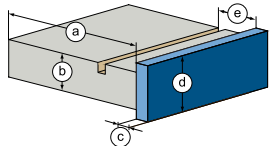
	SOLID (mm)	COILS (mm)	STRIPS (mm)
			
<b>a</b>	with b = 22: min. 60 with b = 40: min. 105		
<b>b</b>	8 – 60		
<b>c</b>	0.6 – 20 (option)	0.3 – 3.0	0.3 – 1.0 (option)
<b>d</b>	12 – 65		
<b>e</b>	max. 25 (only Ambition 2670)		
			

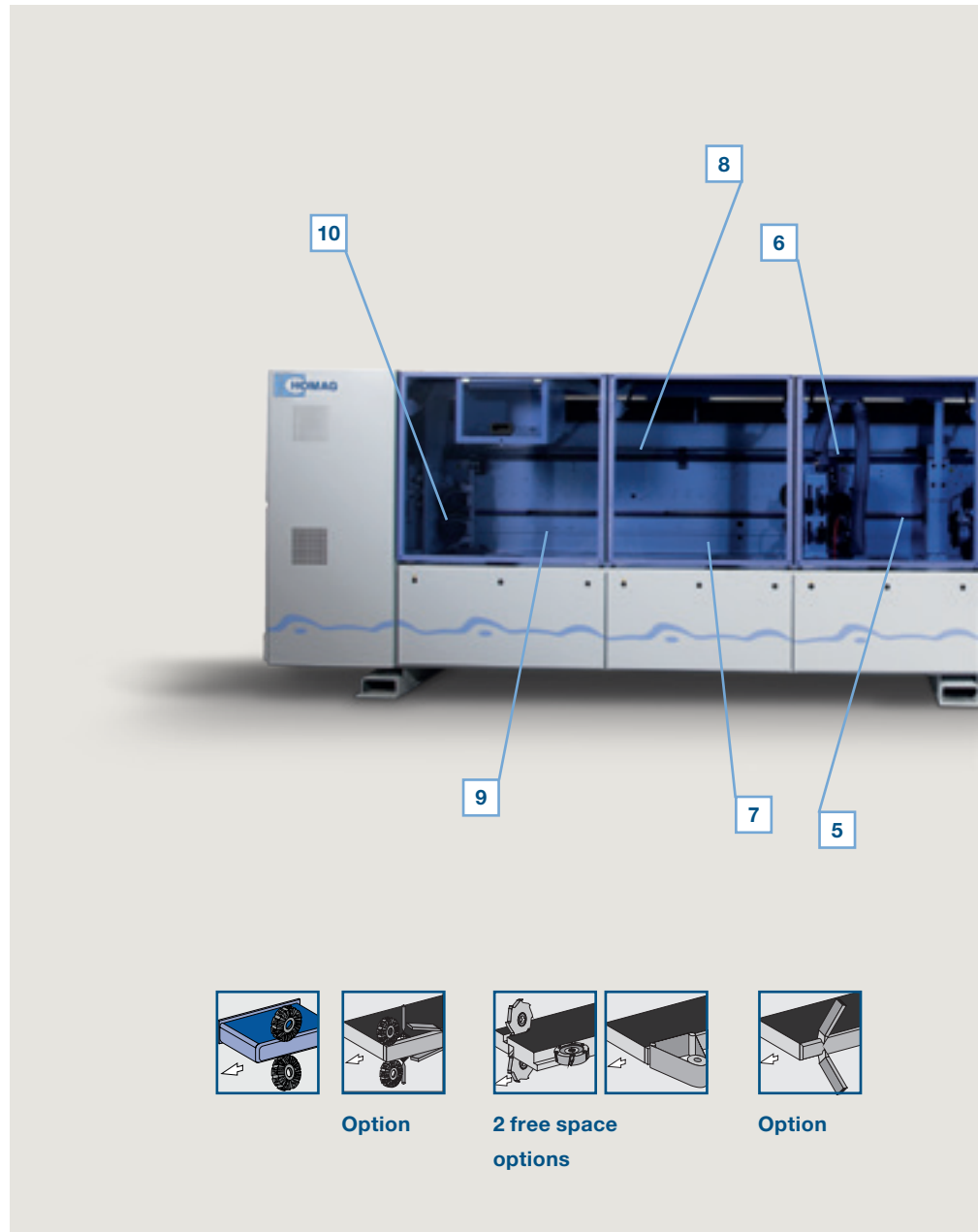

## Ambition 2660 and 2670: More than just trimming

These Ambition models can be used for edge gluing, precise snipping and finish processing. The buffing unit at the outfeed imparts a perfect grip to your edges. A maximum feed speed of 28 m/min increases your productivity. Ambition 2670 comes with an additional free space, e.g. for

mounting a grooving unit. Equipped with a solid wood package and grooving unit, rebates on solid wood edges can be processed.

**Feed speed: 16 – 28 m/min**

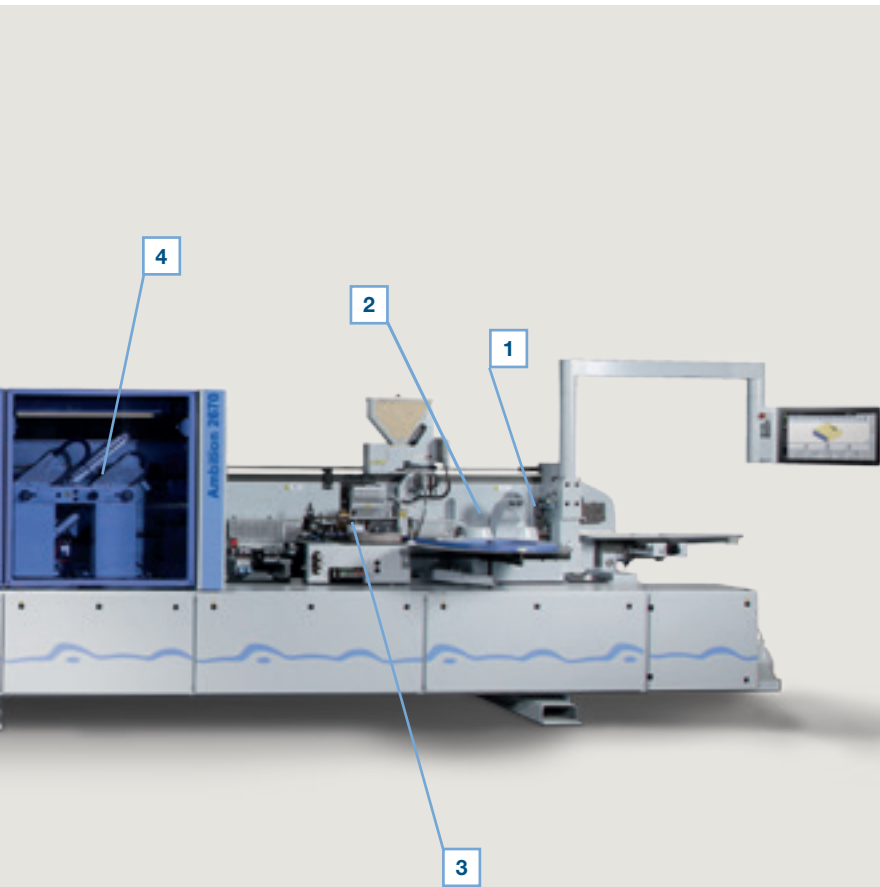

**Ambition 2670**

- 1** Separating agent spraying unit
- 2** Jointing trimming unit
- 3** Gluing unit with 2 coils
- 4** Snipping unit HL81
- 5** Free space rough trimming unit BF10
- 6** Chamfer/radius trimming unit PF20
- 7** Free space profile scraper unit PN10
- 8** Free space for 2 additional units: standard trimming unit SF21 or belt sanding unit KS10
- 9** Free space finishing unit FA20 Basic
- 10** Buffing unit

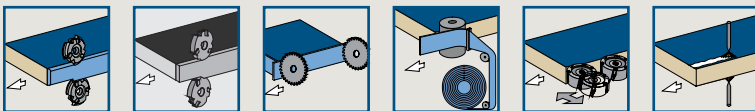

Option

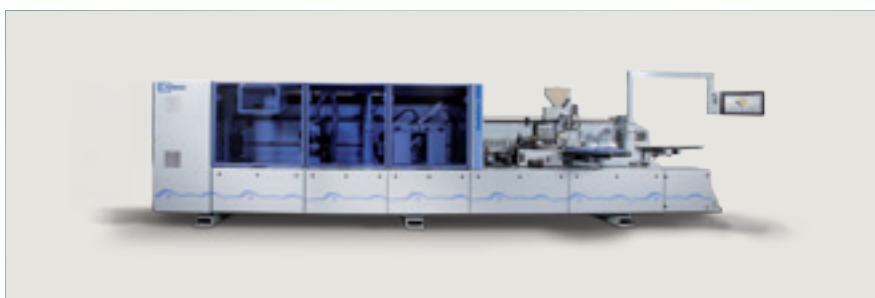



**Ambition 2660**

Same equipment as Ambition 2670, but **without free space**.

**MATERIAL TYPES**

e.g.

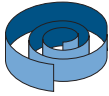
- 0.4 mm melamine
- 2 mm PVC
- Veneer (coil)
- 20 mm solid strips (option)

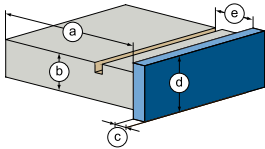
	<b>COILS</b> (mm)	<b>STRIPS</b> (mm)
		
<b>a</b>	with b = 22: min. 60 with b = 40: min. 105	
<b>b</b>	8 – 60	
<b>c</b>	0.3 - 3.0	0.3 – 1.0 (option)
<b>d</b>	12 – 65	
<b>e</b>	max. 25	
		

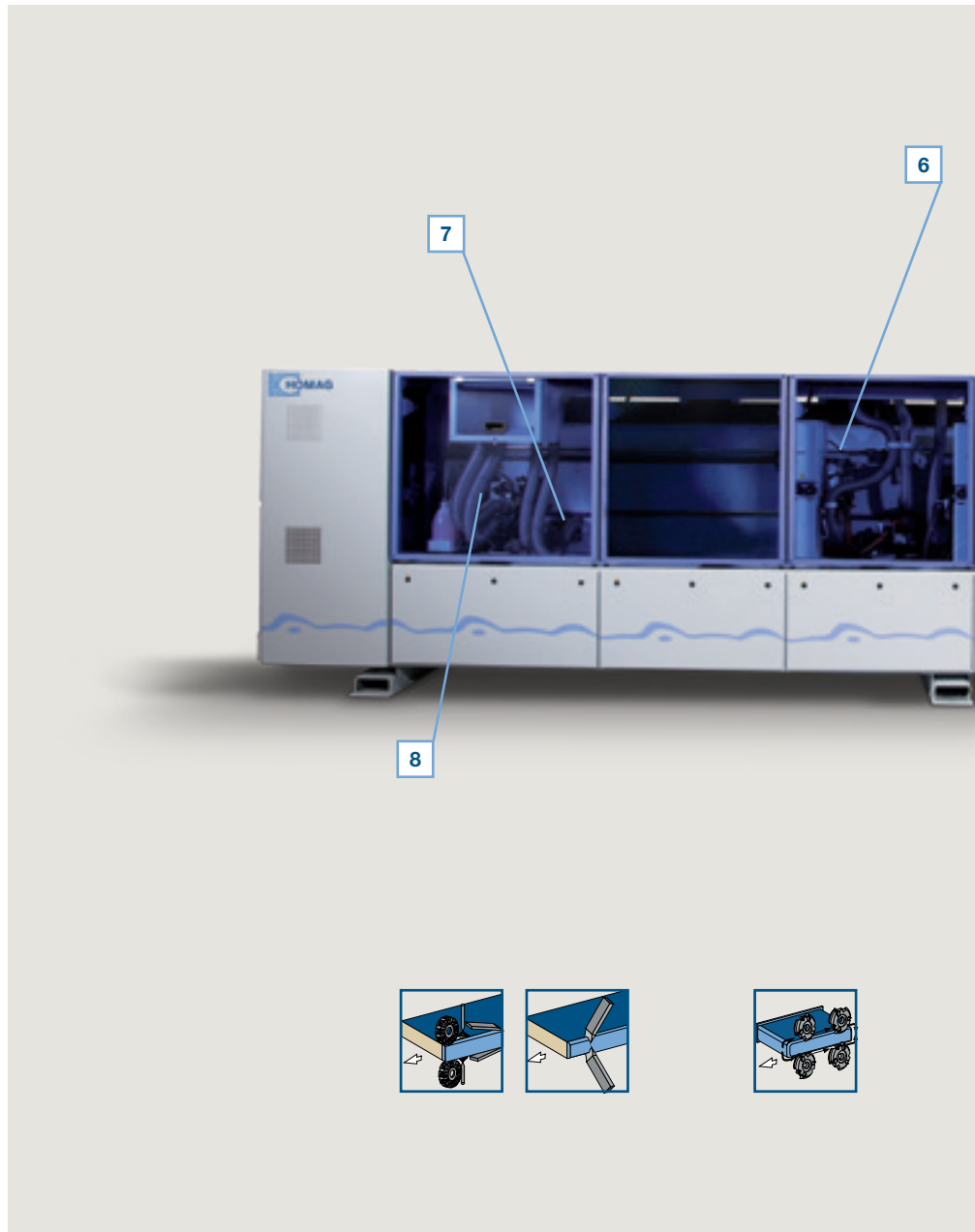

## Ambition 2671: Everything you need

Edge bands can be glued and finished processed on the Ambition 2671, including rounding of face sides. PU can also be used on request. The buffing unit at the outfeed imparts a perfect grip to your edges. A sanding or grooving unit can

be mounted at the free space. The choice is yours. The feed speed of 30 m/min opens up scope for higher productivity.

**Feed speed: 16 – 30 m/min**



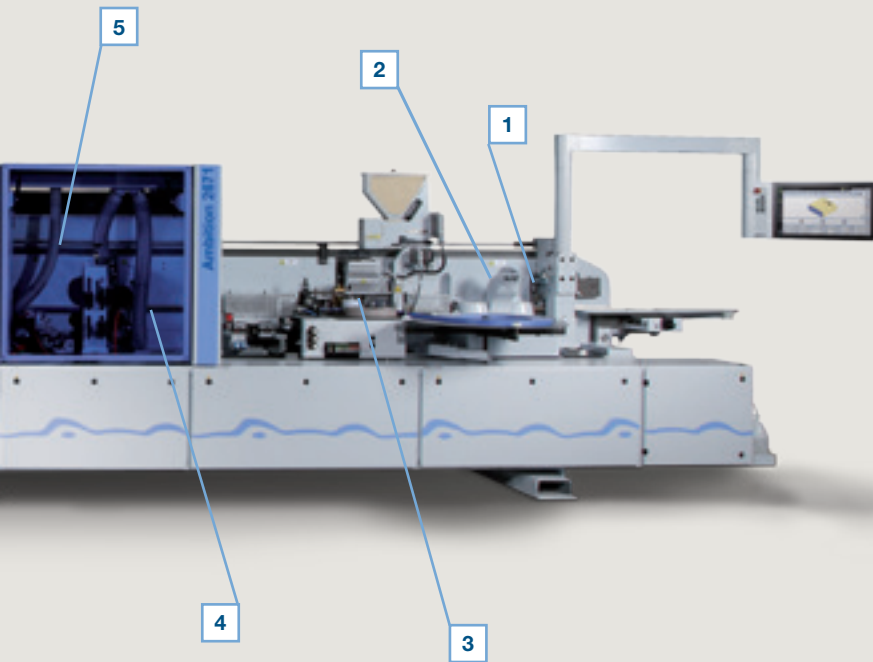

### Ambition 2671

- 1** Separating agent spraying unit
- 2** Jointing trimming unit
- 3** Gluing unit with 2 coils
- 4** Free space rough trimming unit BF10
- 5** Chamfer/radius trimming unit PF20
- 6** Profile trimming unit FF30
- 7** Profile scraper unit PN10
- 8** Finishing unit FA21

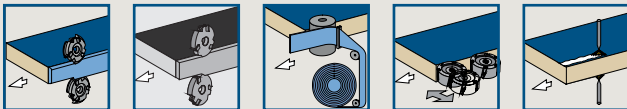

Option

## MATERIAL TYPES

e.g.

- 0.4 mm melamine
- 2 mm PVC
- Veneer (coil)

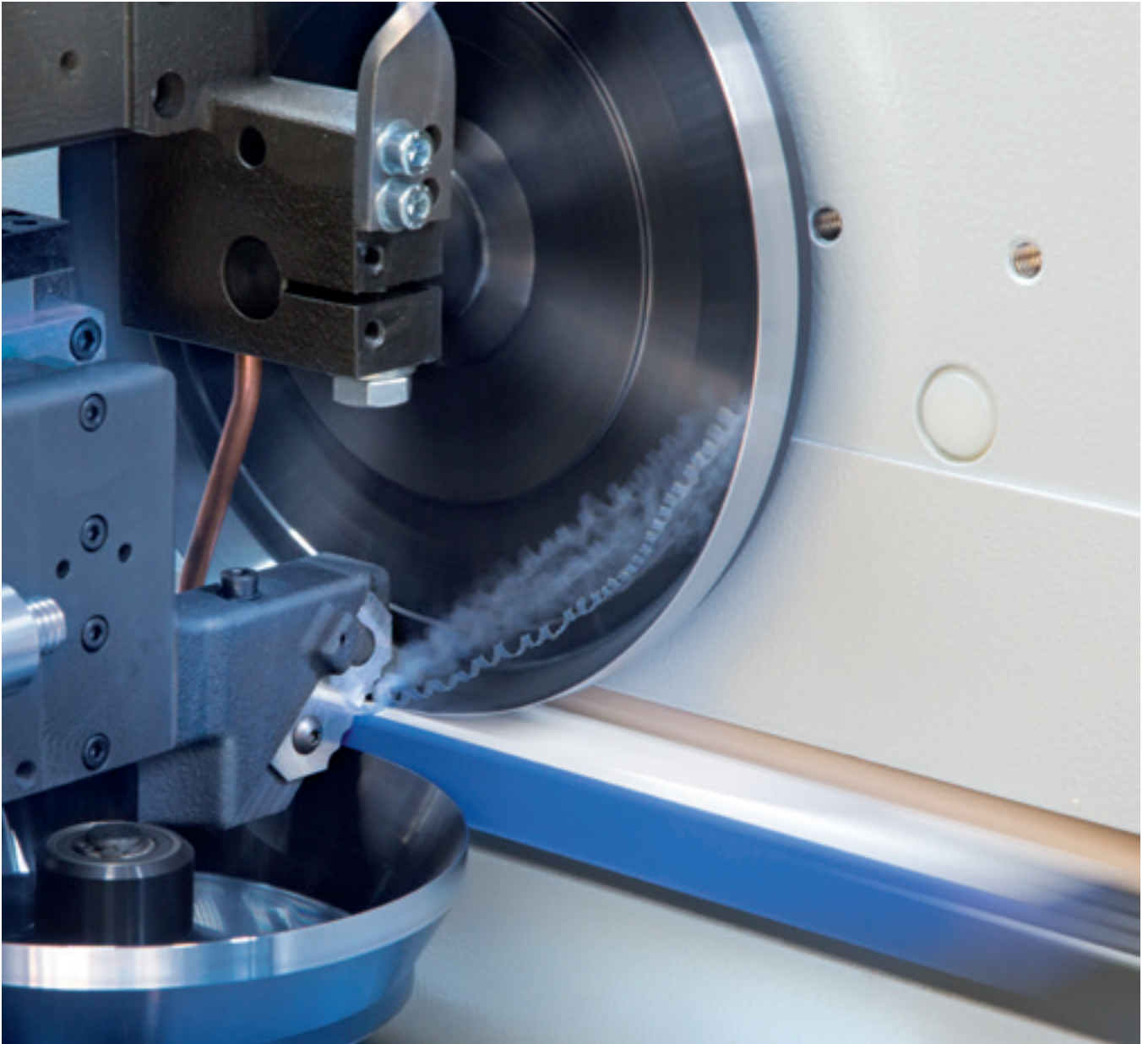

## Our range of modular units: The right solution no matter what the requirement

For wide-ranging different processing tasks, we use units from our tried and tested modular range. By continuously extending the offered functions, we ensure that you have the right solution available to cope with changing trends. Presenting a range of units for jointing trimming, gluing,

snipping, profile trimming, grooving and finish processing. Their extreme precision and state-of-the-art technology will boost the flexibility and efficiency of your production.

## Workpiece feeding

Precise workpiece feeding is a pre-condition to achieve perfect edge quality. Our solutions are your benefit: infeed

fence, infeed stop, sliding carriage or workpiece support.



### Infeed stop

For minimum workpiece spacing and safe operation.  
With Ambition 1600 – 1800.



### Infeed stop

Pneumatically controlled.  
With Ambition 2200 – 2600.

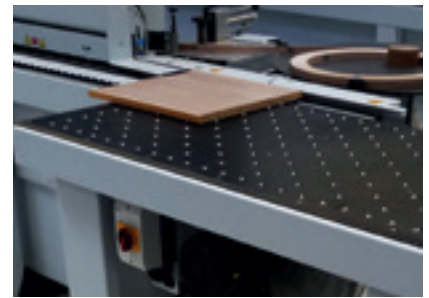

### Air cushion table

For easy workpiece feeding.



### Automatic infeed fence adjustment

Program-controlled precision adjustment with precise infeed fence adjustment by means of servo axis.  
With Ambition 1600 – 2600.  
Photo = Ambition 2200 – 2600.



### Sliding carriage

Robust linear guiding system to secure rectangular workpiece feeding.  
With Ambition 1600 – 2600.  
Photo = Ambition 2200 – 2600.

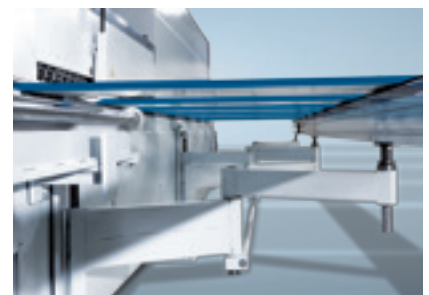

### Scissor-design workpiece support

The workpiece support in scissor-design is conveniently extendable to 1,000 mm.  
With Ambition 1600 – 2600.

## Spraying units

Spraying units help to improve edge quality throughout the complete processing. Separating agent and antistatic agent avoid that hot melt glue residuals and plastic chips adhere to the workpiece. Cleaning agent help to easily remove

glue residuals. Lubricant is applied to protect sensitive surfaces before trimming and to prevent gloss marks on the workpieces.



### **Spraying unit for the application of lubricant**

To achieve optimum processing quality even with sensitive surfaces. With Ambition 1600 – 2600.



### **Spraying unit for the application of separating, antistatic and cleaning agent**

Prevent the adhesion of hot melt glue residues or dissolve them on the upper and lower side of the workpiece. With Ambition 1600 – 2600.

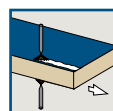
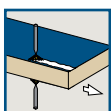

## Jointing trimming units

The HOMAG jointing trimming units provide the perfect basis for splinter-free glue joints with a consistently high standard of product quality.



### Jointing trimming unit

Perfect cut and high operating life due to diamond tipped tools for an optimum edge joint quality. The diameter is 100 mm.  
With Ambition 1600 – 1800.

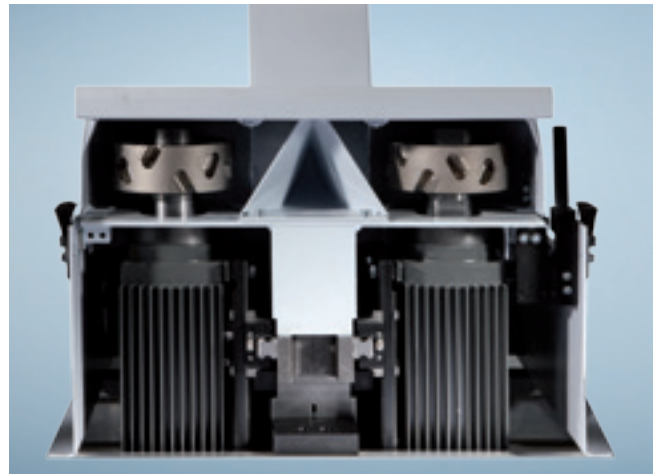

### Jointing trimming unit

This unit permits a high level of processing precision, is extremely hardwearing and is also designed to ensure an above-average service life. The diameter of the low-noise flying chip-optimized tool (I-system) is 125 mm.  
With Ambition 2200 – 2600.

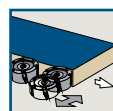

## Gluing units – reliable hot melt glue application

HOMAG gluing units are ideal for a fast, positive-locking glue bond. An EVA pre-melting unit (from Highflex 1600) comes as standard. The heated glue roller ensures an optimum gluing temperature. The magazine height adjustment (Ambition 2200 – 2600) permits different edge heights to

be processed with a consistent workpiece thickness. On request, the gluing unit can also be individually equipped with a PU pre-melting unit – allowing rapid changeover between two different colors or PU.

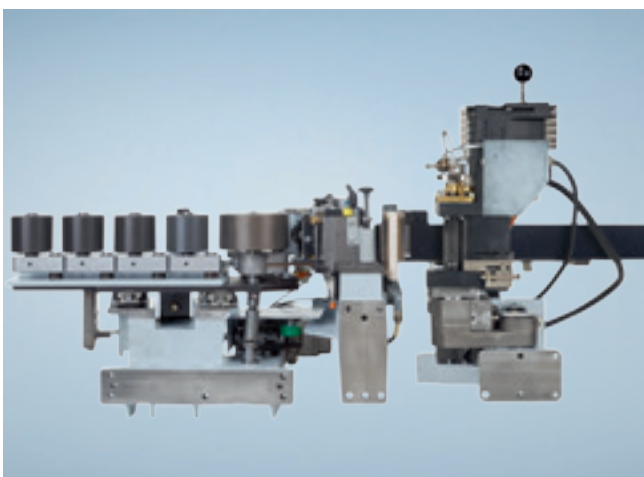
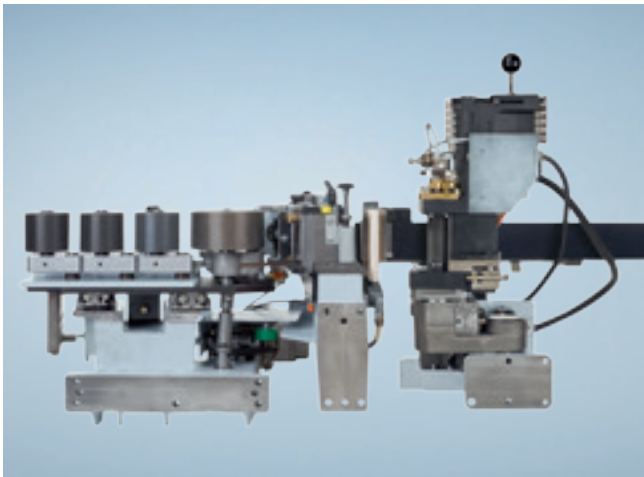

### **Gluing unit**

Quick-change application unit.

Can process PU granulate.

Top image: with Ambition 1600.

Bottom image: with Ambition 1800.

### **YOUR BENEFITS AT A GLANCE**

- Short heating-up time by sensed level control (2 levels selectable)
- Simple removal of the application unit with quick-release lock
- Pre-melter for melting hot-melt glue as required either manually or automatically
- Glue roller with integrated heating guarantees constant temperature and viscosity for all workpiece thicknesses
- Electropneumatic glue roller and tank clamping prevents glue soiling on the trailing edge of the workpiece
- Tracing pad prevents wear of the application roller and ensures a consistent glue film thickness
- Glue roller lift-off on feed stop

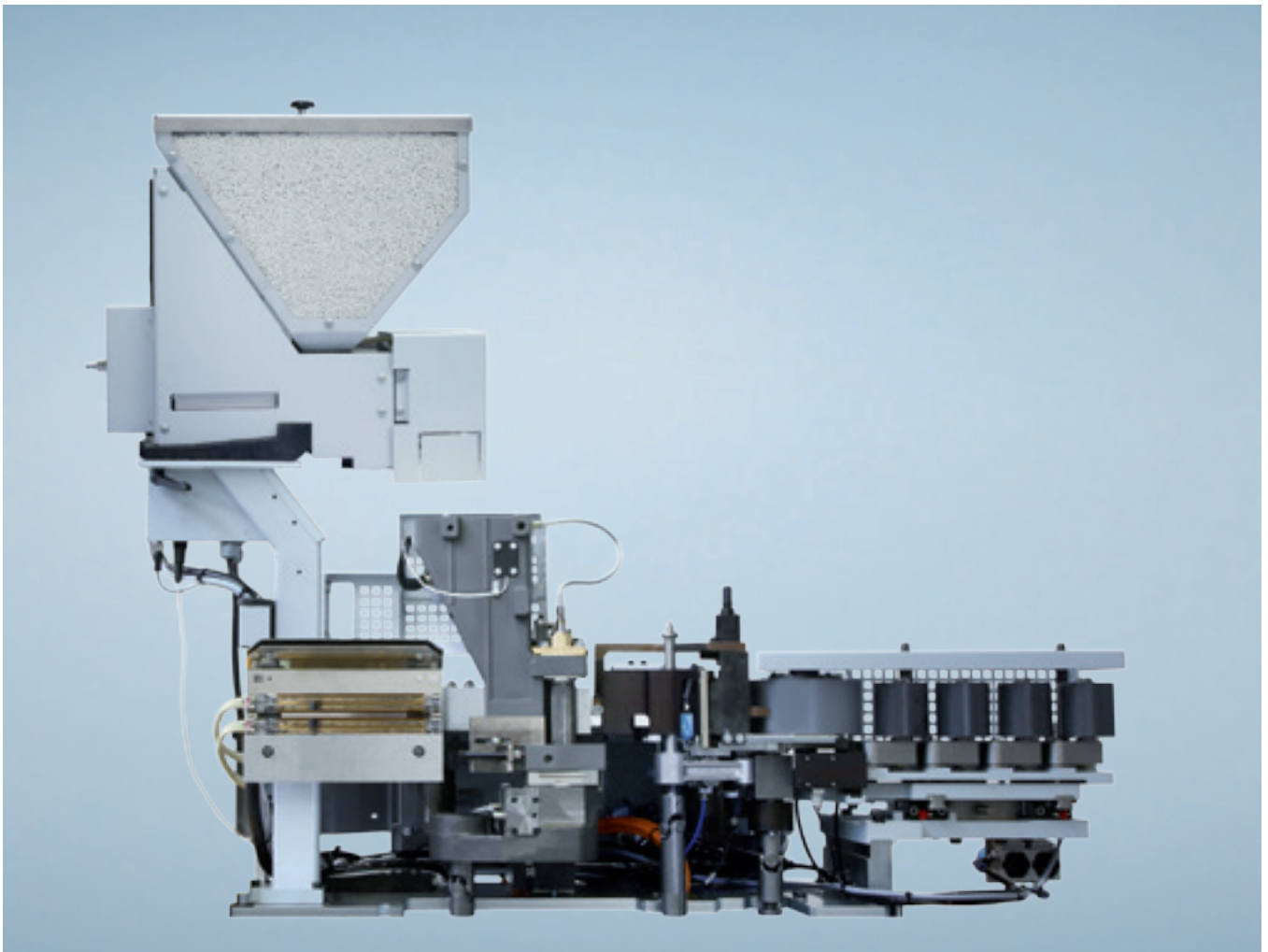

**Hot-melt gluing unit**

For processing coil material from 0.3 – 3 mm. With Ambition 2200 – 2600.

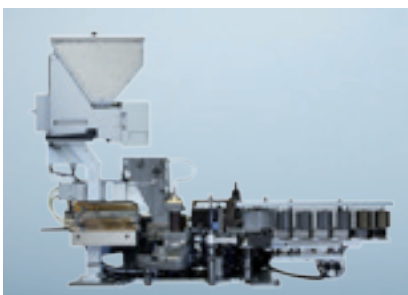

**Hot-melt gluing unit with solid wood package**

For processing coil material from 0.3 – 3 mm and solid strips of up to 20 mm. With Ambition 2200 – 2600.

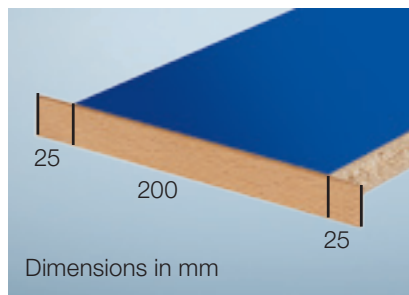

**Previous gluing technique**

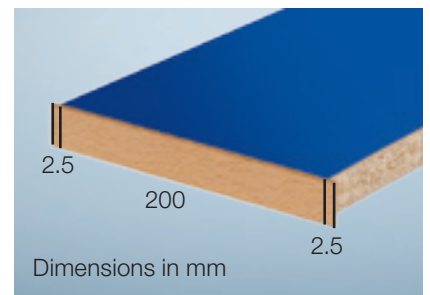

**Optimized gluing technique with servo edge feed**

Edge feed with a precision of +/- 2 – 3 mm at the leading and trailing edge to reduce edging material waste. With Ambition 2200 – 2600.

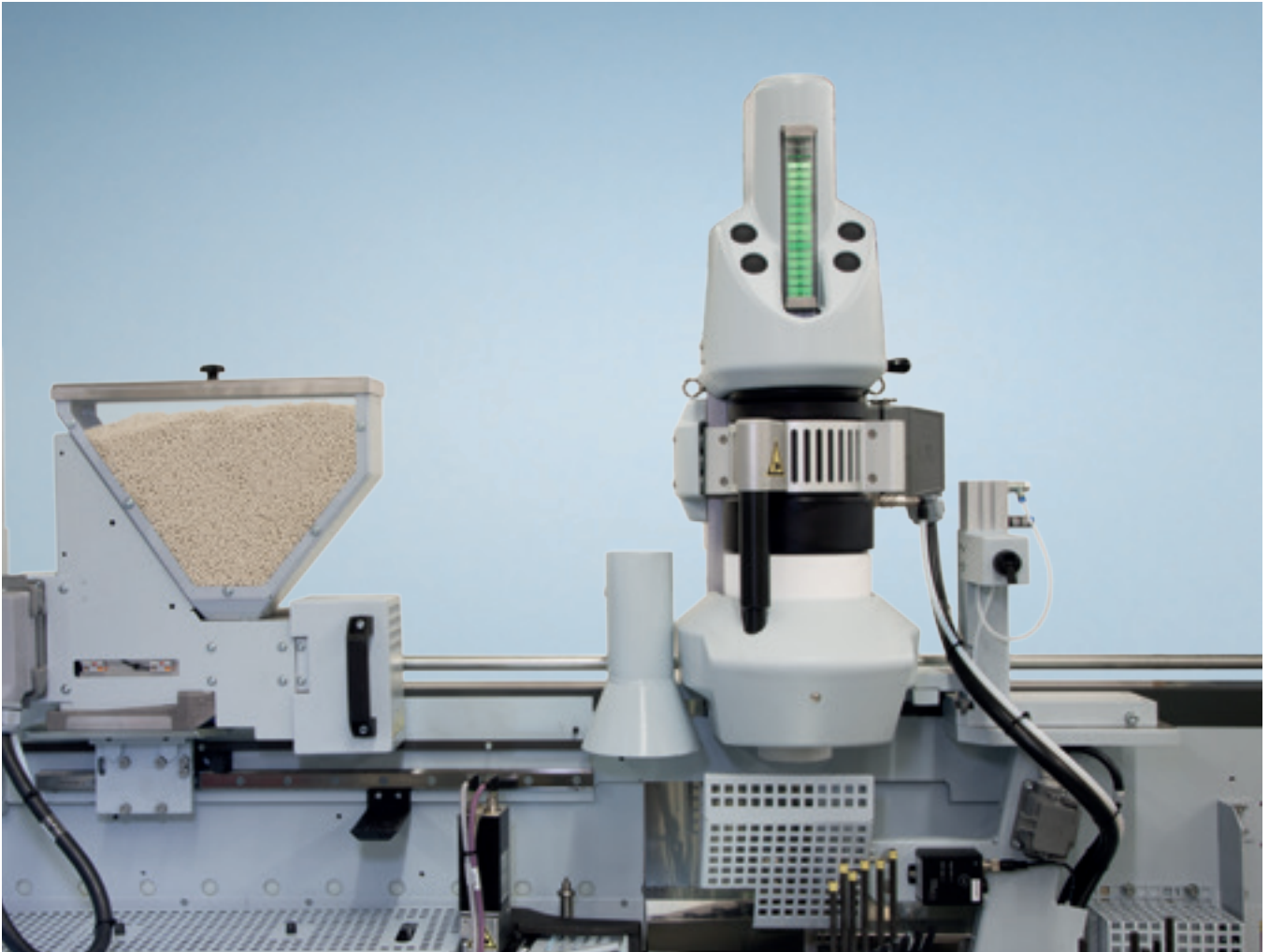

### Processing PU glue

To cope with the special requirements when it comes to humidity- and heat-resistance the Ambition models allow the use of PU glue with a standardized glue application system from above.

Photo = Ambition 2200 – 2600.



### PU packages

For the Ambition models 2200 – 2600 two PU packages are available.

- PU package for the processing with PU glue instead of hot melt glue
- PU package for the optional processing with either hot melt glue or PU glue



### PU pre-melting unit

Melting output 2.5 kg/h.  
With Ambition 1600 – 1800.



### Service station

Easy cleaning, filling and draining of the application unit.

- Holding devices for 2 application units
- One preheating unit including temperature control and glue roller drive



## Systematic gluing

To achieve a perfect gluing it is decisive that entirely different factors interact in an optimum way. The HOMAG panel pre-

heating, application unit, quick clamping device, melting unit, magazine and pressure zone match perfectly.



### Workpiece pre-heating

High-strength glueing due to an optimum workpiece pre-heating.

With Ambition 1600 – 2600.

Photo = Ambition 1600 – 1800.

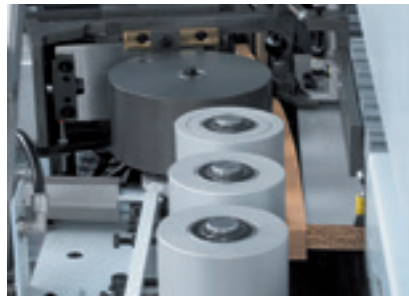

### Pressure zone

Pressure zone (up to 20 mm) for an optimal glue joint.

With Ambition 1800 – 2600.



### Wide solid strips

Extra wide magazine with high capacity for solid strips and optimum access to reload.

With Ambition 1600 – 2600.

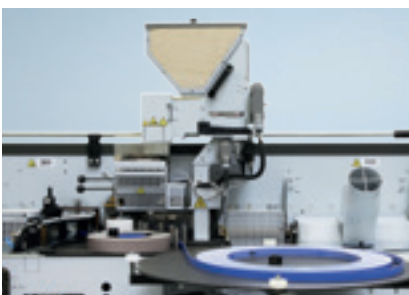

### Melting unit with granulate tank

For storage and pre-heating of hot melt glue granulate.

With Ambition 2200 – 2600.

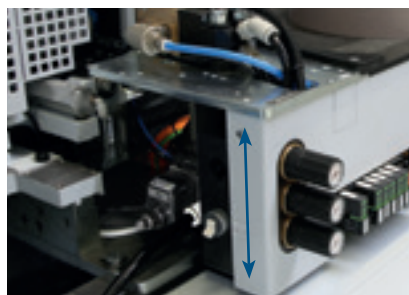

### Magazine height adjustment

For processing coil material from 0.3 – 3 mm and solid strips of up to 20 mm. Different edge thicknesses can be processed with a single edge height.

With Ambition 2200 – 2600.

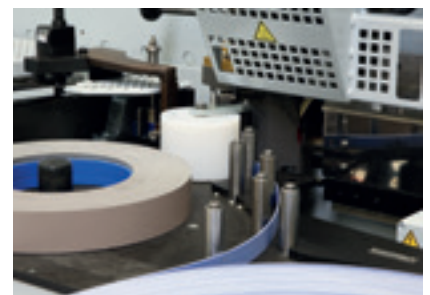

### 2-coil magazine

Edge feeding and 2 horizontal coil magazines. Servo-driven edge feeding to reduce edge material waste.

With Ambition 2200 – 2600.

## airTec – the ideal entry into zero joint technology

The airTec process has become an established zero joint solution in woodworking shops and SMEs. The HOMAG's answer to the growing demand is an innovative, more efficient and resource-saving airTec solution. The nerve center of the new airTec unit is a rotation air heater which not only enhances efficiency but also operates with significantly

lower noise emissions. airTec can be used to process all types of currently popular, laser suitable edging types. This means great flexibility for all materials and colors.



### Edge banding with “no joints”

The airTec method bonds the edging to the panel using hot air. This requires the use of special edging materials. These comprise a decor layer and a function layer. The HOMAG airTec unit melts the function layer at an even temperature and flow rate and bonds it perfectly to the narrow surface.

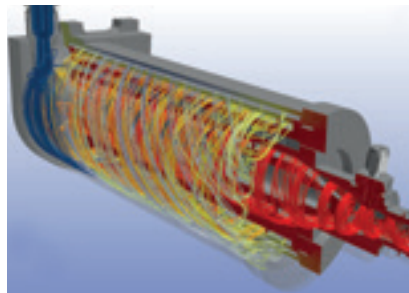

### Innovative rotation air heater

The new source of energy heats the air while at the same time acting as a heat store for subsequent repeated air heating. It also works with reduced air consumption and reduces heating of the surrounding atmosphere. Almost the only noise generated is emitted during the activation process, and is below the noise level of the other processing units.

## BENEFITS

- Reduction of noise
- More efficient, resource-saving operation
- Even air flow for high quality
- Rapid changeover between airTec and traditional gluing technology
- Simple operation with powerTouch

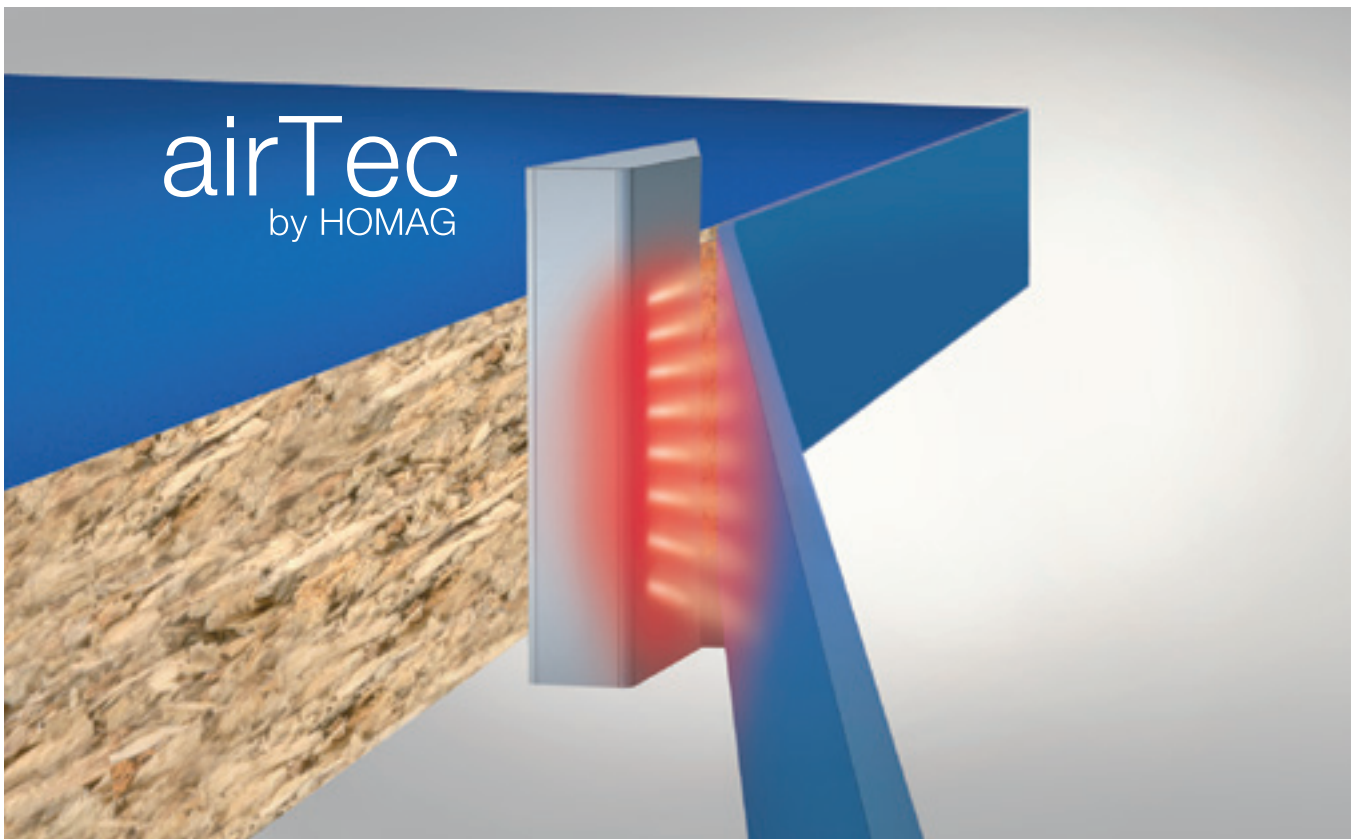

#### airTec unit

On the Ambition 1600 – 1800 series airTec is installed in a way that it is possible to use either the standard application unit or the airTec system.

The antistatic spraying unit for an optimum processing result comes as standard with all airTec units.

For the models Ambition 1650 airTec and Ambition 1860 airTec the airTec unit is standard.



#### airTec unit

With the Ambition models 2200 – 2600 the airTec unit is also applicable for shift operation.



#### sealTec – HOMAG Hydrophobing

HOMAG sealTec was especially developed to be used in combination with the optical zero joint such as airTec. The existing high quality of the zero joint gluing is further increased by HOMAG sealTec regarding the water and water vapor resistance. With Ambition 2200 – 2600.

## Snipping units for cutting the overhang on the front sides

The snipping units prepare the workpieces perfectly for subsequent trimming operation.

The face side can be snipped either straight or with chamfer.

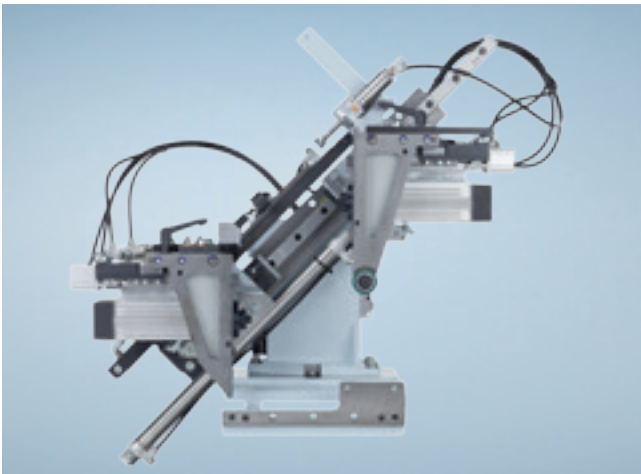

### Snipping unit

Exact snipping cut via a robust snipping unit with a highly precise linear guide and workpiece gap optimization (optional) to achieve higher output in the same processing time. Soft-touch function for optimal snipping results even at high speeds. With Ambition 1600 – 1800.



### Snipping unit HL81

For a clean snipping cut of overhanging edges on leading and trailing workpiece edges using the drawing cut technique. With Ambition 2200 – 2600.

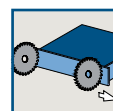
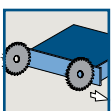

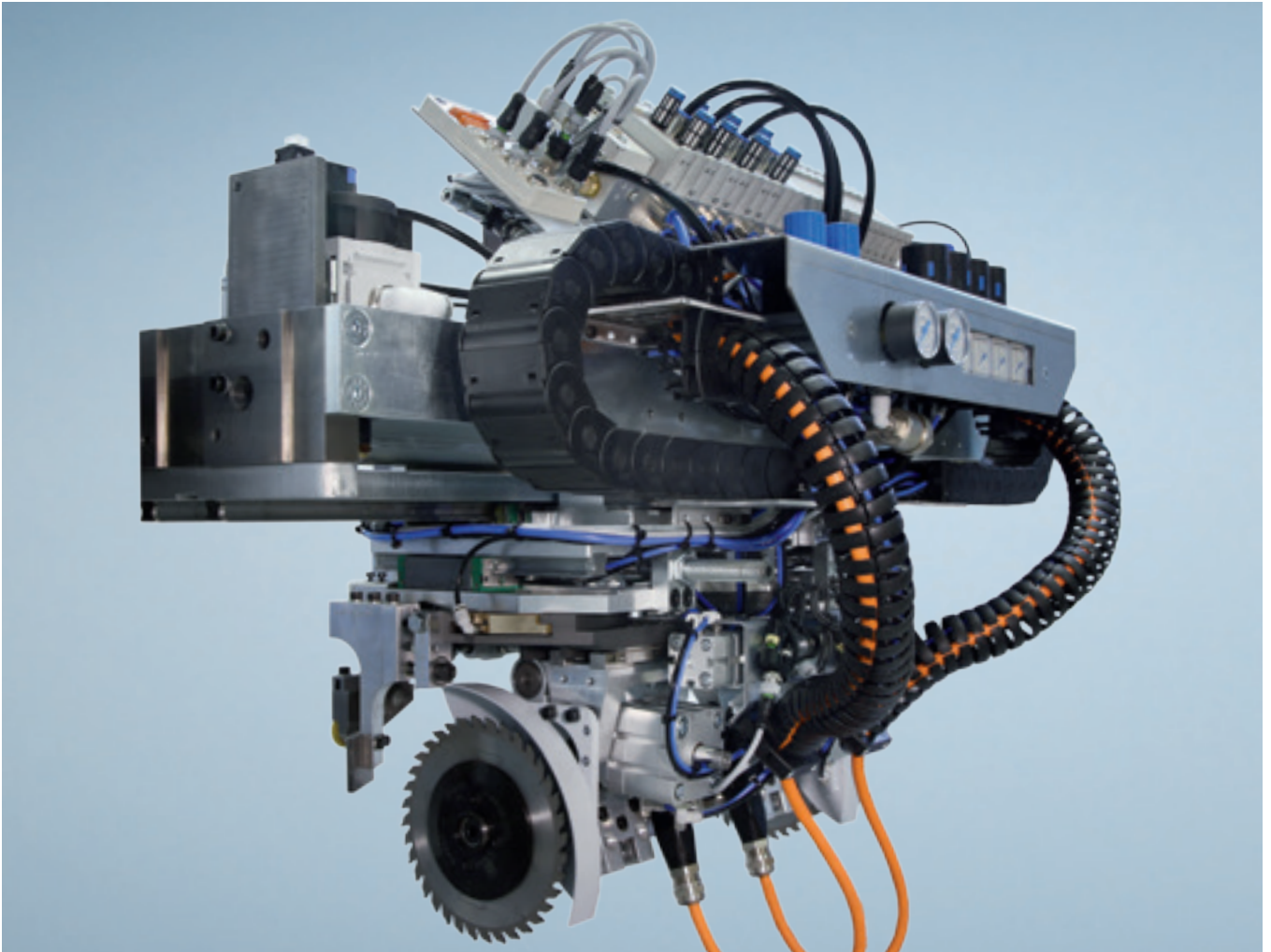

**Snipping units PK25 and PK30**

For snipping the edge overhang at the leading and trailing workpiece edge with stationary snipping stop to protect sensitive workpieces from damage.



**Snipping units PK25 and PK30**

- Feed speed
- PK25 = 25 m/min
  - PK30 = 30 m/min

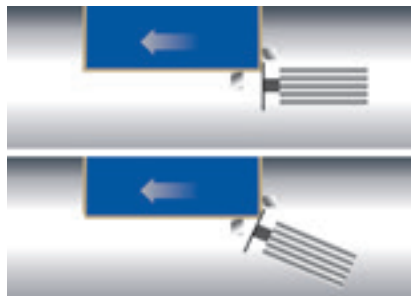

**Automation as standard**

Programmable chamfer/straight snipping motor adjustment for fast changeover between straight snipping and snipping with chamfer.

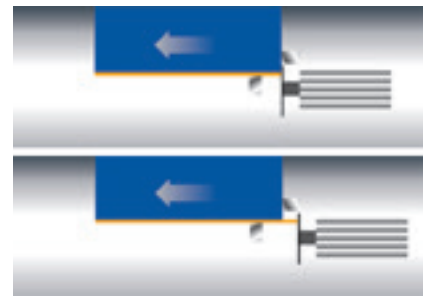

**Automation to suit every need**

For fast changeover between flush snipping (e.g. of solid strips or inlay shelves) and snipping with overhang (e.g. for finish trimming with profile trimming unit).

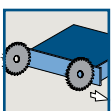

## Trimming units for flush trimming

With the rough trimming unit and the fine trimming unit HOMAG offers the right solution for the processing of projecting edges. The trimming units are equipped exclusively with tools which capture the chips controlled. This and the HOMAG-patented HSK interface (Ambition 2200 – 2600) ensure a high standard of processing quality and a long tool life.

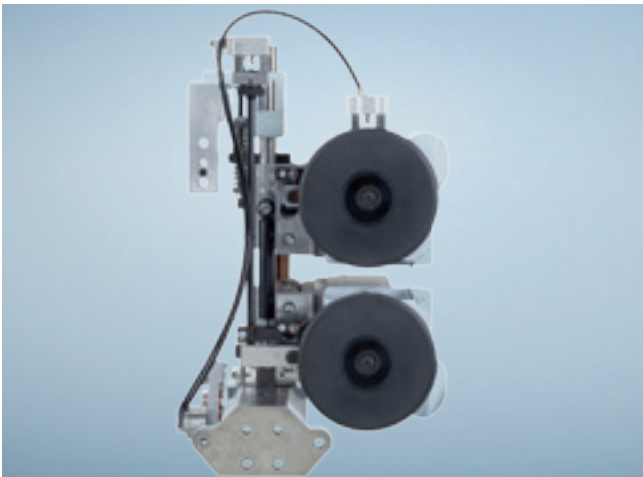

### Rough trimming unit

For rough trimming of all common edge banding materials.  
With Ambition 1600 – 1800.



### Rough trimming unit

For rough trimming the upper and lower edge overhang.  
With Ambition 2200 – 2600.

### Automation to suit every need

Automatic changeover from flush trimming to trimming with projecting edge using 2-point-adjustment.

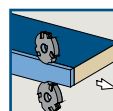



**Fine trimming unit**

For trimming chamfers and radii with optimized chip extraction and manual adjustment.

With Ambition 1600 – 2600.

**Automation to suit every need**

Stepless chamfer/radius adjustment for rapid changes between processing operations, e.g. from 0.4 mm to 2 mm edge.

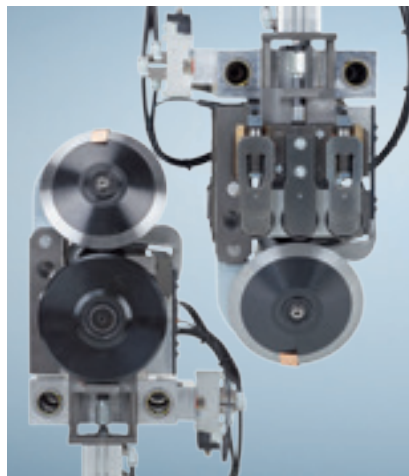
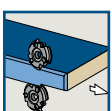

**Multi-stage trimming unit MS40/45**

Fully automatic adjustment between 3 different profiles by means of servo motors.

Image shows nesting package.

With Ambition 1600 – 1800.

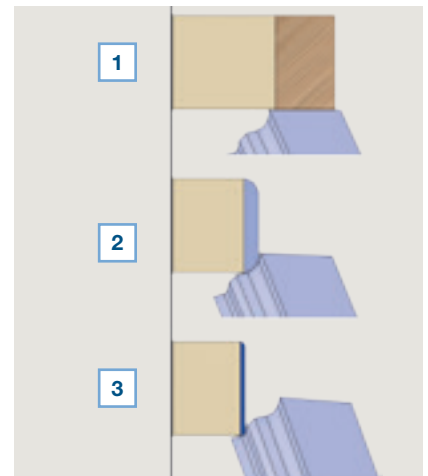
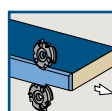

**1 Without profile (MS40/45)**

**2 Profile 1**

**3 Profile 2**

## Profile trimming units for Ambition 1600 – 1800

HOMAG profile trimming units are universal. The user has the choice to adjust the units manually or to control them via program. High precision adjustment up to speeds of 20 m/min.

Our profile trimming units permit both corner rounding and trimming of upper and lower projecting edges.

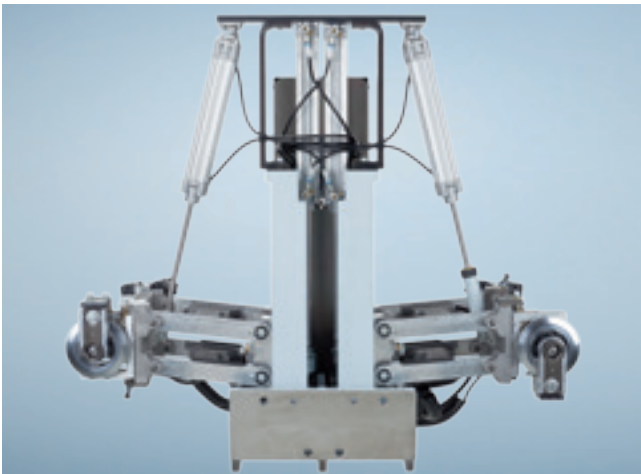

### Profile trimming unit FF20

For rounding corners on thick PVC edges, as well as top edges on post-forming and soft-forming parts. Equipped with an automatic adjustment to switch between thick and thin edges. Workpiece thickness up to 60 mm.

With Ambition 1600.

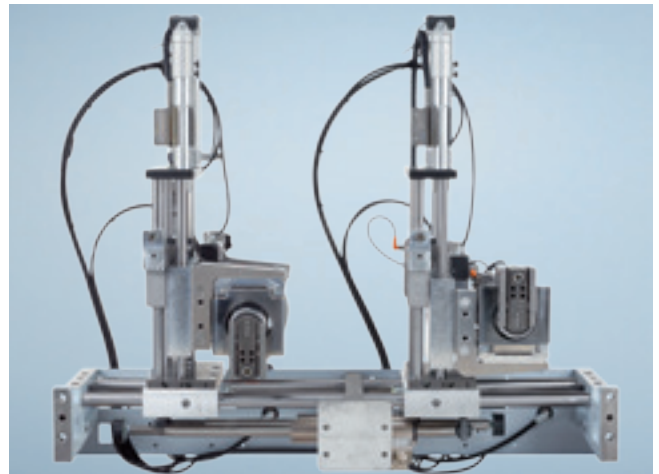

### Multifunctional trimming unit MF50

Trimming of the edge overhang on top and bottom side as well as contour trimming on the front and rear edges. Equipped with an automatic adjustment to switch between thick and thin edges. Workpiece thickness up to 60 mm.

With Ambition 1600.

### Automation to suit every need

Adjustment to two different radii and automatic adjustment of the tracing rollers.

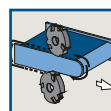
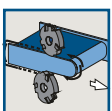



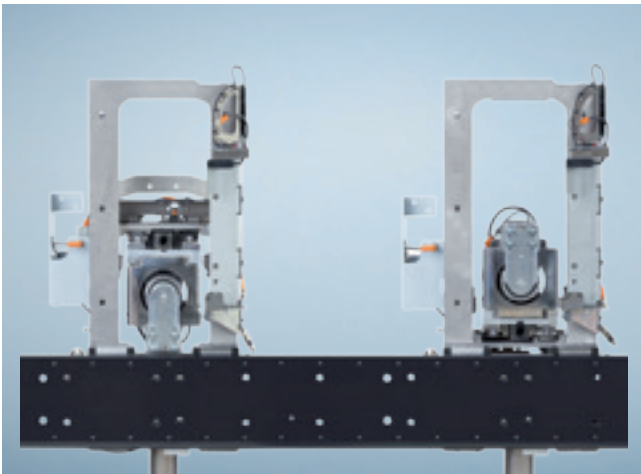

#### Multifunctional trimming unit MF60 Servotrim

For processing the edging overhang at the upper and lower edge of the workpiece as well as for corner rounding of the front and rear edge. Servo-controlled movement with soft-touch function for optimal handling of e.g. high gloss surfaces or light weight panels. Workpiece thickness up to 100 mm. With Ambition 1600 – 1800.

#### Automation to suit every need

Adjustment to two different radii and automatic adjustment of the tracing rollers.

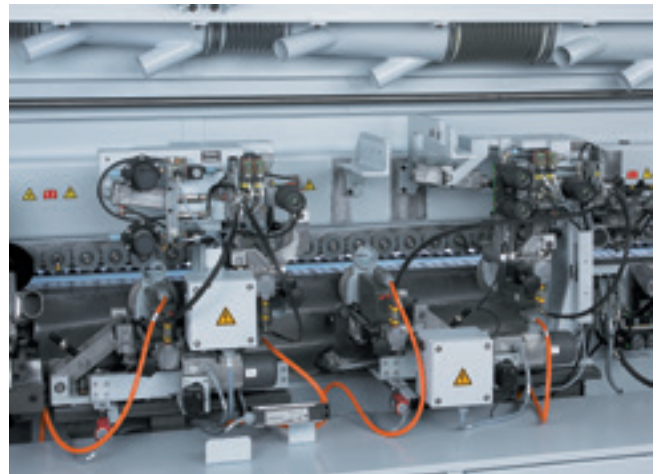
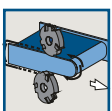

#### Profile trimming unit FF12

For corner rounding of thick PVC edges, as well as postforming and softforming profiles at feed speeds of up to 20 m/min. Equipped with servo motor adjustment for different edge thicknesses. Workpiece thickness up to 60 mm. With Ambition 1800.

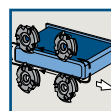

## Profile trimming units for Ambition 2200 – 2600

The profile trimming units are universal. As a user, your job is to program any profile that takes your fancy: Then stand back and watch the extreme speed and precision of the expert execution. The efficient mode of operation results in

higher productivity. Our dual-motor profile trimming units permit both corner rounding and trimming of upper and lower projecting edges.

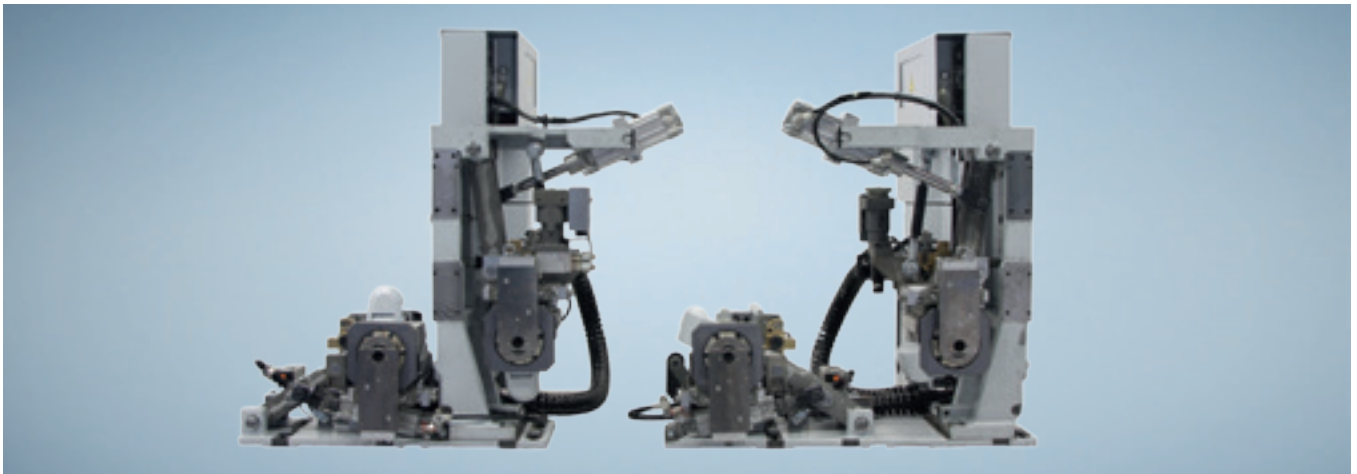

### **Profile trimming unit FF30**

For rounding edges at the leading and trailing workpiece edge top and bottom at a constant feed speed.

With Ambition 2200 – 2600.

### **Automation to suit every need**

Chamfer/radius adjustment (2-point-adjustment) for rapid changes between processing operations, e.g. from 0.4 mm to 2 mm edge.

### **Profile trimming unit FF32**

For rounding edges at the leading and trailing workpiece edge top and bottom at different feed speeds. By dividing the cut over four motors, each corner can be processed in synchronous rotation.

This lends corners a perfect trimmed finish for every edging type – even with veneer. Workpiece thicknesses and feed speeds are automatically adjusted without manual intervention.

With Ambition 2200 – 2600.

### **Automation to suit every need**

Stepless chamfer/radius adjustment for rapid changes between processing operations, e.g. from 0.4 mm to 2 mm edge.

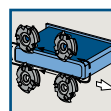
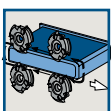

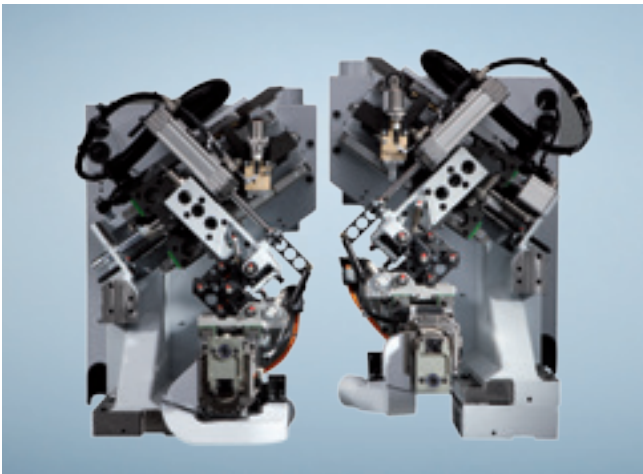

**Profile trimming unit FK11**

For processing overhanging edges and trimming around the leading and trailing edge.  
With Ambition 2200 – 2600.

**Automation to suit every need**

Stepless chamfer/radius adjustment for rapid changes between processing operations, e.g. from 0.4 mm to 2 mm edge.

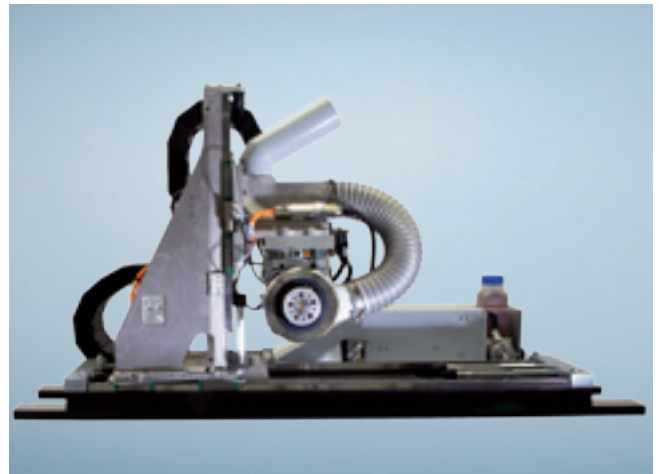
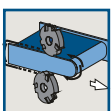

**Profile trimming unit FK30**

For trimming around the leading and trailing edge.  
With Ambition 2200 – 2600.

**Automation to suit every need**

Adjustment to two different radii and automatic adjustment of the tracing roller diameter.

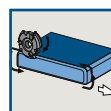

## Grooving units and belt sanding unit

Depending on the requirement and the Ambition model various grooving units are available. With Ambition 2200 – 2600 a grooving unit can be selected if

there is a free space. The belt sanding unit can also be installed on Ambition models coming with a free space.

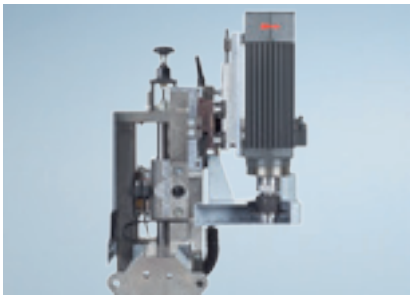

### Tiltable grooving unit

For grooving work pieces either from the bottom side or from the edge side. It is possible to do either continuous grooving or non continuous grooving, as well as jump grooving for biscuit joints. With Ambition 1600 – 1800.



### Universal trimming unit

Universal unit with high capacity for grooving and profiling work. Flexible by unlimited setting options. With Ambition 1800.

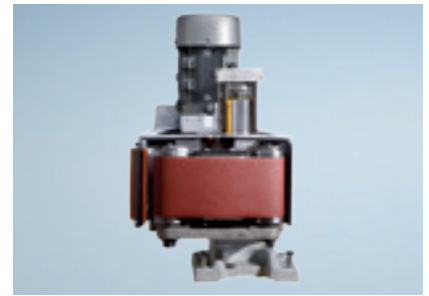

### Belt sanding unit KS10

For sanding straight veneered and solid edges including oscillation as a standard feature. With Ambition 2200 – 2600 with free space.



### Grooving unit SF21

For grooving, rebate trimming and profiling. With Ambition 2200 – 2600 with free space.

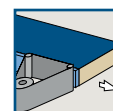
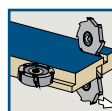
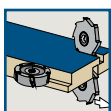

## Additional units to address your individual needs

For the individual upgrade of the functional scope of the machines the equipment packages “Foil / high-gloss”, for

perfect high-gloss panel processing, and “Nesting”, for processing of e.g. panels with hinge holes, are available.

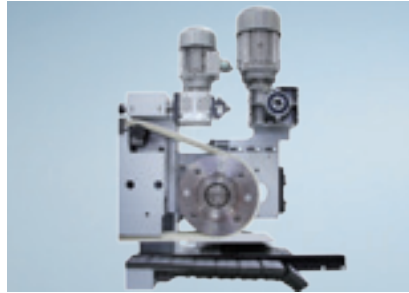
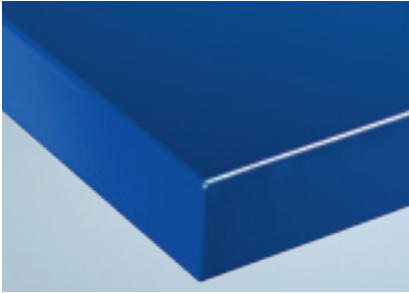

### Foil / high gloss packages

For perfect high gloss parts, important components such as motor-powered top pressure beam and automatic glue joint scraper adjustment are used.

Choose between the two foil / high gloss packages for the processing of workpieces

- on the upper and / or lower edge
- on the lower edge

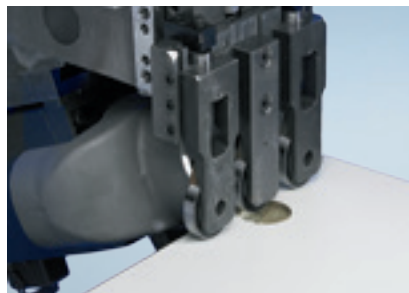
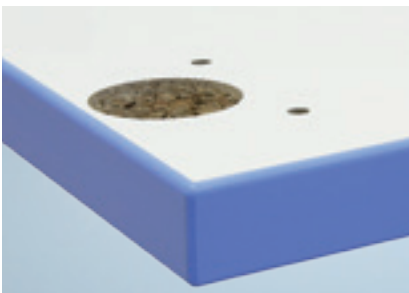

### Nesting package

Different tracing elements are mounted depending on the unit configuration. These are ideal for processing acute or obtuse-angled parts or parts with hinge holes of the type produced by nesting.

### Tracing elements nesting package

With Ambition 1600 – 1800.

### Tracing elements nesting package

With Ambition 2200 – 2600.

**Multi-stage scraper unit MZ40**

Fully automatic adjustment between 2 different profiles by means of servo motors with a stepless adjustment.  
With Ambition 1600 – 1800.

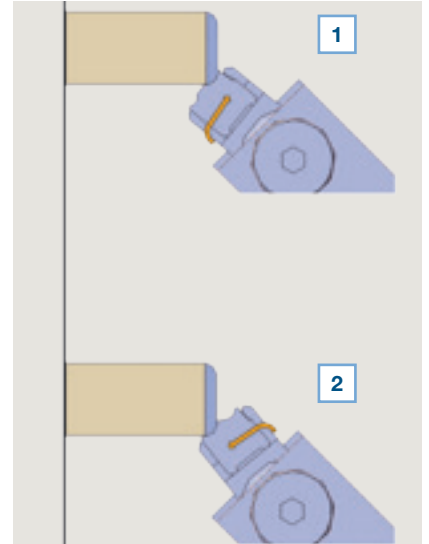
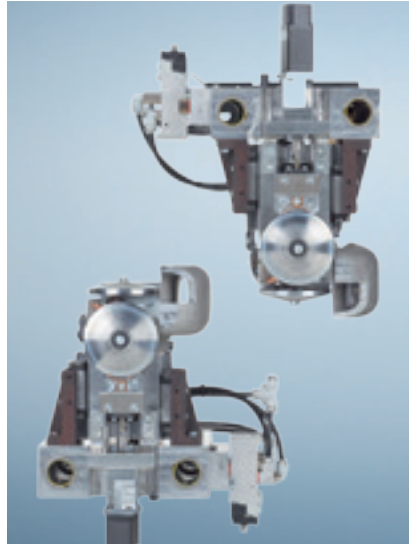

**1 Profile 1**

**2 Profile 2**

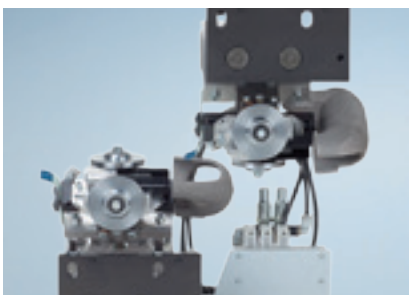

**Profile scraper unit**

Unit to smooth radii or chamfers, equipped with quick change heads for fast profile change.  
With Ambition 1600 – 1800.

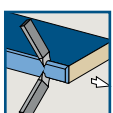

**Glue joint scraper unit**

For the perfect finish.  
With Ambition 1600 – 1800.

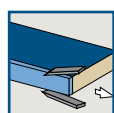

**Buffing unit**

To polish edges and maintain their natural color.  
With Ambition 1600 – 1800.

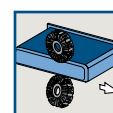

## Finishing units

The quality of your products is increased by the use of perfectly coordinated finishing units. With ideally coordinated

finishing units, HOMAG adds a perfect, high-quality final touch to your products.

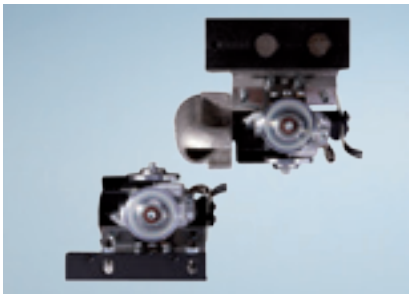

### Profile scraper unit PN10

For smoothing trimmed edges to achieve an optimum appearance.  
With Ambition 2200 – 2600.



### Finish processing

Comprising a glue joint scraper unit for disposal of glue residues at the top and bottom of plastic edges and a buffing unit.  
With Ambition 2200–2600.



### Multi scraper MN21

For smoothing trimmed edges for an optimum appearance. Optimum resetting for different profiles, corrections to a pinpoint standard of accuracy. Reproducible quality to the highest standard.  
With Ambition 2200–2600 with free space.



### Automation to suit every need

Automatic move-in / move-out from the work area via pneumatic adjustment.



### Automation

Automatic resetting to different profiles, corrections within the one-hundredth range. Reproducible quality to the highest standard.

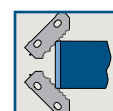
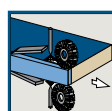
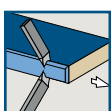



### Control with powerTouch

Using the widescreen format multitouch monitor, you control machine functions by direct touch contact. The ergonomically optimized design and an array of new help and assistant functions substantially simplify operation.



### Standardized

Standardized operating elements, software modules and standardized design characterize the powerTouch control system for HOMAG machines. This allows different HOMAG machines to be controlled in the same way.



### Ergonomic

Intuitive, direct control via the touch-sensitive touchscreen monitor.



### Evolutionary

Design and function united in one control system. The futuristic powerTouch machine control system is combined with state-of-the-art operating concepts used in smartphones and tablet PCs.



## powerTouch – the innovative control system: Easy, standardized, ergonomic and evolutionary

HOMAG machines are designed to make easy operation and reliable control a matter of course. Our innovative touchscreen operating philosophy combines design and function in a single control system.

The full HD multitouch monitor, ergonomic touch operation, simple navigation and the standardized user interface all enhance processing efficiency.

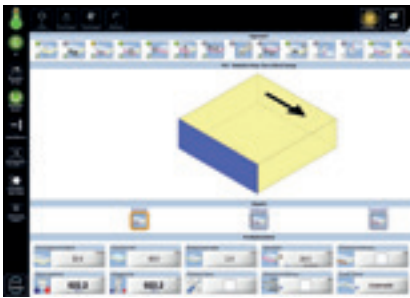

### Programming with woodCommander

User-friendly programming system using graphically supported input screens.  
With Ambition 2200 – 2600.



### Support via TeleServiceNet Soft

High-speed servicing and assistance through targeted troubleshooting and support over the Internet.



### Evaluation with MMR Basic

The software evaluates the productivity of your machine and supplies usage-dependent maintenance notifications.  
With Ambition 2200 – 2600.

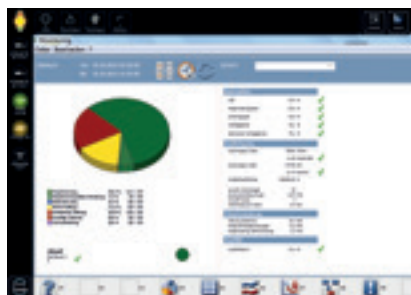

### MMR Professional (option)

The MMR Basic upgrade additionally evaluates shifts, analyzes error messages and permits a link to be created to the data evaluation center in the office.  
With Ambition 2200 – 2600.



### woodScout diagnostic system (Option)

Alongside error messages in plain text, woodScout also provides a graphic representation of the error location. In addition to the system's expert knowledge database, users can store their own troubleshooting solutions.  
With Ambition 2200 – 2600.

## BOOMERANG® return feed systems: Increased productivity for edge banding machines

Workpiece return feed systems of the BOOMERANG® series provide the ideal complement to the machines of Ambition 1600 – 2600 series. With one-man operation the panel return flow is optimized and allows a lean and efficient production process. Depending on the individual

requirements the Ambition can be combined with a TFU 120 or a TFU 140/20. The TFU 521 edition can be integrated in the HOMAG control with the Ambition 2200 – 2600 series.

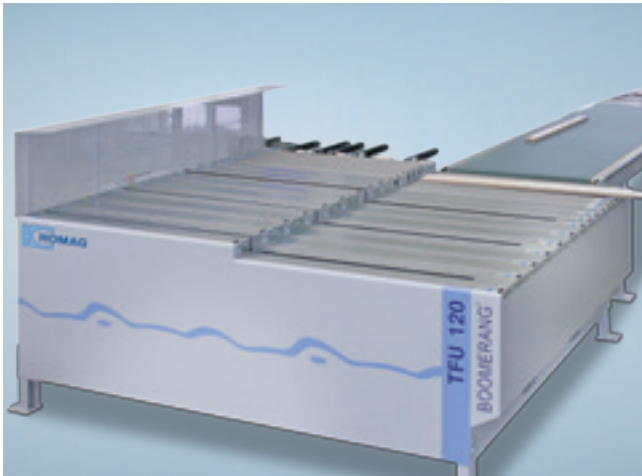

### **BOOMERANG® TFU 120 – excellently suited for small, narrow, and medium-sized workpieces**

- Fast amortization – pays off from 9 hours working time per week
- No training required – simply set up, connect and BOOMERANG® is ready to go
- Flexible operator organization – thanks to economic one-man operation
- Ergonomic working – manual parts handling is reduced to a minimum
- Improved quality control – rapid response to material adjustments



### **BOOMERANG® TFU 140/20 – best suited for high material variety, from small and light up to large and heavy workpieces**

- Fast amortization – pays off from 15 hours working time per week
- Low quality costs – gentle workpiece handling with air cushion table
- No training required – simply set up, connect and BOOMERANG® is ready to go
- Flexible operator organization – thanks to economic one-man operation
- Ergonomic operation – operator will be released from heavy physical work

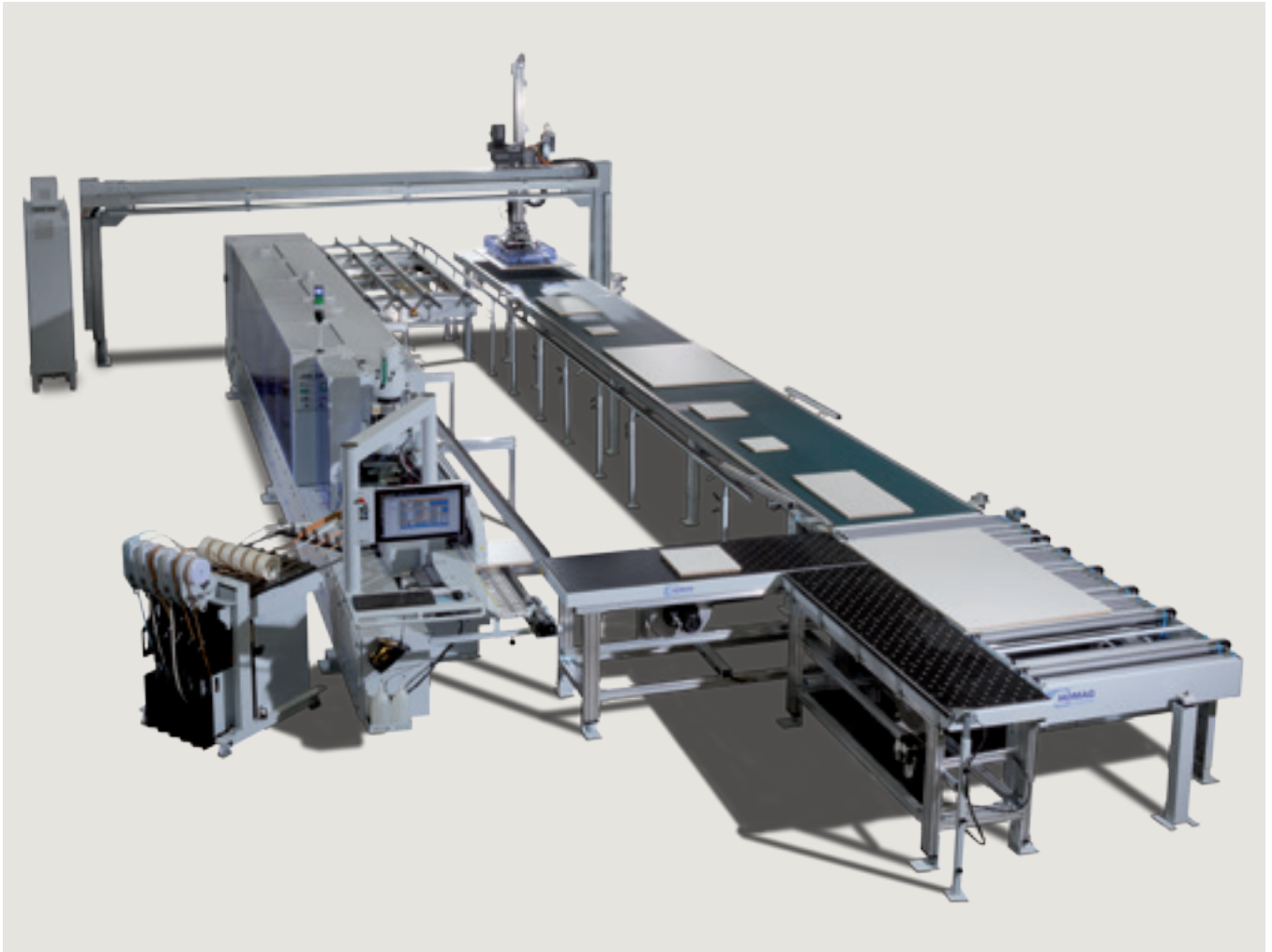

### BOOMERANG® TFU 521 edition

The high automation degree makes the return conveyor BOOMERANG® TFU 521 edition a real multi-talent. Finished workpieces can be fed out or stacked.

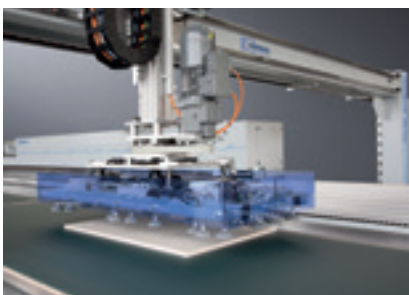

### Integrated workpiece handling with TFU 521 edition

- Interlinked material flow with high output
- Defined panel turning for process oriented workpiece return
- Gentle workpiece handling with vacuum traverse
- Economic single person operation
- Operator will be released from heavy physical work

## BENEFITS

- Minimal quality costs
- Flexible staffing organization
- Ergonomic operation
- Smart automation
- Increased efficiency

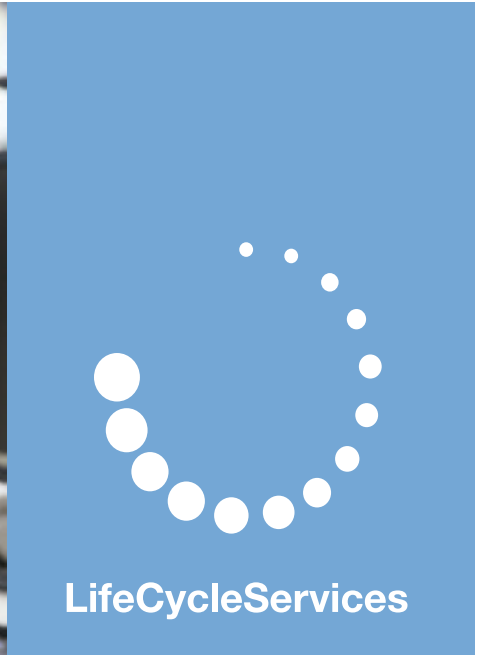

## HOMAG Life Cycle Services

The sale of our machines comes with all-in optimum service backup and individual advice. We support you with service innovations and products which are specially tailored to your requirements.

With short response times and fast customer solutions we guarantee consistently high availability and economical production – over the entire life cycle of your machine.



### Remote Service

- Hotline Support by remote diagnostics for control systems, mechanics and process technology, resulting in 85.2 % fewer on-site servicing callouts
- Mobile applications such as ServiceBoard reduce costs due to rapid assistance in case of faults using mobile live video diagnostics and the online spare parts shop eParts



### Spare Part Service

- Round-the-clock identification, inquiries and direct ordering of spare parts at [www.eParts.de](http://www.eParts.de)
- Local availability of parts through sales and servicing companies and partners the world over
- Reduced downtimes due to defined spare part and wearing part kits



### Modernization

- Keep your machinery up to date and increase your productivity and product quality to prepare yourself today for the product requirements of tomorrow
- We provide support in the form of upgrades, modernization, individual advice and development



**HOMAG Finance**  
**– precisely the right financing**

- We offer tailor-made financing arrangements for your plants and machines. Our advisory service goes hand in hand with our technical expertise over a wide range of issues. Your personal advisor will take care of the complete process
- The benefit for you: The ability to invest without delay in new technologies and remain financially flexible

**1,200**

servicing employees around the world.

**650**

processed spare parts orders per day.

**85.2 %**

fewer on-site service callouts  
 due to successful remote diagnostics.

**>150,000**

machines electronically documented in 28 languages in eParts.



**Training**

- Training tailored precisely to your requirements ensures that the optimum operation and maintenance of your HOMAG machinery by your own machine operators
- Courses include customer-specific training documentation complete with practical training exercises

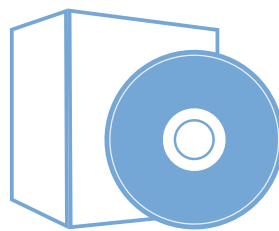

**Software**

- Telephone assistance and advice by Software Support
- Digitalization of your samples by means of 3D scanners saves time and money compared to new programming
- Subsequent networking of your machine outfit using smart software solutions from design through to production



**Field Service**

- Increase of machine availability and product quality by certified service staff
- Assurance of the highest quality of your products by regular checks through maintenance / inspection
- Minimized downtimes due to unpredictable faults due to the ready availability of qualified technicians



## The convenient machine for your requirements: Technical data overview

The machines from the 1600 to 2600 series offer comprehensive solutions to manufacture your products flexible and economical. Whether living room, bedroom and kitchen furniture, functional office furniture, superior shopfitting solutions or batch size 1 production for individual

requirements — HOMAG offers a well designed product range to meet any requirement. Using these machines can also make current trends easily achievable for you and your employees.

The following technical data give a detailed overview.



Image sources: Kettaker GmbH & Co. KG (living room), Fotolia (kitchen and bathroom)

**TECHNICAL DATA AMBITION 1600 SERIES**

MACHINE DIMENSIONS	AMBITION 1650 FC	AMBITION 1660 FGC	AMBITION 1660 FSC	AMBITION 1670 FSCG
<b>Overall length (mm)</b>	5,760	6,260	6,260	6,760
<b>Working height (mm)</b>	950	950	950	950
<b>WORKING DIMENSIONS</b>				
<b>Workpiece width (mm)</b>				
with workpiece thickness 8 – 22 mm	70	70	70	70
with workpiece thickness 23 – 40 mm	120	120	120	120
with workpiece thickness 41 – 60 mm	150	150	150	150
<b>Workpiece thickness (mm)</b>	8 – 60	8 – 60	8 – 60	8 – 60
<b>Edge thickness, coils (mm)</b>	0.4 – 3	0.4 – 3	0.4 – 3	0.4 – 3
<b>Edge thickness, strips / solid strips (mm)</b>	0.4 – 12	0.4 – 12	0.4 – 12	0.4 – 12
<b>MISCELLANEOUS</b>				
<b>Feed speed (m/min)</b>	8 – 18 (optional 20)	8 – 18 (optional 20)	8 – 18 (optional 20)	8 – 18 (optional 20)
<b>Weight (kg)</b>	2,600	3,000	3,000	3,400
<b>Pneumatic system (bar)</b>	6	6	6	6
<b>Electrics</b>	for public power supply all over the world			

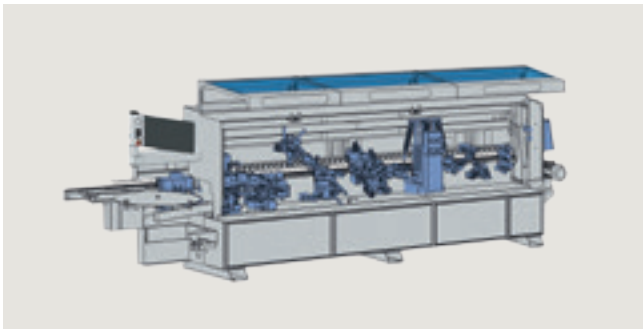

**Ambition 1650 FC**

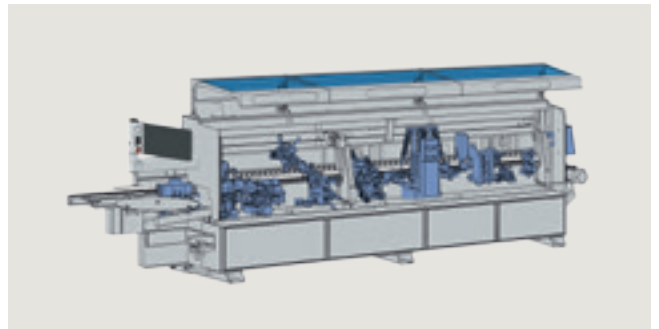

**Ambition 1660 FGC**

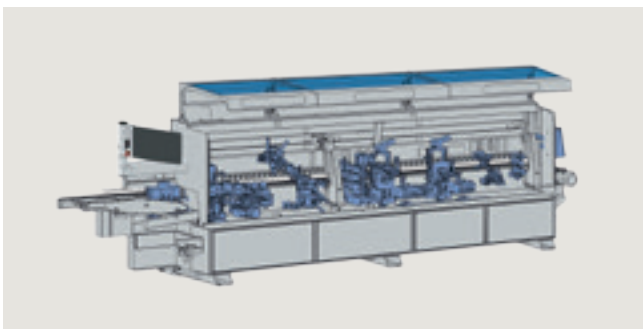

**Ambition 1660 FSC**

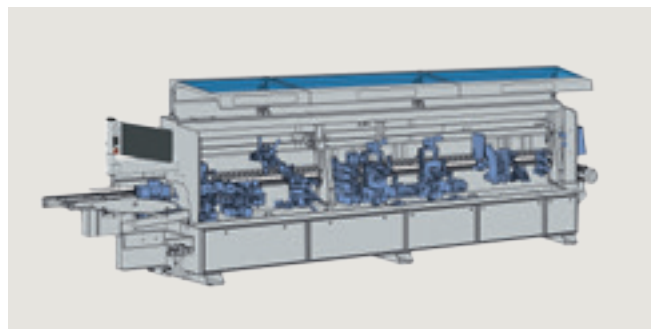

**Ambition 1670 FSCG**



**TECHNICAL DATA AMBITION 1600 SERIES**

MACHINE DIMENSIONS	HIGHFLEX 1650	HIGHFLEX 1660	AMBITION 1650 AIRTEC	KDF 650 EDITION
<b>Overall length (mm)</b>	5,760	6,260	6,060	6,060
<b>Working height (mm)</b>	950	950	950	950
<b>WORKING DIMENSIONS</b>				
<b>Workpiece width (mm)</b>				
with workpiece thickness 8 – 22 mm	70	70	70	70
with workpiece thickness 23 – 40 mm	120	120	120	120
with workpiece thickness 41 – 60 mm	150	150	150	150
<b>Workpiece thickness (mm)</b>	8 – 60	8 – 60	8 – 60	8 – 60
<b>Edge thickness, coils (mm)</b>	0.4 – 3	0.4 – 3	0.4 – 3	0.4 – 3
<b>Edge thickness, strips / solid strips (mm)</b>	0.4 – 15	0.4 – 15	0.4 – 12	0.4 – 12
<b>MISCELLANEOUS</b>				
<b>Feed speed (m/min)</b>	8 – 18	8 – 18	8 – 20	8 – 20
<b>Weight (kg)</b>	2,600	3,000	2,600	2,600
<b>Pneumatic system (bar)</b>	6	6	6	6
<b>Electrics</b>	for public power supply all over the world			

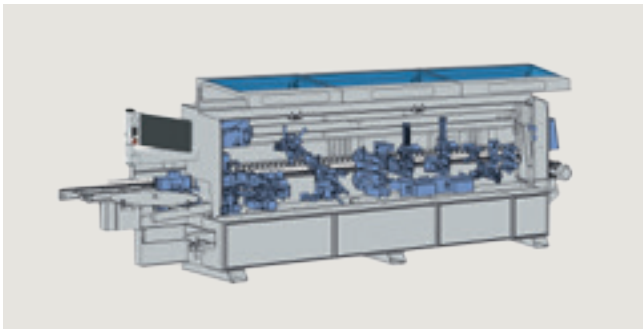

**Highflex 1650**

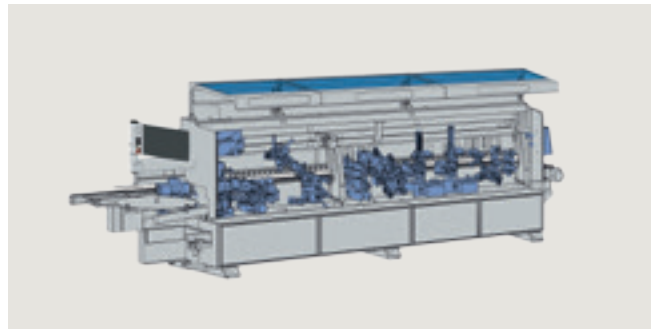

**Highflex 1660**

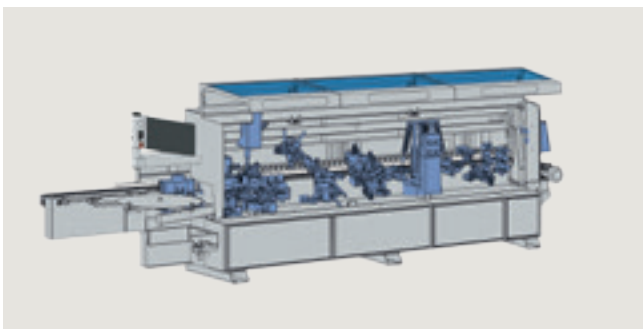

**Ambition 1650 airTec**

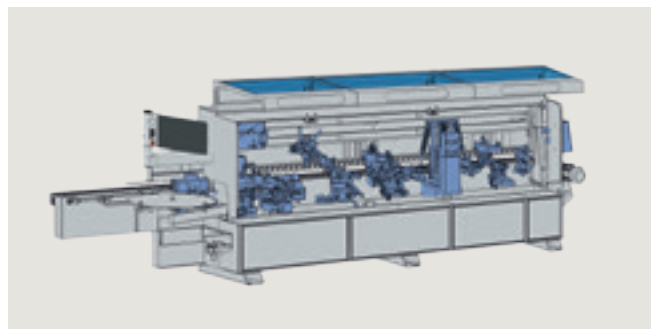

**KDF 650 Edition**

**TECHNICAL DATA AMBITION 1800 SERIES**

MACHINE DIMENSIONS	AMBITION 1870 FSC	AMBITION 1880 FSCU	AMBITION 1880 FGC
Overall length (mm)	6,760	7,260	7,260
Working height (mm)	950	950	950
WORKING DIMENSIONS			
Workpiece width (mm)			
with workpiece thickness 8 – 22 mm	70	70	70
with workpiece thickness 23 – 40 mm	120	120	120
with workpiece thickness 41 – 60 mm	150	150	150
Workpiece thickness (mm)	8 – 60	8 – 60	8 – 60
Edge thickness, coils (mm)	0.4 – 3	0.4 – 3	0.4 – 3
Edge thickness, strips / solid strips (mm)	0.4 – 12	0.4 – 12	0.4 – 12
MISCELLANEOUS			
Feed speed (m/min)	8 – 20	8 – 20	8 – 20
Weight (kg)	3,400	3,600	3,600
Pneumatic system (bar)	6	6	6
Electrics	for public power supply all over the world		

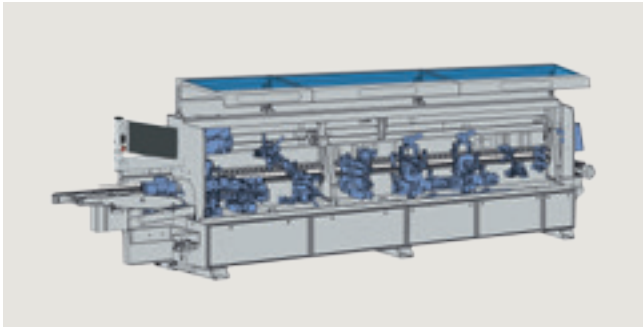

Ambition 1870 FSC

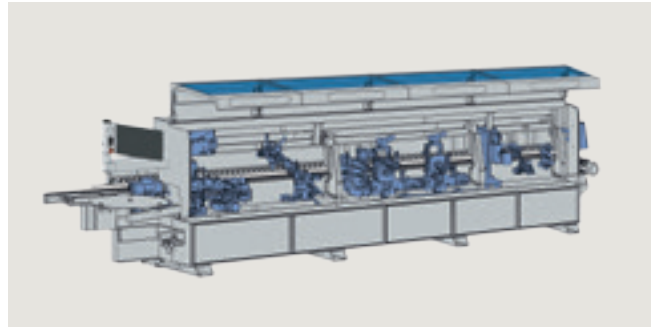

Ambition 1880 FSCU

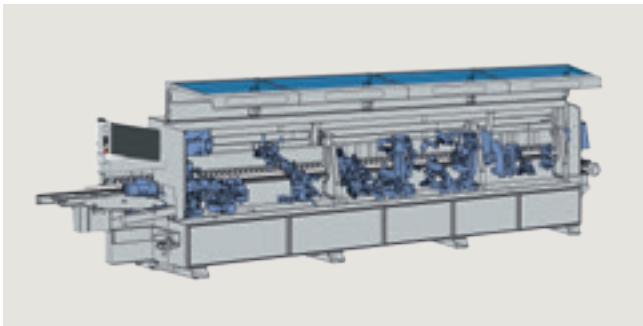

Ambition 1880 FGC

**TECHNICAL DATA AMBITION 1800 SERIES**

MACHINE DIMENSIONS	HIGHFLEX 1870	HIGHFLEX 1880	AMBITION 1860 AIRTEC	KDF 860 EDITION
<b>Overall length (mm)</b>	6,760	7,260	6,560	6,560
<b>Working height (mm)</b>	950	950	950	950
<b>WORKING DIMENSIONS</b>				
<b>Workpiece width (mm)</b>				
with workpiece thickness 8 – 22 mm	70	70	70	70
with workpiece thickness 23 – 40 mm	120	120	120	120
with workpiece thickness 41 – 60 mm	150	150	150	150
<b>Workpiece thickness (mm)</b>	8 – 60	8 – 60	8 – 60 (8 – 40 with airTec)	8 – 60
<b>Edge thickness, coils (mm)</b>	0.4 – 3	0.4 – 3	0.4 – 3	0.4 – 3
<b>Edge thickness, strips / solid strips (mm)</b>	0.4 – 12	0.4 – 15	0.4 – 12	0.4 – 12
<b>MISCELLANEOUS</b>				
<b>Feed speed (m/min)</b>	8 – 20	8 – 20	8 – 20	8 – 20
<b>Weight (kg)</b>	3,400	3,600	3,000	3,000
<b>Pneumatic system (bar)</b>	6	6	6	6
<b>Electrics</b>	for public power supply all over the world			

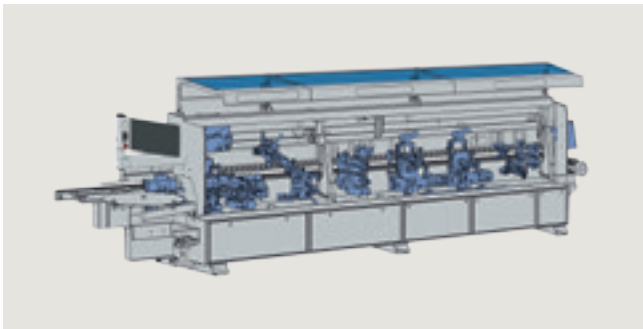

**Highflex 1870**

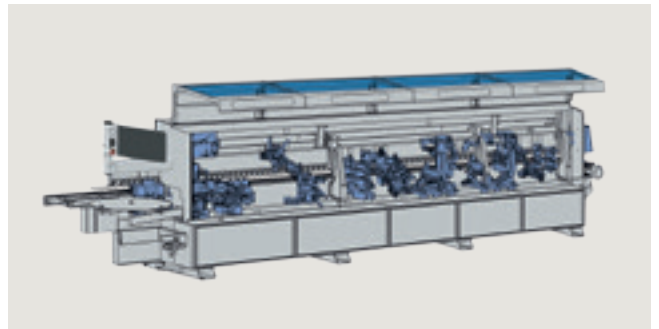

**Highflex 1880**

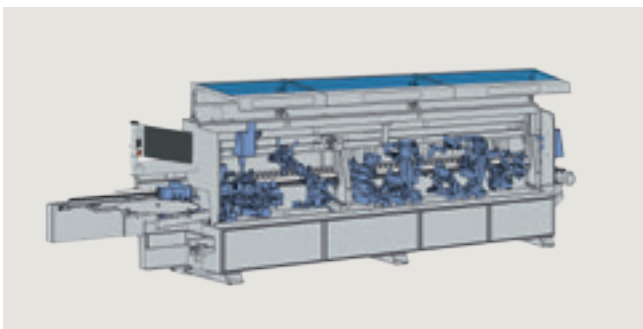

**Ambition 1860 airTec**

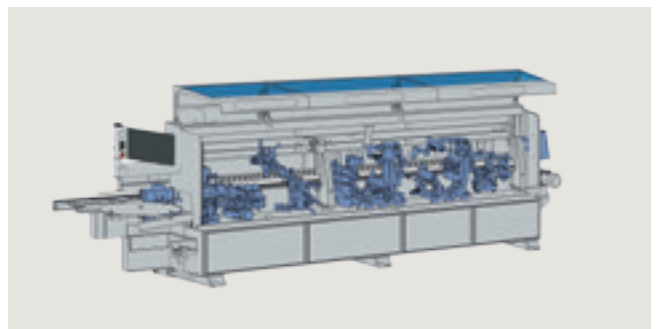

**KDF 860 Edition**

### TECHNICAL DATA AMBITION 2200 SERIES

MACHINE DIMENSIONS	AMBITION 2270	AMBITION 2280	AMBITION 2274	AMBITION 2284
Overall length (mm)	8,365	9,365	8,365	9,365
Working height (mm)	950	950	950	950
<b>WORKING DIMENSIONS</b>				
Workpiece width (mm)				
with workpiece thickness 12 – 22 mm	min. 60, dependent on workpiece length			
with workpiece thickness 23 – 40 mm	min. 105, dependent on workpiece length			
Workpiece thickness (mm)	8 – 60	8 – 60	8 – 60	8 – 60
Edge thickness, coils (mm)	0.3 – 3	0.3 – 3	0.3 – 3	0.3 – 3
Edge thickness, strips / solid strips (mm)	optional 0.3 – 1 / 0.6 – 20	optional 0.3 – 1 / 0.6 – 20	optional 0.3 – 1 / 0.6 – 20	optional 0.3 – 1 / 0.6 – 20
<b>MISCELLANEOUS</b>				
Feed speed (m/min)	16 – 20	16 – 20	16 – 20	16 – 20
Weight (kg)	4,000	4,500	4,000	4,500
Pneumatic system (bar)	6	6	6	6
Electrics	for public power supply all over the world			

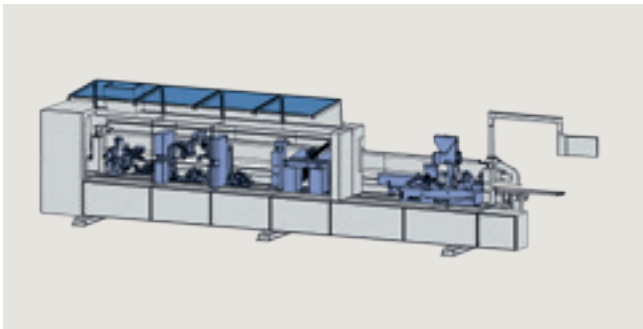

Ambition 2270

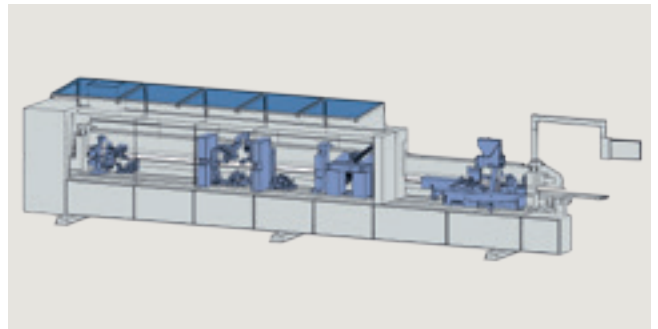

Ambition 2280

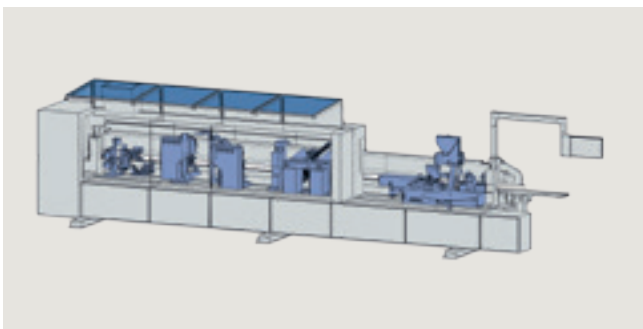

Ambition 2274

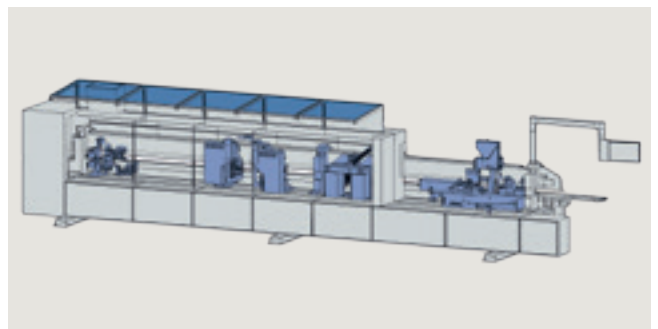

Ambition 2284

**TECHNICAL DATA AMBITION 2400 SERIES**

MACHINE DIMENSIONS	AMBITION 2470	AMBITION 2480	AMBITION 2474	AMBITION 2484
Overall length (mm)	8,365	9,365	8,365	9,365
Working height (mm)	950	950	950	950
<b>WORKING DIMENSIONS</b>				
Workpiece width (mm)				
with workpiece thickness 12 – 22 mm	min. 60, dependent on workpiece length			
with workpiece thickness 23 – 40 mm	min. 105, dependent on workpiece length			
Workpiece thickness (mm)	8 – 60	8 – 60	8 – 60	8 – 60
Edge thickness, coils (mm)	0.3 – 3	0.3 – 3	0.3 – 3	0.3 – 3
Edge thickness, strips / solid strips (mm)	optional 0.3 – 1 / 0.6 – 20	optional 0.3 – 1 / 0.6 – 20	optional 0.3 – 1 / 0.6 – 20	optional 0.3 – 1 / 0.6 – 20
<b>MISCELLANEOUS</b>				
Feed speed (m/min)	16 – 25	16 – 25	16 – 25	16 – 25
Weight (kg)	4,000	4,500	4,000	4,500
Pneumatic system (bar)	6	6	6	6
Electrics	for public power supply all over the world			

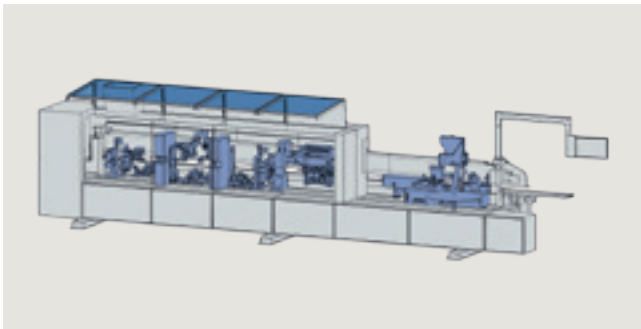

Ambition 2470

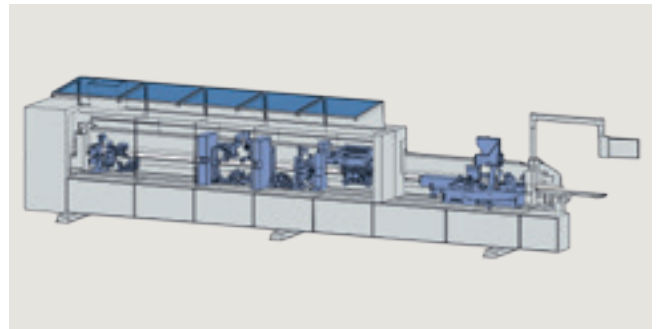

Ambition 2480

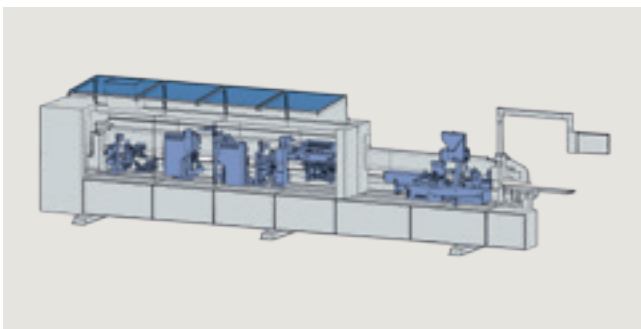

Ambition 2474

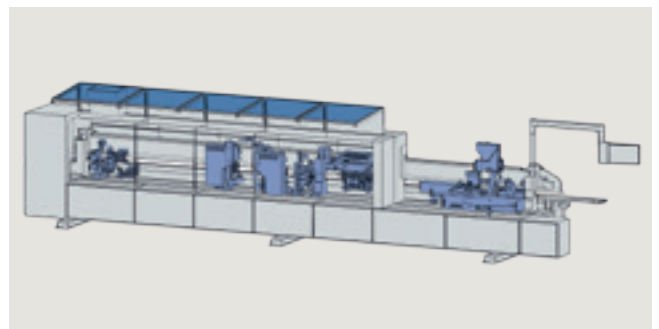

Ambition 2484

**TECHNICAL DATA AMBITION 2400 SERIES**

<b>MACHINE DIMENSIONS</b>	<b>AMBITION 2482</b>	<b>AMBITION 2492</b>
<b>Overall length (mm)</b>	9,365	10,365
<b>Working height (mm)</b>	950	950
<b>WORKING DIMENSIONS</b>		
<b>Workpiece width (mm)</b>		
with workpiece thickness 12 – 22 mm	min. 60, dependent on workpiece length	
with workpiece thickness 23 – 40 mm	min. 105, dependent on workpiece length	
<b>Workpiece thickness (mm)</b>	8 – 60	8 – 60
<b>Edge thickness, coils (mm)</b>	0.3 – 3	0.3 – 3
<b>Edge thickness, strips / solid strips (mm)</b>	optional 0.3 – 1 / 0.6 – 20	optional 0.3 – 1 / 0.6 – 20
<b>MISCELLANEOUS</b>		
<b>Feed speed (m/min)</b>	16 – 25	16 – 25
<b>Weight (kg)</b>	4,500	5,000
<b>Pneumatic system (bar)</b>	6	6
<b>Electrics</b>	for public power supply all over the world	

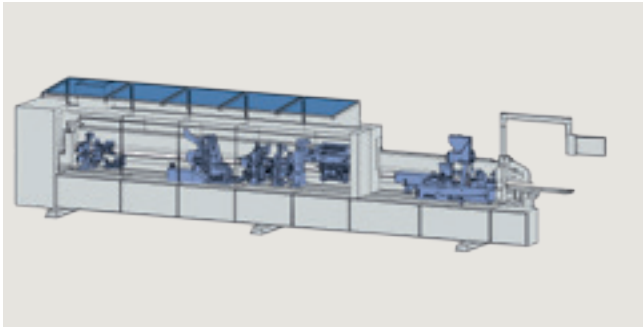
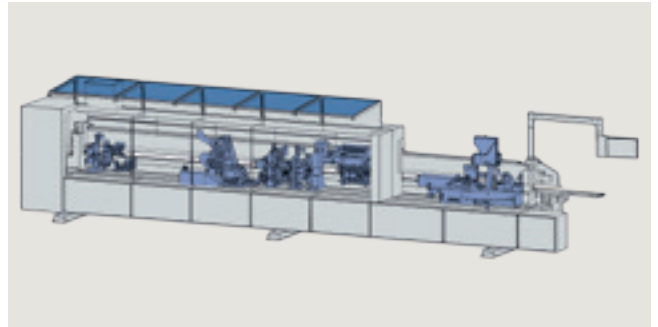
**Ambition 2482****Ambition 2492**

**TECHNICAL DATA AMBITION 2600 SERIES**

MACHINE DIMENSIONS	AMBITION 2660	AMBITION 2670	AMBITION 2671
Overall length (mm)	7,365	8,365	8,365
Working height (mm)	950	950	950
<b>WORKING DIMENSIONS</b>			
Workpiece width (mm)			
with workpiece thickness 12 – 22 mm	min. 60, dependent on workpiece length		
with workpiece thickness 23 – 40 mm	min. 105, dependent on workpiece length		
Workpiece thickness (mm)	8 – 60	8 – 60	8 – 60
Edge thickness, coils (mm)	0.3 – 3	0.3 – 3	0.3 – 3
Edge thickness, strips / solid strips (mm)	optional 0.3 – 1 / 0.6 – 20	optional 0.3 – 1 / 0.6 – 20	optional 0.3 – 1 / 0.6 – 20
<b>MISCELLANEOUS</b>			
Feed speed (m/min)	16 – 28	16 – 28	16 – 30
Weight (kg)	3,500	4,000	4,000
Pneumatic system (bar)	6	6	6
Electrics	for public power supply all over the world		

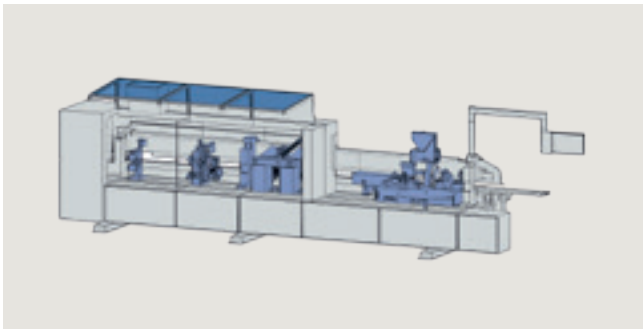

Ambition 2660

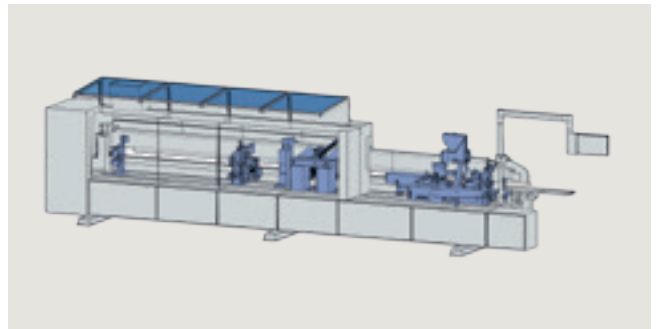

Ambition 2670

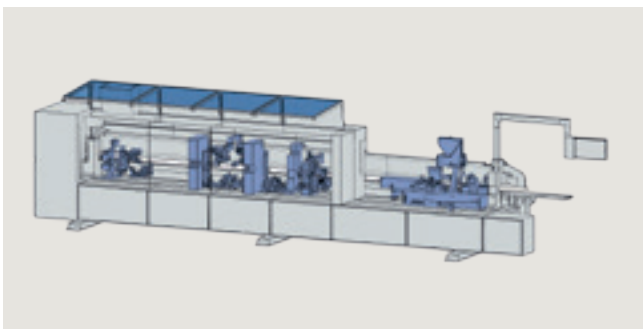

Ambition 2671

**HOMAG GmbH**

Homagstraße 3-5  
72296 Schopfloch  
Germany  
Tel. +49 7443 130  
info@homag.com  
www.homag.com

