

A good “Grip” on Window Production.

HOMAG

CNC processing centres
CENTATEQ S-800|900

YOUR SOLUTION

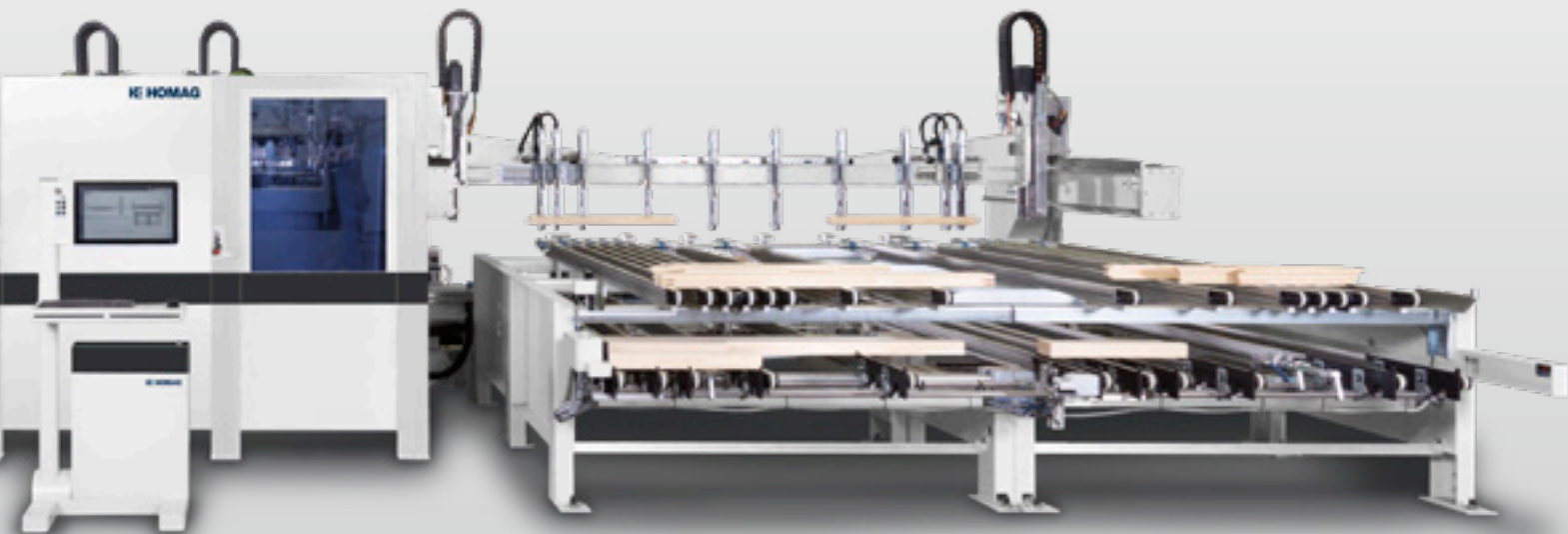

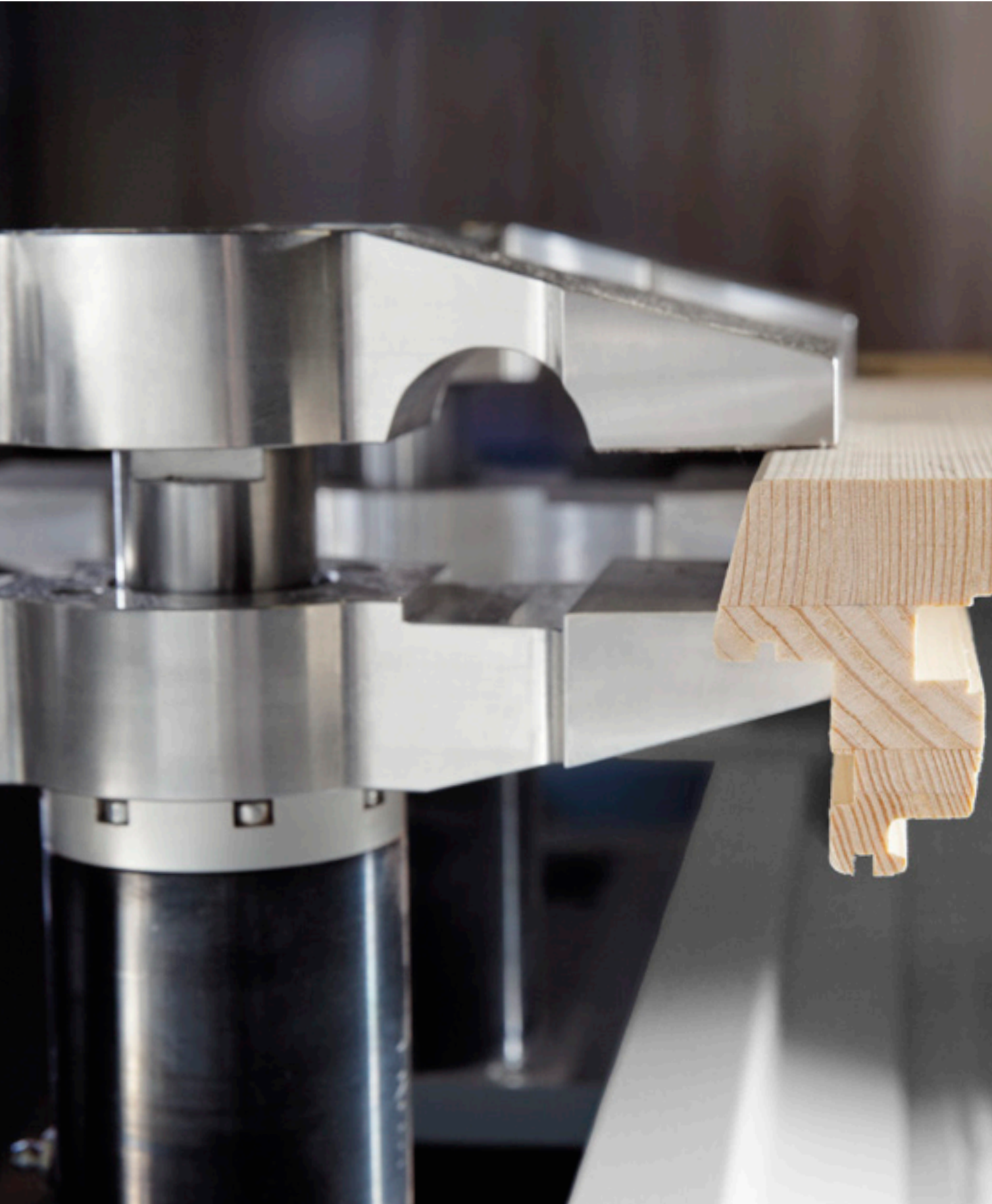

Fit for the future, flexible for everyday life.

Much has changed in terms of producing windows and doors. New customer requirements, different materials, improved insulation — to continue to be able to meet all your production needs in the future, you need a partner who also continues to develop. At HOMAG, you can be sure that our machines are constantly being developed; not to mention, they already fulfil the requirements of tomorrow.

YOUR SOLUTION

[MORE: HOMAG.COM](https://www.homag.com)



CENTATEQ S-800|900

Content

- 04 20 years' experience
- 06 Requirements for window construction
- 08 At a glance
- 10 Gripping and clamping technology
- 14 Spindles, units, tool changers
- 18 Profile splitting technique
- 22 Additional functions and options
- 24 Scalable performance
- 26 Solutions tailored to your production
- 28 Software/control
- 30 Life Cycle Services

What makes HOMAG future-oriented? Over 20 years of experience!

It is now impossible to imagine window production without CNC technology. For more than 20 years, HOMAG has developed CNC machines for window construction that have revolutionized window processing. Today, it is possible to complete the entire processing process in just a single step

with maximum precision and outstanding quality. You will benefit from partially and fully automatic solutions, allowing the production of up to 100 window units per shift. And of course, HOMAG offers solutions for all components and designs, leaving no customer wish unfulfilled.



Clamping systems for window production: Clamping systems specially optimized for window production, such as the 3-stage clamp with a large clamping height for precise, complete processing of window and door parts without subsequent rabbeting.



High-performance spindles and independent operation: High performance by means of simultaneous processing on both tables and liquid-cooled spindles with vector control.

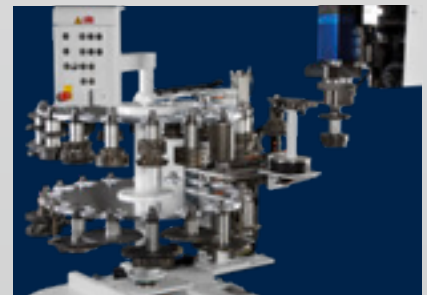

Tool changing system: Tool changers with high capacity and short change times are the basis for operational flexibility and high productivity.



Bespoke core components: The HOMAG develops and manufactures the core components for CNC technology itself.

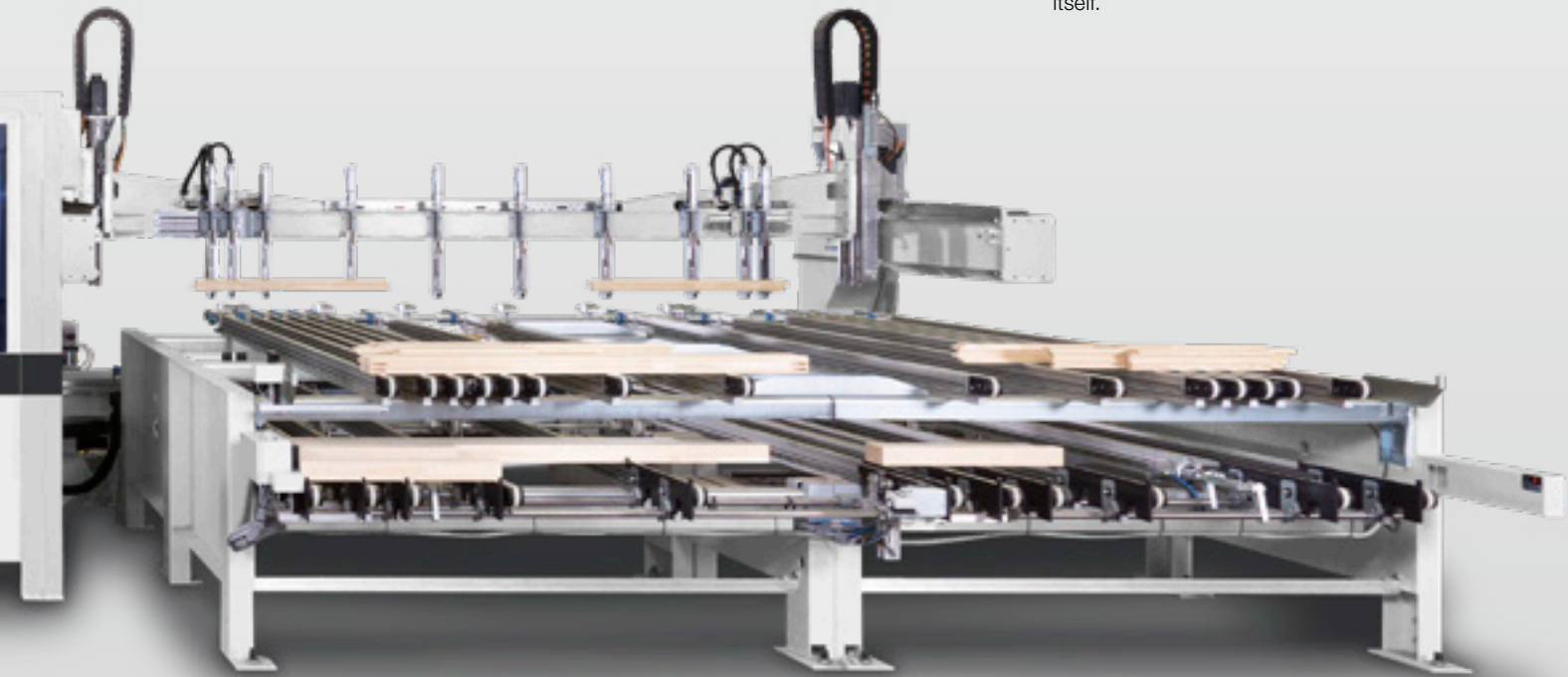

CENTATEQ S-900: Processing centers for the automated window production from entry to whole plant concepts for industrial multiple shift operation. Autonomous processing by automatic feeding and removal of the parts. Furthermore curved parts and surface parts can be processed. One machine for all components.

We do not shy away from complex requirements — we find solutions.

Even products which at first glance do not appear to undergo any changes, may actually require several. This also changes the requirements put on the manufacturer. Whether it is windows with slim optics and thus new profile geometries that are popular, whether a greater variety of products requires an increased range of components, or new hardware and additional elements require further processing

steps — you need machines that keep pace with this development. The products that you manufacture are also becoming more complex: whether dowels, pins or corner connections, whether fixtures, fans, openings, and cut-outs — you need to be prepared for every feature so that you can manufacture the precise windows that are required.

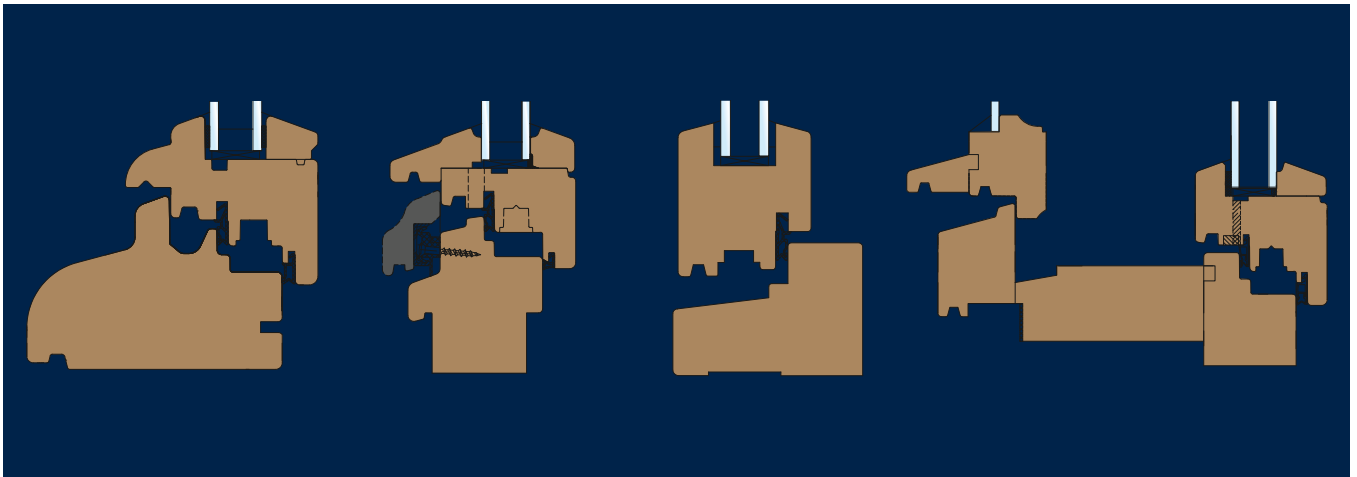

System diversity: Different climate zones, legal requirements and traditions are reflected in a vast variety of window systems worldwide. This poses no problem with HOMAG CNC technology and the experience of our window specialists

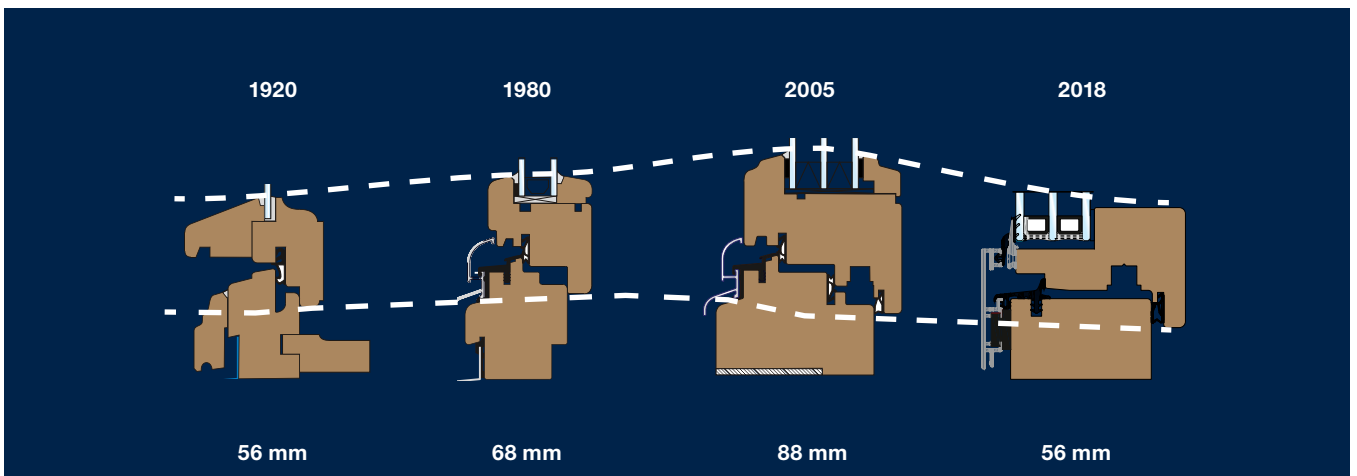

„Slim Fit“ for windows: Back to their origins: view widths are becoming narrower again, cross-sections slimmer.

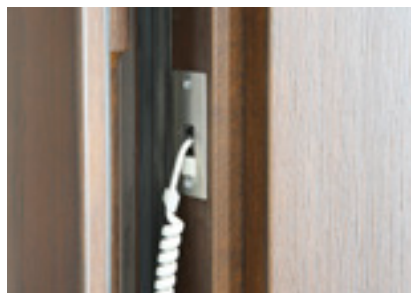
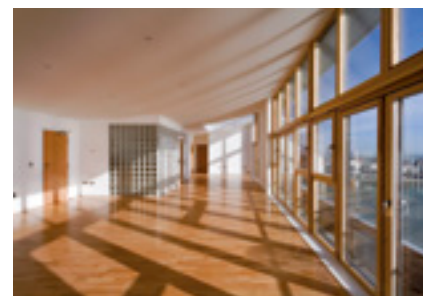

Corner connections: Slot and tenon, dowel, screw, rounded tenon... — which type of corner should it be? HOMAG CNC processing centers give you the choice and are prepared for future trends and developments

Complete processing: No additional operations: thanks to complete machining, CNC technology makes window production economical. Cut-outs and bore holes for recessed locking plates, concealed fixtures, screw marks, fan or cable guides are integrated in CNC precision. What more could you want?

Product variety: More than just windows: The CENTATEQ S even masters doors, conservatories, facades, plus lifting/sliding doors. One machine for everything.

At a glance: CENTATEQ S-800|900.

A GOOD “GRIP” ON EVERYTHING. The new gripping and clamping technology opens up new possibilities for profile design > Future proof for new window systems

HIGH PERFORMANCE IN A SMALL SPACE. Parallel processing of multiple components and fast tool change, loading and removal at one point > Compact space, ergonomic operation, lower investment and operating costs

ALL-IN-ONE MACHINE. Integration of all components: straight parts, curved parts, doors and supplementary elements > One machine, one data interface, one tool set

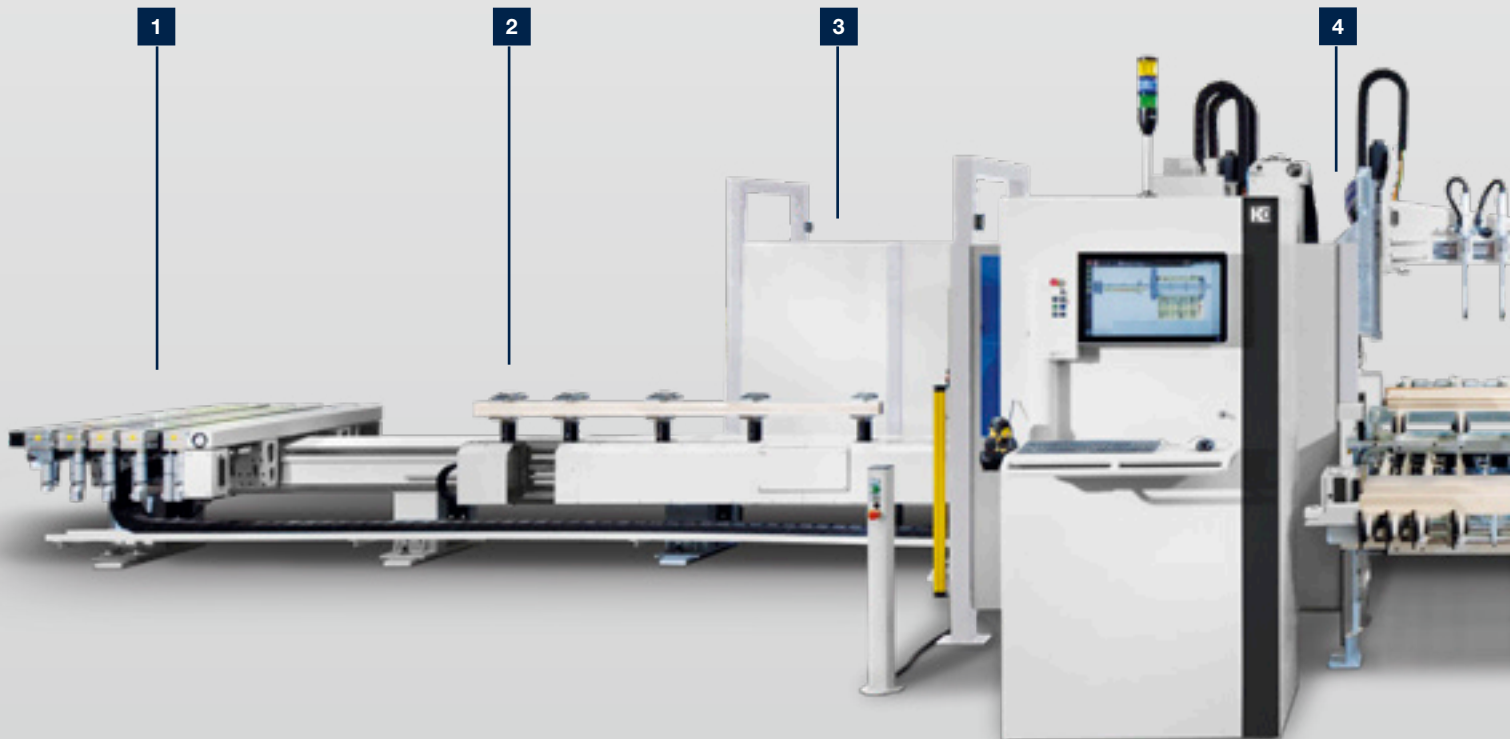

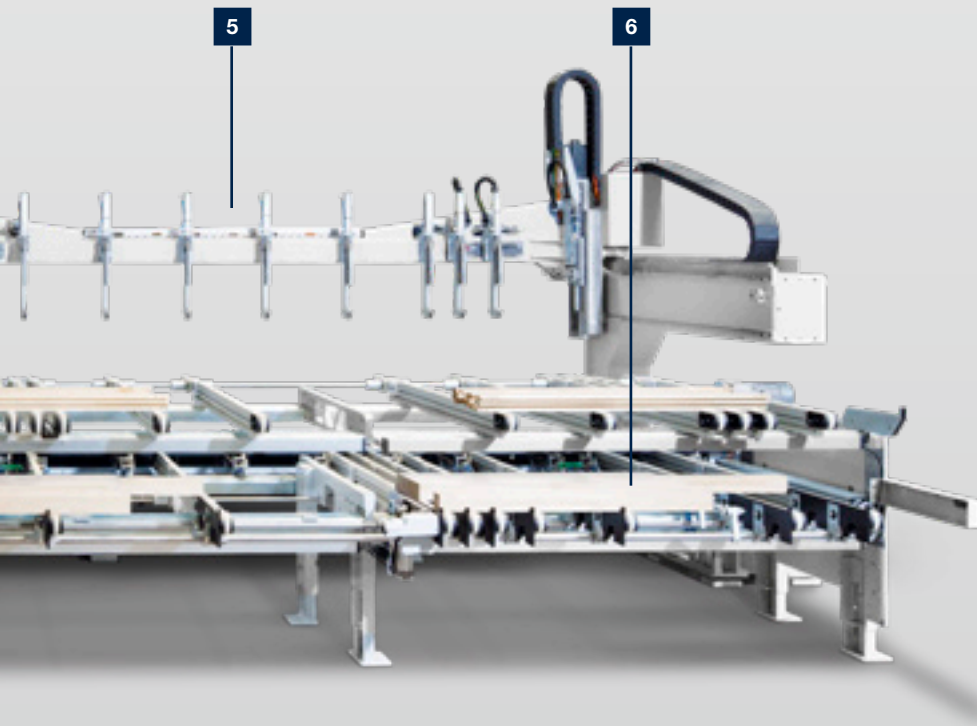

1 Console table: Additional consoles with stop pins for processing curves, doors and other surface parts.

2 Clamping table: Clamping table with programcontrolled, movable, and rotatable clamping elements.

3 Tool changer: High capacity for large and long tools, plus fast tool change thanks to the pre-changing system.

4 Basic machine: Solid gantry bridge, compact and rigid guide track for the clamping tables.

5 Gripping unit: Clamping, reclamping and returning the window scantlings. Precise workpiece handling thanks to the gripper system that pivots on both sides.

6 Infeed and outfeed table: Dual-level infeeds and outfeeds for centralized workpiece handling.



More options! CENTATEQ S-800|900 clamping technology.

Our clamping technology – Your advantage. Flexible processing options and perfect processing results are guaranteed. Always the right position and the right overhang for processing through free clamping in all directions.



A perfect fit: Precise working thanks to the superior gripping and clamping technology.

It is critical that the workpieces are securely gripped during the entire manufacturing process. Therefore, HOMAG offers you a sophisticated gripping and clamping technology that

features precise workpiece handling, great clamping depth and flexible processing options. Suitable for everything from XXS to XXL.

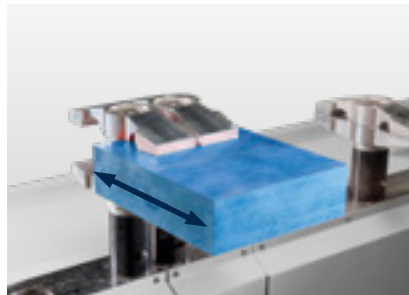

From XXS to XXL: Components from a height of 20 to 150 mm, a width of 25 to 300 mm can be processed in automatic mode. Up to 4 200 mm without, with reclamping 6 000 mm of length is possible in automatic mode.



Dimensional check of unprocessed parts: During placing and clamping unprocessed parts, all the dimensions are checked for plausibility. This prevents the unprocessed parts from accidentally being positioned incorrectly

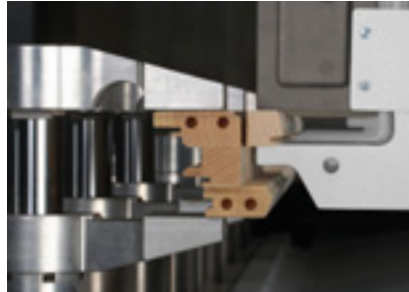

Integrated glass fixing rail: The gripping system also allows production of the glass fixing rail to be integrated. The trimmed rail is broken off and is placed on the outfeed belt. This ensures that all items which are supposed to be kept together actually do remain together.

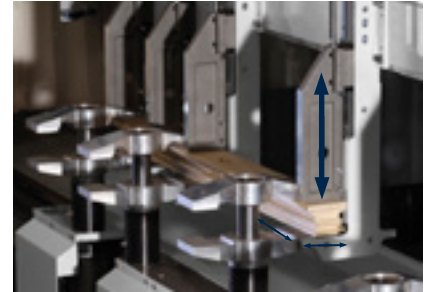

Pivoting clamping plates: The clamping plates can be programmed to swing out to the side. This means that all bore holes and cut-outs can be processed regardless of the position of the clamping elements.



Free clamping: The gripping unit and clamping technology ensure maximum flexibility for processing. The components can be freely clamped in all directions, even while reclamping – freely selectable clamping depth, the clamp can be applied at a position of your choice, even in the rabbet.



Aligning the unprocessed parts: Pressure bolts align the unprocessed part with the insertion table and hold the part in place until the gripper unit picks up the unprocessed part.



Integrated short parts: The clamping and gripping technology also enables the production of very short parts with a balustrade length from 120 mm.

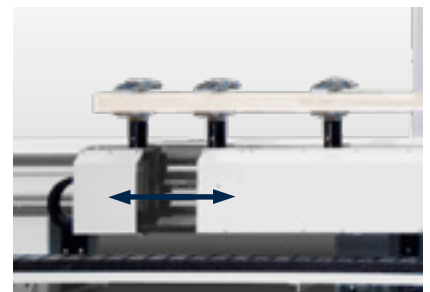

Program-controlled positionable clamping elements: Program-controlled positionable clamping elements and grippers on the handling unit ensure that the workpieces are always held with optimal side overhang.

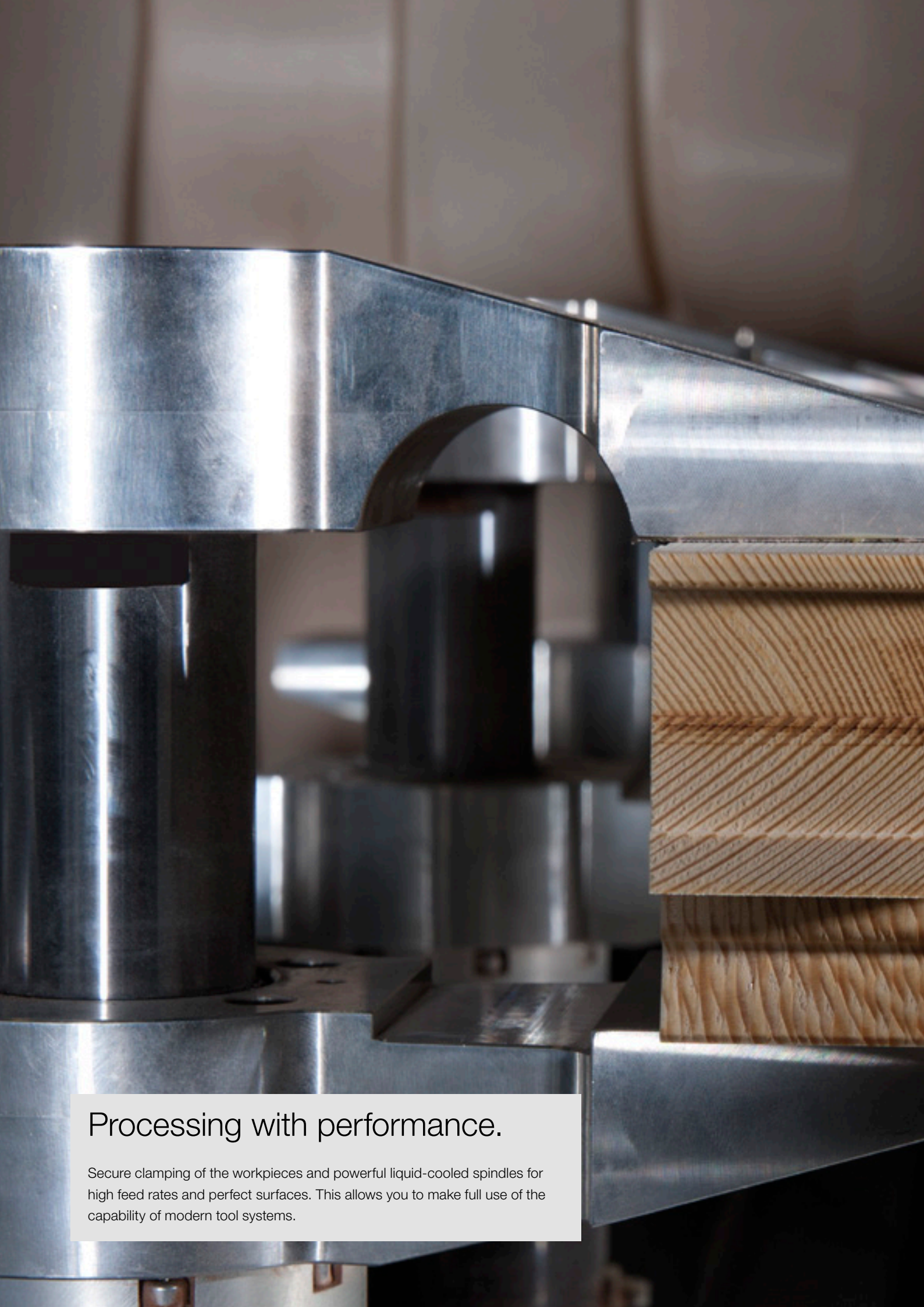

Processing with performance.

Secure clamping of the workpieces and powerful liquid-cooled spindles for high feed rates and perfect surfaces. This allows you to make full use of the capability of modern tool systems.



Prepared for anything: spindles, units, and tool changers

Our impressive spindles feature liquid cooling, a variable speed range, vector control and a spindle sensor that detects imbalances and vibrations, thus protecting the spindle. The proven 5-axis technology or the FLEX5 unit family with exchangeable 5-axis technology, gives you the option of expanding the processing spectrum. What is more, the

compact tool magazine, which is available in various sizes, allows you to remain flexible. The pre-changing system of the central tool magazine provides minimal clamp-to-clamp time, and all tools are located directly within reach of the trimming spindles. The nested arrangement means that all space is efficiently used, even with large tools.

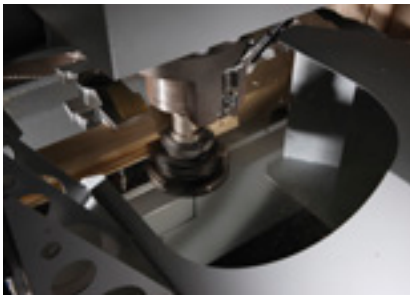

Spindle sensor and chip collection: Hoods that can be steered towards the machine from both sides and a collection of residual pieces under the machine ensure the optimal disposal of chips and cutoffs. The sensor integrated in the spindle detects vibrations caused by imbalance or by inadequate workpiece clamping, thus protecting the spindle.



5-axis technology: DRIVE5 spindles with interpolating fifth axis reduce unit costs and increase flexibility.

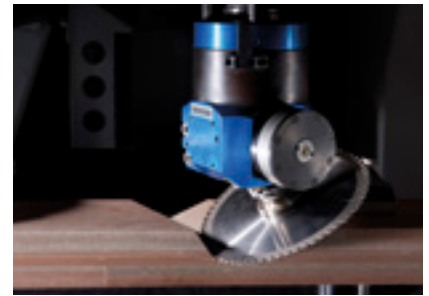

FLEX5 unit technology: Sawing, routing, and drilling at any angle, optionally with automatic tool change. For inclined bore holes, slots, all kind of cuts and connection trimmings.

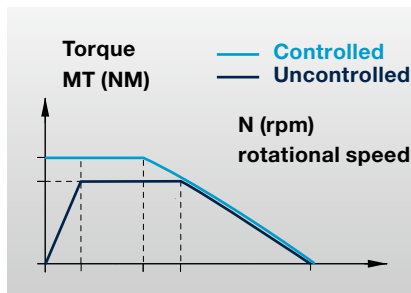

Spindles with vector control: Liquid-cooled spindles with optimized characteristic curve for high torque in the working range and stable running under heavy load by means of a vector controller with encoder return.



Underfloor routing unit: For routing and drilling workpieces from the underside, for example handle cut-outs for lifting/sliding doors without having to turn the workpieces.



Drilling unit 3+1 spindles: Efficient drilling for corners, sash bars and mullions. Multiple bore holes in one cycle using versions with 20 mm or 32 mm grids.

- 1** Tool Management (optional):
- Automatic detection of tools via data chip
 - Synchronization with tool database
 - Avoidance of operating errors

2 Pre-changing system: The next tool is prepared while the machine is working. The actual change only involves reclamping, allowing you to achieve the shortest possible tool change times.

3 Large capacity: The large distance between the chucks means that every available space can be utilized. Nesting allows even large slot and pin tools to be accommodated. Equally, there is also space for twinned, long tools.



Less variety of tools – more output: Profile splitting technology

This enables the efficient use for profile splitting as well as for rough trimming and fine trimming. Instead of two separate trimming passes and two tool changes, now just one is

enough. The tool use becomes more flexible, tool life is increased and trimming quality becomes significantly better.



Efficient profile splitting: Two trimming spindles mounted on one carrier which can be adjusted via NC. This allows profile splitting even for short parts or rough hogging and finish trimming.



Simultaneous tool change: Both spindles are assigned to a 36 or 72-slot tool changer with pre-changing system. In addition, tools can be inserted in the trimming spindles simultaneously.

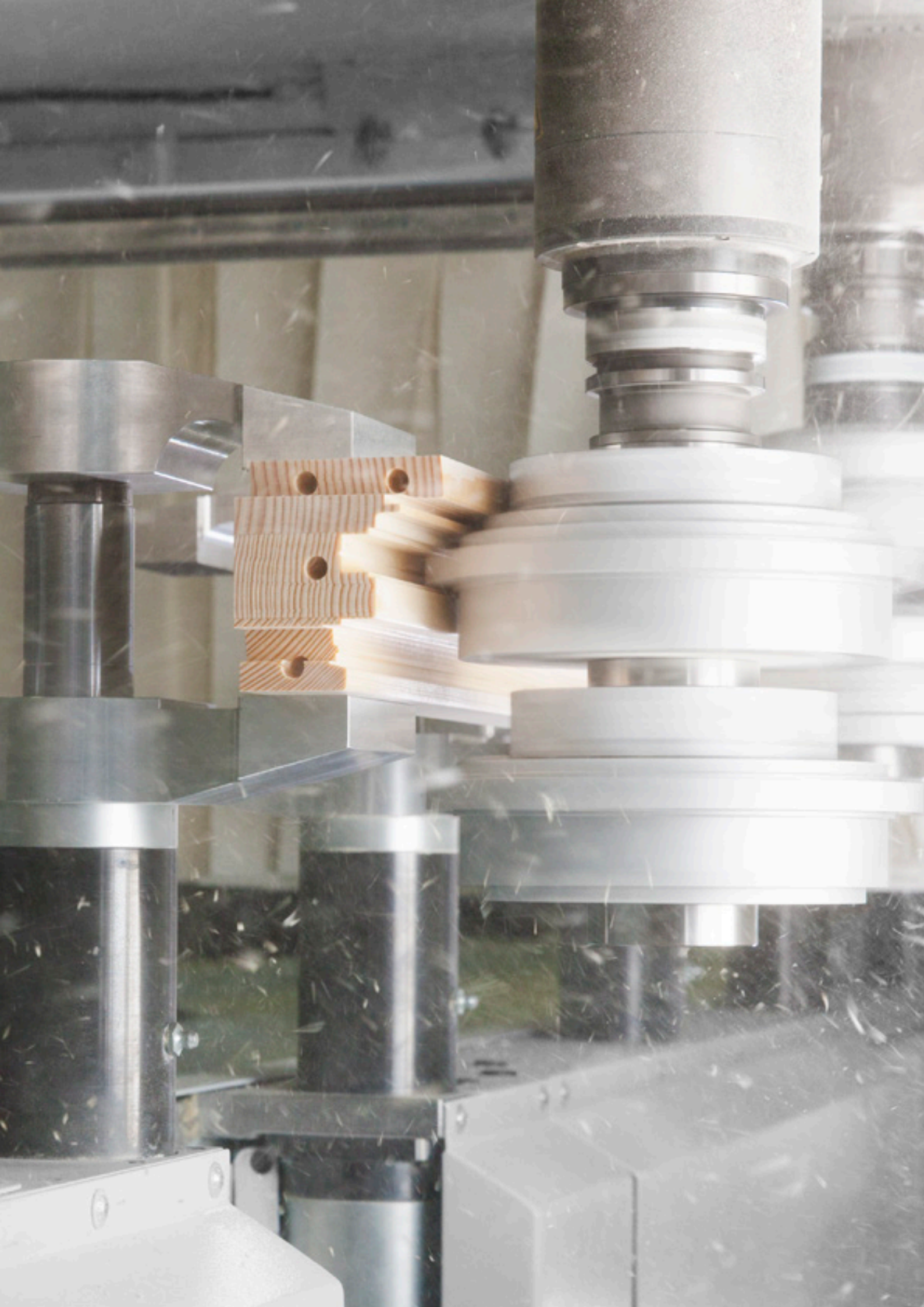

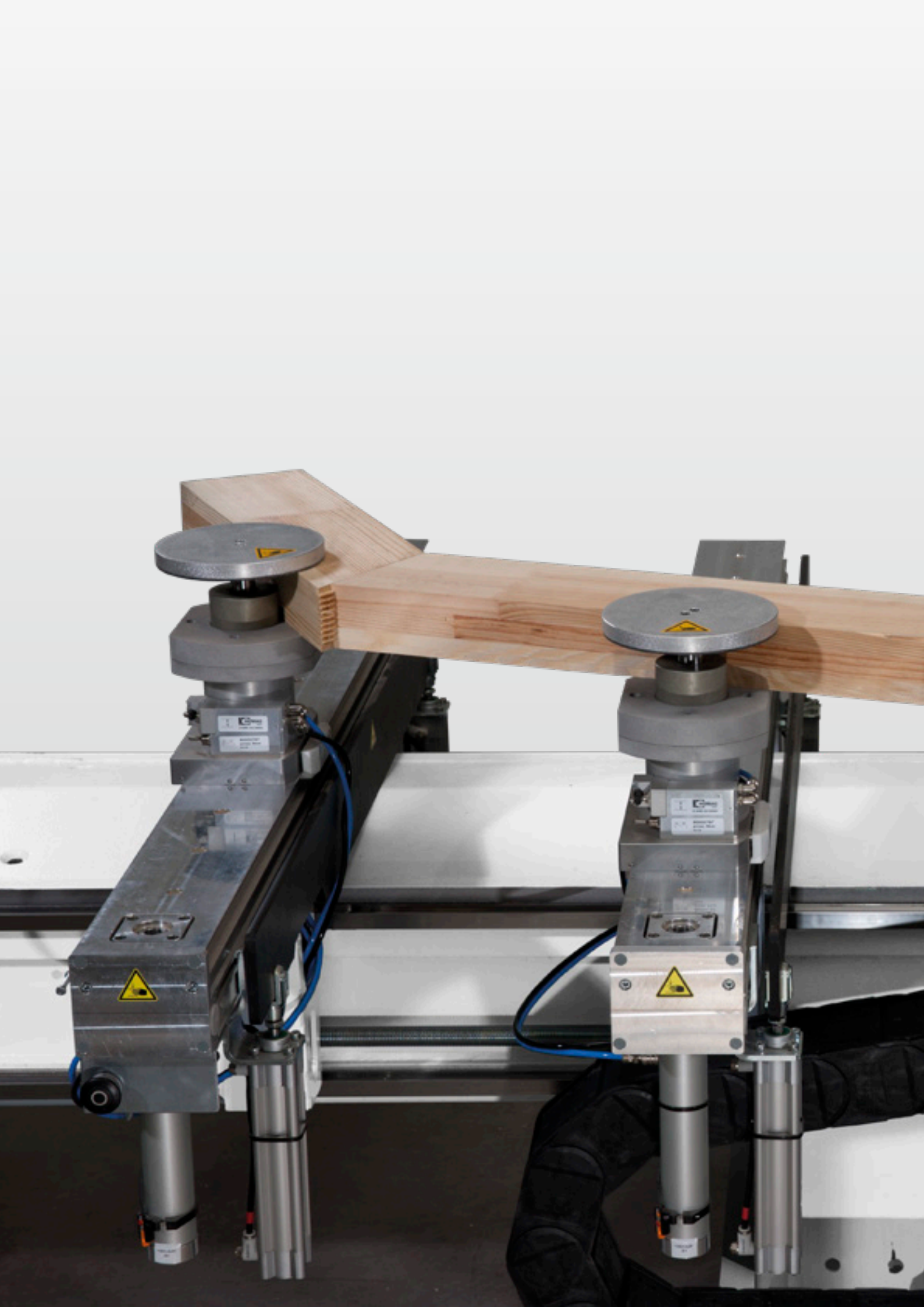

Everything in one machine

Arches, doors and supplementary elements. You do not need a second machine, a table is enough! An extension to a complete system with all possibilities of a common CNC processing center.



More than just straight parts

Are you looking for a solution for arches, doors and special parts? Then the additional table is exactly right for you. Consoles with stop pins turn the Centateq S into a fully fledged CNC machining center. One machine, one data interface, one tool set.



Arches: The complete processing of curved elements with a pitch of up to 1300 mm in one piece reduces production times and manual effort (there is no need to plaster any joints). Of course, this is inclusive of the appropriate glass fixing rail

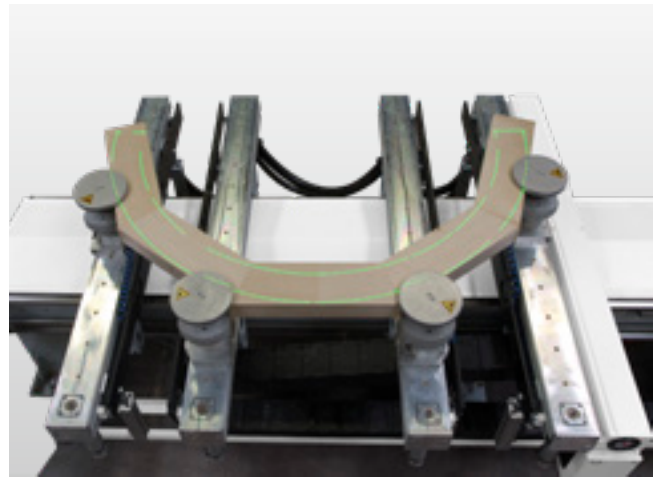

Projection laser: So that unprocessed material is optimally utilized and securely positioned, the clamping elements and the unprocessed parts are aligned for curve processing with the help of a projection laser.



Doors: The complete processing of front door panels for independence and creative design possibilities.



Fillings: Fillings, trims and additional surface elements

Options.

Additional options allow you to strategically expand functionality and convenience.



Ascending conveyor for chips and cutoffs: Waste pieces from the collecting channel under the machine can be fed directly into a container or cart via an ascending conveyor.

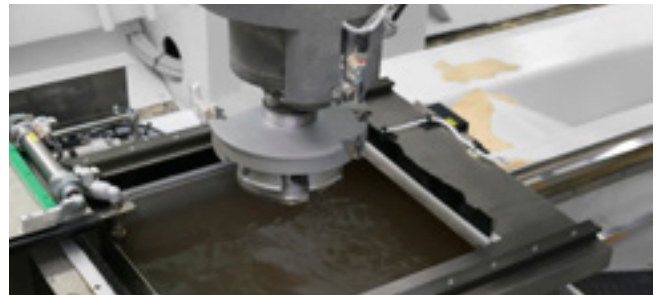

Tool cleaning system: Clean tools overnight. The ultrasonic cleaning device integrated into the machine allows tools to be cleaned without manual intervention. This simplifies exchanging the cutting disks and provides a long service life with high surface quality.

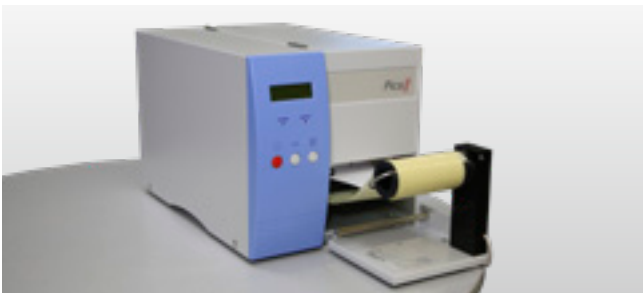

Label printer: Part tracking made easy: A printer at the outfeed allows labels to be directly generated in the correct sequence as the parts are removed

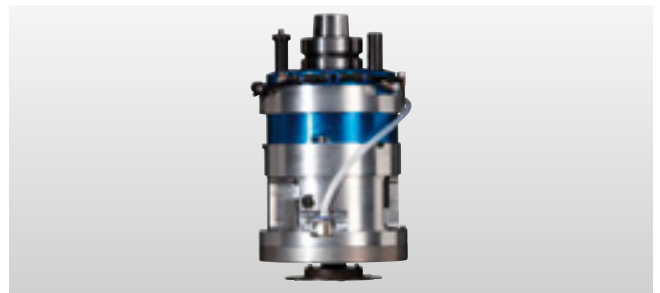

Vertically traced trimming unit: A variety of units can be used and also retrofitted to expand the functional scope of the machines. For example, for sanding or traced trimming of decorative grooves in house doors.

Scalable performance from the entry-level solution CENTATEQ S-800 to high-performance configuration CENTATEQ S-900.

Do you want to produce 15 or 50 window units per shift? The performance and processing range of the CENTATEQ S-800|900 series can be tailored to meet your needs. Do you want to integrate your processing center into

an overall system and interlink it with the moulder, cross cut saw or flowcoater? Or expand the shift performance? Our team at HOMAG Systems will work with you to create the best possible overall concept to meet your requirements.

CENTATEQ S-800

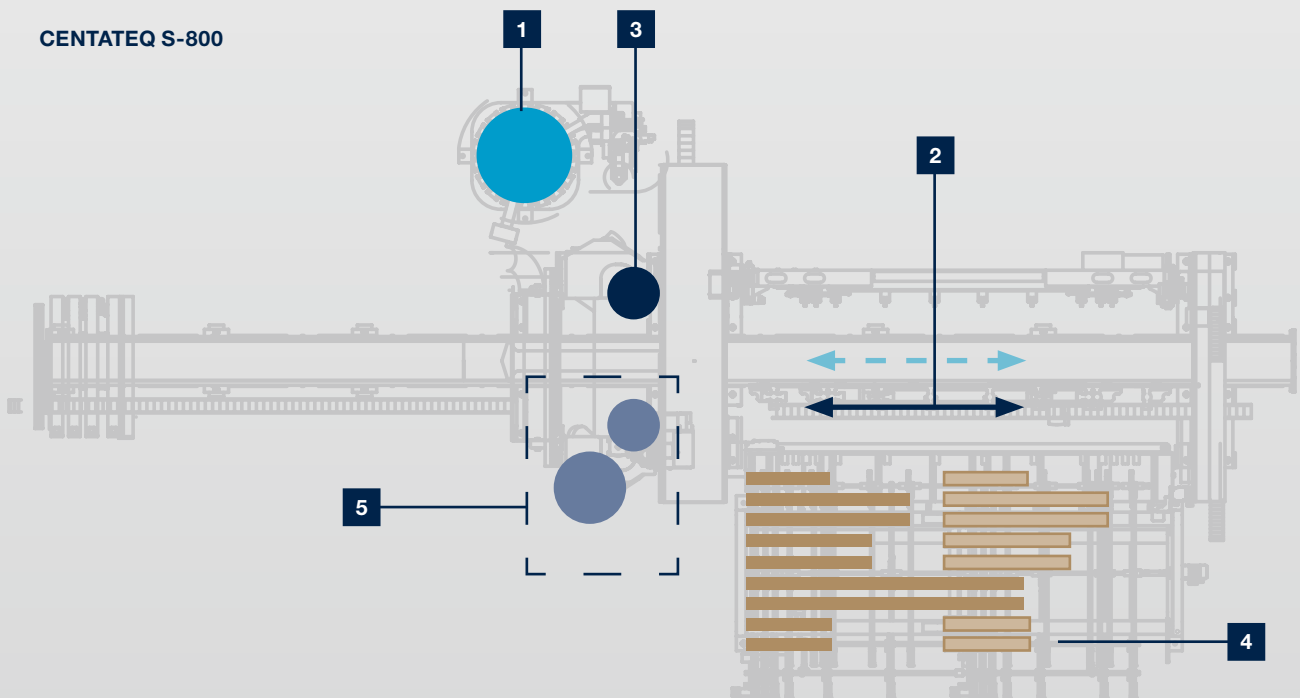

1 Tool changer: ToolTower tool changer with storage space for 36 or 72 items

3 Main spindle: Liquid-cooled main spindle for profiling and additional processing steps

5 Option: Auxiliary spindle: Additional trimming spindle with unit interface and a tool changer traveling with the spindle – ideal for sawing, drilling and routing. Tools can be changed during processing with the main spindle

2 One or two processing tables: A second processing table allows loading, reclamping and removal to be carried out independently of the processing at the other table

4 Option double assignment: As the tables can be dually assigned, tool change times can be reduced and the buffering capacity can be expanded



CENTATEQ S-900

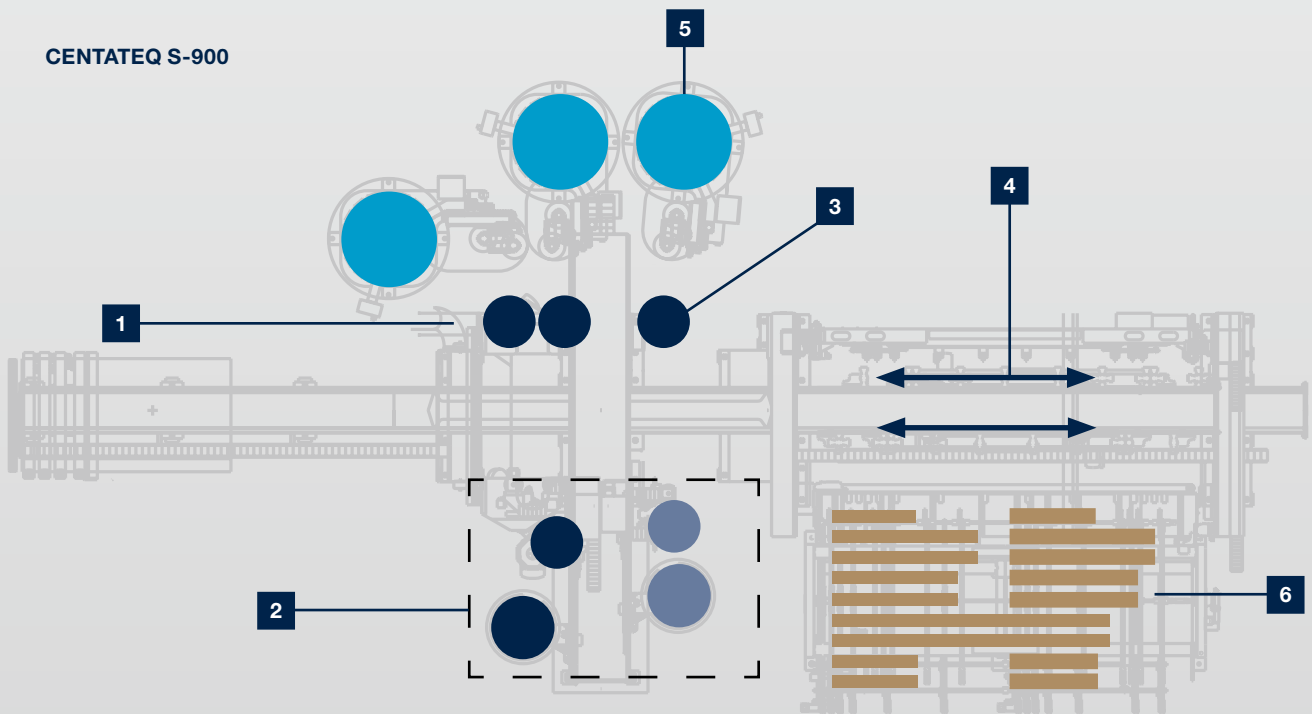

- | | | |
|---|--|--|
| <p>1 Profile splitting unit: Two trimming spindles in short distance and a ToolTower assigned to each spindle</p> | <p>3 Main spindle: Liquid-cooled main spindle for profiling and additional processing steps</p> | <p>5 Tool changer: ToolTower tool changer with storage space for 36 or 72 items</p> |
| <p>2 Auxiliary spindle: Additional trimming spindle with unit interface and a tool changer traveling with the spindle – ideal for sawing, drilling and routing. Tools can be changed during processing with the main spindle</p> | <p>4 Two processing tables: Processing, feeding, reclamping and removal on both tables</p> | <p>6 Double assignment: As the tables can be dually assigned, tool change times can be reduced and the buffering capacity can be expanded</p> |

Overall concept: Solutions tailored to your production

The autonomy of the machine can be improved by an extended depth of the infeed and outfeed transports. Feeding and removing becomes a minor matter. On focus are machine operation, quality control and secondary activities.

Or do you wish to integrate the processing center in an overall system and interlink it with hogging machine, cutting or surface treatment machines? Our team from HOMAG Systems designs you an individual overall concept.

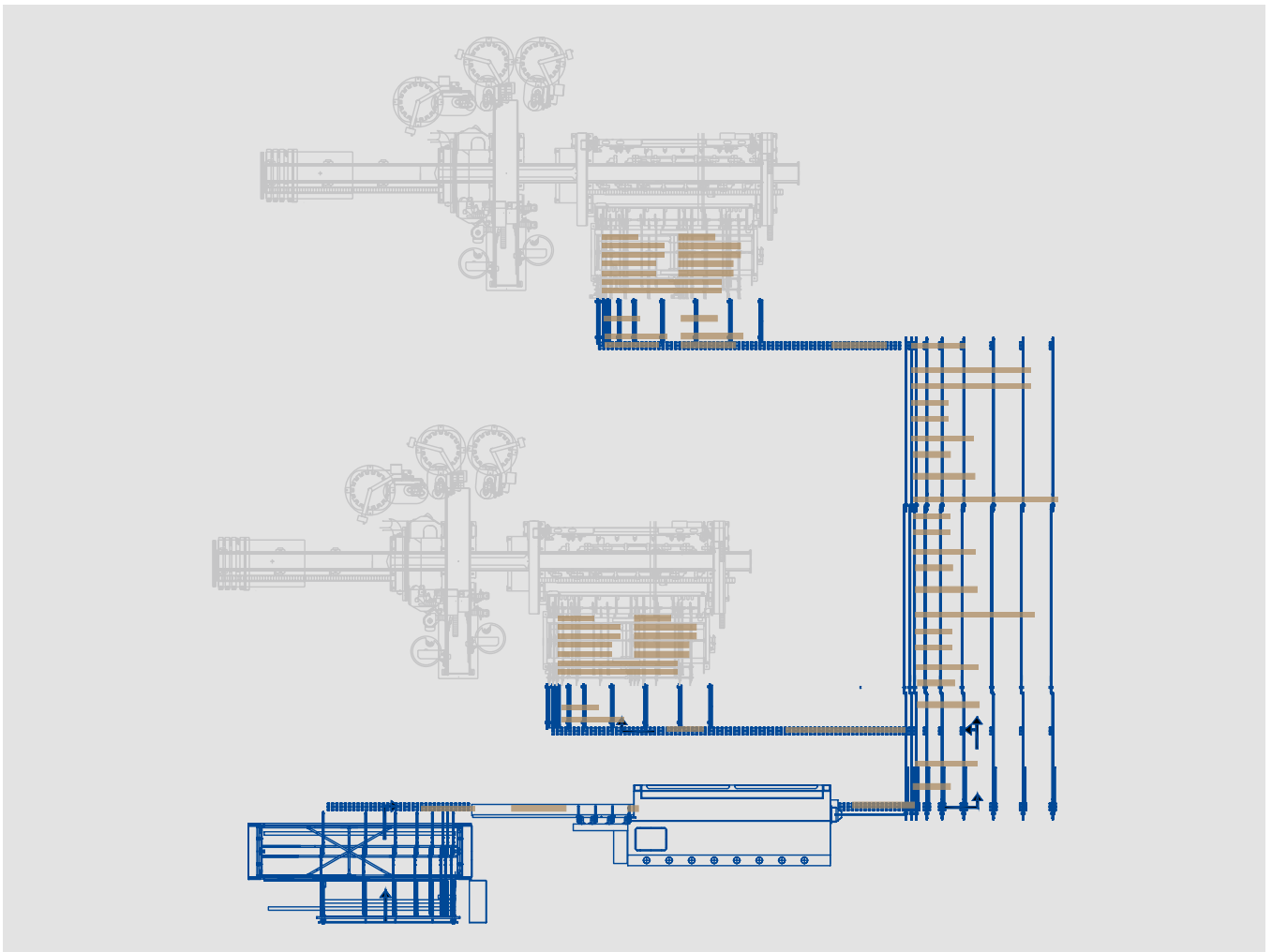

Individual interlinking to an overall concept: Higher performance? Integrated overall concept? We design an overall solution tailored to your requirements!

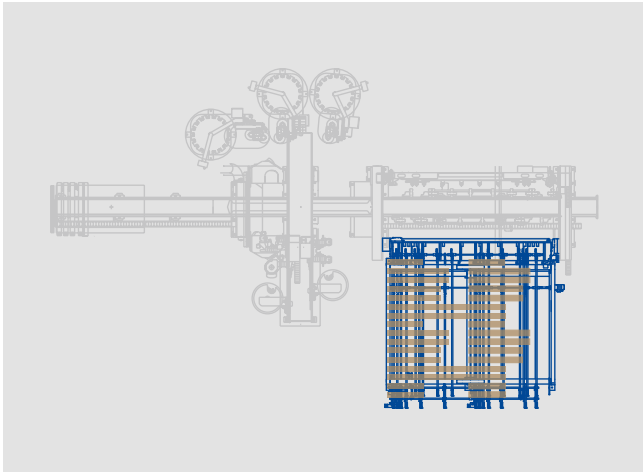

Extended infeed/outfeed belt: Extended autonomy due to higher buffer capacity in the infeed and outfeed - up to several hours.

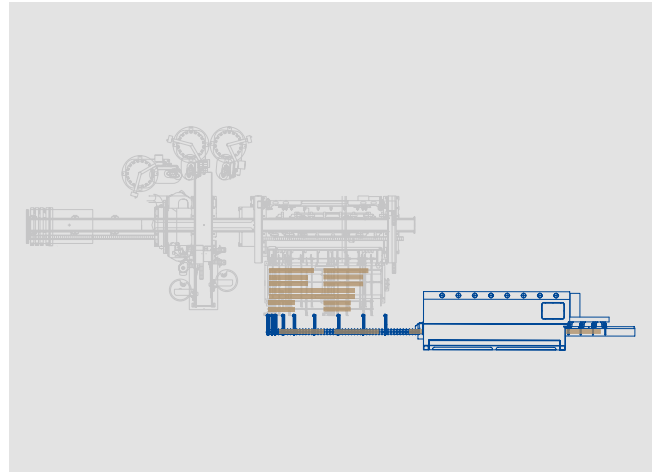

Angular transfer and connection to the hogging machine: Angular transfers and belt transports enable the interlinking with the hogging machine or snipping line.



Trolley with automatic workpiece feeding: For unmanned manufacturing and even longer processing cycles without operator.



Outfeed belt and connection to the flow-coating system: Transport belt in longitudinal direction instead of the outfeed belt with direct outfeed transport into the flow-coating system.

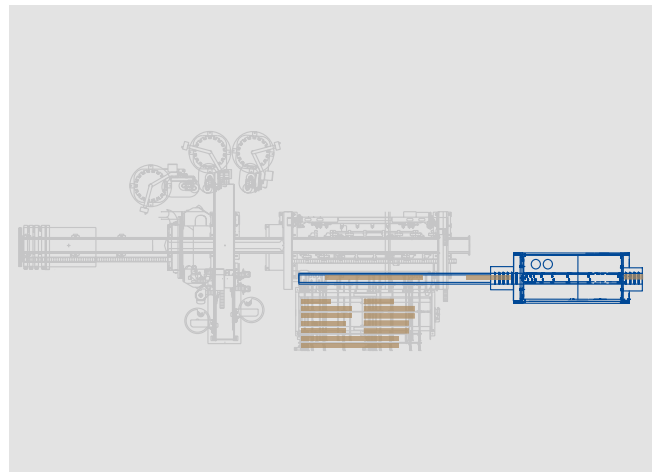
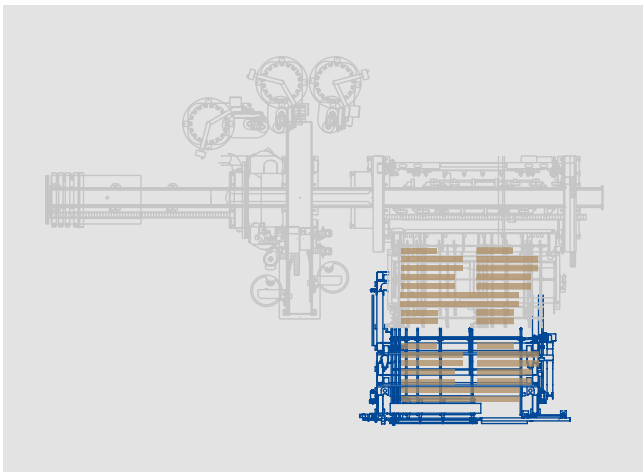

Easy. Efficient. Effective. HOMAG software solutions.

Our processing centres are one thing – the software needed for their convenient, simple operation day in, day out is another. This is why HOMAG software guarantees extreme flexibility and operating reliability. A matter of course at HOMAG: interfaces to external programming and design systems, help programs for interleaving and modules to help

you monitor your machine and track its performance. powerTouch is the operating philosophy of the HOMAG. It combines design and function to create a completely new control generation. The new system is characterized by the full HD multitouch monitor, ergonomic touch operation, simple navigation and the standardized user interface.



woodFlex: Production line control unit for the effective execution of production lists with graphical part visualization and tracking on the machine display. Thus, it is clear which part is at which point in the machine. woodFlex enables integration into production lines with upstream and downstream machines (e.g. 4-sided plane, snipping saw etc.)

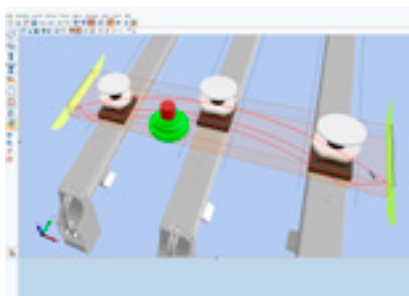

woodWOP programming system: Programming system for single parts, ideally suited for the parametric programming of special parts, e.g. special window shapes, conservatory parts, door leaves. Convenient use of macros (drilling patterns, lock casings, pocket routings etc.)

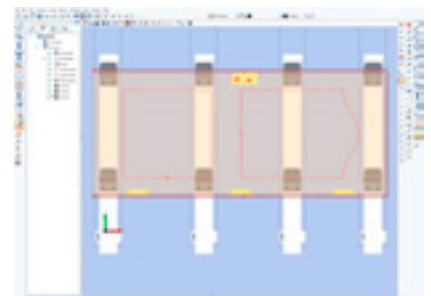

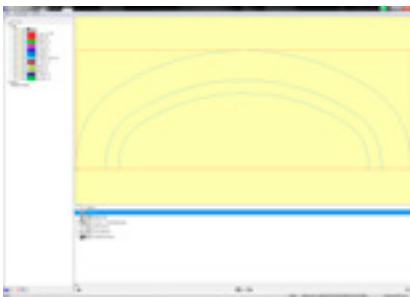

woodWOP DXF Import – interface for CAD data import:

- Automatic generation of woodWOP programs on the basis of CAD drawings
- Assignment of processing operations using layer names
- Using DXF Import professional, all woodWOP parameters can be defined using adjustable conversion rules and transferred to woodWOP



woodScout - help in your own language:

- Optional high-performance diagnostic system
- Graphic display of the fault location at the machine
- Clearly understandable plain text error messages in different languages
- Learning capability through the assignment of root causes and remedial actions (expert knowledge)

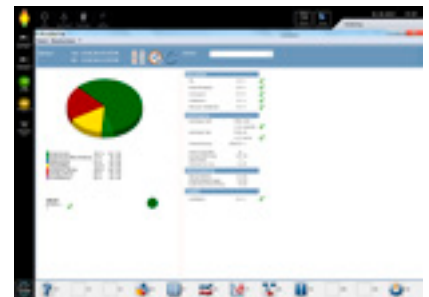

Machine data acquisition MDA – for a productive environment:

- Registration of piece numbers and ACTUAL operating times at the machine
- Integrated maintenance instructions for the optimum time and quality-based planning and execution of maintenance work
- Optional professional version allows detailed breakdown and logging of the recorded data

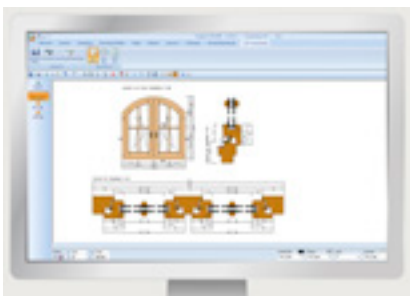

Interface to trade-specific software:

For the seamless integration of the machine into the IT environment. From automatic creation of all processing programs to dynamic machine assignment with automatic identification of the position of the clamping elements and many more features for high-performance window production.



Graphic tool database:

- Dimensioned graphics for simple set-up and management of tools and units
- 3D view of tools



Tool service life determination:

- Module for determining and logging tool service life
- Machine availability and workpiece quality are enhanced by the timely exchange of tools
- Cost reduction through optimized planning of tool deployment

HC LIFE CYCLE SERVICES

Optimal service and individual consultations are included in the purchase of our machines. We support you with service innovations and products which are especially tailored to your requirements. With short response times and fast

customer solutions we guarantee consistently high availability and economic production – over the entire life cycle of your machine.



REMOTE SERVICE

- Hotline support via remote diagnosis by our trained experts regarding control, mechanics and process technology. Thus, more than 92% less on-site service required and consequently a faster solution for you!
- The ServiceBoard App helps to solve tasks in a fast, simple and concrete way. This is achieved by mobile live video diagnosis, automatic sending of service requests or the online spare parts catalog eParts.



SPARE PARTS SERVICE

- High spare parts availability and fast delivery.
- Ensuring quality by predefined spare parts and wear parts kits, comprising original spare parts.
- Identify and inquire for spare parts online under www.eParts.de 24/7, or buy even faster and more comfortably in the new HOMAG eShop (shop.homag.com).



MODERNIZATION

- Keep your machinery up to date and increase your productivity as well as your product quality, This is how you can meet tomorrow's requirements today!
- We support you with upgrades, modernization as well as individual consultancy and developments.



DIGITAL SERVICES

- serviceRemote – the new remote service solution of the future! Fast restart of production because the remote service employee has extensive access to relevant physical data.
- serviceAssist – provides help for self-help. The preventive solutions proposed in the new App are the combination of our experiences and existing machine data.

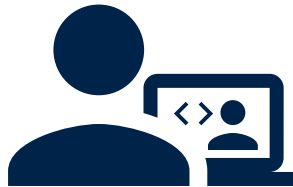

SOFTWARE

- Telephone support and consultancy through software support.
- Digitalization of your spare parts via 3D scanning saves time and money compared to new programming.
- Subsequent networking of your machinery with intelligent software solutions ranging from construction to production.



FIELD SERVICE

- Increased machine availability and product quality by certified service staff.
- Regular checks through maintenance/inspection guarantee the highest quality of your products.
- We offer you the highest availability of technicians in order to reduce downtimes in case of unpredictable troubles.

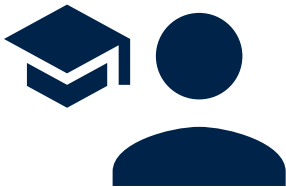

TRAINING

- Thanks to training perfectly suited to your requirements, your machine operators can optimally operate and maintain the HOMAG machines.
- The training also includes customer-specific training documents with exercises proven in practice.
- Online training and webinars. Learn without traveling, meet your trainer in the digital classroom.

For you more than...

1,350

service employees worldwide

92%

less on-site service thanks to successful remote diagnosis

5,000

customers in trainings / year

150,000

machines, all electronically documented in 28 different languages – in eParts

HOMAG Group AG

info@homag.com

www.homag.com



YOUR SOLUTION