

The high-powered

Four Shaft Shredders RMZ 500 - RMZ 1000 S



economical - sturdy - powerful

High powered four-shaft shredders: These machines shred waste residues and recyclable materials with ease. Ideal for reducing the volume of materials at an optimum cost-benefit ratio.

Other features include: Rugged design, very reliable, operator-friendly, low running costs, wide range of applications and particularly suitable for shredding lengthy objects.



Four Shaft Shredder RMZ 500 - RMZ 1000 S

The classical multi-shaft shredder in a modern design, combined with the know-how of Reinbold.

The rugged shredder is fitted with an electronic control system which protects the machine against overloading and switches off when empty. The large hopper and the blade shaft enable a high throughput rate at low power consumption.



Additional back-up shredders underneath the perforated screen prevent the occurrence of long chips. The radius of the perforation determines the size of the chip.

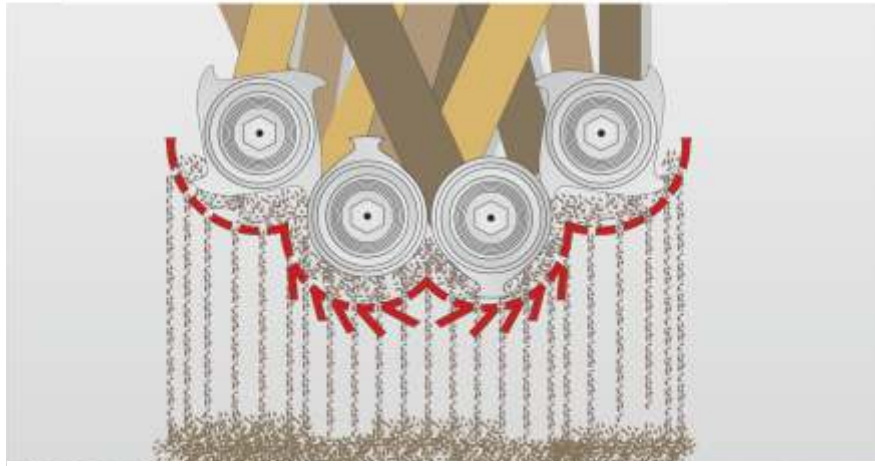

The cutting system comprises of 2 cutting shafts and 2 broaching shafts or optional of 4 cutting shafts.

The cutting system is driven by firm cogwheels which run in a closed oil bath.

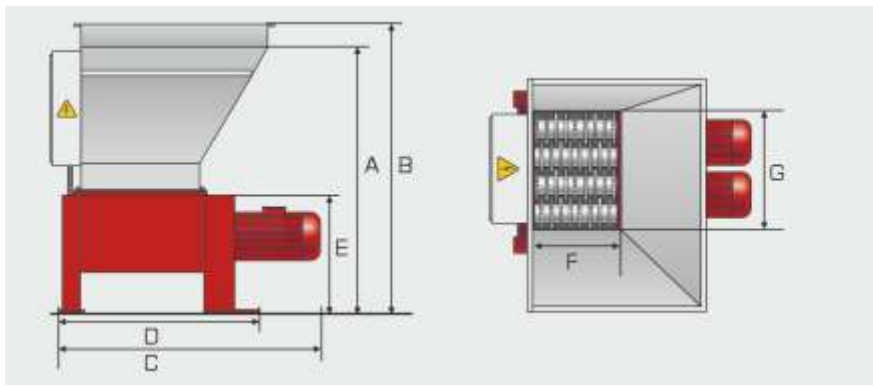

Type		RMZ 500	RMZ 700 S	RMZ 1000 S
Hopper opening				
Width	(mm)	1.000	1.400	1.400
Length	(mm)	1.250	1.300	1.500
Cutting tool opening				
Width (F)	(mm)	462	760	680
Length (G)	(mm)	562	700	1.000
Plate-Ø	(mm)	235	280	280
Motor output	(kW)	2 x 7,5 2 x 11	2 x 15 / 2 x 18,5 2 x 22	2 x 15 / 2 x 18,5 2 x 22 / 2 x 30
Throughput rate with a				
Perforation-Ø 20 mm	(kg)	300-500	600-1.200	800-1.500
Perforation-Ø 25-40 mm	(kg)	500-800	800-1.500	1.000-2.000
Weight	(approx. kg)	1.300	2.500	3.000
Dimension A	(mm)	1.660	1.660	1.690
Dimension B	(mm)	1.970	1.980	1.980
Dimension C	(mm)	1.400	1.780	2.250
Dimension D	(mm)	1.040	1.250	1.470
Dimension E	(mm)	830	830	830

* depending on material, conditions, screen size and input rate

Reinbold Entsorgungstechnik GmbH

Robert-Mayer-Strasse 5
74360 Ilsfeld (Germany)
Phone: +49 (0) 7062 / 97885-0
Fax: +49 (0) 7062 / 97885-50
info@reinbold.de
www.reinbold.de

Your dealer: