

Bandsägen

Bandsaws
Scies à ruban · Seghe a nastro



B 40 B 60 B 80



BS 631 BS 801

SB	390	580	780	610	780	SB
SH	270	370	450	385	500	SH
kW	1,5	2,2	4	3	3	kW
HT	860	875	970	940	970	HT
W	20°	20°	20°	30°	30°	W
H	1790	2000	2450	2110	2460	H
LT	500	830	1100	925	1230	LT
D2	120	120	120	100	100	D2
D3	-	-	120	100	120	D3

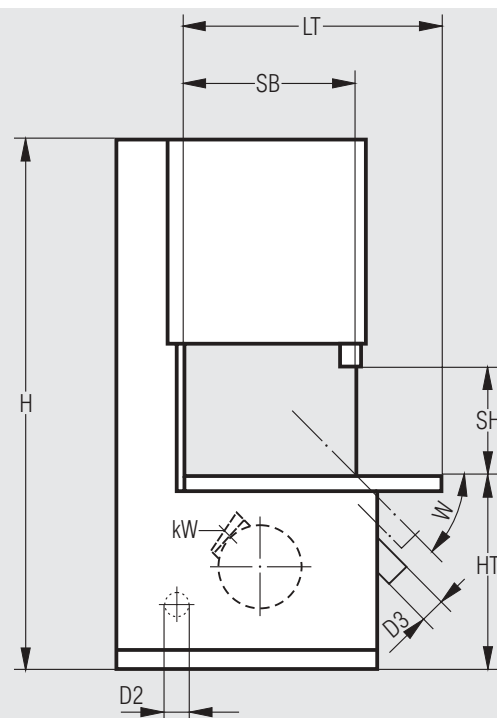

Hobelmaschinen

Planers
Raboteuses · Pialle



AS 510



DM 630

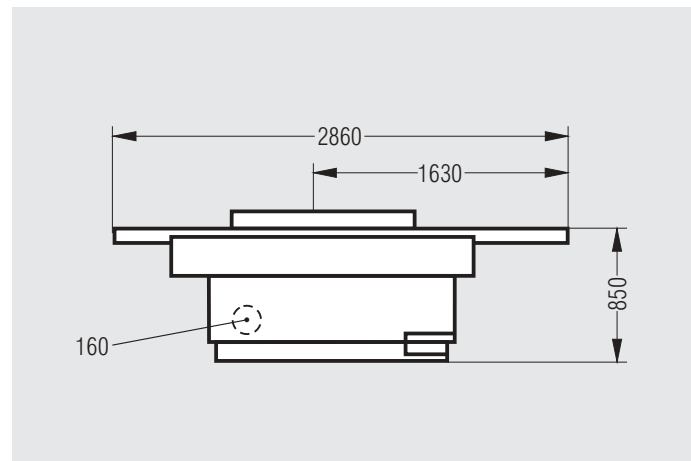

HB = 510 kW = 5,5

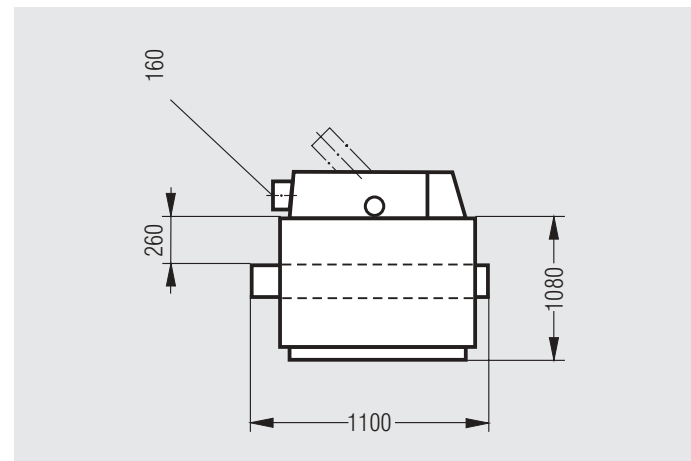

HB = 630 kW = 7,5 + 11

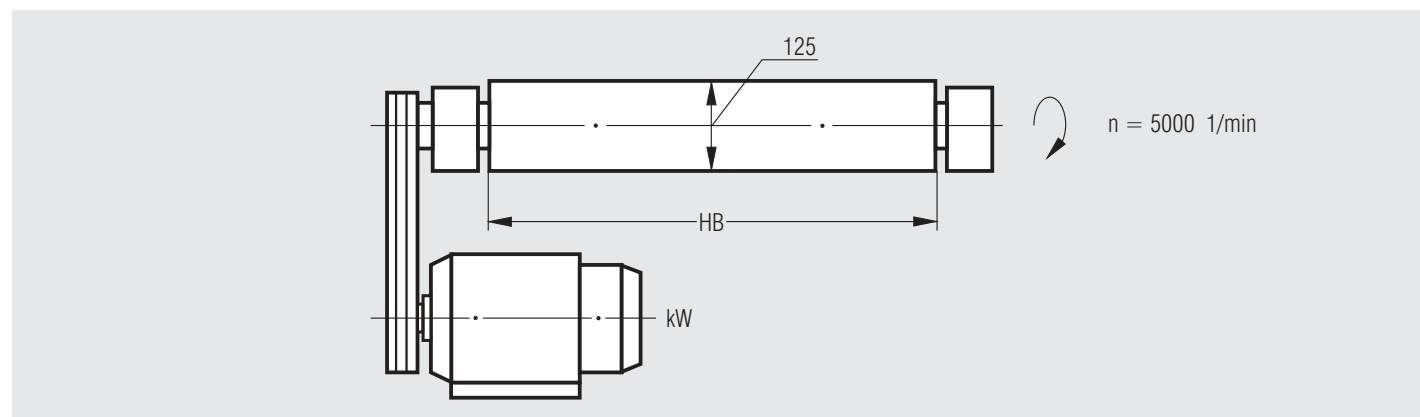

Bäuerle GmbH & Co.
Maschinenbau-Werkzeuge KG
Lindenhofstraße 1
D-73529 Schwäbisch Gmünd

Telefon 07171 / 186 580, 186 581
Telefax 07171 / 186 582
eMail: info@baeuerle-maschinen.de



Holzbearbeitungsmaschinen

Woodworking machines
Machines à Bois
Macchine per la lavorazione del legno



seit 1855

www.hoechsmann.com

Fräsmaschinen

Spindle Shapers
Toupies · Frese



SFM 101-3



SFM 102-3



SFM 200-3



SFM 201-3



PM 250

PM 510

5,5
7,5
5/6
7,5/9,5

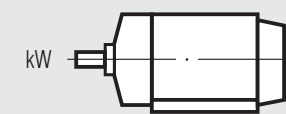

5/6
7,5/9,5

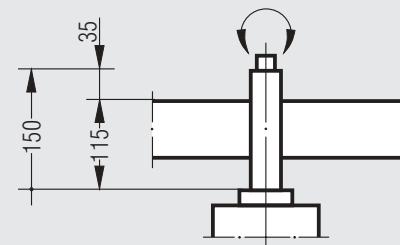

n 1/min.
(1500)
3000
4500
6000
9000
12000

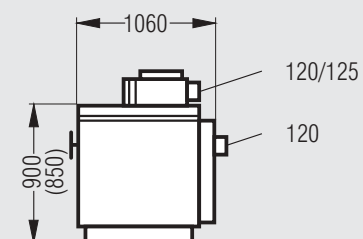
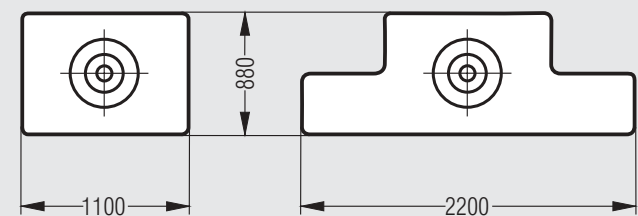
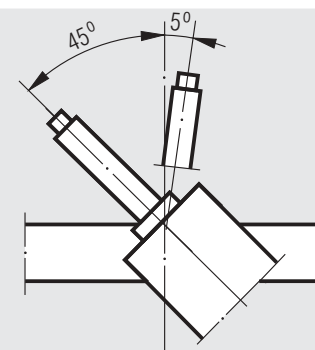

kW	11	15
B	260	510
H	200	200
n 1/min	6000 standard 4800 standard 4000 option	6000 standard 4800 standard 4000 option

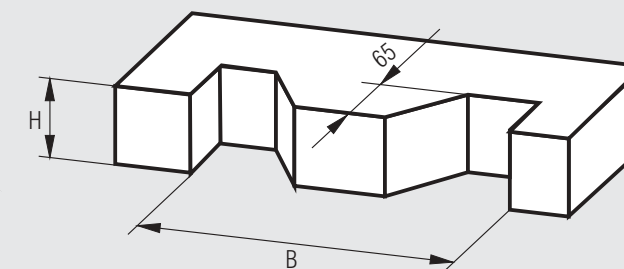
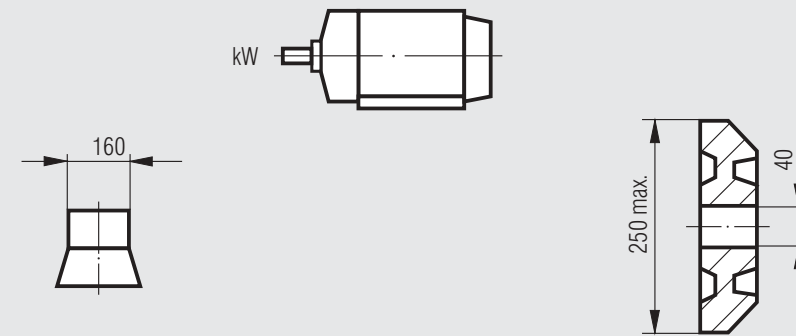

Kreissägen

Circular-Saws
Scies Circulaires · Seghe circolari



PKS

