

# ELIX

DRILLING MACHINE-HOLE  
BORING MACHINE

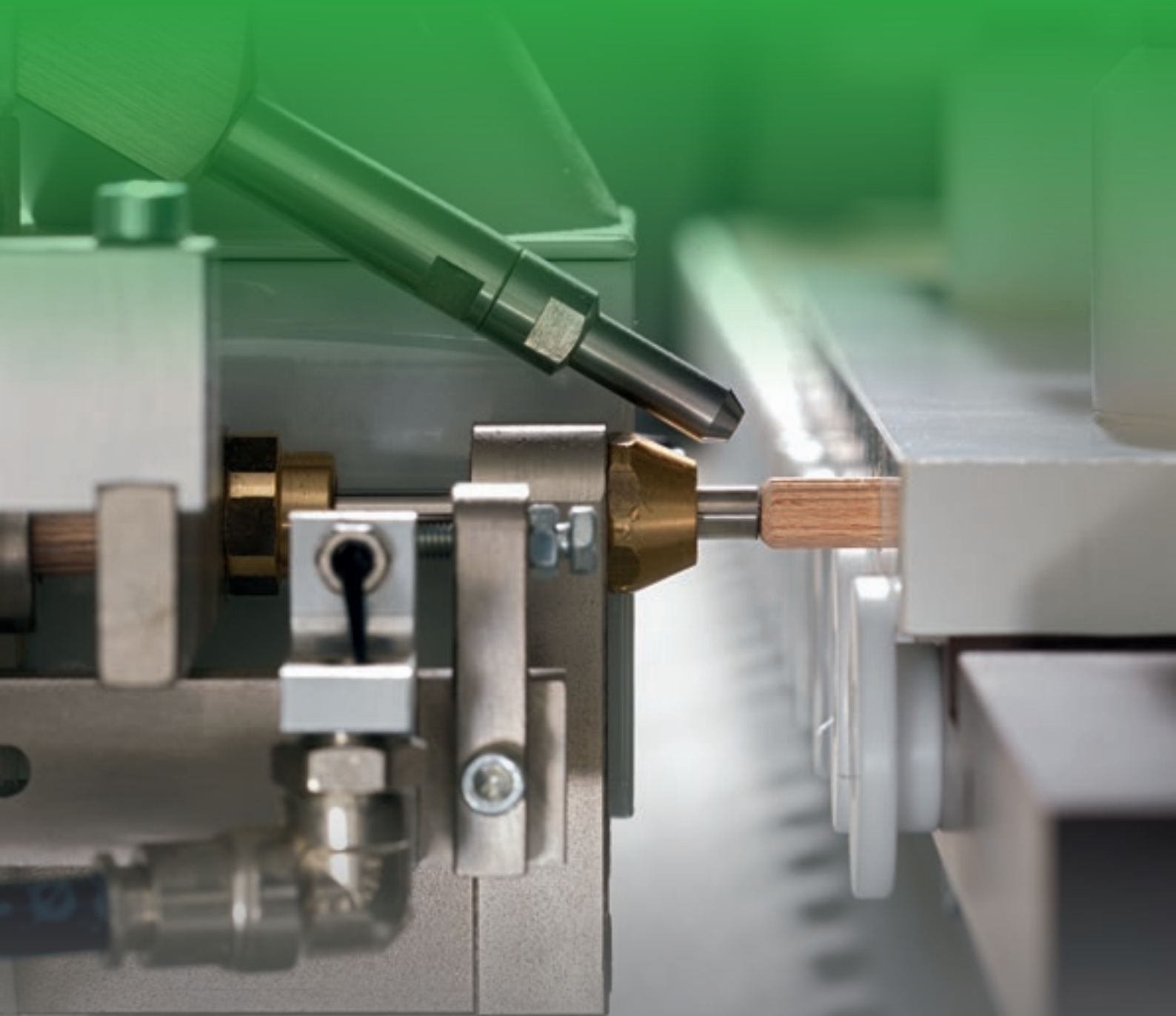

 **BIESSE**

# MAXIMUM FLEXIBILITY FOR HORIZONTAL BORING



## THE MARKET DEMANDS

a change in manufacturing processes, enabling companies to **accept the largest possible number of orders**. This is coupled with the need to maintain high quality standards while offering product customisation with quick and defined delivery times, as well as responding to the needs of the most highly automated enterprises.

## BIESSE RESPONDS

with **technological solutions** that enhance and support technical skill and knowledge of the processes and materials. **Elix** is the hole boring machine for point-point dowels that is perfect for flexibly carrying out boring operations or boring and insertion operations for the manufacture of kitchens, furniture, drawers, and small pieces.



## ELIX

- ✔ MAXIMUM QUALITY OF THE FINISHED PRODUCT
- ✔ PERSONALISATION OF THE MACHINE ACCORDING TO MANUFACTURING NEEDS
- ✔ USER FRIENDLY



# MAXIMUM PRODUCTIVITY AND QUALITY OF THE FINISHED PRODUCT

Fast, flexible, and efficient, the ELIX series is the most reliable hole boring machine on the market. ELIX's technology ensures that glue and plugs are properly inserted.



ELIX is equipped with a laser system for reading the length and width of a piece, guaranteeing the utmost precision.

The optical fibre verifies the presence of dowels in order to avoid any errors.

The pressers hold the piece still during machining operations without scratching it and without negatively impacting the machine's productivity.

Numerous configuration possibilities to satisfy various market needs:

- ✔ ELIX K1
- ✔ ELIX K2
- ✔ ELIX K3
- ✔ ELIX K4
- ✔ ELIX K5



# EXTREMELY EASY TO USE



PROGRAMMING THAT IS EASY,  
IMMEDIATE, AND AT EVERYONE'S LEVEL  
THANKS TO THE CONTROL PANEL.



PC with Windows operating system and  
an intuitive interface that is at everyone's  
level.

A high pressure glue pump system with  
a cleaning circuit that guarantees an im-  
peccable finished product.



# TECHNICAL SPECIFICATIONS

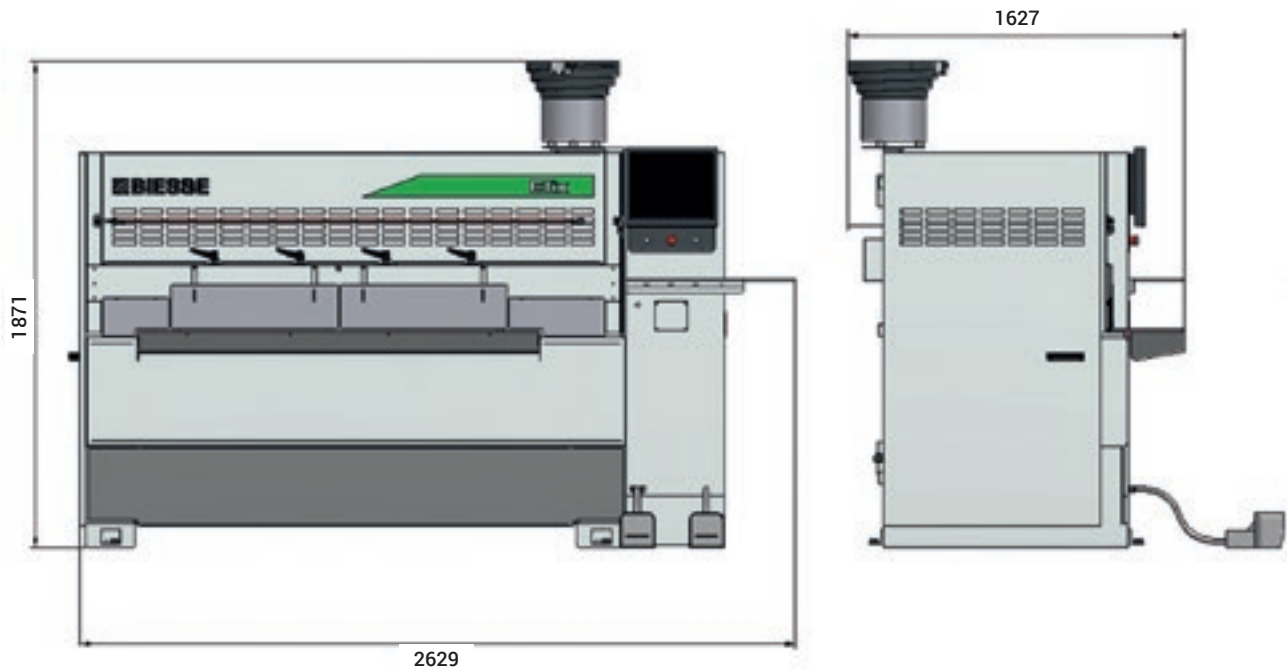

Workable panels length Elix K1-K2	mm/inch	max 900/35,4
Workable panels length Elix K3-K4-K5	mm/inch	max 1300/51,2
Thickness of workable panels	mm/inch	10 - 40 (60 opz.)/ 0,39-1,57 (2,36 opt.)
Rotation speed Horizontal drilling unit	rpm	6000
Max horizontal depth of the holes with dowel insertion	mm/inch	30/1,18
N. 1 dowels inserter - Standard dowel	mm/inch	dia. 8 x 30/0,31 x 1,18
Vertical drilling unit (opt.)	n.	1
Vertical drilling unit rotation speed	rpm	4500
Max. Vertical hole depth	mm/inch	40/1,57
Working field 'Y' vertical drilling unit	mm/inch	0 - 40/0 - 1,57

The technical specifications and drawings are non-binding. Some photos may show machines equipped with optional features. Biesse Spa reserves the right to make modifications without prior notice.

A weighted sound pressure level (LpA) during machining for operator workstation on vane-pump machine Lpa=79dB(A) Lwa=96dB(A) A-weighted sound-pressure level (LpA) for operator workstation and sound power level (LwA) during machining on cam-pump machine Lwa=83dB(A) Lwa=100dB(A) K measurement uncertainty dB(A) 4.

The measurement was carried out in compliance with UNI EN 848-3:2007, UNI EN ISO 3746: 2009 (sound power) and UNI EN ISO 11202: 2009 (sound pressure levels at workstation) during panel machining. The noise levels shown are emission levels and do not necessarily correspond to safe operation levels. Despite the fact that there is a relationship between emission and exposure levels, this may not be used in a reliable manner to establish whether further measures need to be taken. The factors determining the exposure level for the workforce include length of exposure, work environment characteristics, other sources of dust and noise, etc. i.e. the number of other adjoining machines and processes. At any rate, the above information will enable the operator to better evaluate dangers and risks.

# BIESSE BORING RANGE

## VERTICAL BORING AND INSERTION



Skipper V31



Brema Eko 2.1



Brema Eko 2.2



Brema Eko 902

## VERTICAL BORING AND INSERTION



Brema Vektor 15



Brema Vektor 25



Brema Idrak

## BORING



Active Drill



Insider FT2



Insider FTT

## BORING



Insider M



Insider Door FB



Techno Line

## BORING AND INSERTION



Elix



Matrix



Insider Door KB

# SERV ICE & PARTS

Direct, seamless co-ordination of service requests between Service and Parts. Support for Key Customers by dedicated Biesse personnel, either in-house and/or at the customer's site.

## BIESSE SERVICE

- ✔ Machine and system installation and commissioning.
- ✔ Training centre dedicated to Biesse Field engineers, subsidiary and dealer personnel; client training directly at client's site.
- ✔ Overhaul, upgrade, repair and maintenance.
- ✔ Remote troubleshooting and diagnostics.
- ✔ Software upgrade.

**500**

Biesse Field engineers in Italy and worldwide.

**50**

Biesse engineers manning a Teleservice Centre.

**550**

certified Dealer engineers.

**120**

training courses in a variety of languages every year.

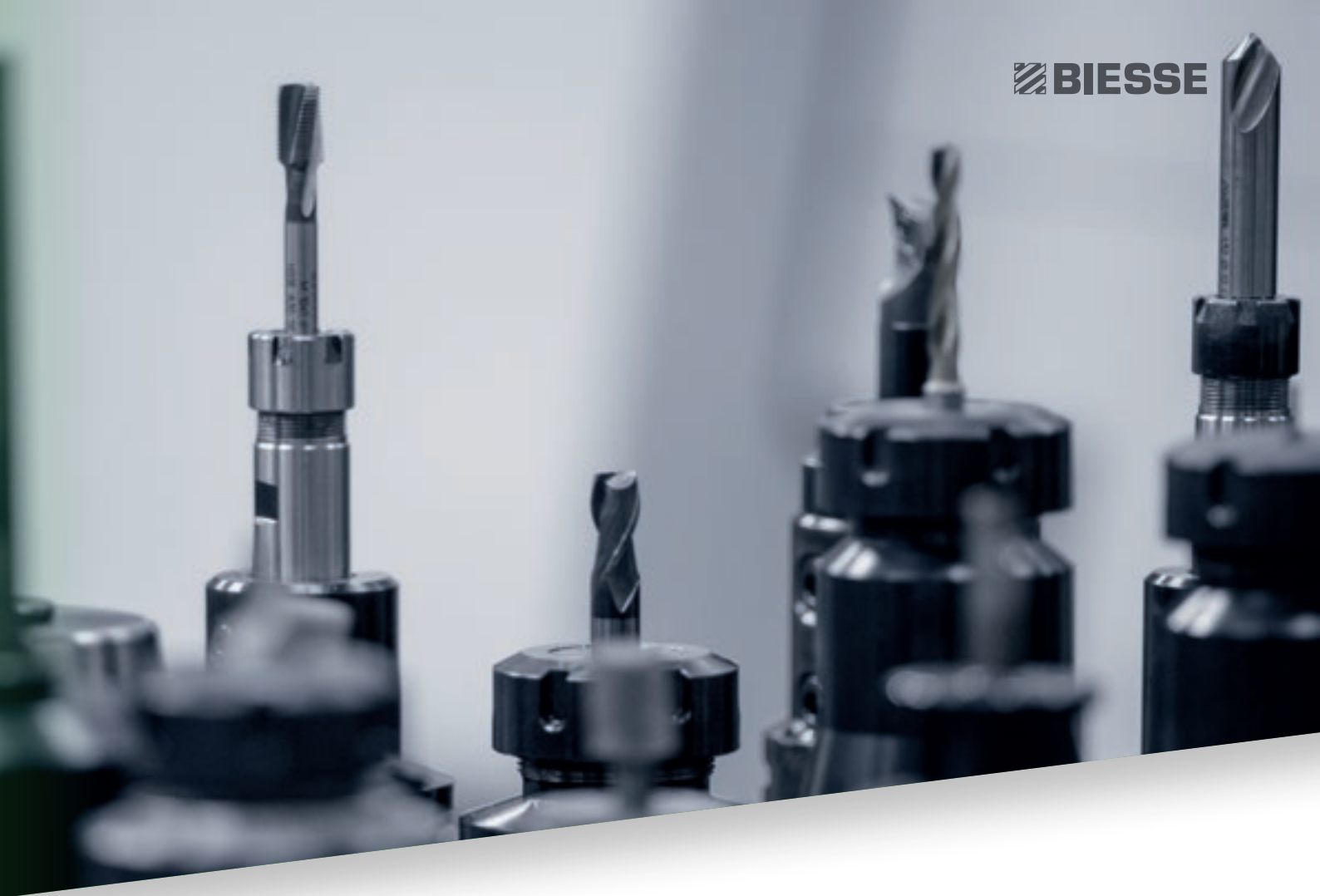

A close-up photograph of several metal drill bits and tool components, arranged in a row. The bits are of different sizes and designs, some with standard double-flute and others with more complex, multi-fluted designs. They are set against a blurred background, highlighting their metallic texture and sharp edges.

The Biesse Group promotes, nurtures and develops close and constructive relationships with customers in order to better understand their needs and improve its products and after-sales service through two dedicated areas: Biesse Service and Biesse Parts. With its global network and highly specialized team, it offers technical service and machine/component spares anywhere in the world on-site and 24/7 on-line.

## BIESSE PARTS

- ✔ Original Biesse spares and spare kits customized for different machine models.
- ✔ Spare part identification support.
- ✔ Offices of DHL, UPS and GLS logistics partners located within the Biesse spare part warehouse, with multiple daily pick-ups.
- ✔ Order fulfillment time optimized thanks to a global distribution network with de-localized, automated warehouses.

**92%**  
of downtime machine orders fulfilled  
within 24 hours.

**96%**  
of orders delivered in full on time.

**100**  
spare part staff in Italy and worldwide.

**500**  
orders processed every day.

# MADE WITH BIESSE

## BIESSE GROUP TECHNOLOGIES JOIN FORCES WITH LAGO'S INNOVATION AND TOTAL QUALITY MANAGEMENT PROCESSES.

In the crowded world of domestic design, Lago takes its place as an emerging brand, thanks to a collection of stimulating products and a corporate philosophy that embraces the interaction between business and art, coupled with on-going research into sustainable development.

"We created a number of projects, or rather, concepts - states Daniele Lago - that have shaped Lago as we see it today: we saw design as a cultural vision that applies not only to individual prod-

ucts, but rather to the entire business chain".

"Flexibility is the key word here at Lago" says Carlo Bertacco, Manufacturing Manager. "We started to introduce the concept of processing only outstanding orders, which enabled us to reduce our footprint and empty the site from the very beginning".

"The machinery that we purchased - states Bertacco - is great, it entailed a limited investment versus the capabilities it offers and is linked to a specific

manufacturing approach. What I am talking about is a given manufacturing volume with Lago-standard quality levels and the possibility of customising as late as possible, at the customer's request: in short, the very basic principles of lean manufacturing".

*Source: IDM Industria del Mobile  
Lago, our customer since 1999, is one of most prestigious Italian furniture brands in the world.*



# LIVE THE EXPERIENCE

BIESSEGROUP.COM



Interconnected technologies and advanced services that maximise efficiency and productivity, generating new skills to serve better our customer.

**LIVE THE BIESSE GROUP EXPERIENCE AT OUR CAMPUSES ACROSS THE WORLD.**



**BIESSEGROUP**

