



WEINIG

WACO

GRECON DIMTER

Laminating press for solid timber panels

ProfiPress

High-quality
timber panels
produced with
intelligent
laminating
technology



GreCon Dimter
Timber Optimizing

A company of the Weinig Group

ProfiPress – the heart of your panel production

With the new ProfiPress, small and medium size companies can now produce edge glued panels in a particularly economical and market-oriented way. With accurate and firmly closed joints. With smooth surfaces and without vertical mismatches. With highly flexible productivity due to short curing and changeover times. And with a completely new, efficient and highly accurate gluing technique. The ProfiPress adapts to your specific production requirements without any problems. It is based on a modular system and can be extended as required: from a simple basic machine to a highly automated press line with cross-cut saws and automatic

feeding systems such as board cutting centres and stacking systems. ProfiPress: a product from the Weinig Group – the Group of companies with the most comprehensive expertise in solid wood machining worldwide.

How the ProfiPress functions:

- Once the glue has been applied the workpieces are assembled at the layup station.
- The feed plate automatically transports the package into the pressing section.
- The counter pressure at the end of the press bed remains active and ensures pre-pressure during the infeed.
- Pressure units from above keep the pressed boards flat during the loading sequence.
- A solid pusher plate raises from below and produces horizontal pressure on the joints.
- The heating period starts – the pressure is continuously applied and controlled.
- Simultaneously, a new layer is being assembled at the layup station.
- At the end of the curing cycle, the pressure plate moves back into the lower position and the next layer is fed in.

Completely new, unique pressing technique – patent pending

The pressure at the front is produced by a pressure plate. At the rear the panels are held by spring-loaded friction elements. This ensures an even pressure on the joints – independent of the thickness of the material and any possible build-up of glue. During endless laminating, the joints are absolutely parallel with the saw cut. Random lamella

widths can also be glued to produce a perfect panels without any problems. Only GreCon Dimter, the laminating specialist, can offer you the precision and perfection you need!

High frequency generator

RF application for optimal use: reducing pressing time with corresponding increase in throughput.

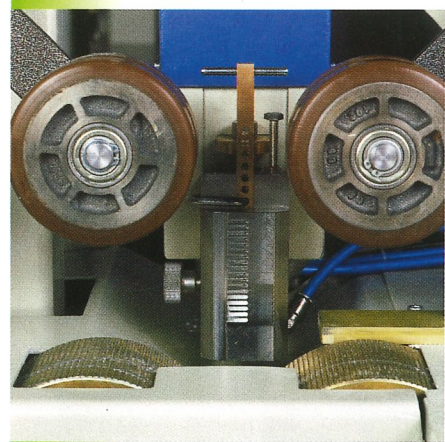
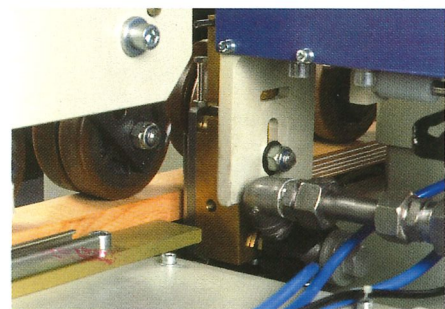

Precise glue application.



Self-contained heating using hot water. Thermo oil or RF are available as options.



ProfiPress: panels of any length, any thickness and any timber species.

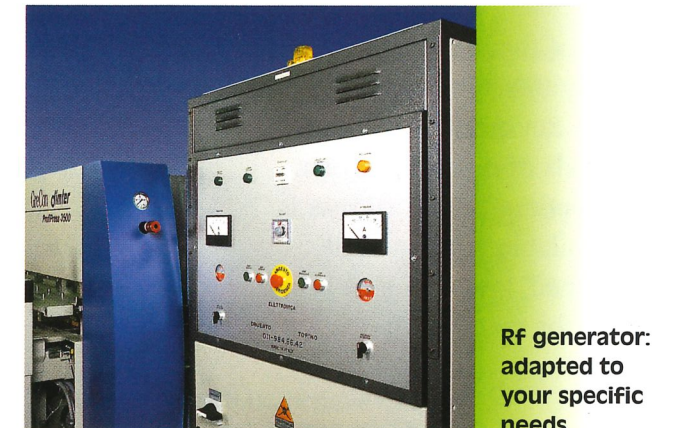

Rf generator: adapted to your specific needs.

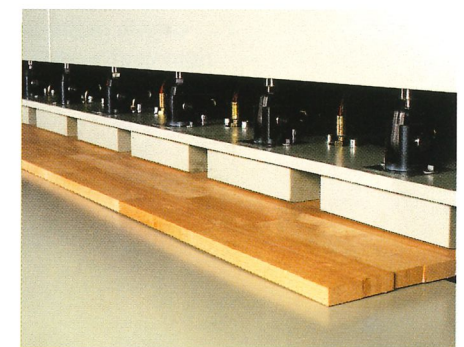

Individual, spring-loaded pressure elements at the rear ensure even pressure on all joints (independent of the number of layers, build-up of glue or thickness tolerances).



Heavy positioning fence, tiltable. Quick manual or electrical adjustment.

State of the art technology – GreCon Dimter technology

Unrivalled: the glue application

The application head (extruder) applies the glue in an extremely precise manner, reducing excess glue and time-consuming cleaning. Glue application ensures short pressing times and optimal quality of the joints. The glue saved by this system during production can quickly add up to thousands of dollars per year. As an option, the ProfiPress is also available with an easily maintained, low cost glue roller system for manual application.

Lay-up station

The lay-up collecting station is equipped with hold down bars. The panels are coated before being transported into the press so that the glue can penetrate into the material or drain-off, before it reaches the pressing section. Optimum utilization of the press due to multiple layer pressing.

Hydraulic top pressure unit at the front

Bowed or twisted workpieces are pressed down flat as they enter the press. Reducing vertical mismatches and producing timber savings during subsequent sanding or planing.

Automatic unloading

The feed plate can move the entire length of the machine, automatically unloading the pressing section.

Heating system

Choice of hot water or thermo oil can be used, either with integrated heating or with the possibility to connect to an existing heating system.

Precision glue application – original GreCon Dimter. Fine dosing of glue reduces costs and shortens heating and cleaning time. A must for high-capacity production!

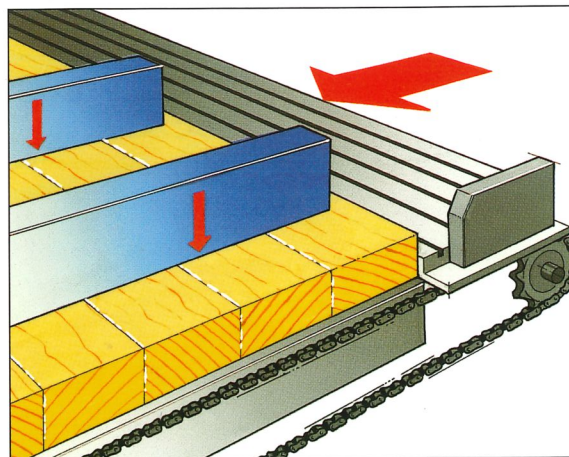
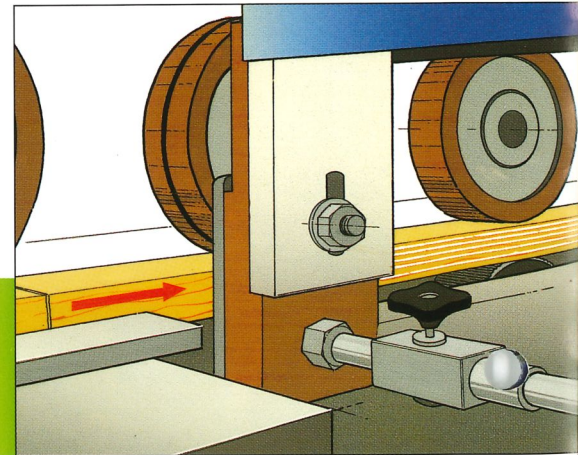

New technology from GreCon Dimter! Lay-up station with hold down bars producing pressure on the glue joints. The glue penetrates the joints, pressing times are reduced.

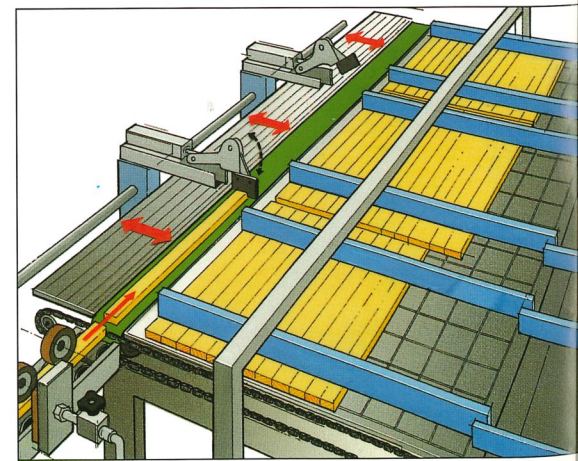

Short lengths: several layers next to each other ensure optimum utilization of the pressing section. Manual or motorized positioning of fences.

Safe endless gluing

The bottom table is stationary, the upper press section moves. This ensures troublefree endless

gluing. The top table prevents thin pieces from moving over one another during the loading cycle.

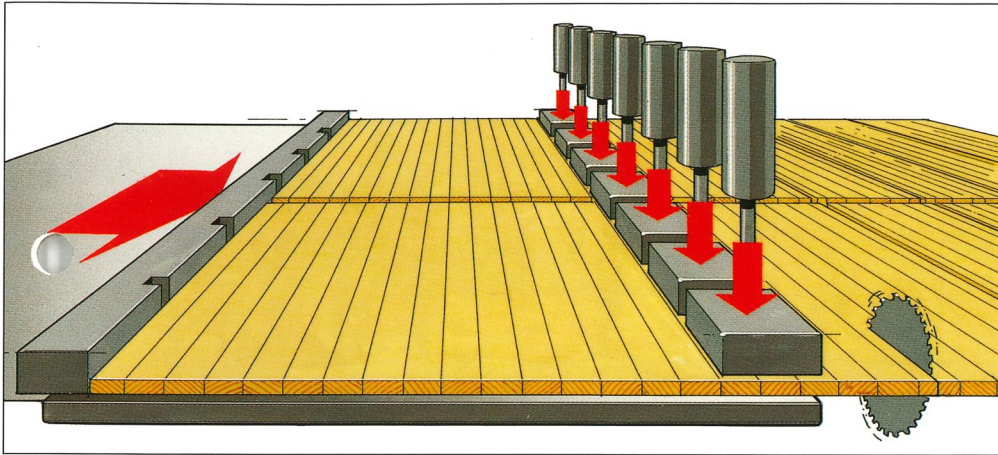

New technology from GreCon Dimter: Solid hydraulic pusher plate at the front and individual brake and holding elements ensure full pressure on all joints – and for endless gluing the saw cut is absolutely parallel with the line of the glue joint!

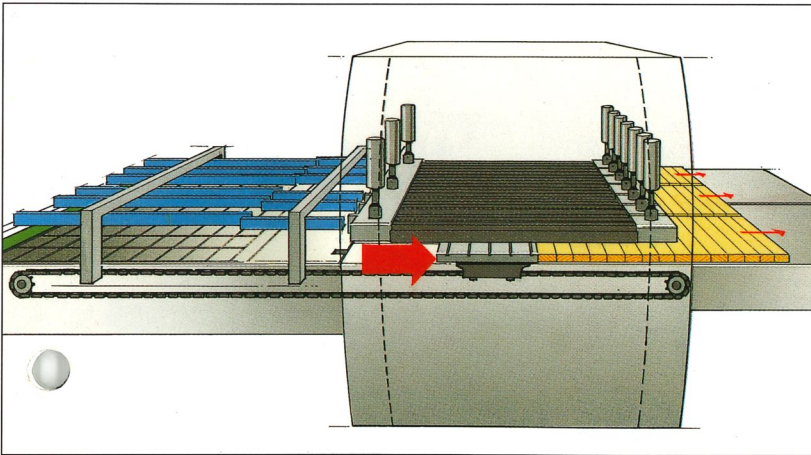

Feeding plate with chain drive up to the end of the pressing bed enables fast and automatic unloading and loading of the press when dimensions are changed. Guarantees high flexibility and productivity.

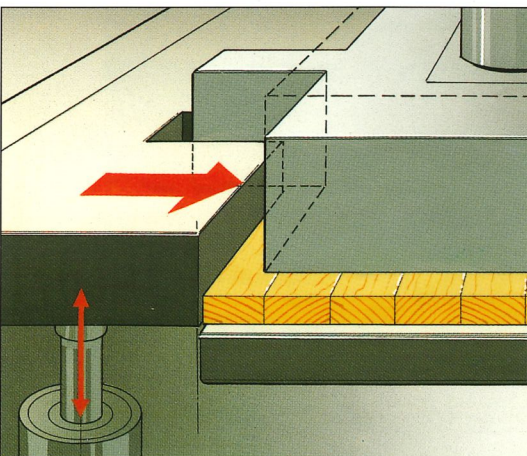

New technology from GreCon Dimter: The upper pressing section and the hydraulic pusher automatically adapt to any new timber thickness, made possible by fingers in the pressing table and slots in the pusher plate. More production time, no operator errors!

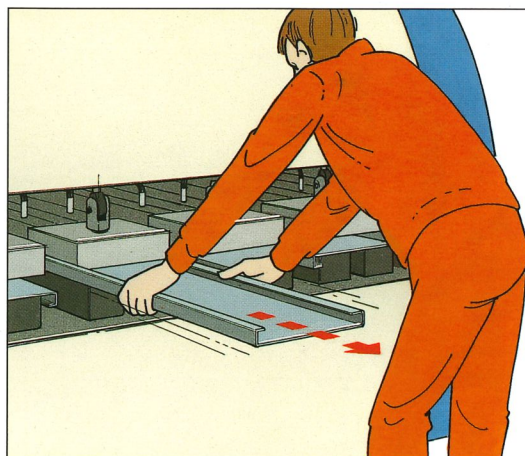

New technology from GreCon Dimter: Pressing bed of light, individual special steel profiles which are easily cleaned. Removal and replacement takes only a few minutes – therefore more real production time!

Growing with the requirements

Standard options

- glue application with roller or precision extruder
- glue applicator cleaning device
- feeding systems from infeed belt up to cross conveyors
- layer assembly from manual to automatic for one layer or multiple layers, independent of lengths and widths.
- heating systems with hot water, integrated or external
- heating tubes with insulation

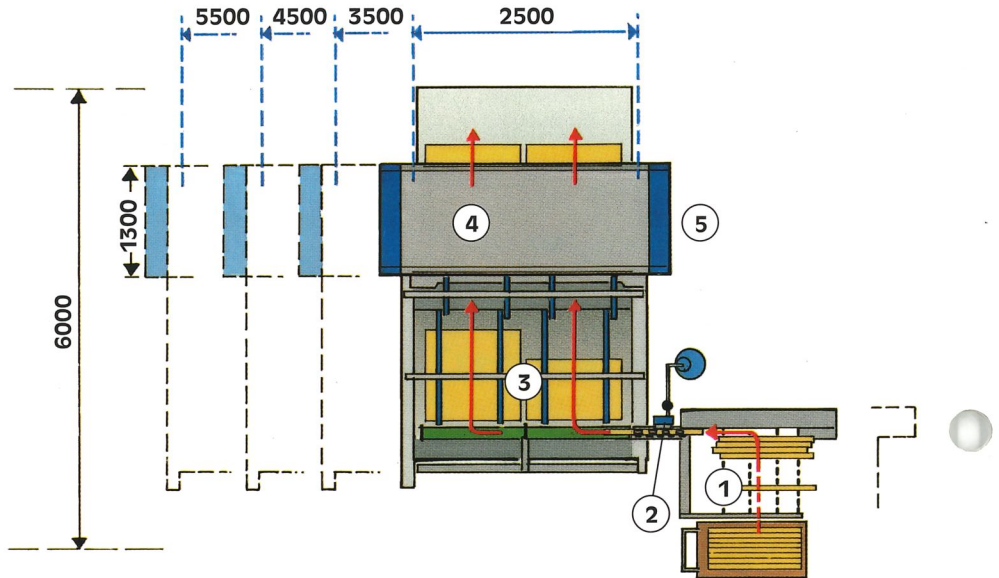

Comfort options

- Production package: rapid order input from the PC to the machine, detailed statistics
- Operator package: quick resetting to new dimensions, automatic adjustment of pressure
- Automatisation package: automatic infeed and outfeed systems, cut-to-size saws, automatic panel stacking systems
- Efficiency package: fast collection of short lengths, high frequency for fastest curing of glue joints
- Diagnosis package: display of operator errors and functional problems. On-line with GreCon Dimter Service.
- „All from one supplier“ package: Linked to a Weinig planing machine – responsibility from one source.

You can retrofit any comfort option at any time – we will adapt it to your specific needs.

1. Infeed station
2. Glue application
3. Lay-up station
4. Pressing and heating section
5. Optional: high frequency

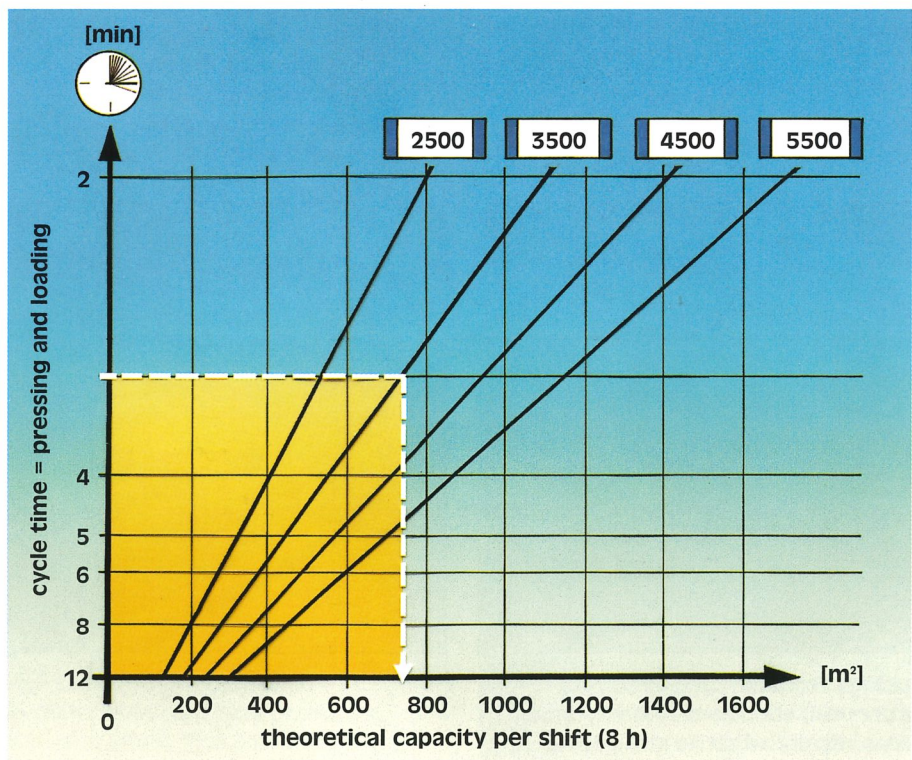

Panel gluing center

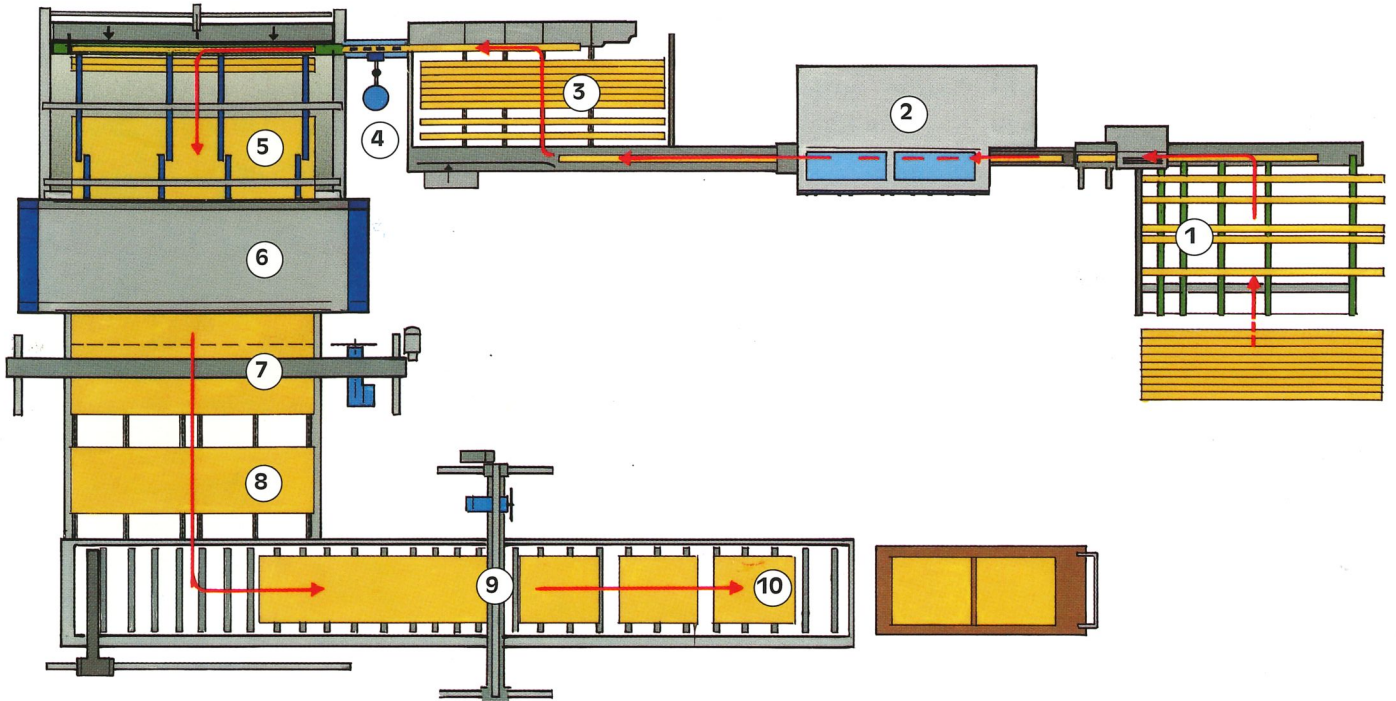

- | | |
|-------------------------------------|---|
| 1. Weinig Feeders | 6. Pressing and heating section |
| 2. Weinig Precision Planing Machine | 7. Cut-to-width saw |
| 3. Transfer and sorting station | 8. Transfer station |
| 4. Precision glue application | 9. Cut-to-length saw |
| 5. Lay-up station | 10. Transportation to stacking or sanding |

Technical data

Width of lamellas*	30 - 150 mm
Thickness of panels*	11 - 60 mm
Length of panels	300 - 5500 mm
Width of panels	variable
Timber species	hardwoods and softwoods
Glue	all types
Heating temperature	< 85° C / water < 140°C / thermo oil
High frequency carefully adapted to the application profile by specialists	15 - 120 kW

*other dimensions possible
Please contact us.

We reserve the right to make technical changes. Statements and pictures in this brochure may contain items which are not included in the standard scope of supply. Some protective covers have been removed for photographing.

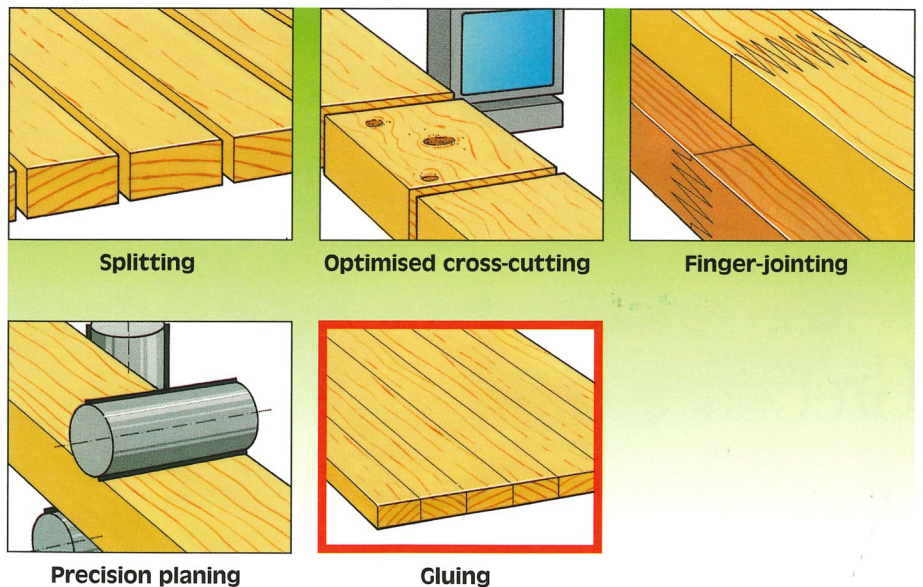

**Everything from a single source :
The Weinig Group**

GreCon Dimter is GreConDimter plus Weinig plus Waco

No where in the world will you find a bigger concentration of solid woodworking expertise than within the companies of the Weinig Group. Visit Weinig in

Tauberbischofsheim where you can see the world's bestselling moulders coming off the assembly line. Visit the demonstration and training center, like thousands

of timber experts every year to get an up-date on the most recent developments. Should you be near Alfeld or Illertissen, visit GreConDimter to find out the latest about optimizing cross-cut saws, finger jointing lines and edge and face gluing systems. And should you be in Sweden, visit Waco in Halmstad where you can see how the world's fastest and most powerful planing and moulding machines are manufactured. You are always welcome at the companies of the Weinig Group. Give us some advance notice so that we have all the time you need.



GreCon *dimter*

Timber Optimizing

Factory:

GreCon Dimter
Rudolf-Diesel-Strasse 14-16
D-89257 Illertissen
Telephone (0) 73 03 15-0
Telefax (0) 73 03 15-199
E-mail info@gd-sued.de
Internet www.grecon-dimter.de

Sales office:

Michael Weinig AG
Weinigstrasse 2/4
D-97941 Tauberbischofsheim
Telephone (0) 93 41 860
Telefax (0) 93 41 70 80
E-mail info@weinig.de
Internet www.weinig.com

