



## ***Giant Line***

***1350-1650-1900-2200***

***With this you can do everything!***



# **EMC**

***Real Finishing***



Heavy duty machine

# Giant Line

1350-1650-1900-2200



Configurazione 4 operatori  
Configuration 4 groups  
Configuration à 4 groupes



**The industrial sander**

# Flexibility of configuration, the choice is yours!

Heavy duty machine

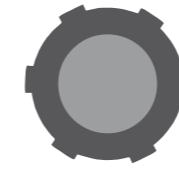
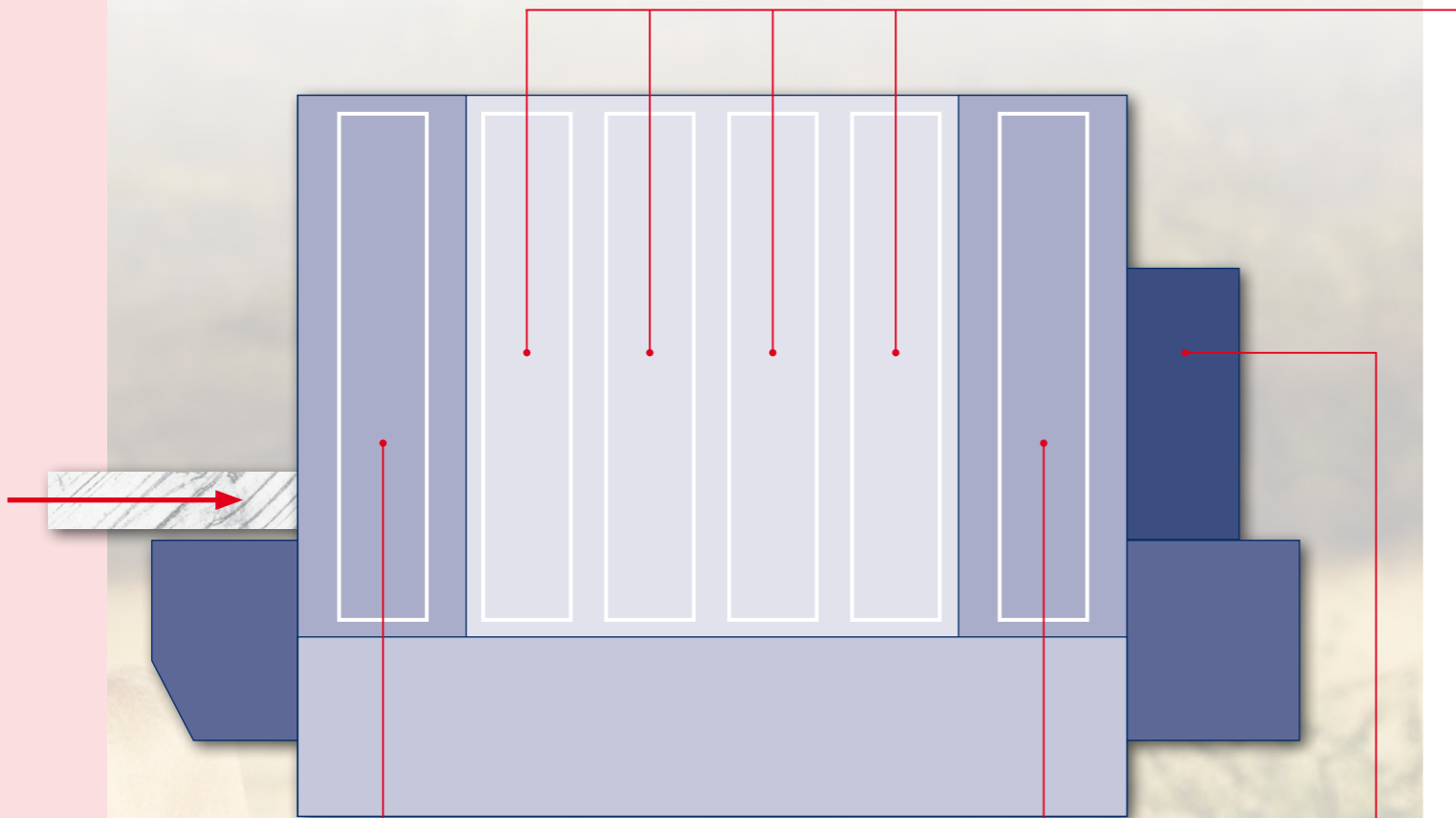

Gruppo operatore Pialla  
Planner head unit  
Groupe de ponçage à couteaux

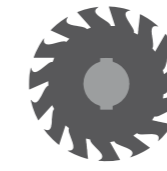

Gruppo operatore multilama  
Blade unit  
Unité de lame



Gruppo operatore Rullo  
Working unit roller  
Groupe de ponçage à Rouleau



Gruppo operatore Kombi  
Kombi Group  
Groupe de ponçage Kombi



Gruppo operatore Pattino  
Electronic segmented pad  
Groupe de ponçage patin

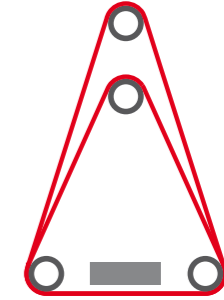

Gruppo operatore Superfinitore  
Superfinishing pad  
Groupe de ponçage de Superfinition

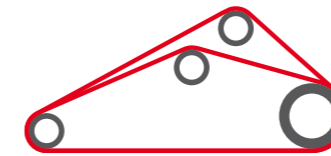

Gruppo operatore trasversale interno  
Internal electronic cross sanding pad  
Groupe de ponçage transversal à l'intérieur

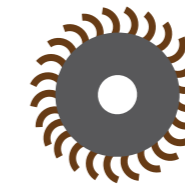

Gruppo spazzola  
Brushing unit  
Groupe de brossage à Brosse

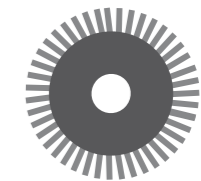

Spazzola rusticatrice  
Structuring brush unit  
Brosse rusticatrice



Gruppo spazzole tangenziali 1x  
Tangential brushes unit 1x  
Unité de Brosse Tangentielle 1x

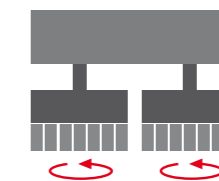

Gruppo spazzole tangenziali 2x  
Tangential brushes unit 2x  
Unité de Brosse Tangentielle 2x

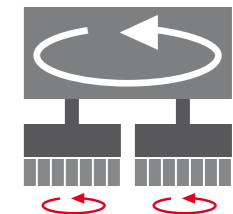

Sistema planetario  
Planetary system  
Système planétaire



Gruppo trasversale compatto  
Compact cross belt  
Bande trasversale compacte



Gruppo trasversale lungo  
Long cross belt  
Longue bande trasversale



Gruppo spazzola Ø200  
Brushing unit Ø200  
Groupe de brossage à Brosse Ø200



Gruppo spazzola Ø150  
Brushing unit Ø150  
Groupe de brossage à Brosse Ø150



Turbo-soffiatori  
Turbo rotating blowers  
Turbo soufflettes



Soffiatore compatto  
Compact blower  
Soufflette compacte

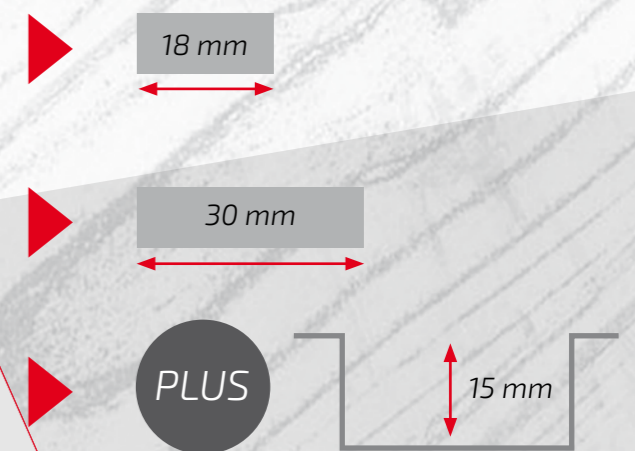
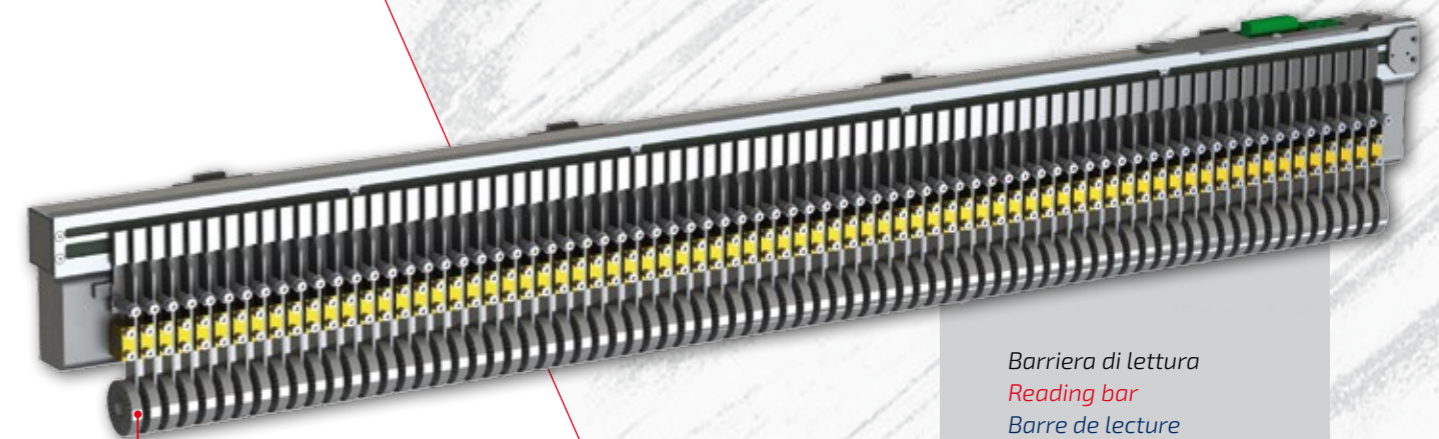
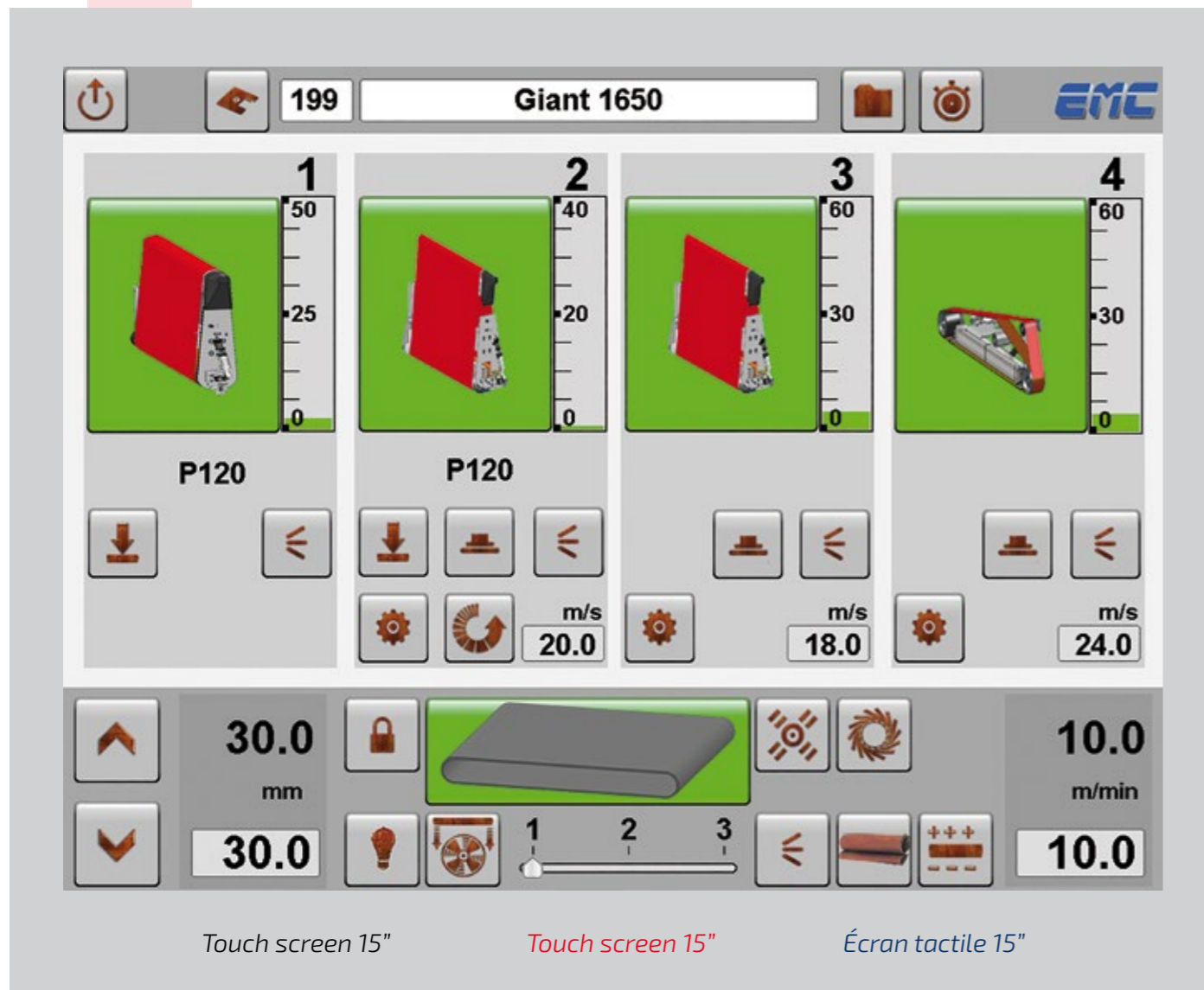

# INDUSTRY 4.0 READY

Gruppi tampone installabili  
*Pad group installable*  
 Patin Instalable

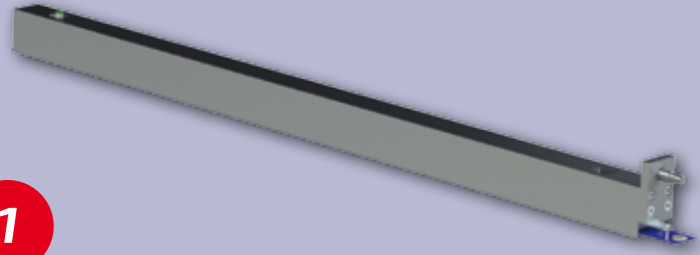
**1**  *Tampone pneumatico*  
*Pneumatic pad*  
 Patin pneumatique

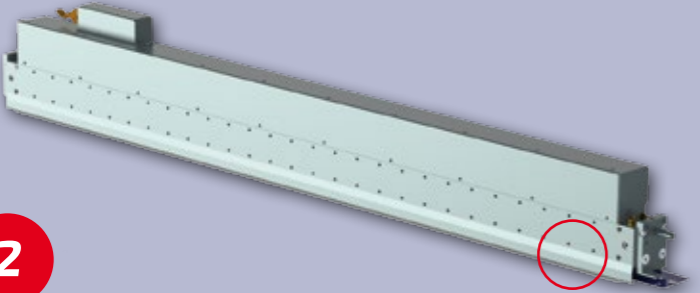
**2**  *Tampone settore 18mm*  
*Sector pad 18mm*  
 Patin secteur 18mm

**18 mm**

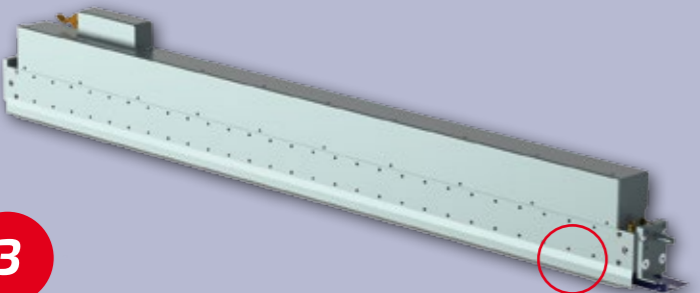
**3**  *Tampone settore 30mm*  
*Sector pad 30mm*  
 Patin secteur 30mm

**30 mm**

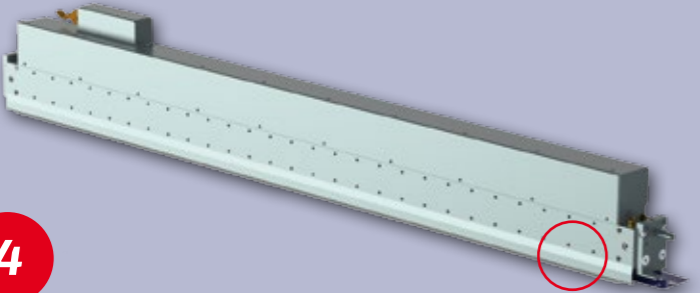
**4**  *Tampone PLUS (escursione 15mm)*  
*PLUS pad (excursion 15mm)*  
 Patin PLUS (excursion 15mm)

**PLUS** 15 mm

Gruppo trasversale compatto  
*Compact cross belt*  
 Bande transversale compacte

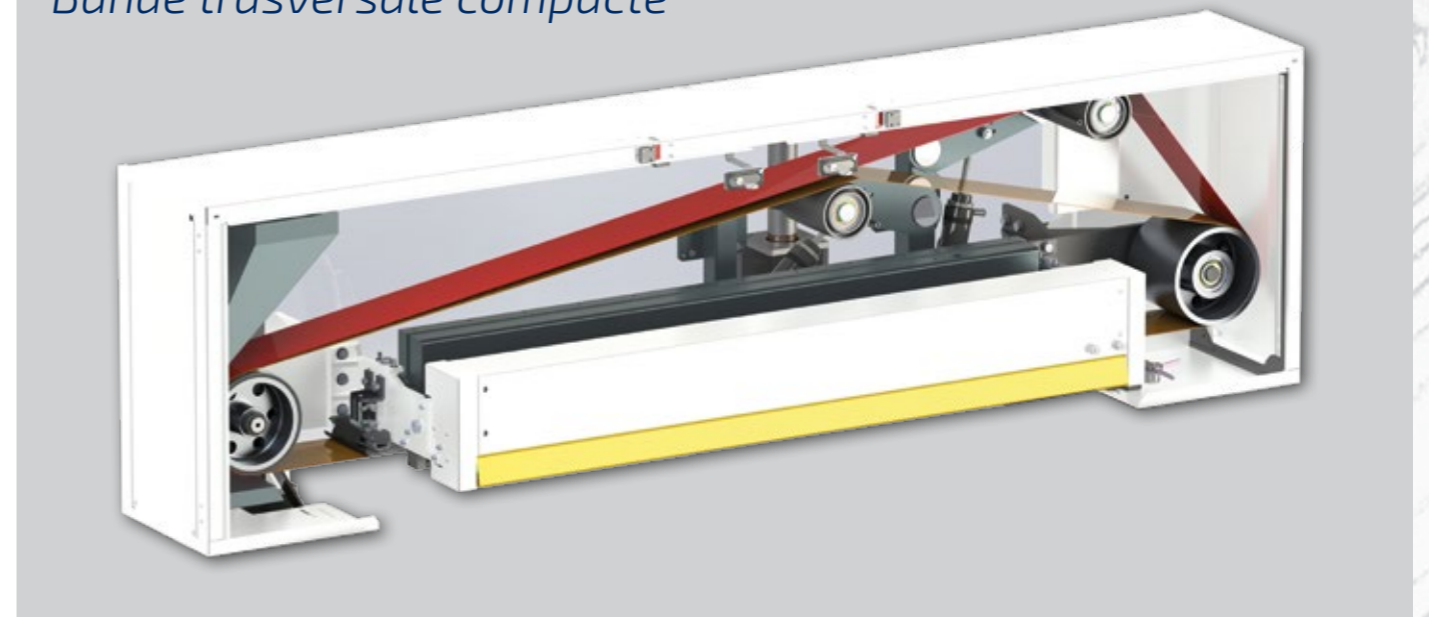

**2** **18 mm** *Tampone settore 18mm*  
*Sector pad 18mm*  
 Patin secteur 18mm

**3** **30 mm** *Tampone settore 30mm*  
*Sector pad 30mm*  
 Patin secteur 30mm

**4** **PLUS** 15 mm *Tampone PLUS (escursione 15mm)*  
*PLUS pad (excursion 15mm)*  
 Patin PLUS (excursion 15mm)

Gruppo trasversale lungo  
*Long cross belt*  
 Longue bande transversale



Regolazione micrometrica della posizione di lavoro del tampone  
*Micrometer adjustment for the pad position*  
 R glage microm trique de la position de travail du patin



Gruppo operatore multilama  
*Blade unit*  
 Unité de lame

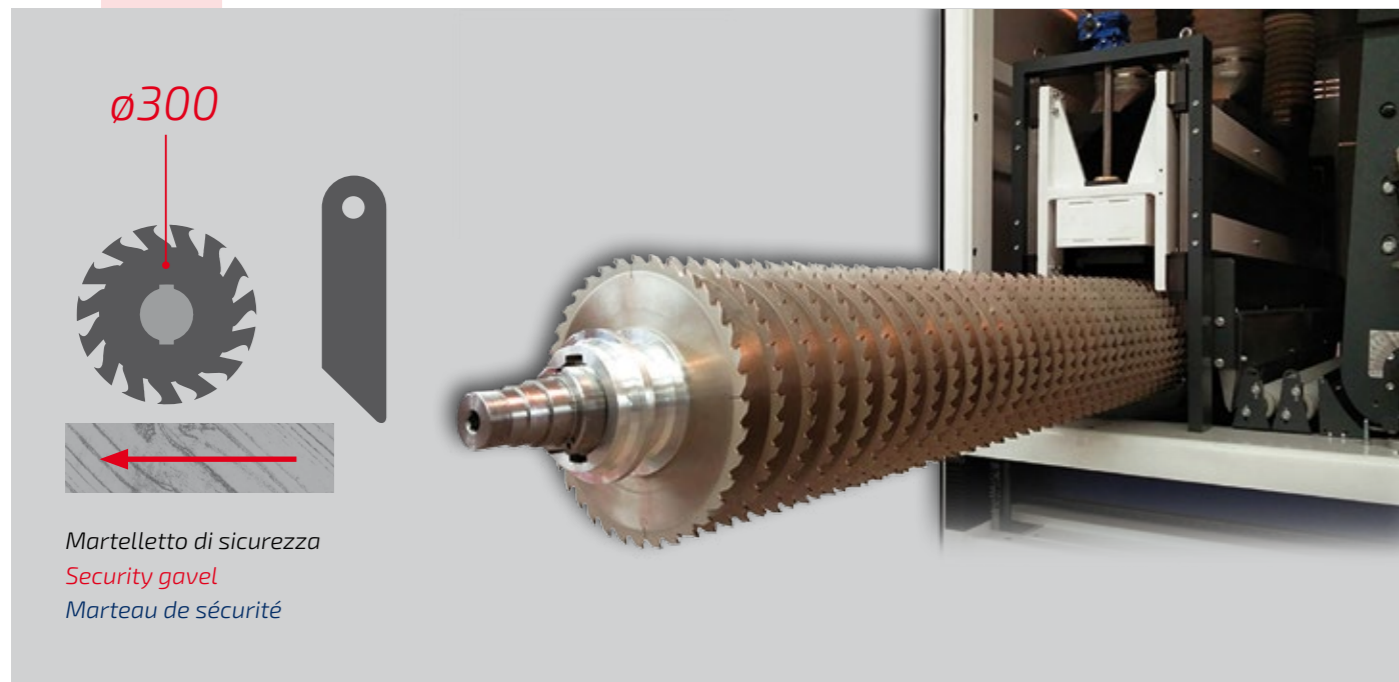

Gruppo operatore Pialla  
*Planner head unit*  
 Groupe de ponçage à couteaux

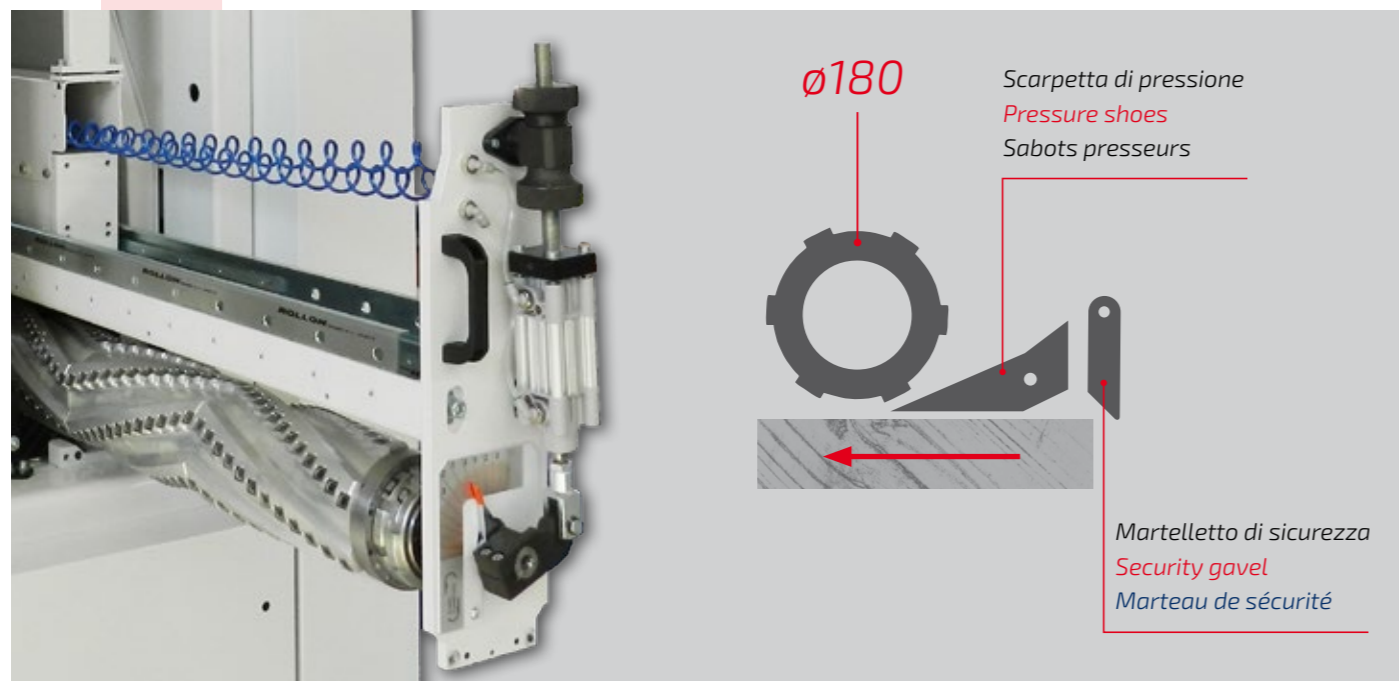

Gruppo operatore Rullo  
*Working unit roller*  
 Groupe de ponçage à Rouleau

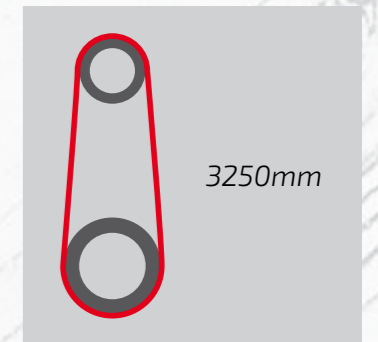
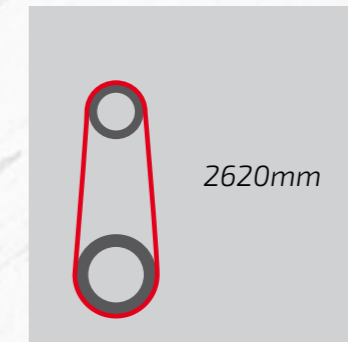

Sistema on-off pneumatico  
*On-off pneumatic system*  
 Système on off pneumatique



Sistema di bloccaggio manuale  
*Manual locking system*  
 Système de verrouillage manuel



Grit-set elettronico  
*Electronic grit-set*  
 Grit-set électronique



Sistema di bloccaggio automatico  
*Automatic locking system*  
 Système de verrouillage automatique

Gruppo operatore Kombi  
**Kombi Group**  
 Groupe de ponçage Kombi

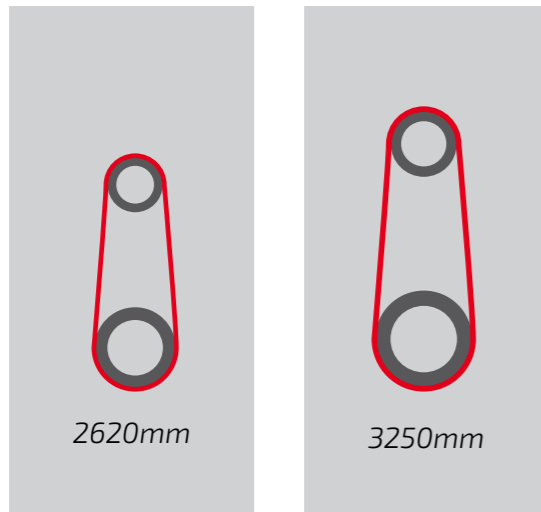

Gruppo operatore Pattino  
**Electronic segmented pad**  
 Groupe de ponçage patin

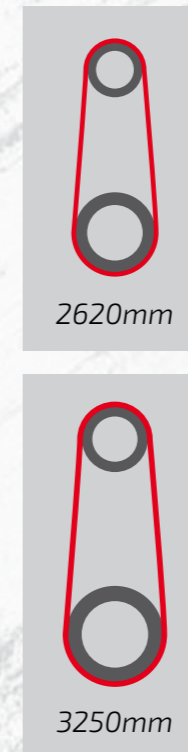

Sistema di bloccaggio manuale  
**Manual locking system**  
 Système de verrouillage manuel

Sistema di bloccaggio automatico  
**Automatic locking system**  
 Système de verrouillage automatique



<b>1</b> Tampone pneumatico <i>Pneumatic pad</i> Patin pneumatique	<b>2</b> 18 mm Tampone settore 18mm <i>Sector pad 18mm</i> Patin secteur 18mm	<b>3</b> 30 mm Tampone settore 30mm <i>Sector pad 30mm</i> Patin secteur 30mm	<b>4</b> PLUS 15 mm Tampone PLUS (escursione 15mm) <i>PLUS pad (excursion 15mm)</i> Patin PLUS (excursion 15mm)
---	---	---	--



Sistema on-off pneumatico  
**On-off pneumatic system**  
 Système on off pneumatique

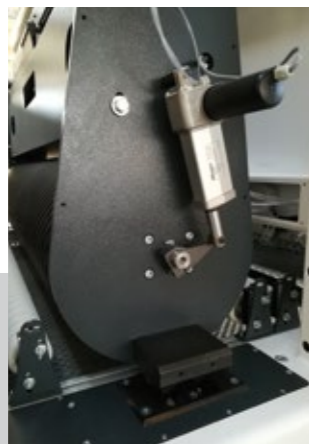

Grit-set elettronico  
**Electronic grit-set**  
 Grit-set électronique



Sistema di bloccaggio manuale  
**Manual locking system**  
 Système de verrouillage manuel



Sistema di bloccaggio automatico  
**Automatic locking system**  
 Système de verrouillage automatique

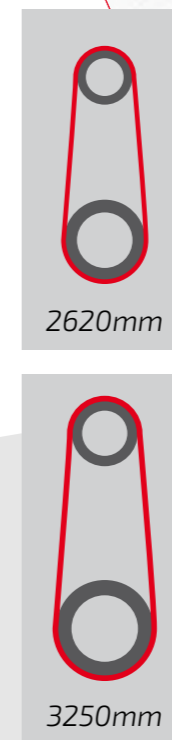

Gruppo operatore Superfinitore  
**Superfinishing pad**  
 Groupe de ponçage de Superfinition



Sistema di bloccaggio manuale  
**Manual locking system**  
 Système de verrouillage manuel

Sistema di bloccaggio automatico  
**Automatic locking system**  
 Système de verrouillage automatique

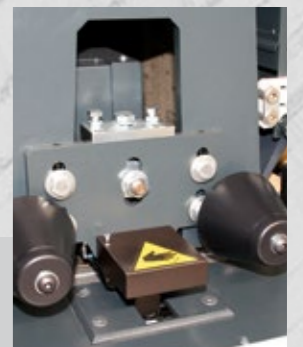

Gruppo operatore trasversale interno  
*Internal electronic cross sanding pad*  
 Groupe de ponçage transversal à l'intérieur

Controlli pneumatici tampone elettronico  
*Pneumatic control for sectioned pad*  
 Contrôles pneumatiques patin électronique

Motore a coppia costante ed inverter vettoriale  
*Constant torque motor and vector inverter*  
 Moteur à couple constant et inverter vectoriel

Soffiatore compatto  
*Compact blower*  
 Soufflette compacte



<b>2</b>	18 mm	Tampone settore 18mm <i>Sector pad 18mm</i> Patin secteur 18mm
<b>3</b>	30 mm	Tampone settore 30mm <i>Sector pad 30mm</i> Patin secteur 30mm
<b>4</b>	PLUS	Tampone PLUS (escursione 15mm) <i>PLUS pad (excursion 15mm)</i> Patin PLUS (excursion 15mm)

Gruppo spazzole tangenziali / sistema planetario  
*Tangential brushes unit / planetary system*  
 Unidad de cepillos tangencial / sistema planetario



Gruppo spazzole tangenziali 1x  
*Tangential brushes unit 1x*  
 Unité de Brosse Tangentielle 1x

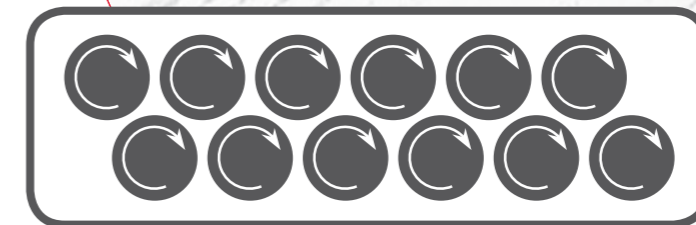

Gruppo spazzole tangenziali 2x  
*Tangential brushes unit 2x*  
 Unité de Brosse Tangentielle 2x

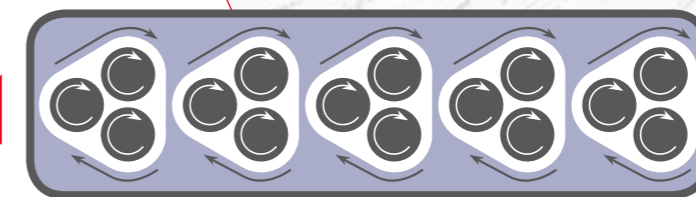

Sistema planetario  
*Planetary system*  
 Système planétaire



Spazzole tangenziali con cambio rapido  
*Tangential brushes with quick change device*  
 Broses tangenciales con dispositivo de cambio rapido

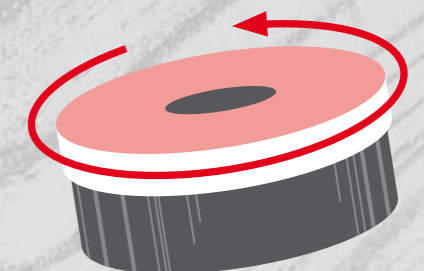



Gruppo spazzola longitudinale  
**Longitudinal brush unit**  
 Unité de brosse longitudinale



Fladder



Tynex



Steel



Tampico



Scotch-brite



Sisal



Depressore interno (taratura variabile, inverter)  
**Internal vacuum fan (setting variable, inverter)**  
 Ventilateur dépression à l'intérieur  
 (réglage variable, inverter)



Valvole proporzionali elettroniche  
**Electronic proportional valves**  
 Vannes proportionnelles



Quadro di controllo pensile  
**Pendulum electronic control unit**  
 Unité de contrôle électronique  
 à pendule



Turbo-soffiatori  
**Turbo rotating blowers**  
 Turbo soufflettes

Soffiatore compatto  
**Compact blower**  
 Soufflette compacte

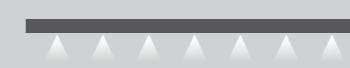
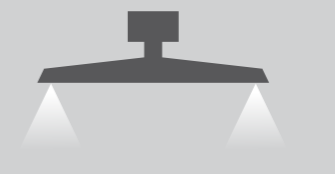

**GREEN ENERGY TECHNOLOGY**

Cuscinetti ad alta efficienza  
**High efficiency ball bearings**  
 Roulements à billes  
 haute efficacité

Posizionatore automatico  
**Automatic positioner**  
 Palpeur automatique

Sistema risparmio aria cappa aspirante  
**System-air saving extractor hood**  
 Système économie air hotte aspirante

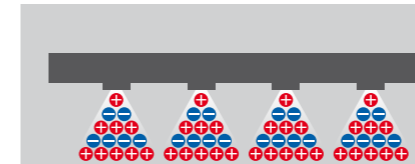

Barra ionizzante  
**Ionizing bar**  
 Barre de ionisation

Luci controllo qualità  
**Quality control special lights**  
 Lampes de control qualité



Spazzola pulizia pezzi  
**Brush for panels cleaning**  
 Brosse nettoyage  
 des pièces

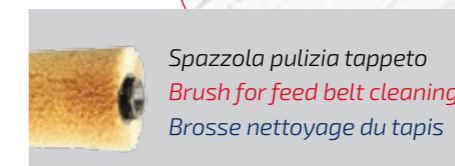

Spazzola pulizia tappeto  
**Brush for feed belt cleaning**  
 Brosse nettoyage du tapis

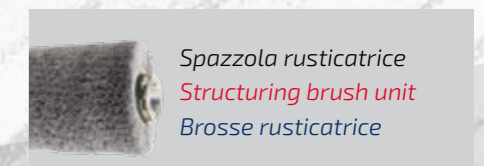

Spazzola rusticatrice  
**Structuring brush unit**  
 Brosse rusticatrice



Rulliere di estensione  
**Rollers table extension**  
 Rouleaux de prolongement table



Transfer ingresso /uscita  
**Transfer infeed/outfeed**  
 Transfert entrée/sortie



Rulliera folle ingresso/uscita  
**Roller conveyor infeed/outfeed**  
 Convoyeur à rouleaux entrée / sortie

Heavy duty machine



MACCHINA BASE  
BASIC MACHINE  
MACHINE DE BASE

- ✓ Versione fino a 6 operatori  
Version up to 6 operators  
Version jusqu'à 6 opérateurs
- ✓ Altezza fissa 900mm  
Fixed height 900mm  
Hauteur table fixe 900mm
- ✓ Spessore di lavoro min/max 3-170/200mm  
Working thickness min/max 3-170/200mm  
Epaisseur de travail min/max 3-170/200mm
- ✓ Dimensione nastri abrasivi (sviluppo) 2620mm  
Abrasive belt (length) 2620mm  
Dimension de la bande abrasive (développement) 2620mm
- ✓ Inverter controllo velocità avanzamento  
Inverter for feed speed control  
Convertisseur vitesse d'entraînement
- ✓ Teleassistenza  
Teleservice  
Teleservice

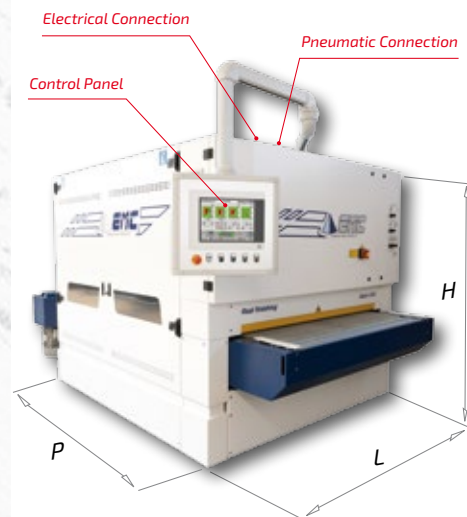

## Giant Line

Layout dedicato  
Dedicated layout  
Layout dédiée



### Need Help?

No problem. Just connect the electronic cable we gave you to the machine. EMC technician will do the rest of the job.

**“Sanding is an Art, which comes from the Heart”.  
And we have a big Heart.**



**EMC**  
Real Finishing

Via Brodolini, 23 - 40026 Imola (Bo) Italy  
Tel. +39 0542 688034 - Fax +39 0542 643959  
E-mail: info@emc-italia.it



 @emcrealfinishing

 emcsrl

[www.emc-italia.it](http://www.emc-italia.it)