

Hammer®



C3 41

Planing, cutting, moulding,
mortising all with one machine

The comeback of the successful combination machine with 410 mm planing width and 900 mm cutting width.



Relaunched in three configuration types with innovative details and optimised for modern woodworking, the C3 41, the C3 41 comfort and the C3 41 perform convince at first glance. The results that can be achieved are impressive and are comparable with what can be expected from solo machines ensured by well-thought-out and practical operating concepts. Regardless of whether planing, sawing, milling or drilling, the extreme ease of use, the precise adjustment options, the quick changeover times and the high quality of workmanship provide investment security for many years!

The solid units and powerful motors ensure long-term reliability. For user-friendliness and fastest change-over times, Hammer offers detailed solutions such as the MF moulder spindle quick-change system, the dual folding planing tables, the MULTIfine adjustment system, the 3-knife automatic cutterblock, the quick adjustment for chip removal and much more. On request, the Hammer C3 41 can also be equipped with the revolutionary Silent-POWER spiral blade cutterblock.

In small workshops, where a permanent all-round access to the machine is not possible, the comfortable rolling carriage allows easy mobility for optimum access to respective application area. For drilling and chiselling work, your Hammer C3 41 can be equipped with a horizontal mortiser.

Variations Models & Your Advantages



C3 41

- » Planing width 410 mm
- » 1800 mm surface planer table length
- » 865 mm cutting length
- » Spindle moulder fence for tools
Ø max. 220 mm
- » MF spindle system (optional)
- » Mortising unit attachment (optional)

C3 41 comfort

- » Planing width 410 mm
- » 1800 mm surface planer table length
- » Cutting length 2050 mm
- » Spindle moulder fence for tools
Ø max. 220 mm
- » MF spindle system (optional)
- » Mortising unit attachment (optional)

C3 41 perform

- » Planing width 410 mm
- » 1800 mm surface planer table length
- » Cutting length 2500 mm
- » Spindle moulder fence for tools
Ø max. 220 mm
- » MF spindle system (optional)
- » Mortising unit attachment (optional)

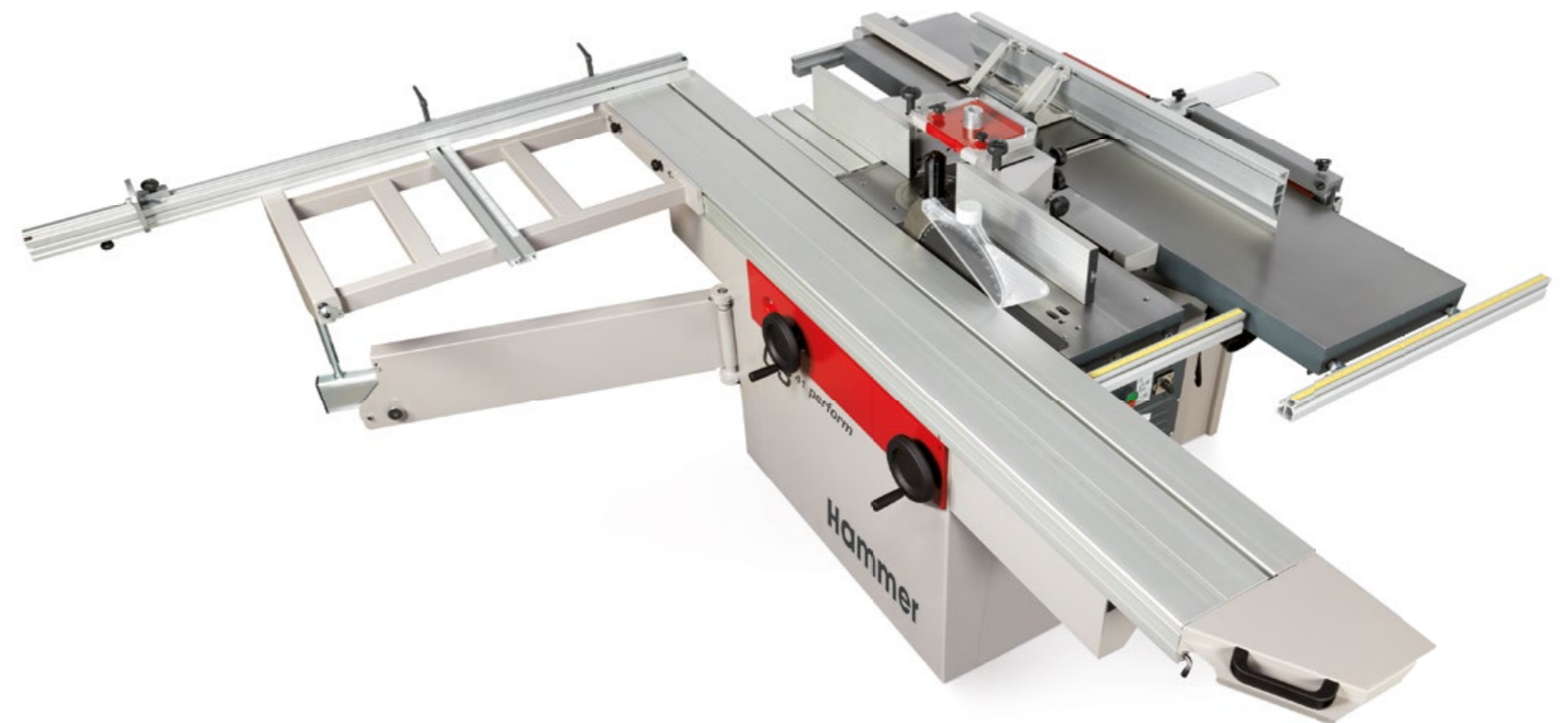

The most important highlights at a glance

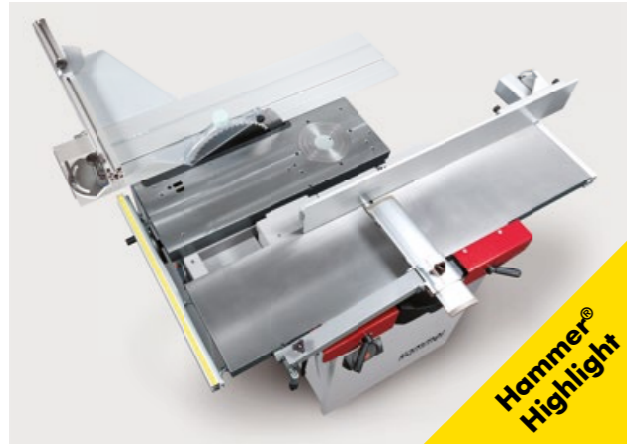

Hammer® Highlight

Planing, sawing and moulding on just 1.5 m²

A small working space does not necessarily mean that your demands of a combination machine must also be small. Quite the opposite in fact – your Hammer C3 41 combination machine fulfils the highest requirements, with perfect results, in the smallest of spaces. Modern machine technology enables quick change-over times - regardless whether planing, sawing, moulding or drilling. The excellent value for money, the user-friendliness, the versatility and the precision are all unbeatable qualities in this class, see for yourself!



Hammer® Highlight

Solid cast iron tables and units

Hammer combination machines are equipped with solid cast iron tables, reliable units and powerful motors that guarantee long-term precision and customer satisfaction.



Hammer® Highlight

Quickest changeover time from planing to sawing, moulding and vice versa

Space-saving and an optimal ergonomic concept: The working tables of your Hammer combination machine tilt towards the middle of the machine, which means very little walking around the machine for you and no restriction to your range of movement. The simultaneous, dual opening and closing of the planing tables saves time and is extremely comfortable. The planing tables lock automatically at the 0° end position.

Hammer®



Hammer - Decision making reliability for many years to come

Durability, functionality and reliability made in Austria – Hammer woodworking machines are top-quality products from Felder. Since 1997, Hammer has been producing high-quality yet affordable woodworking machines for the skilled trades and crafts. The models have been specifically designed for this customer group and are available in the basic, winner and perform configuration, offering price optimised solutions for every requirement. Decades

of experience building machines, Austrian craftsmanship, strict quality standards and tried and tested Felder system solutions, guarantee excellent woodworking machines, the best operating results and customer satisfaction for years to come. From the passionate woodworker to the business user with high demands, with machines from Hammer you are guaranteed reliability and precise woodworking.

... why you should decide on a Hammer machine now:

- » Excellent value for money
- » Decision making reliability for many years to come
- » State of the art machine technology
- » Solid cast iron tables and units
- » High quality, unique detail solutions as part of the standard package
- » Top quality manufacturing with strict quality guidelines
- » User friendly
- » Classic design
- » Quality and precision from AUSTRIA
- » Compact functionality
- » Mobile as an option
- » Minimal space requirement
- » Quickest changeover times

Details that convince



3 knife quick-change, self-setting cutterblock system, the heart of every Hammer planer

The Hammer 3-knife self-setting cutterblock guarantees excellent planed wood surfaces and the greatest ease of use. Since 1987 the cutterblock quick-change system has proven itself a thousand times over and our customers worldwide have saved on expensive additional investment in standard planer cutterblocks. The quick-change cutterblock system is only available from the Felder Group! Your advantages at a glance

- » Planer knife change without adjustments in seconds
- » Disposable knives, each with 2 cutting edges at an inexpensive price
- » No expensive adjustment tools, like those used for standard planing knives, are necessary
- » No second set of planing knives are required during the sharpening cycle

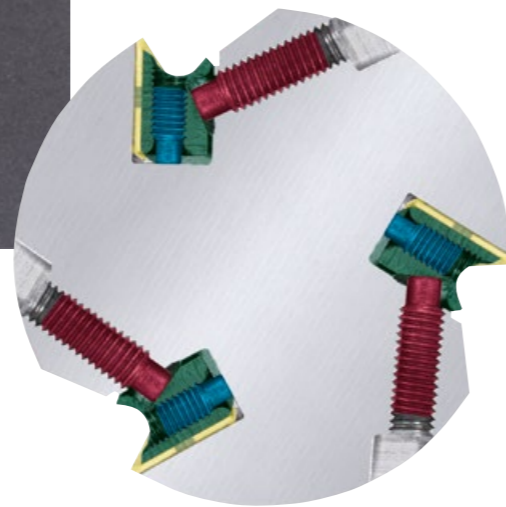

Hammer®

Silent-Power®

The quiet cutterblock

Exclusively only with
Felder®, Format4®

and **Hammer®**



INCREDIBLY QUIET

For the sake of your health and your employees The Silent-Power spiral blade cutterblock reduces noise levels by 50 % (10 db A) when compared with conventional systems.



20 TIMES LONGER BLADE LIFE

saves money The tungsten carbide cutters in the Silent-Power spiral blade cutterblock provide up to twenty times the cutting edge service life of HSS cutters.



FOUR CUTTING EDGES

More „planer knives“ at the same price Each tungsten carbide knife (on the Silent-Power spiral blade cutterblock) has four cutting bevels. Quick-change of the cutter with a simple single „turn“.



LOWER POWER CONSUMPTION

save power costs Regardless of the planing width, the Silent-Power cutterblock uses significantly less power than comparable systems.



TEAR-FREE PLANING RESULTS

Real spiral-knife technology Continuous, pulling cut thanks to the compact arrangement of all cutting edges with optimised cutting angle on the Silent-Power spiral blade cutterblock.



LARGE CHIP SPACE

smallest chipping volumes The chipping flow optimised chip clearance of the Silent-Power spiral blade cutterblock and the short cutting bevels guarantee the best possible chip transport and the lowest chip volumes.



IN-HOUSE PRODUCTION

Innovation made in Austria The Silent-Power spiral blade cutterblock is manufactured 100% in the factory in Hall i. T., Austria. Local craftsmanship and uncompromising manufacturing standards guarantee the top quality „Made in Austria“.



PATENTED SINCE 2012

Often copied, but never equalled Almost 10 years ago, the Silent-Power spiral blade cutterblock has set new standards on the market in terms of noise reduction, quality and efficiency and remains unparalleled to this day.



Solid planer tables for absolute precision

The strong ribbed Hammer planer and thicknesser tables are made from solid cast iron and ensure perfect precision in every situation. The width of the planing table equates to the planing width, which means that workpieces can be planed safely across the full length of the planing table.



Quick and simple: Depth of cut adjustment when planing

The large adjustment handle for the planing depth of cut is integrated perfectly into the machine design. The depth of cut adjustment of up to 4 mm can be carried out quickly, simple and precisely without having to release any locks. That is top class operating comfort.

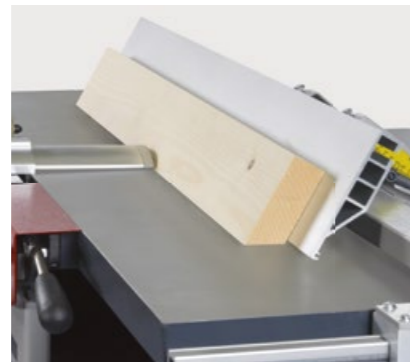

The planer fence for exact joining and bevelling

The planer fence can be moved and fixed to any position across the width of the table. The planing fence is made of aluminium and can be tilted and fixed at any position between 90°–45°. Fine adjustable end stops ensure an exact 90° and 45° position. The precise workpiece guiding whilst joining and bevelling is helped by the long planing fence.



As and when required: Adapt the table size to the workpiece dimensions

Processing long and heavy workpieces without assistance - no problem with a Hammer! The Hammer table extension system, which has been tried and tested worldwide a thousand times over, allows you to assemble table extensions without tools in just a few steps. The support surface can be extended by 400 or 800 mm on each side of the working table. This means an extension of your table length by up to 1 600 mm!

Hammer®



Dual opening of the planer tables

Space-saving and an optimal ergonomic concept: The working tables of your Hammer combination machine tilt towards the middle of the machine, which means very little walking around the machine for you and no restriction to your range of movement. The simultaneous, dual opening and closing of the planing tables saves time and is extremely comfortable. The planing tables lock automatically at the 0° end position.



Maximum thickening height for large dimensioned requirements

The maximum thickening height of 225 mm is a guarantee for the perfect processing of large and heavy workpieces. An even more precise, tenth of a millimetre, accurate adjustment of the thickening height is possible with the optional handwheel and integrated digital clock.



Perfect extraction technology - a clean solution

The aerodynamically optimized construction of the dust extraction hood with its ample chip space guarantees an ideal chip extraction and clean working surface.

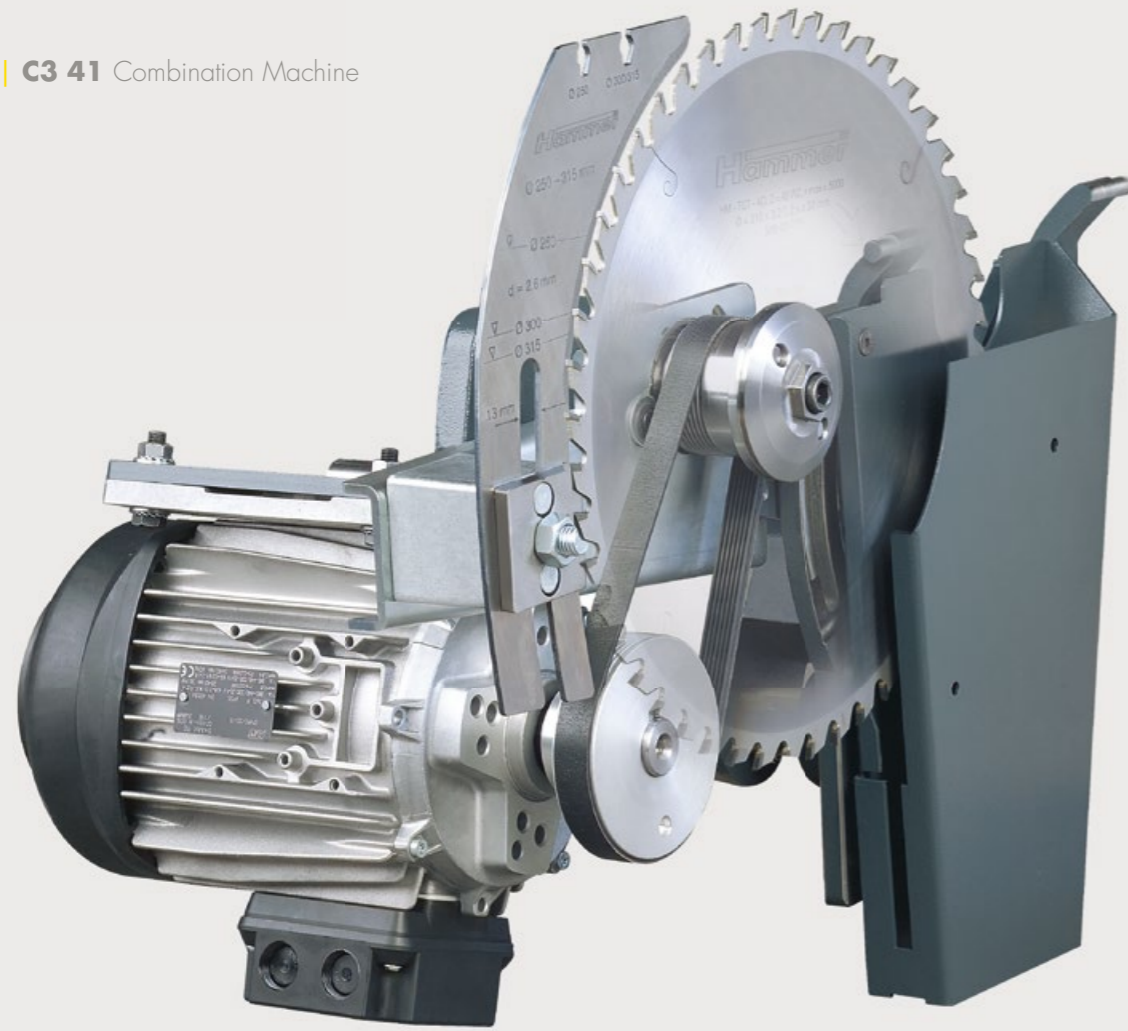

Stable-compact-precise, the Hammer saw aggregate

The Hammer saw aggregate impresses with smoothness, precision and extreme user friendliness. The large cutting height of 103 mm leaves nothing to be desired. Saw blades with up to 315 mm diameter can be lowered completely below the level of the saw table. The saw blade is simple to access and can be changed with ease.



Grooving, slot and tenoning with the saw

Every hammer panel saw can be equipped with a preparation for the use of specialised dado tooling. The dado tool can be fitted to the saw arbour and makes it possible to make various width grooves, tenons and slots of between 8 and 19.5 mm in width.



Scoring unit for laminated workpieces

The scoring unit ensures chip free cuts in laminated workpieces. The cutting width of the two part scoring blade can be adjusted accurately to the tooth width of the main saw blade using a ring set. The drive of the scoring blade is done mechanically, with it rotating in the opposite direction to the main saw blade.



Saw blade tilt 90°-45°

The continuously variable tilt range between 90 and 45 ensures precise mitre cuts. End stops at the 90° and 45° position ensure the exact positioning of the settings. A large scale allows precise positioning and easy read-out of the corresponding values.



Rip fence on the saw table

The rip capacity on the saw table is adjustable between 0 and 900 mm. The scale that is integrated into the rail ensures the exact setting of the aluminium rip fence to the position required. The aluminium fence can be positioned in any position along the cutting direction - when processing long workpieces you get a better feed of the workpiece and ensure a high processing precision.

When carrying out angled cuts with a tilted saw blade it is possible to move the fence from the horizontal to the flat position. The narrow fence edge then enables the rip cutting of very thin workpieces.

Stability and operating smoothness - the Hammer spindle moulder unit

High precision with standard moulding work or use of heavy tools - The Hammer spindle moulder unit guarantees extreme smoothness and precision. The spindle diameter is 30 mm. The ergonomically laid out operating elements and the smooth tool change convinces with every application, day after day. Four well spaced, selectable speeds, 3000/6000/8000 and 10,000 rpm, cover the optimum speeds of various different spindle tool diameters. An important detail is standard with Hammer: the forward and reverse run of the spindle for your safety when moulding.





moulder spindle

The standard: Moulder spindle-Ø 30 mm for standard moulding tools. Ideal for all „classic“ moulding work.



MF Spindle shaft quick change system

Without losing any settings, just a few turns of your hand allows you to swap spindles of varying diameters.

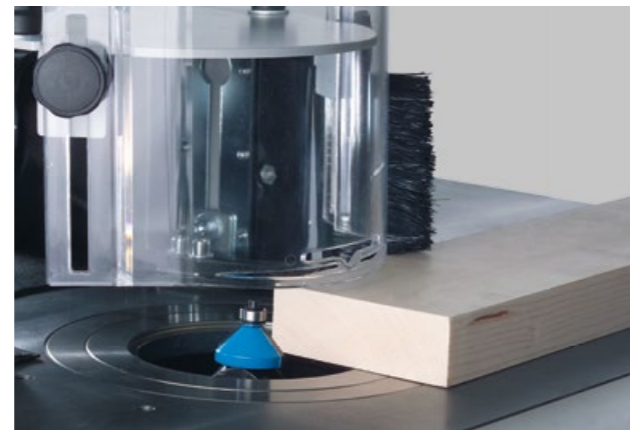

Spindle fence: simple handling, maximum safety and precision

The Hammer spindle fence is suitable for tools with a diameter up to 220 mm. Both of the anodised aluminium fences can be easily set to the spindle moulder tool diameter being used. The adjustment for the depth of cut when moulding can be made on the outfeed fence plate with a range of -5 mm to +25 mm. The extraction connection diameter for the chip extraction on the fence is 120 mm.

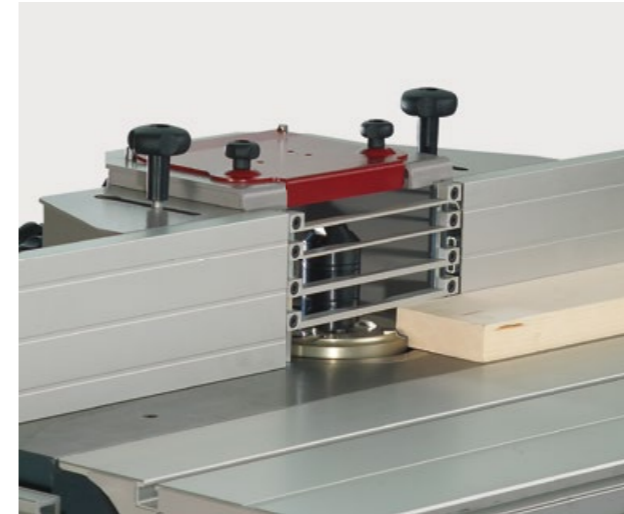
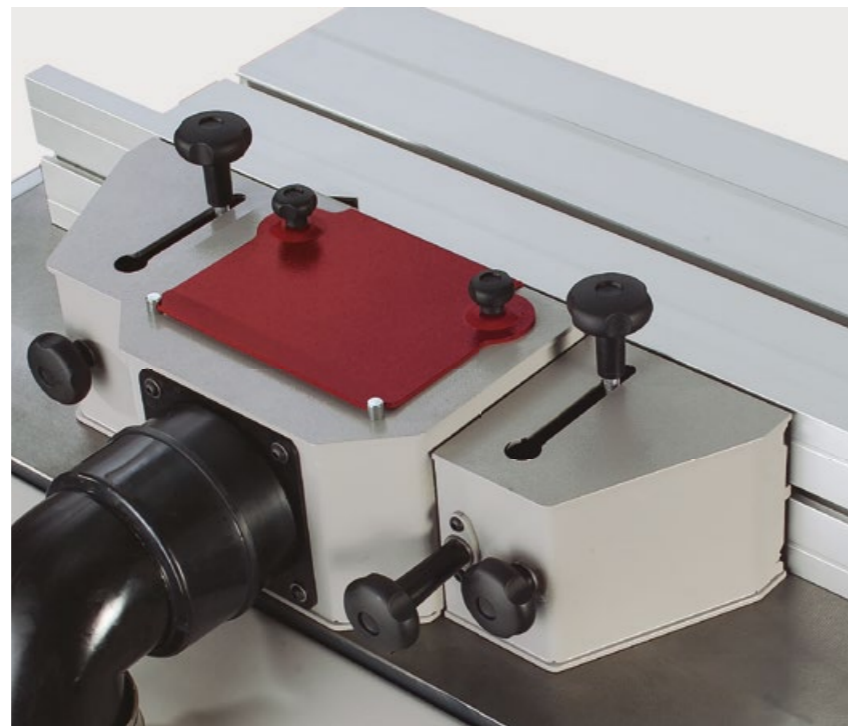

Safety Bar Guides

The safety bar guides, great for „end-grain“ work (optional).



The MULTI-fine adjustment system

Without losing any settings, just a few turns of your hand allows you to swap spindles of varying diameters.



The aluminium sliding table, the heart of every panel saw

The aluminium sliding table gives the precision from the first cut. Guaranteed Hammer stability and precision: the strong ribbed, milled and anodised aluminium hollow-chamber profile of the sliding table in combination with the high quality guiding system ensures maximum accuracy and precision!



The Mortising Unit

The mortising unit is mounted to the planer side.



Outrigger table for heavy workpieces

The outrigger table provides additional surface support and precision when processing large dimensioned and heavy workpieces. In combination with a 900 or 1300 aluminium crosscut fence and the crosscut extension your Hammer with outrigger table becomes a complete, large panel saw.



Locking pin

Angles at 5 degree intervals and at 22.5° can be cut with the help of the index locating pins.



Crosscut fence for precise mitre cuts

Adjustable to any position between +45° and -45°, the crosscut fence ensures precise angled and mitre cuts. A scale integrated into the aluminium sliding table makes it easy to set precisely. The end stop for the 90° position guarantees absolute precision with repeat settings. The scale on the 900 mm long aluminium crosscut fence is angled towards the operator and makes it easy to comfortably read the exact setting. In combination with the crosscut stop with integrated magnifying glass, highly precise settings and as such absolutely exact results are guaranteed.

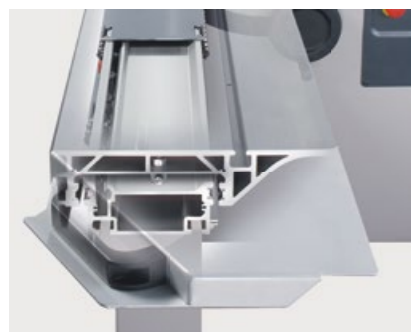

Format sliding table perform

The „perform models“ are constructed for maximum load bearing capacity and equipped with an industrial sliding table. The smooth precision guiding system guarantees absolute precision when cross cutting, rip cutting and formatting.



Minimal space requirement - mobile in every workshop

Hammer woodworking machines are an absolute spacial wonder. The efficient machine design of a Hammer means that space can be found in even the smallest of workshops. As an option a rolling carriage can be fitted to every Hammer, offering mobility and freeing up additional space.

Technical specifications

Electrics	C3 41	C3 41 comfort	C3 41 perform
001 3x 400 V motor voltage	S	S	S
003 1x 230 V motor voltage, motor power 4.0 HP (3.0 kW) S6/40%	O	O	O
004 50 Hz motor frequency	S	S	S
005 60 Hz motor frequency	W	W	W
007 Motor power 4.0 HP (3.0 kW) S6/40%	S	S	S
008 Motor power 5.5 HP (4.0 kW) S6/40 %;	O	O	O
11 Forward and reverse run	S	S	S

Planing unit and cutterblock	C3 41	C3 41 comfort	C3 41 perform
42 3 knife quick-change, self-setting cutterblock system	S	S	S
43 3-knife standard cutterblock	O	O	O
44 Silent-POWER® spiral cutter-block	O	O	O
- Anodised planer fence tilts from 90°-45°	S	S	S
- Length of surface planer fence	150 x 1150 mm	150 x 1150 mm	150 x 1150 mm
- Surface planing width	16 1/8" (410 mm)	16 1/8" (410 mm)	16 1/8" (410 mm)
- Planer table length	1800 mm	1800 mm	1800 mm
- Number of knives - Silent-POWER spiral cutterblock	62	62	62
- Maximum depth of cut	1/2" (4 mm)	1/2" (4 mm)	1/2" (4 mm)

Planer and Feed Drive	C3 41	C3 41 comfort	C3 41 perform
- Thicknessing width	15" (406 mm)	15" (406 mm)	15" (406 mm)
- Thicknessing height min.-max. 4-225 mm;	S	S	S
- Thicknessing table length in mm	600 mm	600 mm	600 mm
- Min. workpiece length in mm	145	-	145
- Synchronous feed speed 6 m/min. (50 Hz)	S	S	S

Saw Unit	C3 41	C3 41 comfort	C3 41 perform
74 Mechanically driven scoring unit Ø 80 mm	O	O	O
76 Rip capacity	0-900 mm	0-900 mm	0-900 mm
82 Dado capability for tooling up to 3/4" (19.5 mm) width	O	O	O
- Main saw blade Ø 250-315 mm, saw blade rotation speed 4800 rpm	S	S	S
- Saw/spindle moulder table	860 x 300 mm	860 x 300 mm	860 x 300 mm
- Saw blade tilt 90°- 45°, max. cutting height 103 mm	S	S	S

Spindle moulder unit and spindle fence		C3 41	C3 41 comfort	C3 41 perform
100	Moulder spindle Ø 30 mm, 100 mm Nutzhöhe 100 mm maximum above table operating height	S	S	S
101	MF spindle system - Changeable Ø 30 mm spindle shaft, 100 mm useable height	O	O	O
102	MF spindle system - Changeable Ø 32 mm spindle shaft, 100 mm useable height	O	O	O
103	MF spindle system - Changeable Ø 35 mm spindle shaft, 100 mm useable height	O	O	O
104	MF spindle system - Changeable Ø 1 1/4" spindle shaft, 100 mm useable height	O	O	O
105	MF spindle system - Changeable Ø 50 mm spindle shaft, 100 mm useable height	O	O	O
108	MF spindle system - Changeable spindle shaft with collet chuck	O	O	O
113	MULTI fine adjustment system with 450 mm fence plates	O	O	O
-	Speed 3000/6000/8000/10,000 rpm	S	S	S
-	Spindle fence 220 for tool Ø max. 220 mm	S	S	S
-	Moulder spindle 90° with height adjustment at the front of the machine	S	S	S
-	Max. tool diameter that can be lowered below the table at 90°	7" (180 mm)	7" (180 mm)	7" (180 mm)

Anodised sliding table		C3 41	C3 41 comfort	C3 41 perform
130	Format sliding table 800 mm, cutting length 865 mm*	S	-	-
131	Format sliding table 1250 mm, cutting length 1300 mm*	O	-	-
132	Format sliding table 2000 mm, cutting length 2050 mm	O	S	-
133	Format sliding table 2500 mm, cutting length 2500mm, edging shoe*	-	-	S

Outrigger tables and crosscut fences		C3 41	C3 41 comfort	C3 41 perform
160	1100 outrigger table	O	S	-
161	Outrigger table 1250	-	-	S
163	Mitre index system for the outrigger table (#160/161)	O	S	O
164	900 mm crosscut fence for all sliding table lengths	S	O	O
165	750 mm telescopic extension for the crosscut fence (#164)	O	O	O
166	1300 mm crosscut fence for the 1100 outrigger table (#160)	O	S	-
168	1300 mm outrigger crosscut fence instead of 900 mm (#160)	O	-	-
169	2600 mm crosscut fence for the 1250 outrigger table	-	-	S

Mortising unit		C3 41	C3 41 comfort	C3 41 perform
190	Mortising table	O	O	O
191	Mortising chuck 0-16 mm	O	O	O

Weight		C3 41	C3 41 comfort	C3 41 perform
-	Weight kg (with standard configuration) net/gross	720 kg	720 kg	810 kg

Important accessories		C3 41	C3 41 comfort	C3 41 perform
210	Rolling carriage without lifting bar	O	O	O
211	Lifting bar	O	O	O
212	Tilt away device for power feeders	O	O	O
221	Transport preparation for overseas transport	O	O	O
223	Heat treated pallet in accordance with IPPC regulations	W	W	W

Product range

Combination machines C3 31



Combination machines C3 41



Saw-Shaper B3



Planer-Thicknesser A3



Circular Saws & Sliding Table Panel Saws K3, K4



F3 Spindle Moulder



Bandsaws



Hammer®

Hammer Affordable functionality and reliability

Since 1997 the Felder Group has been producing high quality yet affordable woodworking machines with the brand Hammer for do-it-yourselfers and small businesses. Robust, durable, space-saving and precise in its operation. Quality products that simply make woodworking fun.

FELDER GROUP

KR-Felder-Straße 1
A-6060 HALL in Tirol

🇬🇧 Tel. 01908 635000
www.hammer.uk
[Contact](#)

🇮🇪 Tel. 0906625756
www.hammer.ie
[Contact](#)

🇮🇳 Tel. 1800 274 3040
www.hammer.in
[Contact](#)

🌐 Tel. +43 5223 58500
www.hammer.int
[Contact](#)