

UNITÀ AGGREGATE
AGGREGATE UNITS



HITECO
HIGH TECHNOLOGY COMPONENTS

Componenti ad **alta tecnologia** per produttori di macchine utensili.

--
High-tech components for machine tool manufacturers.

Hiteco è specializzata nella progettazione e realizzazione di componenti elettromeccanici industriali ad alta tecnologia per le macchine utensili.

Elettromandri A.T.C., elettromandri M.T.C., teste birotative, teste di foratura ed aggregati.

--
Hiteco is specialized in design and manufacture of high technology industrial electromechanical components for machine tools. **A.T.C. electrospindles, M.T.C. electrospindles, birotary heads, boring units and aggregates.**



Hiteco si propone sul mercato internazionale con un'ampia gamma di prodotti per la lavorazione di: **legno, plastica, materiali avanzati, vetro, pietra e metallo.**

--
Hiteco offers a wide range of products on international market for **wood, plastic, advanced materials, glass, stone and metal processing.**



Hiteco nasce nel 1977 come divisione interna di **SCM Group**, azienda leader mondiale nella costruzione di macchine utensili per la lavorazione di una vasta gamma di materiali, realizzando un percorso di crescita esponenziale. Diventa nel 2008 **un'unità di profitto per servire il mercato terzi**. Oggi realizza prodotti di riferimento nel mercato dei componenti, diventando uno tra i più importanti player mondiali nel settore.

--
Hiteco founded in 1977 as an internal division of the **SCM Group**, leading company in machine tools construction for processing a wide range of materials, had an increasingly exponential growth. In 2008 it become **a profit unit for external customers**. Today Hiteco offers key products for the components market, becoming one of the most important world players in the sector.



Una **presenza capillare** per un **servizio best-in-class e worldwide.**

--
A capillary presence for a **best-in-class** and **worldwide service.**

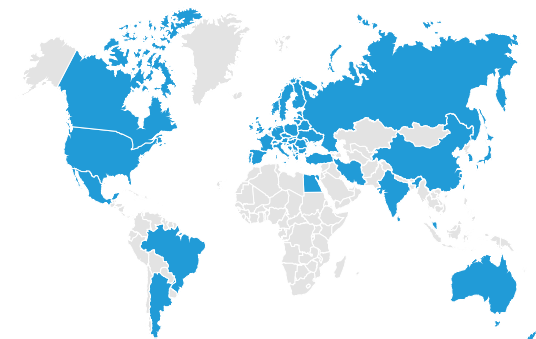

La distribuzione capillare dell'azienda risponde alla volontà di Hiteco di essere vicina al cliente con la presenza sul territorio di **tecnici specializzati** che sono garanzia di una risposta

estremamente rapida e professionale: non solo per ridurre fermi macchina e problemi alla produzione, ma anche per creare valore aggiunto con la proposta di soluzioni efficaci ed innovative. Questa attenzione, oltre ai ridotti tempi di consegna, è uno dei motivi che ha portato Hiteco ad avere la più alta **customer satisfaction** nel mercato internazionale.

--
The widespread distribution of the company responds to the desire of Hiteco to be close to the customer with the presence of **specialized technicians** on the territory who guarantee an extremely rapid and professional response: not only to reduce machine downtimes and production problems, but also to create added value with the proposal of effective and innovative solutions. Such care, in addition to reduced delivery times, is one of the reason that led Hiteco to have the highest **customer satisfaction** on the international market.



L'aggregato ideale per qualsiasi lavorazione

The ideal aggregate for any working

<p>Aggregato BLADE per tagliare con utensile lama fino a 300 mm.</p>	<p>Aggregate BLADE to cut with blade tool up to 300 mm.</p>	<p>Aggregato ONE ideale per fresatura/foratura.</p>	<p>Aggregate ONE perfect for milling/boring.</p>
---	--	--	---



<p>Aggregato FOUR 4 uscite per fresatura/foratura.</p>	<p>Aggregate FOUR 4 outputs for milling/boring.</p>	<p>Aggregato TWIN PRO 2 uscite per fresatura/foratura. Alta velocità di rotazione e ingombro ridotto (ideale per scasso serratura).</p>	<p>Aggregate TWIN PRO 2 outputs for milling/boring. High rotational speed and recessed output (perfect for lock mortising).</p>
---	--	--	--



<p>Aggregato THREE 3 uscite per fresatura/foratura.</p>	<p>Aggregate THREE 3 outputs for milling/boring</p>	<p>Aggregato COPY per eseguire lavorazioni costanti su superfici irregolari.</p>	<p>Aggregate COPY for achieve constant machining on irregular surfaces.</p>
--	--	---	--



<p>Aggregato VERTICAL BORE 3 uscite per la foratura. Studiato per la creazione delle cerniere nei pannelli.</p>	<p>Aggregate VERTICAL BORE 3 outputs for boring. Studied for pot hinges during panels production.</p>	<p>Aggregato VERTICAL BORE 5 uscite per la foratura. Ideale per la creazione di file di fori nei pannelli.</p>	<p>Aggregate VERTICAL BORE 5 outputs for boring. Perfect for creating rows of holes during panels production.</p>
--	--	---	--

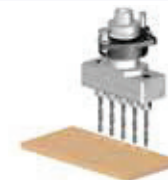

<p>Aggregato TWIN con 2 uscite per fresatura/foratura o fresatura/foratura e taglio.</p>	<p>Aggregate TWIN double output for milling/boring or milling/boring and cutting.</p>	<p>Aggregato TILT fresatura/foratura o taglio con inclinazione da 0° a 360°.</p>	<p>Aggregate TILT milling/boring or cutting with 0°-360° adjustable tilting.</p>
---	--	---	---

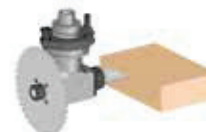

<p>Aggregato NOTCH per finire e squadrare gli angoli interni.</p>	<p>Aggregate NOTCH for finishing and squaring internal corners.</p>	<p>Aggregato DSIDE per fresatura/foratura da sotto. Evita di capovolgere il pezzo.</p>	<p>Aggregate DSIDE milling/boring from bottom side. Avoid the need of overturning workpiece.</p>
--	--	---	---



<p>Aggregato HORIZONTAL LOW BORE 3 uscite per la foratura orizzontale. Ideale per il nesting.</p>	<p>Aggregate HORIZONTAL LOW BORE 3 outputs for horizontal boring. Perfect for nesting.</p>	<p>Aggregato MULTIBLADE ideale per l'utilizzo contemporaneo di più lame</p>	<p>Aggregate MULTIBLADE ideal for simultaneous use of multiple blade tools</p>
--	---	--	---



Principali applicazioni

Main applications



PORTE & FINESTRE
DOORS & WINDOWS

TWIN PRO
PAG. 18

NOTCH
PAG. 30

LIBRERIE
LIBRARIES

COPY
PAG. 42

ONE BLADE
PAG. 14

HORIZONTAL LOW BORE
PAG. 38

VERTICAL BORE - 5 OUTPUTS
PAG. 36

VERTICAL BORE - 3 OUTPUTS
PAG. 34

SCALE
STAIRS

THREE
PAG. 20

TWIN PRO
PAG. 18

FOUR
PAG. 22

TAVOLI & SEDIE
TABLES & CHAIRS

TILT
PAG. 24

ONE
PAG. 12

TWIN
PAG. 16

COPY
PAG. 42

PARETI & TRAVI
WALLS & BEAMS

TWIN PRO
PAG. 18

MULTIBLADE
PAG. 32

TILT BLADE
PAG. 26

TILT
PAG. 24

CUCINE
KITCHENS

VERTICAL BORE - 5 OUTPUTS
PAG. 36

VERTICAL BORE - 3 OUTPUTS
PAG. 34

DSIDE
PAG. 28

Principali applicazioni

Main applications



ESTRUSI IN ALLUMINIO EXTRUDED ALUMINIUM

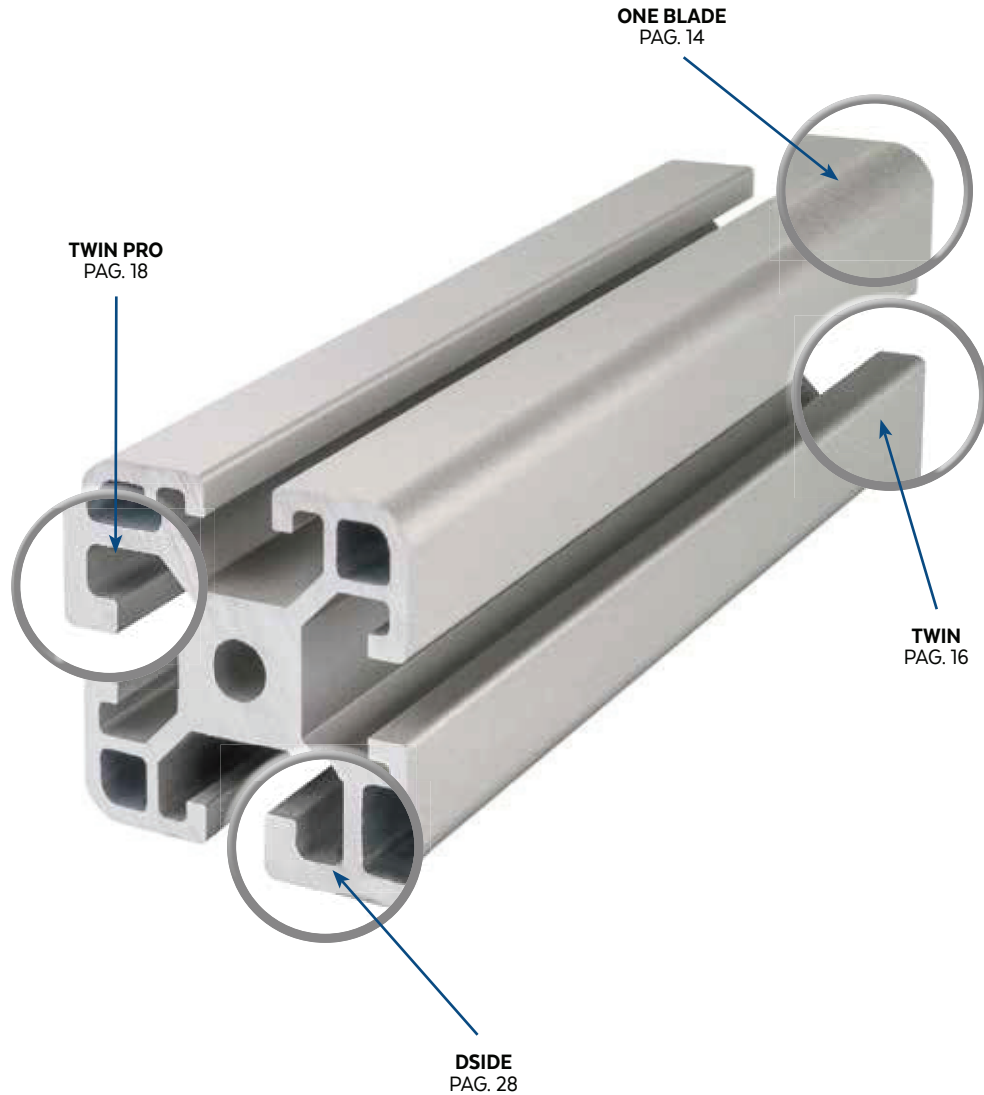

INFISSI IN PVC PVC WINDOWS

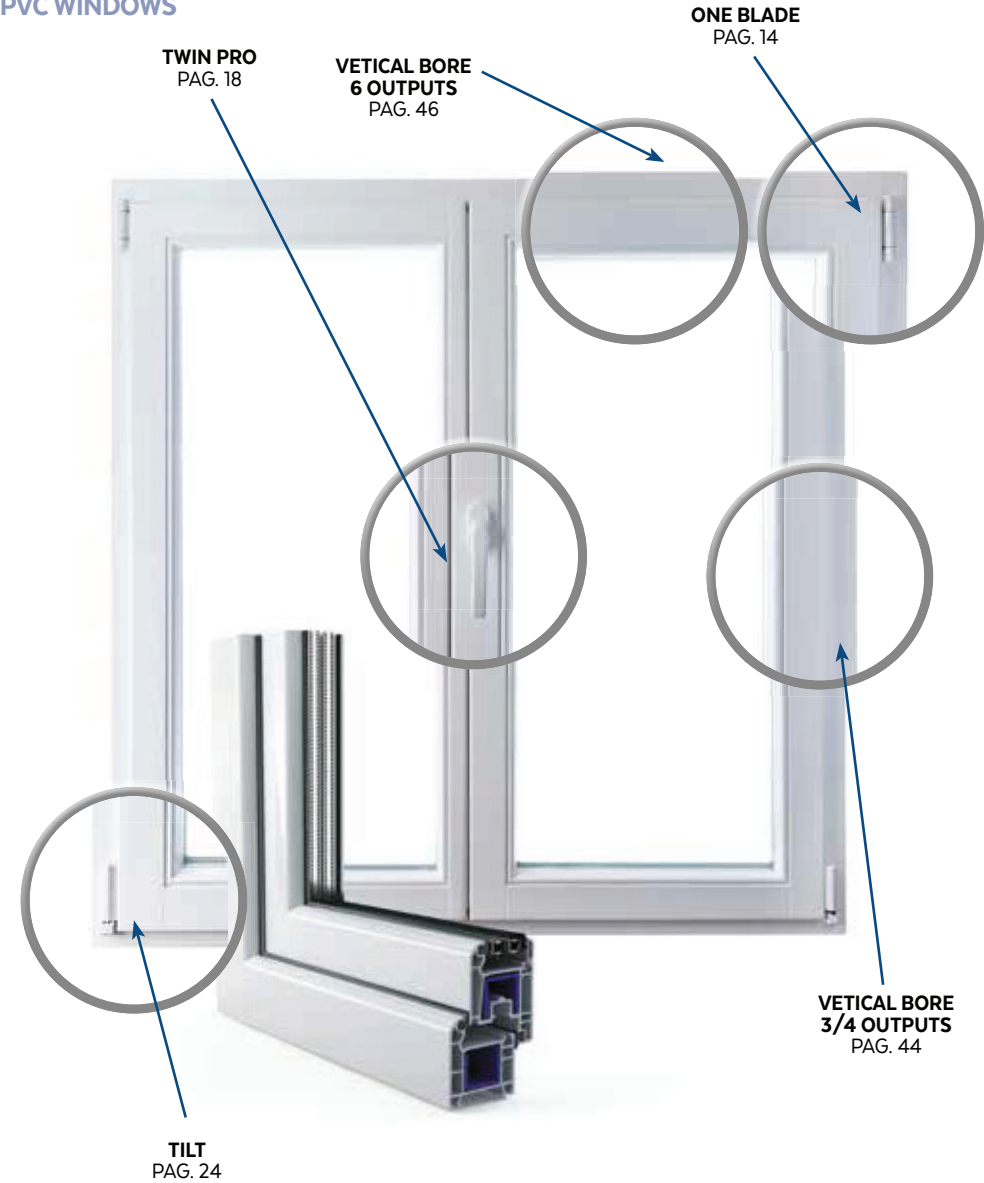

La perfezione tecnologica in ogni dettaglio

Technological perfection
in every detail

Hiteco, in completamento alla fornitura degli aggregati, è in grado di proporre il pacchetto completo (che comprende elettromandrino e asse "C"), per soddisfare le richieste più esigenti e lavorazioni gravose.

In complement to the wide supply of aggregates, Hiteco is able to propose the complete package (which includes the electro spindle and "C" axis) to meet the most demanding and heavy machining requirements.



INDICE / INDEX

ONE	p. 12
ONE BLADE	p. 14
TWIN	p. 16
TWIN PRO	p. 18
THREE	p. 20
FOUR	p. 22
TILT	p. 24
TILT BLADE	p. 26
DSIDE	p. 28
DSIDE COMPACT	p. 30
NOTCH BLADE	p. 32

MULTIBLADE	p. 34
VERTICAL BORE - 3 OUTPUTS	p. 36
VERTICAL BORE - 5 OUTPUTS	p. 38
HORIZONTAL LOW BORE	p. 40
NOTCH	p. 42
COPY	p. 44

VERTICAL BORE 3 - 4 OUTPUTS	p. 46
VERTICAL BORE 6 OUTPUTS	p. 48

Copyright c Hiteco. Tutti i diritti riservati
Copyright c Hiteco. All rights reserved

Hiteco si riserva il diritto di apportare migliorie sulle tecnologie e i modelli presentati nel catalogo
Hiteco reserves the right to make improvements to the technologies and models presented in the catalog

ONE

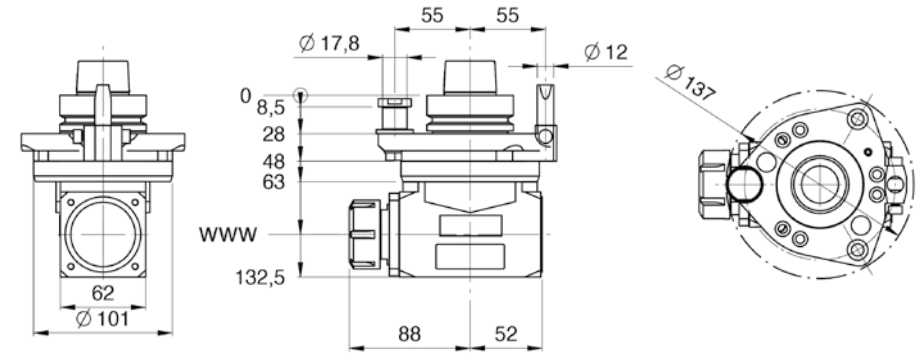

ONE ER32

Attacco mandrino / Spindle coupling		HSK 63F
Velocità max. rotazione mandrino / Max spindle speed	giri/min rpm	10850*
Velocità max. rotazione utensile / Max tool speed	giri/min rpm	15500*
Senso rotazione mandrino / Spindle rotation direction		vedi disegno see drawing
Possibilità inversione rotazione mandrino Possibility to change electrospindle direction		NO
Rapporto di trasmissione / Gear ratio		1:1.43
Attacco utensile / Tool coupling		ER32DX
Diametro codolo / Tool shank diameter	mm	2 - 20
Diametro lama / Blade diameter	mm	-
Diametro foro lama / Hole blade diameter	mm	-
Peso / Weight	Kg	4,2
Lubrificazione / Lubrication		Grasso Grease
Temperatura max. / Max temperature	°C/F	75 / 167
Orientamento angolare / Aggregate rotation		0°/360° continuo continuous
Connessione asse C / C axis connection type		H1

* vedere manuale / see user manual

CONFIGURABILITÀ / CONFIGURABILITY

WWW-X-YYY-ZZ

ALTEZZA / HEIGHT	WWW
100	100
145	145
180	180
ATTACCO UTENSILE / TOOL HOLDER	X
ER32	C
ATTACCO MANDRINO / SPINDLE INTERFACE	YYY
HSK 63F	63F
HSK 63E	63E
ISO 30	I30
ISO 30 SCM*	I3S
RIFERIMENTI / C AXIS CONNECTION	ZZ
SCM HITECO 1 PIN	H1
SCM 3 PIN - SCM1 PIN - MORBIDELLI 3PIN - 1PIN	S3/(S1)
ISO 30 SCM*	SS*
BUSELLATO	BU
BIESSE	BI
HOLZ-HER	Z1
FELDER	FE
CMS	CM
SCM 1 PIN OLD	D1
SCM 2 PIN OLD	D2
SCM/HITECO 3 PIN (con ut. pneumatiche with air supplies)	H3
SCM/MORBIDELLI 3 PIN (con ut. pneumatiche with air supplies)	SP
HOMAG (con ut. pneumatiche with air supplies)	HO



* I3S compatibile solo con SS / I3S only compatible with SS

ONE BLADE

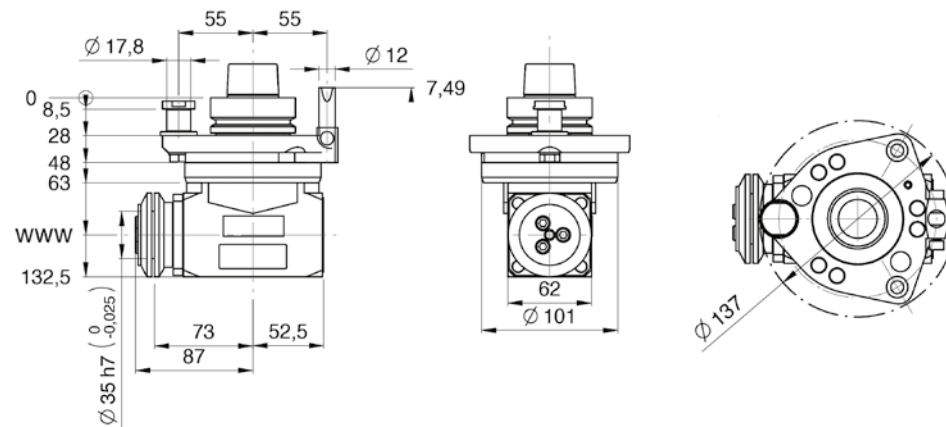

ONE BLADE

Attacco mandrino / Spindle coupling		HSK 63F
Velocità max. rotazione mandrino / Max spindle speed	giri/min rpm	15500*
Velocità max. rotazione utensile / Max tool speed	giri/min rpm	10850*
Senso rotazione mandrino / Spindle rotation direction		vedi disegno see drawing
Possibilità inversione rotazione mandrino Possibility to change electrospindle direction		SI YES
Rapporto di trasmissione / Gear ratio		1:0.7
Attacco utensile / Tool coupling		-
Diametro codolo / Tool shank diameter	mm	-
Diametro lama / Blade diameter	mm	D = 240**
Diametro foro lama / Hole blade diameter	mm	D = 35
Peso / Weight	Kg	4,4
Lubrificazione / Lubrication		Grasso Grease
Temperatura max. / Max temperature	°C/F	75 / 167
Orientamento angolare / Aggregate rotation		0°/360° continuo continuous
Connessione asse C / C axis connection type		H1

* vedere manuale / see user manual

** dipende dalla posizione rif.angolare / depends on pin-plate angular position

CONFIGURABILITÀ / CONFIGURABILITY

WWW-X-YYY-ZZ

ALTEZZA / HEIGHT WWW

100	100
145	145
180	180

ATTACCO UTENSILE / TOOL HOLDER X

BLADE	D
PROLOCK	G

ATTACCO MANDRINO / SPINDLE INTERFACE YYY

HSK 63F	63F
HSK 63E	63E
ISO 30	I30
ISO 30 SCM*	I3S



RIFERIMENTI / C AXIS CONNECTION ZZ

SCM HITECO 1 PIN	H1
SCM 3 PIN - SCM 1 PIN - MORBIDELLI 3PIN - 1PIN	S3/(S1)
ISO 30 SCM*	SS*
BUSELLATO	BU
BIESSE	BI
HOLZ-HER	Z1
FELDER	FE
CMS	CM
SCM 1 PIN OLD	D1
SCM 2 PIN OLD	D2
SCM/HITECO 3 PIN (con ut. pneumatiche with air supplies)	H3
SCM/MORBIDELLI 3 PIN (con ut. pneumatiche with air supplies)	SP
HOMAG (con ut. pneumatiche with air supplies)	HO

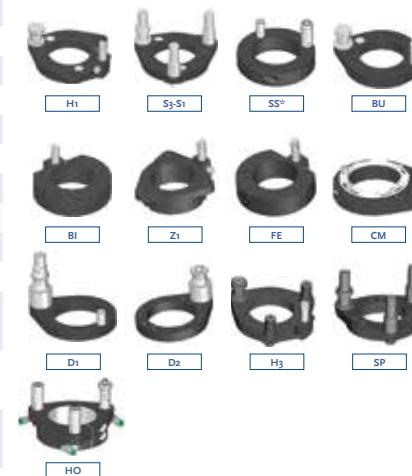

* I3S compatibile solo con SS / I3S only compatible with SS

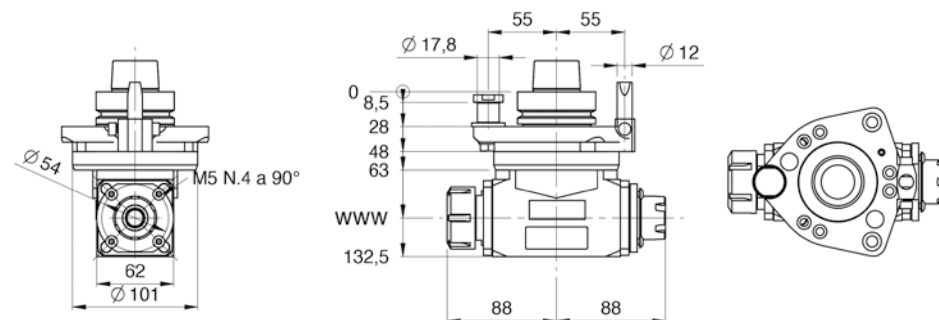

TWIN ER32-ER25B

Attacco mandrino / Spindle coupling		HSK 63F
Velocità max. rotazione mandrino / Max spindle speed	giri/min rpm	10850*
Velocità max. rotazione utensile / Max tool speed	giri/min rpm	15500*
Senso rotazione mandrino / Spindle rotation direction		vedi disegno see drawing
Possibilità inversione rotazione mandrino Possibility to change electrospindle direction		NO
Rapporto di trasmissione / Gear ratio		1:1.43
Attacco utensile / Tool coupling		ER32DX - ER25 SX
Diametro codolo / Tool shank diameter	mm	2 - 20 / 2 - 16
Diametro lama / Blade diameter	mm	D = 240**
Diametro foro lama / Hole blade diameter	mm	D = 35
Peso / Weight	Kg	5
Lubrificazione / Lubrication		Grasso Grease
Temperatura max. / Max temperature	°C/F	70 / 158
Orientamento angolare / Aggregate rotation		0°/360° continuo continuous
Connessione asse C / axis connection type		H1

* vedere manuale / see user manual

** dipende dalla posizione rif.angolare / depends on pin-plate angular position

CONFIGURABILITÀ / CONFIGURABILITY

WWW-X-YYY-ZZ

ALTEZZA / HEIGHT

WWW	WWW
100	100
145	145
180	180

ATTACCO UTENSILE / TOOL HOLDER

XXX	X
ER32 - ER25	A
ER32 - PROLOCK	B

ATTACCO MANDRINO / SPINDLE INTERFACE

YYY	YYY
HSK 63F	63F
HSK 63E	63E
ISO 30	I30
ISO 30 SCM*	I3S



RIFERIMENTI / C AXIS CONNECTION

ZZ	ZZ
SCM HITECO 1 PIN	H1
SCM 3 PIN - SCM 1 PIN - MORBIDELLI 3 PIN - 1 PIN	S3/(S1)
ISO 30 SCM*	SS*
BUSELLATO	BU
BIESSE	BI
HOLZ-HER	Z1
FELDER	FE
CMS	CM
SCM 1 PIN OLD	D1
SCM 2 PIN OLD	D2
SCM/HITECO 3 PIN (con ut. pneumatiche with air supplies)	H3
SCM/MORBIDELLI 3 PIN (con ut. pneumatiche with air supplies)	SP
HOMAG (con ut. pneumatiche with air supplies)	HO

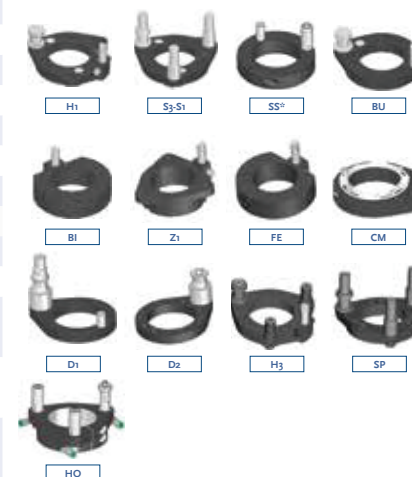

* I3S compatibile solo con SS / I3S only compatible with SS

TWIN PRO

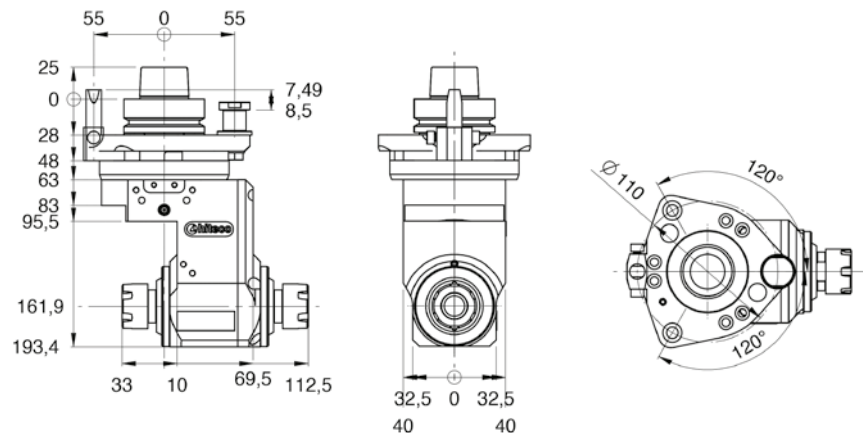

TWIN PRO ER25

Attacco mandrino / Spindle coupling		HSK 63F
Velocità max. rotazione mandrino / Max spindle speed	giri/min rpm	6800*
Velocità max. rotazione utensile / Max tool speed	giri/min rpm	18000*
Senso rotazione mandrino / Spindle rotation direction		vedi disegno see drawing
Possibilità inversione rotazione mandrino Possibility to change electrospindle direction		NO
Rapporto di trasmissione / Gear ratio		1:2.65
Attacco mandrino / Spindle coupling		HSK 63F
Attacco utensile / Tool coupling		ER25 - ER25 SX
Diametro codolo / Tool shank diameter	mm	2 - 16
Peso / Weight	Kg	5,7
Lubrificazione / Lubrication		Grasso Grease
Temperatura max. / Max temperature	°C/F	75 / 167
Orientamento angolare / Aggregate rotation		0°/360° continuo continuous
Connessione asse C / C axis connection type		H1

* vedere manuale / see user manual

CONFIGURABILITÀ / CONFIGURABILITY

WWW-X-YYY-ZZ

ALTEZZA / HEIGHT

WWW

162

162

ATTACCO UTENSILE / TOOL HOLDER

X

ER25

L

ATTACCO MANDRINO / SPINDLE INTERFACE

YYY

HSK 63F

63F

HSK 63E

63E

ISO 30

I30

ISO 30 SCM*

I3S



RIFERIMENTI / C AXIS CONNECTION

ZZ

SCM HITECO 1 PIN

H1

SCM 3 PIN - SCM 1 PIN - MORBIDELLI 3 PIN - 1 PIN

S3/(S1)

ISO 30 SCM*

SS*

BUSELLATO

BU

BIESSE

BI

HOLZ-HER

Z1

FELDER

FE

CMS

CM

SCM 1 PIN OLD

D1

SCM 2 PIN OLD

D2

SCM/HITECO 3 PIN

H3

(con ut. pneumatiche with air supplies)

SCM/MORBIDELLI 3 PIN

SP

(con ut. pneumatiche with air supplies)

HOMAG

HO

(con ut. pneumatiche with air supplies)

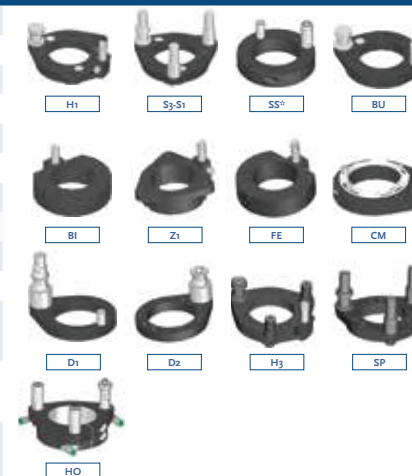

* I3S compatibile solo con SS / I3S only compatible with SS

THREE

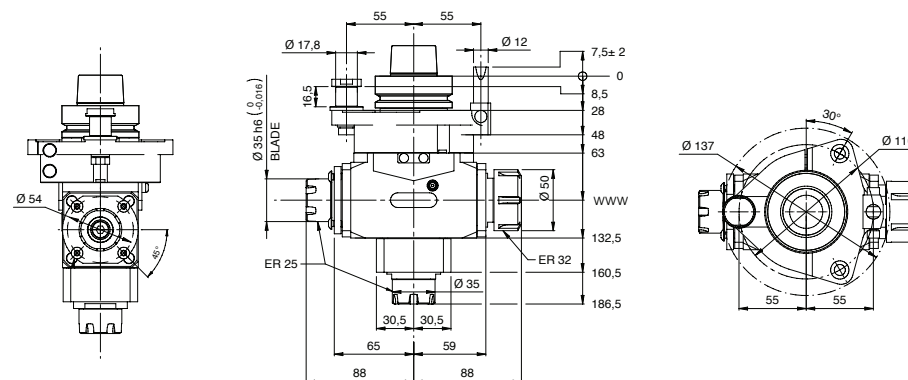

THREE ER32-ER25B

Attacco mandrino / Spindle coupling		HSK 63F
Velocità max. rotazione mandrino / Max spindle speed	giri/min rpm	10850* (ER32 - ER25B)
Velocità max. rotazione utensile / Max tool speed	giri/min rpm	15500* (ER25)
Senso rotazione mandrino / Spindle rotation direction		vedi disegno see drawing
Possibilità inversione rotazione mandrino Possibility to change electrospindle direction		NO
Rapporto di trasmissione / Gear ratio		1:1.43
Attacco utensile / Tool coupling		ER32 - 2X ER25
Diametro codolo / Tool shank diameter	mm	ER32 2-20/ER25 2-15
Diametro lama / Blade diameter	mm	D = 240**
Diametro foro lama / Hole blade diameter	mm	D = 35
Peso / Weight	Kg	5
Lubrificazione / Lubrication		Grasso Grease
Temperatura max. / Max temperature	°C/F	70 / 158
Orientamento angolare / Aggregate rotation		0°/360° continuo continuous
Connessione asse C / C axis connection type		H1

* vedere manuale / see user manual

** dipende dalla posizione rif.angolare / depends on pin-plate angular position

CONFIGURABILITÀ / CONFIGURABILITY

WWW-X-YYY-ZZ

ALTEZZA / HEIGHT

WWW

100	100
145	145
180	180

ATTACCO UTENSILE / TOOL HOLDER

X

ER32 - ER25 BLADE - ER25

Q

ATTACCO MANDRINO / SPINDLE INTERFACE

YYY

HSK 63F

63F

HSK 63E

63E

ISO 30

I30

ISO 30 SCM*

I3S



RIFERIMENTI / C AXIS CONNECTION

ZZ

SCM HITECO 1 PIN

H1

SCM 3 PIN - SCM 1 PIN - MORBIDELLI 3 PIN - 1 PIN

S3/(S1)

ISO 30 SCM*

SS*

BUSELLATO

BU

BIESSE

BI

HOLZ-HER

Z1

FELDER

FE

CMS

CM

SCM 1 PIN OLD

D1

SCM 2 PIN OLD

D2

SCM/HITECO 3 PIN

H3

(con ut. pneumatiche with air supplies)

SCM/MORBIDELLI 3 PIN

SP

(con ut. pneumatiche with air supplies)

HOMAG

HO

(con ut. pneumatiche with air supplies)

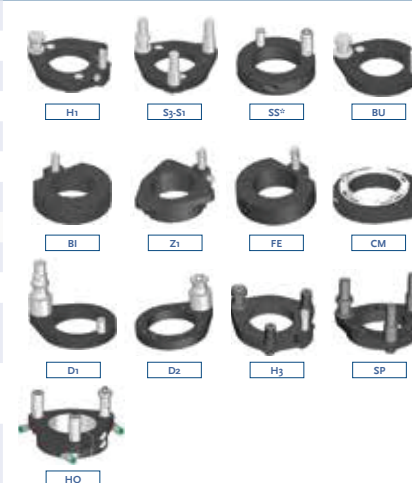

* I3S compatibile solo con SS / I3S only compatible with SS

FOUR

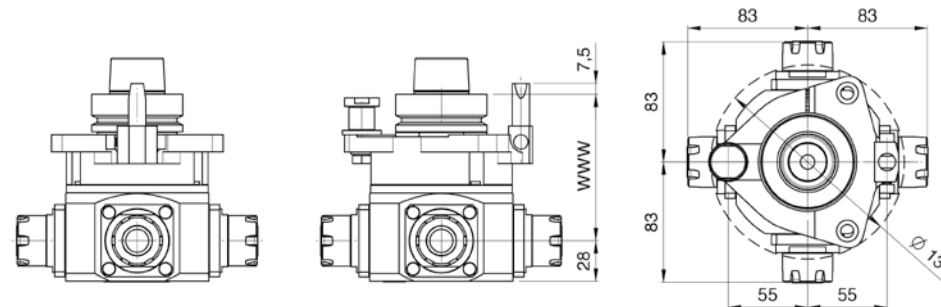

FOUR ER25

Attacco mandrino / Spindle coupling		HSK 63F
Velocità max. rotazione mandrino / Max spindle speed	giri/min rpm	10850*
Velocità max. rotazione utensile / Max tool speed	giri/min rpm	15500*
Senso rotazione mandrino / Spindle rotation direction		vedi disegno see drawing
Possibilità inversione rotazione mandrino Possibility to change electros spindle direction		NO
Rapporto di trasmissione / Gear ratio		1:1.43
Tipo pinza / Collet type		4 x ER25
Diametro lama / Blade diameter	mm	-
Diametro foro lama / Blade hole diameter	mm	-
Peso / Weight	Kg	5,6
Lubrificazione / Lubrication		Grasso Grease
Temperatura max. / Max temperature	°C/F	75 / 167
Orientamento angolare / Aggregate rotation		0°/360° continuo continuous
Connessione asse C / C axis connection type		H1

* vedere manuale / see user manual

CONFIGURABILITÀ / CONFIGURABILITY

WWW-X-YYY-ZZ	
ALTEZZA / HEIGHT	WWW
100	100
145	145
180	180
ATTACCO UTENSILE / TOOL HOLDER	X
ER25	L
ATTACCO MANDRINO / SPINDLE INTERFACE	YYY
HSK 63F	63F
HSK 63E	63E
ISO 30	I30
ISO 30 SCM*	I3S
RIFERIMENTI / C AXIS CONNECTION	ZZ
SCM HITECO 1 PIN	H1
SCM 3 PIN - SCM 1 PIN - MORBIDELLI 3 PIN - 1 PIN	S3/(S1)
ISO 30 SCM*	SS*
BUSELLATO	BU
BIESSE	BI
HOLZ-HER	Z1
FELDER	FE
CMS	CM
SCM 1 PIN OLD	D1
SCM 2 PIN OLD	D2
SCM/HITECO 3 PIN (con ut. pneumatiche with air supplies)	H3
SCM/MORBIDELLI 3 PIN (con ut. pneumatiche with air supplies)	SP
HOMAG (con ut. pneumatiche with air supplies)	HO

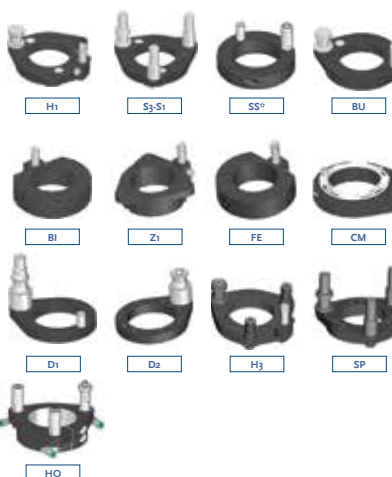

* I3S compatibile solo con SS / I3S only compatible with SS

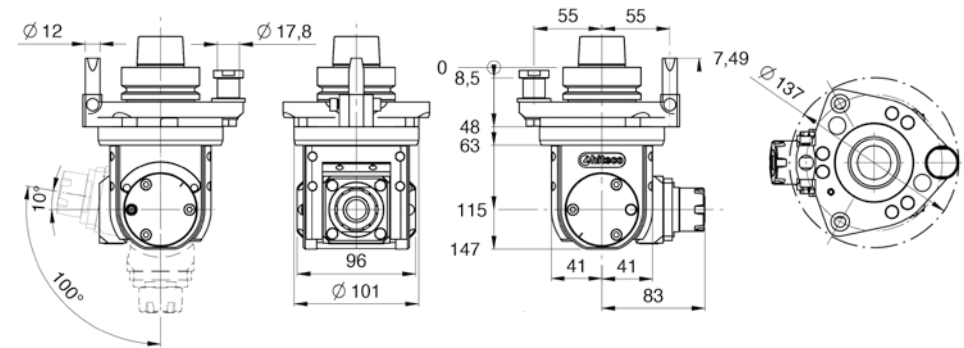

TILT ER25

Attacco mandrino / Spindle coupling		HSK 63F
Velocità max. rotazione mandrino / Max spindle speed	giri/min rpm	15500*
Velocità max. rotazione utensile / Max tool speed	giri/min rpm	15500*
Senso rotazione mandrino / Spindle rotation direction		vedi disegno see drawing
Possibilità inversione rotazione mandrino Possibility to change electrospindle direction		NO
Rapporto di trasmissione / Gear ratio		1:1
Angolo di tilt / Tilting angle		0° - 100°
Attacco utensile / Tool coupling		ER25
Diametro codolo / Tool shank diameter	mm	2 - 16
Diametro lama / Blade diameter	mm	-
Diametro foro lama / Hole blade diameter	mm	-
Peso / Weight	Kg	5
Lubrificazione / Lubrication		Grasso Grease
Temperatura max. / Max temperature	°C/F	75 / 167
Orientamento angolare / Aggregate rotation		0°/360° continuo continuous
Connessione asse C / C axis connection type		H1

* vedere manuale / see user manual

CONFIGURABILITÀ / CONFIGURABILITY

WWW-X-YYY-ZZ				
ALTEZZA / HEIGHT	WWW			
115	115			
ATTACCO UTENSILE / TOOL HOLDER	X			
ER25	L			
ATTACCO MANDRINO / SPINDLE INTERFACE	YYY			
HSK 63F	63F			
HSK 63E	63E			
ISO 30	I30			
ISO 30 SCM*	I3S			
				
	63F	63E	I30	I3S
RIFERIMENTI / C AXIS CONNECTION	ZZ			
SCM HITECO 1 PIN	H1			
SCM 3 PIN - SCM 1 PIN - MORBIDELLI 3 PIN - 1 PIN	S3/(S1)			
ISO 30 SCM*	SS*			
BUSELLATO	BU			
BIESSE	BI			
HOLZ-HER	Z1			
FELDER	FE			
CMS	CM			
SCM 1 PIN OLD	D1			
SCM 2 PIN OLD	D2			
SCM/HITECO 3 PIN (con ut. pneumatiche with air supplies)	H3			
SCM/MORBIDELLI 3 PIN (con ut. pneumatiche with air supplies)	SP			
HOMAG (con ut. pneumatiche with air supplies)	HO			
				
	H1	S3-S1	SS*	BU
				
	BI	Z1	FE	CM
				
	D1	D2	H3	SP
				
	HO			

* I3S compatibile solo con SS / I3S only compatible with SS

TILT BLADE

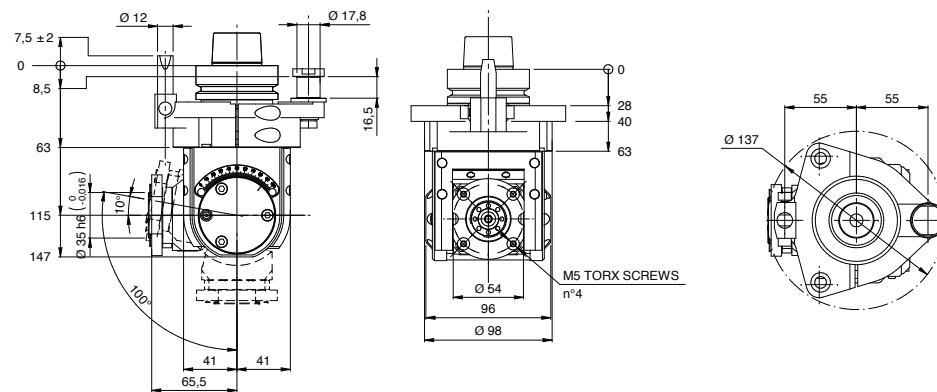

TILT ER20B

Attacco mandrino / Spindle coupling		HSK 63F
Velocità max. rotazione mandrino / Max spindle speed	giri/min rpm	15500*
Velocità max. rotazione utensile / Max tool speed	giri/min rpm	15500*
Senso rotazione mandrino / Spindle rotation direction		vedi disegno see drawing
Possibilità inversione rotazione mandrino / Possibility to change electrospindle direction		NO
Rapporto di trasmissione / Gear ratio		1:1
Angolo di tilt / Tilting angle		0° - 100°
Attacco utensile / Tool coupling		ER20B
Diametro codolo / Tool shank diameter	mm	-
Diametro lama / Blade diameter	mm	Ø 240 max
Diametro foro lama / Hole blade diameter	mm	Ø 35
Peso / Weight	Kg	5
Lubrificazione / Lubrication		Grasso Grease
Temperatura max. / Max temperature	°C/F	75 / 167
Orientamento angolare / Aggregate rotation		0°/360° continuo continuous
Connessione asse C / C axis connection type		H1

* vedere manuale / see user manual
dipende da pos. angolare e applicazione / depends on pin-plate angular pos.

CONFIGURABILITÀ / CONFIGURABILITY

WWW-X-YYY-ZZ

ALTEZZA / HEIGHT

WWW

115

115

ATTACCO UTENSILE / TOOL HOLDER

X

ER20B** + n° 4 viti torx per lama

M

ER20B** + n° 4 torx screws for blade

ATTACCO MANDRINO / SPINDLE INTERFACE

YYY

HSK 63F

63F

HSK 63E

63E

ISO 30

I30

ISO 30 SCM*

I3S



RIFERIMENTI / C AXIS CONNECTION

ZZ

SCM HITECO 1 PIN

H1

SCM 3 PIN - SCM 1 PIN - MORBIDELLI 3 PIN - 1 PIN

S3/(S1)

ISO 30 SCM*

SS*

BUSELLATO

BU

BIESSE

BI

HOLZ-HER

Z1

FELDER

FE

CMS

CM

SCM 1 PIN OLD

D1

SCM 2 PIN OLD

D2

SCM/HITECO 3 PIN

H3

(con ut. pneumatiche with air supplies)

SCM/MORBIDELLI 3 PIN

SP

(con ut. pneumatiche with air supplies)

HOMAG

HO

(con ut. pneumatiche with air supplies)

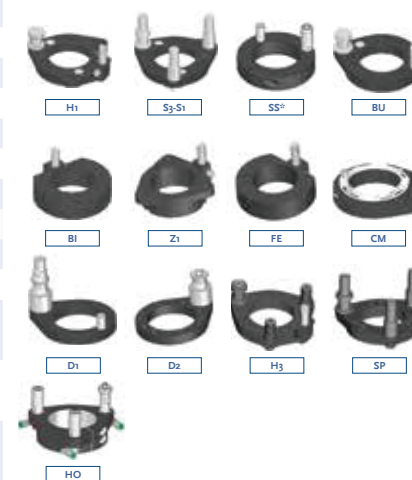

* I3S compatibile solo con SS / I3S only compatible with SS

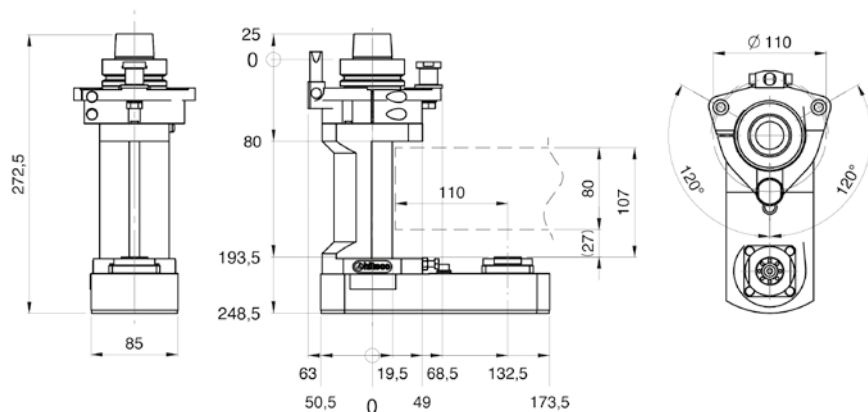

DSIDE ER20

Attacco mandrino / Spindle coupling		HSK 63F
Attacco utensile / Tool coupling		ER20
Massima velocità rotazione / Max speed	giri/min rpm	13000*
Senso rotazione mandrino / Electrospindle rotation		vedi disegno see drawing
Possibilità inversione rotazione / Possibility to change electrospindle		NO
Rapporto di trasmissione / Gear ratio		1:1
Massimo diametro punta / Max bit diameter	mm	13
Diametro lama / Blade diameter		-
Peso / Weight	kg	6
Profondità di lavorazione / Working depth		vedi disegno see drawing
Massima temperatura / Max temperature	°C/F	75
Orientamento angolare / Aggregate rotation		0°/360° continuo continuous
Connessione asse C / C axis connection type		H1

* vedere manuale / see user manual

CONFIGURABILITÀ / CONFIGURABILITY

WWW-YYY-ZZ

ALTEZZA / HEIGHT

WWW

195 195

ATTACCO UTENSILE / TOOL HOLDER

X

ER20 N

ATTACCO MANDRINO / SPINDLE INTERFACE

YYY

HSK 63F 63F
 HSK 63E 63E
 ISO 30 I30
 ISO 30 SCM* I3S



RIFERIMENTI / C AXIS CONNECTION

ZZ

SCM HITECO 1 PIN H1
 SCM 3 PIN - SCM 1 PIN - MORBIDELLI 3 PIN - 1 PIN S3/(S1)
 ISO 30 SCM* SS*
 BUSELLATO BU
 BIESSE BI
 HOLZ-HER Z1
 FELDER FE
 CMS CM
 SCM 1 PIN OLD D1
 SCM 2 PIN OLD D2
 SCM HITECO 3 PIN H3
 (con ut. pneumatiche with air supplies)
 SCM 3 PIN SP
 (con ut. pneumatiche with air supplies)
 HOMAG HO
 (con ut. pneumatiche with air supplies)

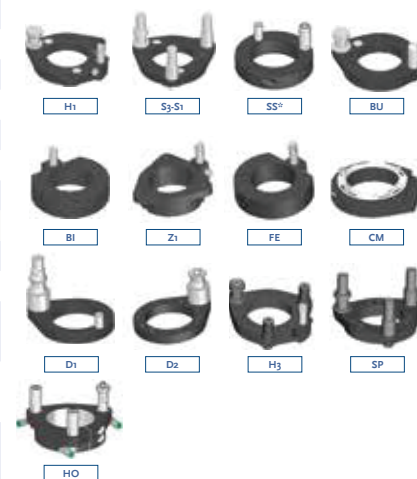

* I3S compatibile solo con SS / I3S only compatible with SS

DSIDE COMPACT

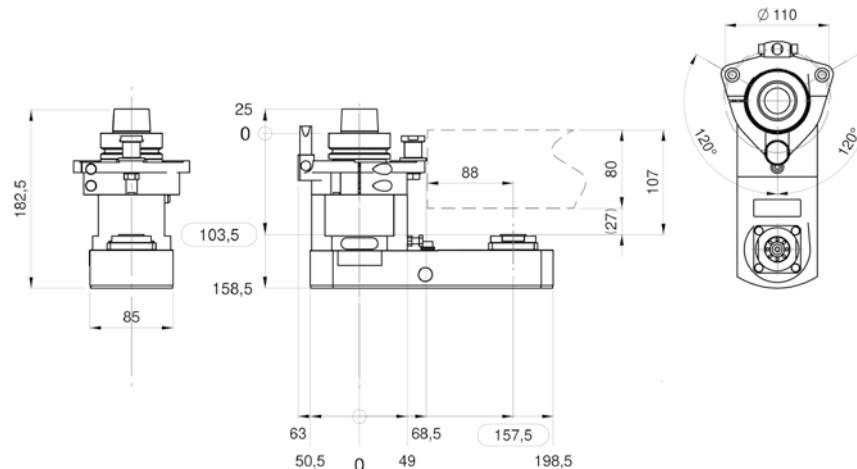

DSIDE COMPACT ER20

Attacco mandrino / Spindle coupling		HSK 63F
Attacco utensile / Tool coupling		ER20
Massima velocità rotazione / Max speed	giri/min rpm	13000*
Senso rotazione mandrino / Electrospindle rotation		vedi disegno see drawing
Possibilità inversione rotazione / Possibility to change electrospindle		NO
Rapporto di trasmissione / Gear ratio		1:1
Massimo diametro punta / Max bit diameter	mm	13
Diametro lama / Blade diameter		-
Peso / Weight	kg	6
Profondità di lavorazione / Working depth		vedi disegno see drawing
Massima temperatura / Max temperature	°C/F	75
Orientamento angolare / Aggregate rotation		0°/360° continuo continuous
Connessione asse C / C axis connection type		H1

* vedere manuale / see user manual

CONFIGURABILITÀ / CONFIGURABILITY

WWW-YYY-ZZ

ALTEZZA / HEIGHT

WWW

105 105

ATTACCO UTENSILE / TOOL HOLDER

X

ER20 N

ATTACCO MANDRINO / SPINDLE INTERFACE

YYY

HSK 63F 63F
 HSK 63E 63E
 ISO 30 I30
 ISO 30 SCM* I3S



RIFERIMENTI / C AXIS CONNECTION

ZZ

SCM HITECO 1 PIN H1
 SCM 3 PIN - SCM 1 PIN - MORBIDELLI 3 PIN - 1 PIN S3/(S1)
 ISO 30 SCM* SS*
 BUSELLATO BU
 BIESSE BI
 HOLZ-HER Z1
 FELDER FE
 CMS CM
 SCM 1 PIN OLD D1
 SCM 2 PIN OLD D2
 SCM HITECO 3 PIN H3
 (con ut. pneumatiche with air supplies)
 SCM 3 PIN SP
 (con ut. pneumatiche with air supplies)
 HOMAG HO
 (con ut. pneumatiche with air supplies)

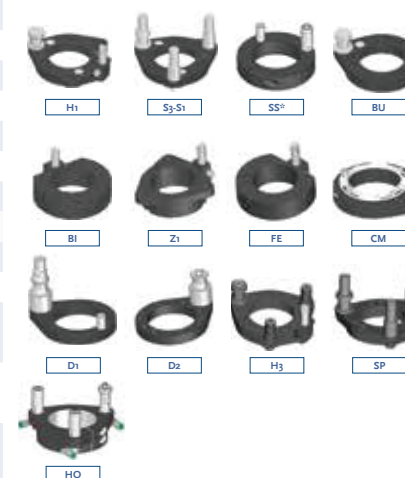

* I3S compatibile solo con SS / I3S only compatible with SS

NOTCH BLADE

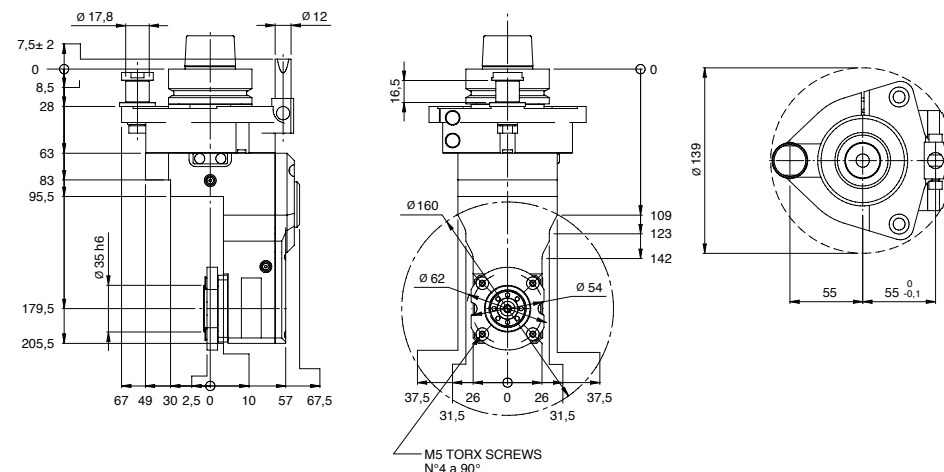

NOTCH BLADE ER20B

Attacco mandrino / Spindle coupling		HSK 63F
Velocità max. rotazione mandrino / Max spindle speed	giri/min rpm	6000*
Velocità max. rotazione utensile / Max tool speed	giri/min rpm	13000*
Senso rotazione mandrino / Spindle rotation direction		vedi disegno see drawing
Possibilità inversione rotazione mandrino / Possibility to change electros spindle direction		SI YES
Rapporto di trasmissione / Gear ratio		1:2.17
Tipo pinza / Collet type		-
Diametro lama / Blade diameter	mm	160*
Diametro foro lama / Blade hole diameter	mm	35
Peso / Weight	Kg	5
Lubrificazione / Lubrication		Grasso Grease
Temperatura max. / Max temperature	°C/F	75 / 167
Orientamento angolare / Aggregate rotation		0°/360° continuo continuous
Connessione asse C / C axis connection type		H1

* vedere manuale / see user manual

CONFIGURABILITÀ / CONFIGURABILITY

WWW-X-YYY-ZZ

ALTEZZA / HEIGHT WWW

180 180

ATTACCO UTENSILE / TOOL HOLDER X

ER20B + n° 4 viti torx per lama R
ER20B + n° 4 torx screws for blade

ATTACCO MANDRINO / SPINDLE INTERFACE YYY

HSK 63F	63F	
HSK 63E	63E	
ISO 30	I30	
ISO 30 SCM*	I3S	

RIFERIMENTI / C AXIS CONNECTION ZZ

SCM HITECO 1 PIN	H1	
SCM 3 PIN - SCM 1 PIN - MORBIDELLI 3 PIN - 1 PIN	S3/(S1)	
ISO 30 SCM*	SS*	
BUSELLATO	BU	
BIESSE	BI	
HOLZ-HER	Z1	
FELDER	FE	
CMS	CM	
SCM 1 PIN OLD	D1	
SCM 2 PIN OLD	D2	
SCM HITECO 3 PIN (con ut. pneumatiche with air supplies)	H3	
SCM 3 PIN (con ut. pneumatiche with air supplies)	SP	
HOMAG (con ut. pneumatiche with air supplies)	HO	

* I3S compatibile solo con SS / I3S only compatible with SS

MULTIBLADE

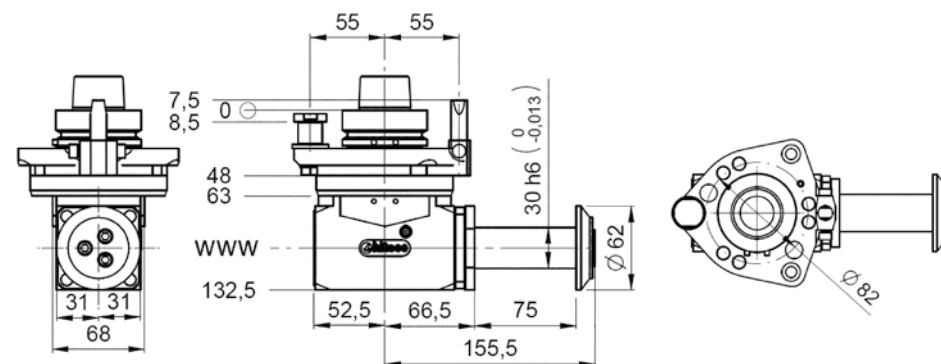

MULTIBLADE

Attacco mandrino / Spindle coupling		HSK 63F
Velocità max. rotazione mandrino / Max spindle speed	giri/min rpm	15500*
Velocità max. rotazione utensile / Max tool speed	giri/min rpm	10850*
Senso rotazione mandrino / Spindle rotation direction		vedi disegno see drawing
Possibilità inversione rotazione mandrino Possibility to change electrospindle direction		NO
Rapporto di trasmissione / Gear ratio		1:0.7
Diametro lama / Blade diameter	mm	D = 240**
Diametro foro lama / Hole blade diameter	mm	D = 30
Peso / Weight	Kg	5
Lubrificazione / Lubrication		Grasso Grease KLUEBER NBU15
Temperatura di lavoro max. / Max temperature	°C/F	75 / 167
Orientamento angolare / Aggregate rotation		0°/360° continuo continuous
Connessione asse C C / axis connection type		HIT1

* vedere manuale / see user manual

** contattare uff. tecnico / contact technical dept.

CONFIGURABILITÀ / CONFIGURABILITY

WWW-X-YYY-ZZ				
ALTEZZA / HEIGHT	WWW			
100	100			
145	145			
180	180			
ATTACCO UTENSILE / TOOL HOLDER	X			
BLADE	D			
ATTACCO MANDRINO / SPINDLE INTERFACE	YYY			
HSK 63F	63F			
HSK 63E	63E			
ISO 30	I30			
ISO 30 SCM*	I3S			
				
	63F	63E	I30	I3S
RIFERIMENTI / C AXIS CONNECTION	ZZ			
SCM HITECO 1 PIN	H1			
SCM 3 PIN - SCM 1 PIN - MORBIDELLI 3PIN - 1PIN	S3/(S1)			
ISO 30 SCM*	SS*			
BUSELLATO	BU			
BIESSE	BI			
HOLZ-HER	Z1			
FELDER	FE			
CMS	CM			
SCM 1 PIN OLD	D1			
SCM 2 PIN OLD	D2			
SCM/HITECO 3 PIN (con ut. pneumatiche with air supplies)	H3			
SCM/MORBIDELLI 3 PIN (con ut. pneumatiche with air supplies)	SP			
HOMAG (con ut. pneumatiche with air supplies)	HO			
				
	H1	S3-S1	SS*	BU
				
	BI	Z1	FE	CM
				
	D1	D2	H3	SP
				
	HO			

* I3S compatibile solo con SS / I3S only compatible with SS

VERTICAL BORE 3 OUTPUTS

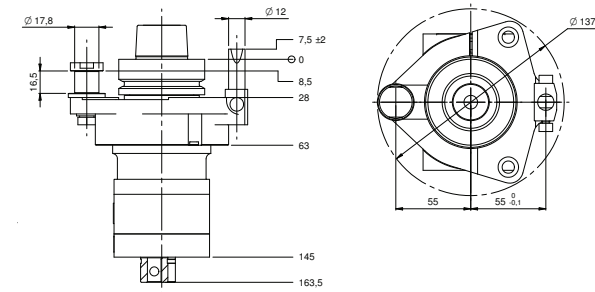

VERTICAL BORE - 3 OUTPUTS

Attacco mandrino / Spindle coupling		HSK 63F
Velocità max. rotazione mandrino / Max spindle speed	giri/min rpm	8000*
Senso rotazione mandrino / Spindle rotation direction		vedi disegno see drawing
Possibilità inversione rotazione mandrino Possibility to change electrospindle direction		SI YES
Rapporto di trasmissione / Gear ratio		1:1
Attacco punte / Tools coupling	mm	Ø10 H7 (0/+0.015)
Max diametro punte / Max bit diameter	mm	Ø10
Max lunghezza punte foratura / Max boring bits length	mm	70
Lubrificazione / Lubrication	mm	Kluber Isoflex NBU 15
Connessione asse C / C axis connection type		HITI
Orientamento angolare / Aggregate rotation		0°/360° continuo continuous
Temperatura max / Max temperature	°C/F	75 / 167
Max coppia in ingresso / Max torque input	Nm	10
Peso / Weight	Kg	4

* vedere manuale / see user manual

CONFIGURABILITÀ / CONFIGURABILITY

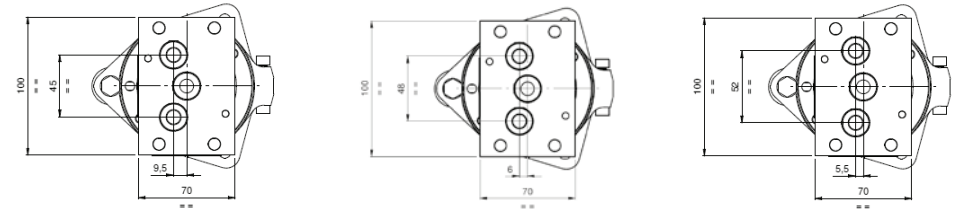

CONFIGURABILITÀ / CONFIGURABILITY

X-YYY-ZZ	
PUNTE DI FORATURA / BORDING UNITS	X
3 BITS 48/6	C48
3 BITS 45/9,5	C45
3 BITS 52/5,5	C52
ATTACCO MANDRINO / SPINDLE INTERFACE	YYY
HSK 63F	63F
HSK 63E	63E
ISO 30	I30
ISO 30 SCM*	I3S
RIFERIMENTI / C AXIS CONNECTION	ZZ
SCM HITECO 1 PIN	H1
SCM 3 PIN - SCM 1 PIN - MORBIDELLI 3 PIN - 1 PIN	S3/(S1)
ISO 30 SCM*	SS*
BUSELLATO	BU
BIESSE	BI
HOLZ-HER	Z1
FELDER	FE
CMS	CM
SCM 1 PIN OLD	D1
SCM 2 PIN OLD	D2
SCM/HITECO 3 PIN (con ut. pneumatiche with air supplies)	H3
SCM/MORBIDELLI 3 PIN (con ut. pneumatiche with air supplies)	SP
HOMAG (con ut. pneumatiche with air supplies)	HO



* I3S compatibile solo con SS / I3S only compatible with SS

VERTICAL BORE 5 OUTPUTS

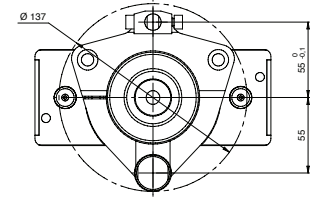
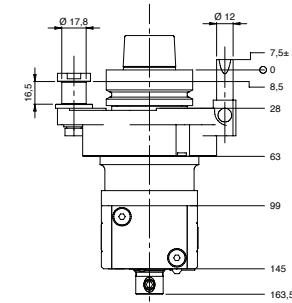
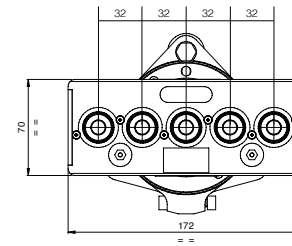

VERTICAL BORE - 5 OUTPUTS

Attacco mandrino / Spindle coupling		HSK 63F
Velocità max. rotazione mandrino / Max spindle speed	giri/min rpm	8000*
Senso rotazione mandrino / Spindle rotation direction		vedi disegno see drawing
Possibilità inversione rotazione mandrino Possibility to change electrospindle direction		SI YES
Rapporto di trasmissione Gear ratio		1:1
Attacco punte / Tools coupling	mm	Ø10 H7 (0/+0.015)
Max diametro punte / Max bit diameter	mm	Ø10
Max lunghezza punte foratura / Max boring bits length	mm	70
Lubrificazione / Lubrication	mm	Kluber Isoflex NBU 15
Connessione asse C / C axis connection type		HITI
Orientamento angolare / Aggregate rotation		0°/360° continuo continuous
Temperatura max / Max temperature	°C/F	75 / 167
Max coppia in ingresso / Max torque input	Nm	10
Peso / Weight	Kg	5

* vedere manuale / see user manual

CONFIGURABILITÀ / CONFIGURABILITY

X-YYY-ZZ

PUNTE DI FORATURA / BORDING UNITS

X

5 BITS

5P

ATTACCO MANDRINO / SPINDLE INTERFACE

YYY

HSK 63F

63F

HSK 63E

63E

ISO 30

I30

ISO 30 SCM*

I3S



RIFERIMENTI / C AXIS CONNECTION

ZZ

SCM HITECO 1 PIN

H1

SCM 3 PIN - SCM 1 PIN - MORBIDELLI 3 PIN - 1 PIN

S3/(S1)

ISO 30 SCM*

SS*

BUSELLATO

BU

BIESSE

BI

HOLZ-HER

Z1

FELDER

FE

CMS

CM

SCM 1 PIN OLD

D1

SCM 2 PIN OLD

D2

SCM/HITECO 3 PIN

H3

(con ut. pneumatiche with air supplies)

D1

D2

H3

SP

HOMAG

HO

(con ut. pneumatiche with air supplies)

HO

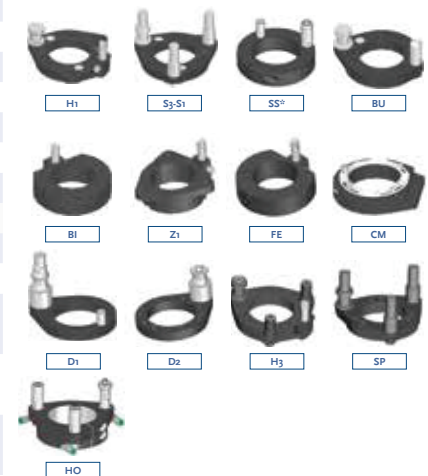

* I3S compatibile solo con SS / I3S only compatible with SS

HORIZONTAL LOW BORE

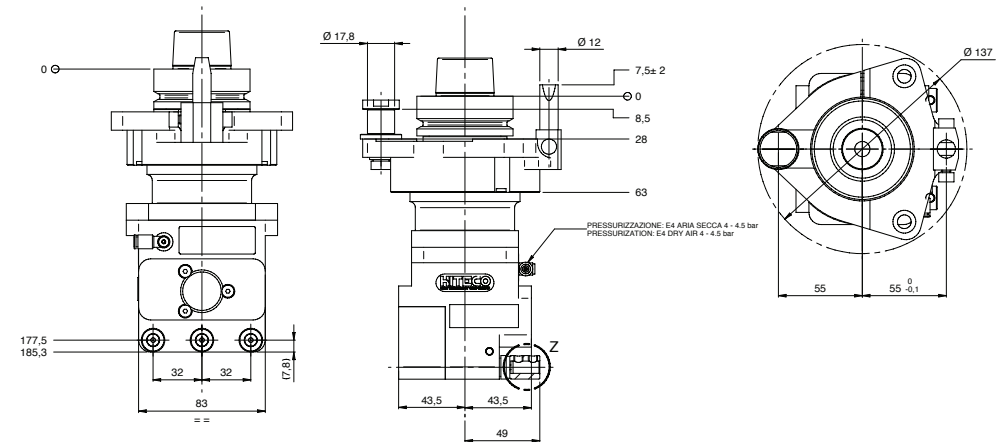

HORIZONTAL LOW BORE H178

Attacco mandrino / Spindle coupling		HSK 63F
Velocità max. rotazione mandrino / Max spindle speed	giri/min rpm	8000*
Senso rotazione mandrino / Spindle rotation direction		vedi disegno see drawing
Possibilità inversione rotazione mandrino Possibility to change electrospindle direction		SI YES
Rapporto di trasmissione / Gear ratio		1:1
Attacco punte / Tools coupling	mm	Ø8 H7 (0/+0.015)
Max lunghezza punte foratura / Max boring bits length	mm	55
Lubrificazione / Lubrication	mm	Kluber Isoflex NBU 15
Connessione asse C / C axis connection type		HITI
Orientamento angolare / Aggregate rotation		0°/360° continuo continuous
Temperatura max / Max temperature	°C/F	75 / 167
Max coppia mandrini / Max torque spindles	Nm	2
Peso / Weight	Kg	6

* vedere manuale / see user manual

CONFIGURABILITÀ / CONFIGURABILITY

YYY-ZZ

ATTACCO MANDRINO / SPINDLE INTERFACE YYY

HSK 63F	63F
HSK 63E	63E
ISO 30	I30
ISO 30 SCM*	I3S



RIFERIMENTI / C AXIS CONNECTION ZZ

SCM HITECO 1 PIN	H1
SCM 3 PIN - SCM 1 PIN - MORBIDELLI 3 PIN - 1 PIN	S3/(S1)
ISO 30 SCM*	SS*
BUSELLATO	BU
BIESSE	BI
HOLZ-HER	Z1
FELDER	FE
CMS	CM
SCM 1 PIN OLD	D1
SCM 2 PIN OLD	D2
SCM/HITECO 3 PIN (con ut. pneumatiche with air supplies)	H3
SCM/MORBIDELLI 3 PIN (con ut. pneumatiche with air supplies)	SP
HOMAG (con ut. pneumatiche with air supplies)	HO

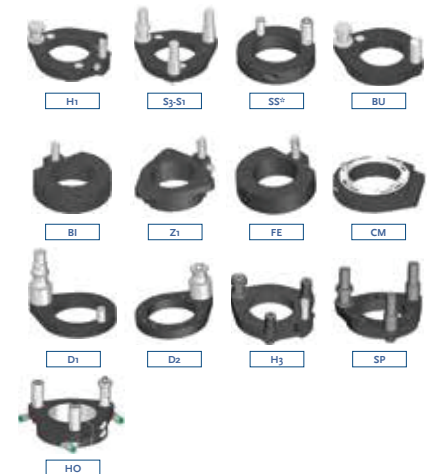

* I3S compatibile solo con SS / I3S only compatible with SS

NOTCH

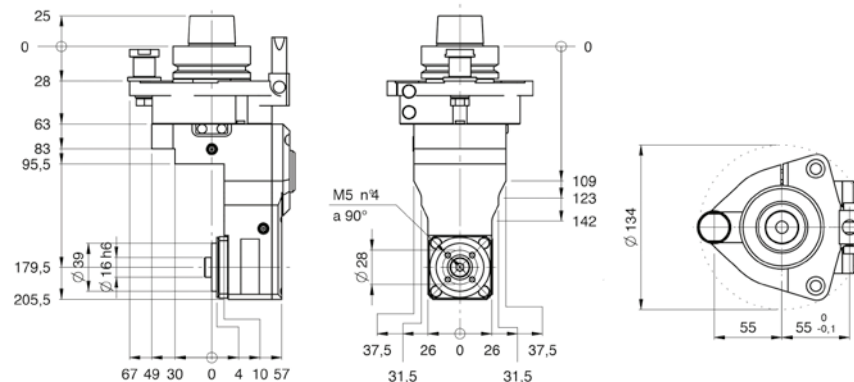

NOTCH H180

Attacco mandrino / Spindle coupling		HSK 63F
Velocità max. rotazione mandrino / Max spindle speed	giri/min rpm	6000*
Velocità max. rotazione utensile / Max tool speed	giri/min rpm	13000*
Senso rotazione mandrino / Spindle rotation direction		vedi disegno see drawing
Possibilità inversione rotazione mandrino Possibility to change electrospindle direction		NO
Rapporto di trasmissione / Gear ratio		1:2.17
Tipo pinza / Collet type		ER32
Diametro lama / Blade diameter	mm	160*
Diametro foro lama / Blade hole diameter	mm	35
Peso / Weight	Kg	5
Lubrificazione / Lubrication		Grasso Grease
Temperatura max. / Max temperature	°C/F	75 / 167
Orientamento angolare / Aggregate rotation		0°/360° continuo continuous
Connessione asse C / C axis connection type		H1

* vedere manuale / see user manual

CONFIGURABILITÀ / CONFIGURABILITY

WWW-X-YYY-ZZ

ALTEZZA / HEIGHT

WWW

180 180

ATTACCO UTENSILE / TOOL HOLDER

X

FRESA CUTTER

P

ATTACCO MANDRINO / SPINDLE INTERFACE

YYY

HSK 63F	63F
HSK 63E	63E
ISO 30	I30
ISO 30 SCM*	I3S



RIFERIMENTI / C AXIS CONNECTION

ZZ

SCM HITECO 1 PIN	H1
SCM 3 PIN - SCM 1 PIN - MORBIDELLI 3 PIN - 1 PIN	S3/(S1)
ISO 30 SCM*	SS*
BUSELLATO	BU
BIESSE	BI
HOLZ-HER	Z1
FELDER	FE
CMS	CM
SCM 1 PIN OLD	D1
SCM 2 PIN OLD	D2
SCM HITECO 3 PIN (con ut. pneumatiche with air supplies)	H3
SCM 3 PIN (con ut. pneumatiche with air supplies)	SP
HOMAG (con ut. pneumatiche with air supplies)	HO

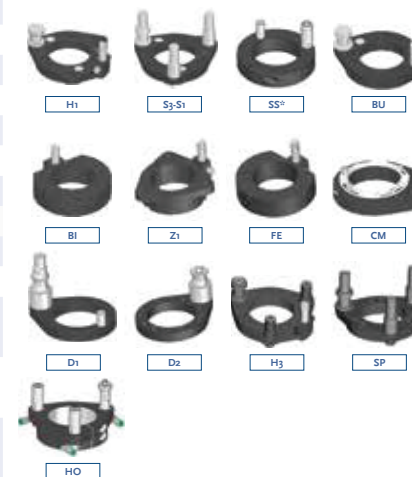

* I3S compatibile solo con SS / I3S only compatible with SS

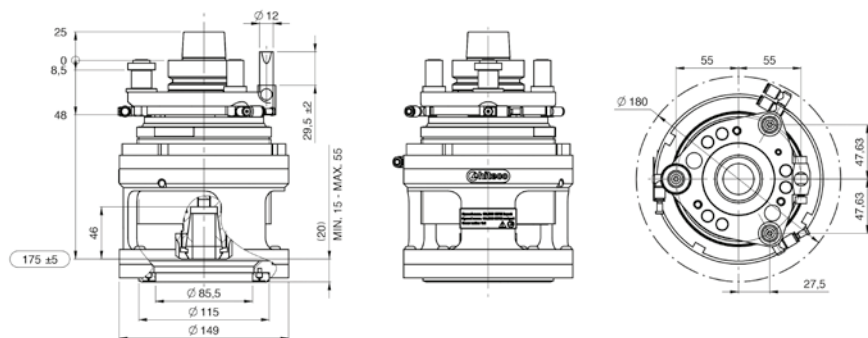

COPY ER32 H175

Attacco mandrino / Spindle coupling		HSK 63F
Velocità max. rotazione mandrino / Max spindle speed	giri/min rpm	18000*
Senso rotazione mandrino / Spindle rotation direction		vedi disegno see drawing
Possibilità inversione rotazione mandrino Possibility to change electrospindle direction		NO
Rapporto di trasmissione / Gear ratio		1:1
Attacco utensile / Tool coupling		ER32
Diametro codolo / Tool shank diameter	mm	2 - 20
Capacità palpante / Floating Capacity	mm	6.5
Peso / Weight	Kg	7
Lubrificazione / Lubrication		Grasso Grease
Temperatura max. / Max temperature	°C/F	75 / 167
Connessione asse C / C axis connection type		H3

* vedere manuale / see user manual

CONFIGURABILITÀ / CONFIGURABILITY

WWW-X-YYY-ZZ

ALTEZZA / HEIGHT

WWW

175 175

ATTACCO UTENSILE / TOOL HOLDER

X

ER 32 C

ATTACCO MANDRINO / SPINDLE INTERFACE

YYY

HSK 63F	63F
HSK 63E	63E
ISO 30	I30



RIFERIMENTI / C AXIS CONNECTION

ZZ

SCM/HITECO 3 PIN
(con ut. pneumatiche with air supplies) H3

SCM/MORBIDELLI 3 PIN
(con ut. pneumatiche with air supplies) SP

HOMAG
(con ut. pneumatiche with air supplies) HO

BIESSE
(con ut. pneumatiche with air supplies) BP

BUSELLATO BU

FELDER FE



VARIE / SUNDRY ITEMS

FLANGIA PALPATRICE FLOATING FLANGE D40
Dutensile TOOL Dmax max: 40mm

FLANGIA PALPATRICE FLOATING FLANGE D116
Dutensile TOOL Dmax max: 40mm

ANELLO DI SPESSORAMENTO SPACER RING AS

* I3S compatibile solo con SS / I3S only compatible with SS

VERTICAL BORE 3/4 OUTPUTS



VERTICAL BORE

Attacco mandrino / Spindle coupling	giunto monodente single tooth joint	
Velocità max. rotazione mandrino / Max spindle speed	giri/min rpm	3000
Velocità rotazione utensile / Tool speed	giri/min rpm	4200
Senso rotazione mandrino / Spindle rotation direction	vedi disegno see drawing	
Possibilità inversione rotazione mandrino Possibility to change electros spindle direction	SI YES	
Rapporto di trasmissione / Gear ratio	1:1.4	
Numero mandrini / Spindles	3	4
Interasse / Centre to centre distance	vedi disegno see drawing	
Diametro codolo / Tool shank diameter	mm	ø 7H7
Peso / Weight	kg	2.5
Lubrificazione / Lubrication	Grasso Grease	
Temperatura di lavoro / Working temperature	°C/F	75 / 167
Connessione asse C / C axis connection type	-	
Orientamento angolare / Aggregate rotation	-	

* vedere manuale / see user manual

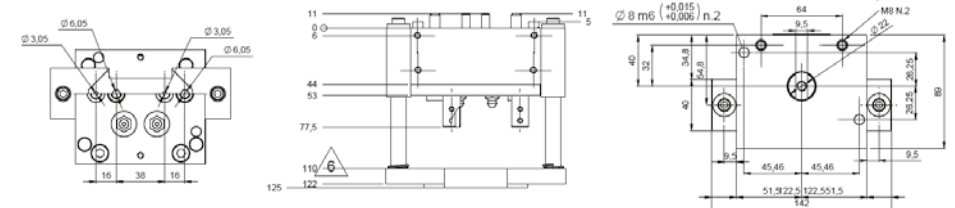
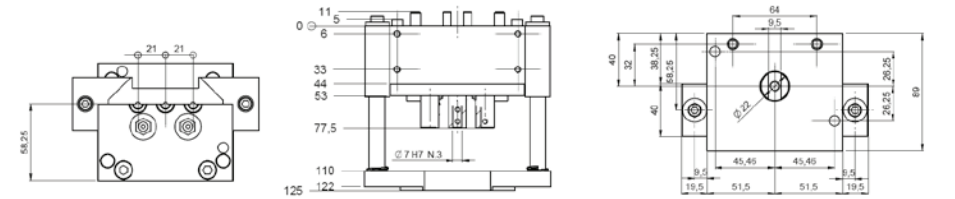
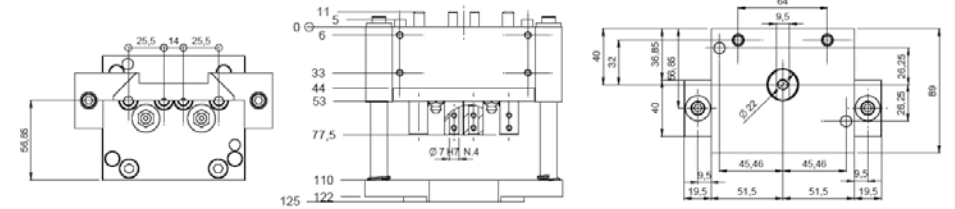

VERTICAL BORE 6 OUTPUTS

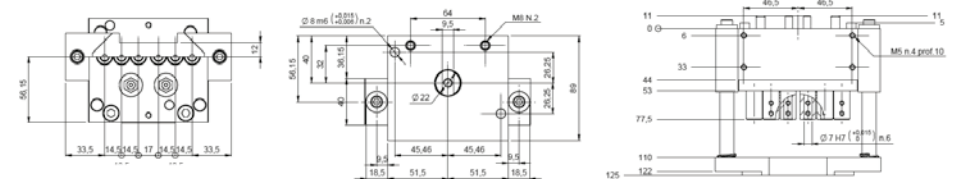
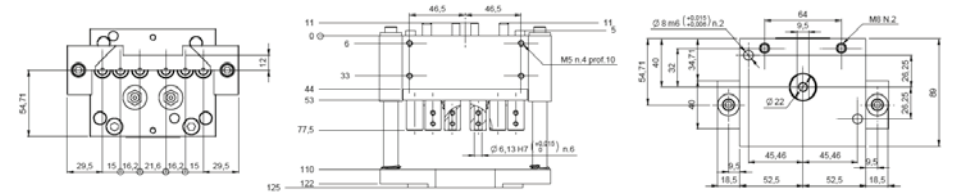
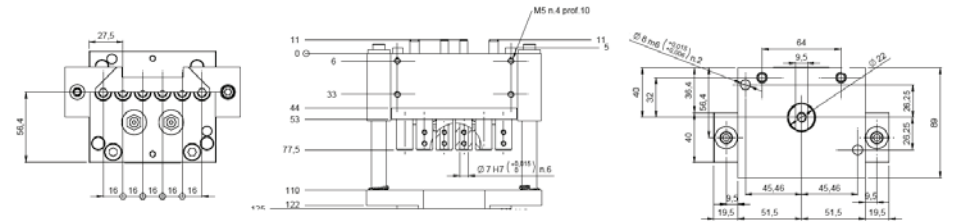

VERTICAL BORE

Attacco mandrino / Spindle coupling	giunto monodente single tooth joint	
Velocità rotazione mandrino / Spindle speed	giri/min rpm	3000
Velocità rotazione utensile / Tool speed	giri/min rpm	4200
Senso rotazione mandrino / Spindle rotation direction	vedi disegno see drawing	
Possibilità inversione rotazione mandrino Possibility to change electros spindle direction	SI YES	
Rapporto di trasmissione / Gear ratio	1:1.4	
Numero mandrini / Spindles	6	
Interasse / Centre to centre distance	vedi disegno see drawing	
Diametro codolo / Tool shank diameter	mm	ø 7H7
Peso / Weight	kg	2.5
Lubrificazione / Lubrication	Grasso Grease	
Temperatura di lavoro / Working temperature	°C/F	75 / 167
Connessione asse C / C axis connection type	-	
Orientamento angolare / Aggregate rotation	-	

* vedere manuale / see user manual

NOTE / NOTES



ss 258 Marecchia, 34 47826 Villa Verucchio, Rimini - Italia
tel. +39.0541.674940 - fax +39.0541.674962
www.hiteco.net