

Processing Centres B600/700



Be on the safe side with HOMAG

An investment in a new machine or plant should not be an experiment. Opt for a competent, experienced and reliable partner you can trust – opt for HOMAG.

- Competence and experience gathered over almost 50 years
- Production of over 1,000 processing centres a year throughout the HOMAG Group
- A motivated workforce of over 4,000 working to produce the legendary standard of HOMAG quality in 12 locations

B600/700 gantry series processing centres offer an extensive range of equipment possibilities for industrial multiple-shift operation. Different process technologies such as sawing, trimming, edge banding, hardware mounting, measurement processes and 3D processing can all be combined to ensure a truly future-proof investment.





Finish processing of furniture component edges



Simultaneous processing of a door frame and door leaf



Contents

| | |
|----|------------------------------------|
| 06 | B600/700 – the complete system |
| 10 | Furniture production |
| 12 | Staircase production |
| 14 | Door production |
| 16 | Window production |
| 18 | Home and vehicle interior fittings |
| 20 | Nesting |
| 22 | Console tables |
| 24 | Automatic positioning tables |
| 26 | Matrix tables |
| 30 | Processing units |
| 34 | Automatic workpiece handling |
| 36 | Software/control |
| 38 | LifeCycle cost |
| 40 | Technical data B600/700 |

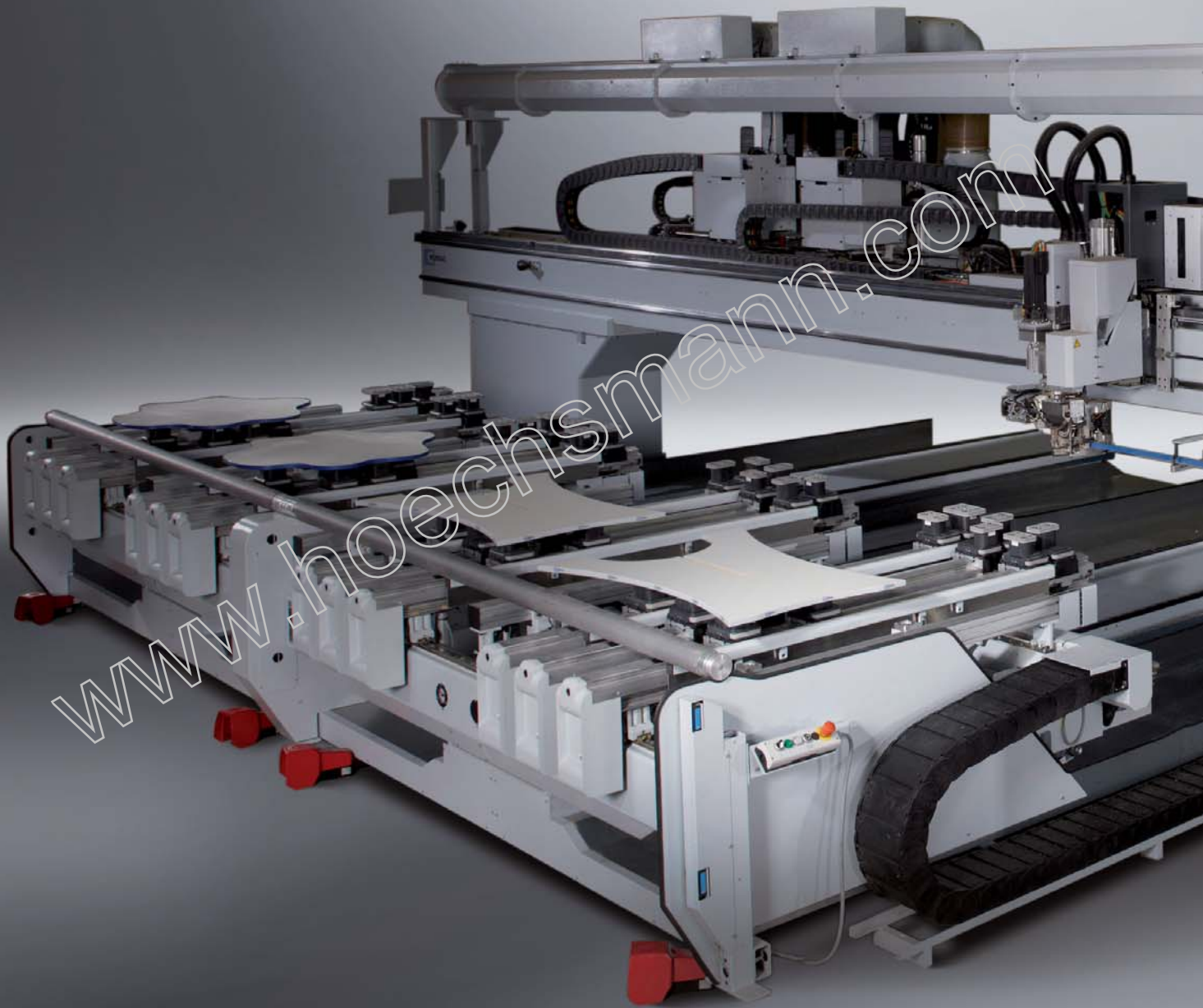

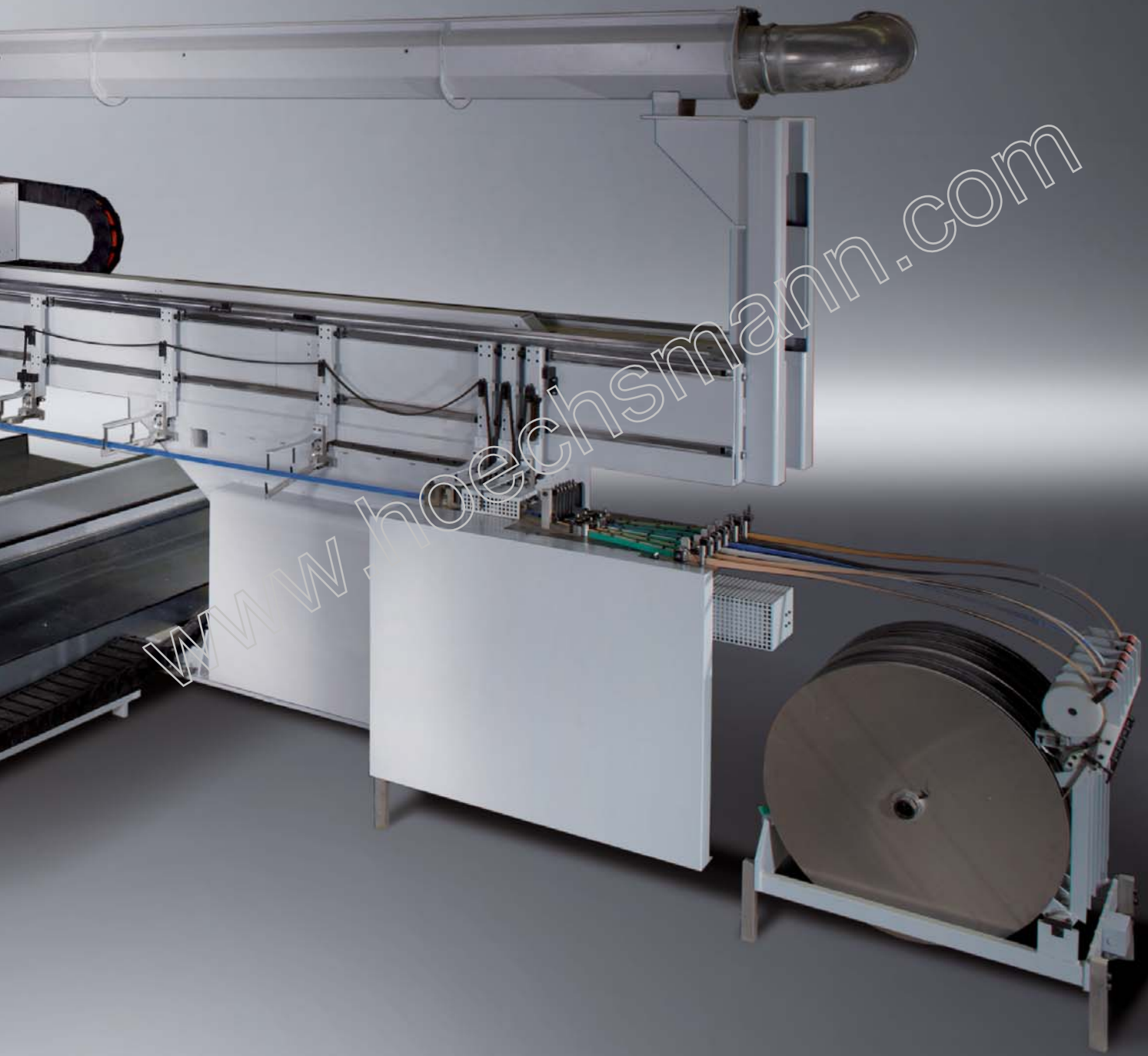

Data link

CAD/CAM

Data transfer from CAD/CAM systems for fast program generation

ERP systems

Direct link to ERP systems for the transmission of job lists

LifeCycle cost

TeleServiceNet

Teleservice round the clock to reduce standstill times and prevent costly service callouts

Inspection and maintenance

Preventive machine checks and exchange of wearing parts to prevent machine failure

Modifications

Increased machine life cycle due to capacity for retrofitting units, clamps or automatic workpiece handling for adjustment to new products

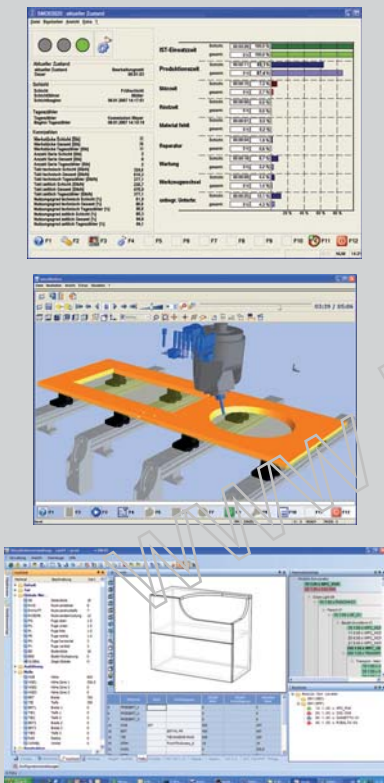

Process optimization

Monitoring

Feedback of machine and order status using MDA (machine data acquisition)

Simulation

Program sequence testing for precise production time determination and production planning, including machine component and clamp collision analyses

Automation

Part handling

Linear gantries for automatic part handling integrated into the processing centre's control system with no interfaces and without additional programming

Alternatively robot systems from LIGMATECH which are capable of executing additional functions such as part identification, sorting and so on

Scaleable output

Up to four processing units can be deployed simultaneously or independently in sets of two – depending on your own specific performance requirements



Energy efficiency

Cost reduction by optimizing energy consumption through:

- The use of a water ring vacuum pump for spindle cooling
- Intelligent standby operation
- Efficient dust extraction flap control in conjunction with two separate Z axes per processing unit



www.hoechsmann.com

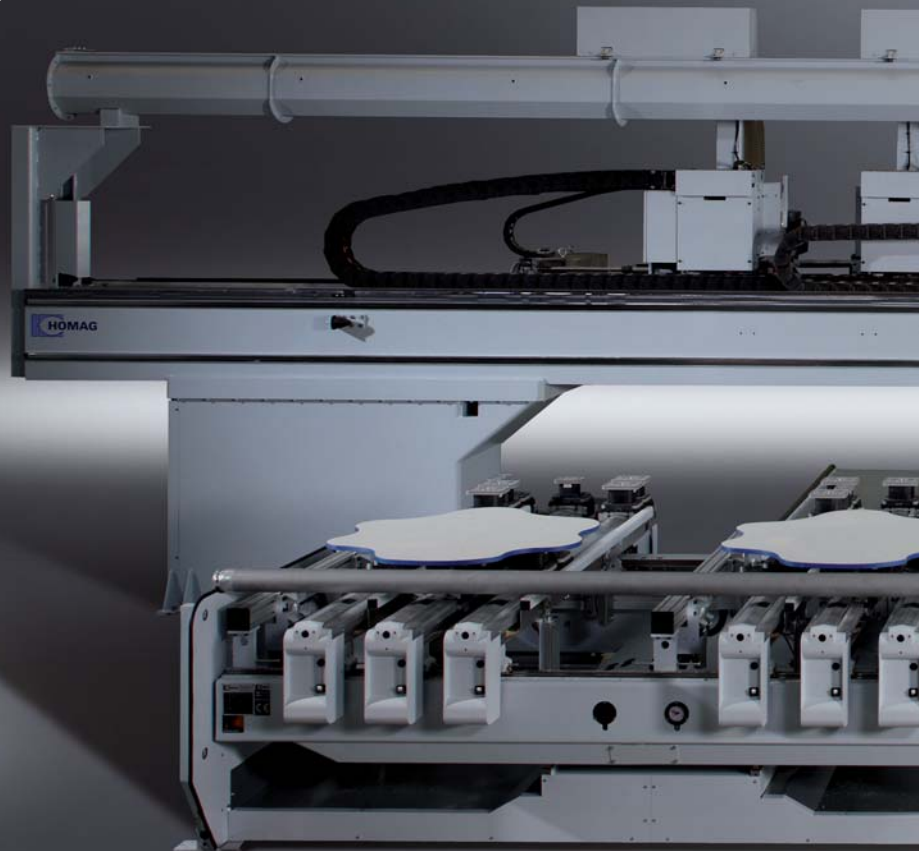

Complete systems direct from the factory

Deciding in favour of a HOMAG machine means investing in a highly efficient processing centre with the capability to fulfil wide-ranging different manufacturing requirements. Because each machine is designed to permit need-driven upgrading and adaptation to cover additional processing functions. Seen from this angle, the processing centre provides a complete system guaranteeing maximum performance and efficiency for even the most individual of production requirements.



Different table systems for flexible, reliable fixture of different workpieces. Depending on the workpiece geometry and surface properties of the workpieces, fixture can take place by means of vacuum, pneumatic or mechanic clamps.

Process integration

Integrating several work processes into one eliminates handling costs and transportation damage as well as enhancing precision. All in a single work step:

- Drilling, trimming, sawing
- High-precision electronically traced processing operations
- Hardware mounting
- 5-axis shaped component processing
- Edge banding

Workpiece fixture

Consol tables

The consol table is the flexible solution offering optimum waste piece and chip disposal

Automatic positioning console table (AP table)

The AP table is our high-end system for production cells and batch size one (B700)

Matrix table

The matrix table is the classical variant for nesting, when processing small parts or using templates

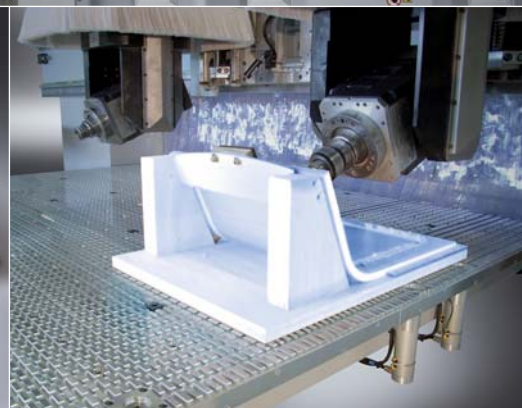
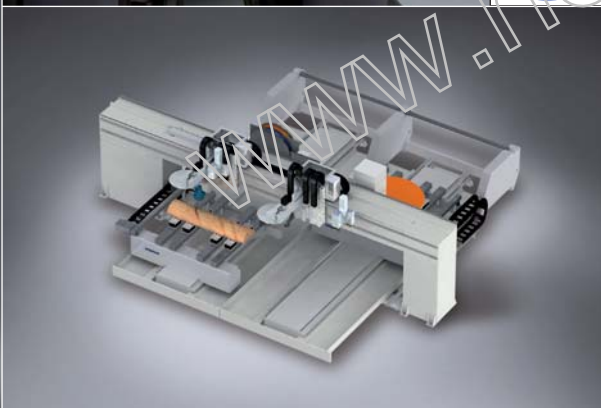
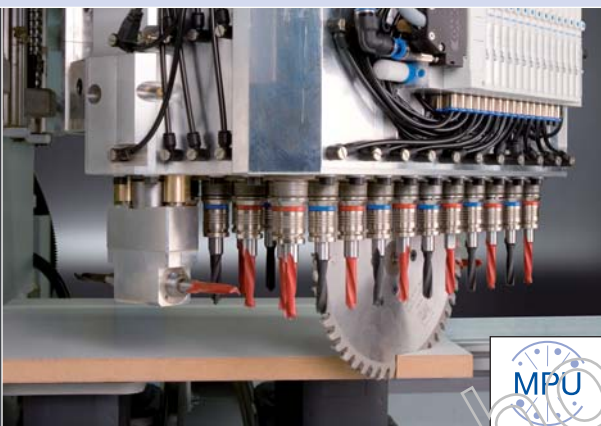

Processing dimensions

Single part processing

Coupling both tables allows extremely large-area workpieces of up to 3,700/3,700 mm (B600) or 6,200/2,550 mm (B700) to be processed

Alternating processing

Two tables with a maximum dimension of 2,100/3,770 mm (B600) or 3,050/2,550 (B700) allow resetting and loading processes to be performed simultaneously with processing operations

Block processing

Cubic workpieces of up to 500 mm in height (B700) can be completely processed by the large 600 or 950 mm Z axes, even when working with the maximum workpiece length of 230 mm (measured from the HSK support)

Furniture production

Flexibility is paramount to the economical production of furniture components. HOMAG machines are capable of performing several different furniture component processing operations including edging, and are also able to cope with wide-ranging workpiece geometries and quantities.

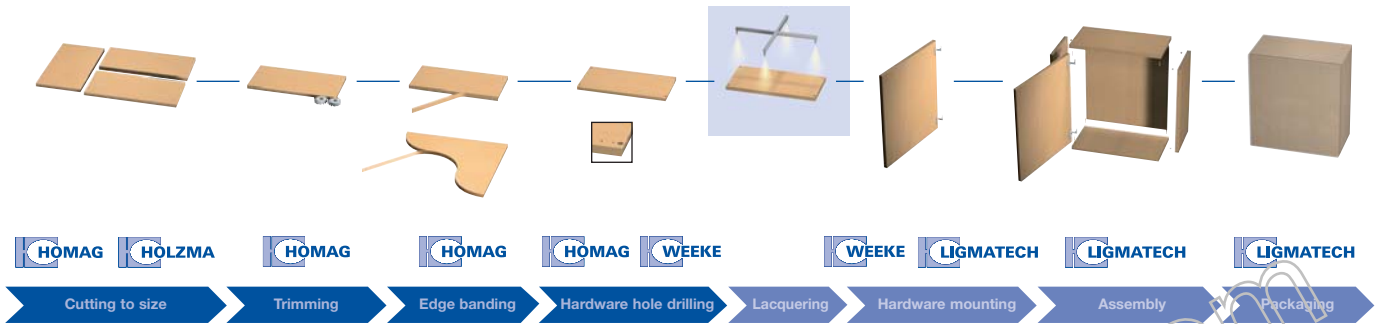

Series 600 and 700 processing centres provide the assurance of outstanding quality and efficiency improvements through:

- Integration of different work steps such as sizing, edging and drilling
- Automatic part handling
- Optimized process parameters per workpiece (feed rates, rotational speeds, tools etc.)
- Flexible adjustment of your products to market demand "without" machine restrictions



sensoFlex tracing system

- Perfect workpiece quality – the traced spindle compensates any unevenness and unwanted tolerances
- Complete flexibility through the use of tracing for different tools
- Functional upgrade through the use of wide-ranging different units (the tracing ring automatically travels upwards)
- Sensitive tracing pressure adjustment facility for sensitive materials

Drilling units

- Different drilling heads with variable speeds of up to 7,500 rpm and patented quick-change system for drill bit changeover without the use of tools
- The Multi Processing Unit (MPU) is capable of stepless 360° swivel action, allowing both the saw and all 20 vertical and 10 horizontal spindles to be deployed at any optional angle
- A trimming spindle attachment saves tool changes and enhances productivity

Edge banding (B700)

- Different edge banding units such as the **powerEdge** gluing unit offer complete processing in a single step
- Different gluing units can be used with the utmost flexibility, e.g. for softforming, T-section edging material or edge**Folding**

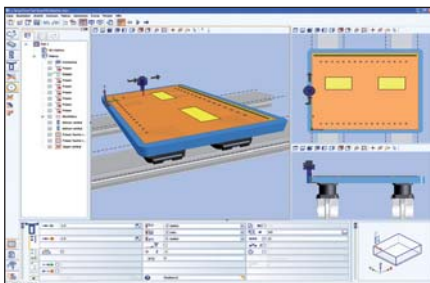
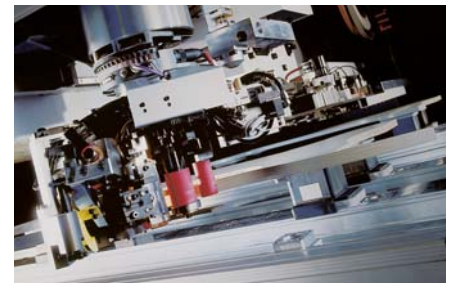
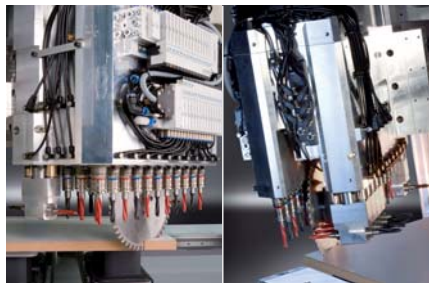

woodWOP

woodWOP is the HOMAG Group's CNC programming system. The modern user interface centres on the large graphic area used for displaying workpieces in 3D. Trimming and drilling operations or sawing cuts are quickly and simply programmed by entering the processing parameters and realistically displayed by the graphics – guaranteeing maximum programming reliability and continuous control during program generation

TBP – gantry feeder

- Reduced handling costs
- Release of manpower
- Increased machine running times (machine continues producing during operator break times)
- Machine-integrated control system

Console tables

- Console tables offer optimum facility for waste piece disposal
- Automatic console and clamp positioning (AP table) provides the ideal addition for automatic feed / small batch sizes

Staircase production

Free design and automatic production of every conceivable type of staircase. HOMAG processing centres with 5-axis technology make for a drastic reduction of production times. Technically speaking, they offer practically unlimited scope.

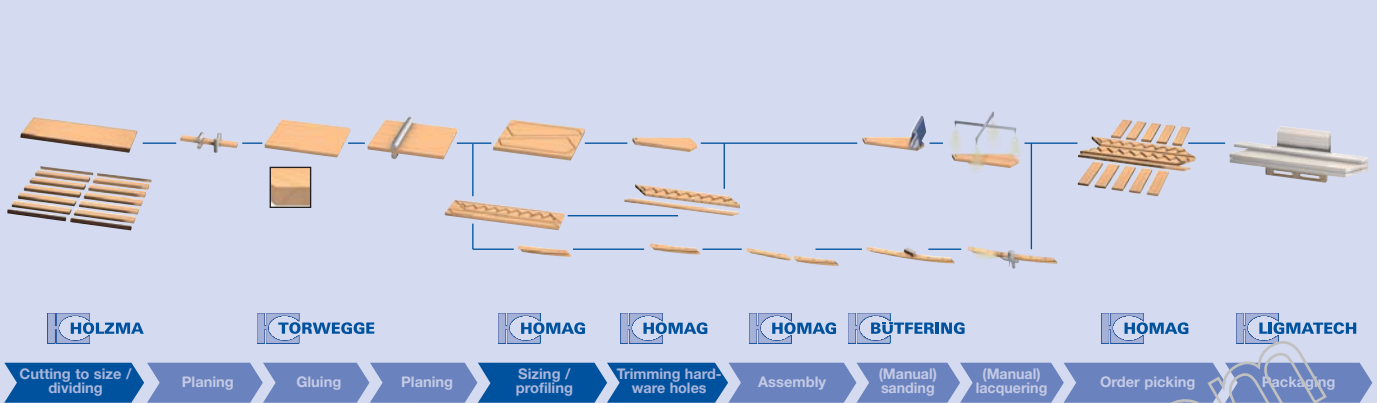

Processing centres with 5-axis and 4-axis spindles for simultaneous processing of curved elements for hand rails and staircase treads

Your processing centre can be configured to be as individual as the solid wood types you process. Depending on your production sequence, we offer ideal solutions for:

- Staircase tread production including dividing the gluelam panels using the nesting process
- Profiling curved handrail elements using 5-axis technology
- Staircase stringer production complete with all the necessary recesses and trimming operations, even with complex geometries
- Automatic workpiece handling
- Adoption of data from all trade-specific software packages



5-axis technology

- Trimming spindles with up to 5 axes and in different performance categories offer high hogging output and outstanding processing results

Patented pneumatic interface

- The patented pneumatic interface permits the deployment of traced units for processes such as precise staircase tread rounding independently of thickness tolerances
- Spindle performance is simultaneously increased by means of an additional cooling unit

Console tables

- Console tables with integrated vacuum and additional pneumatic systems provide optimum waste piece and chip disposal in conjunction with flexible, secure workpiece fixture

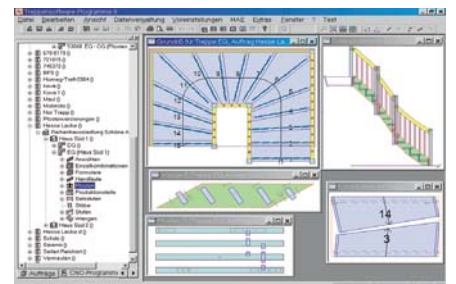

Automatic positioning console tables

- The AP table for automatic positioning of clamping elements offers scope for traversing workpieces, for instance after the separation of two staircase treads, for further processing operations

Independent processing

- Simultaneous processing of staircase treads using a traced unit and a curved handrail element using a 5-axis trimming spindle (background)

Staircase software

- Data links to all commonly used trade-specific software packages permit fast, automatic provision of machine programs

Door production

From the standard door to the custom-produced design, from series manufacture through to bespoke batch one production: Our machines and plants are designed to address widely differing requirements and adjust quickly and efficiently to the demands of each application.

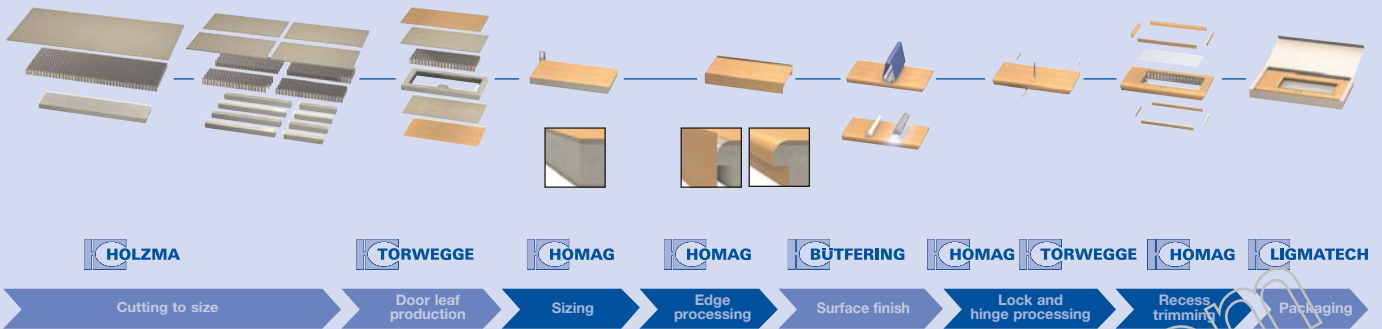

Production cell inclusive of flip station, door leaf identification by means of transponder and automatic workpiece cleaning

No matter how complex the door leaf structure or rebate geometry of your top-quality door elements are: HOMAG offers processing centres with up to four processing units for simultaneous processing – for example of two different door leaves. All processing steps are performed to a high degree of precision:

- Profiling and grooving, for example for door seals
- Trimming for glazing panels
- Lock and hinge processing operations
- Decorative grooves with precise surface tracing
- Frame connecting hole trimming and drilling operations
- Edging door leaf rebates



Independent processing

- Using several processing units with up to 5 axes each, almost any conceivable processing operation can be performed at high output / low piece costs



Position measurement

- Automatic position measurement, for example of door leaves, is carried out to ensure optimum processing precision



High spindle output

- Trimming spindles with an output of up to 28 kW offer sufficient reserves – even for double rebates on functional doors. This takes care of high feed rates even when processing hard woods



Edge banding

- Automatic batch size 1 edging of flush doors and doors with single and double rebates is performed in conjunction with edge banding units



Frame clamping elements

- Special clamping elements permit the secure clamping of surround frames with different jamb depths and architrave widths
- Block frames are processed on 5 sides without manual intervention in conjunction with the automatic positioning AP table, while automatic reclamping is made possible by the highly rigid powerClamp system

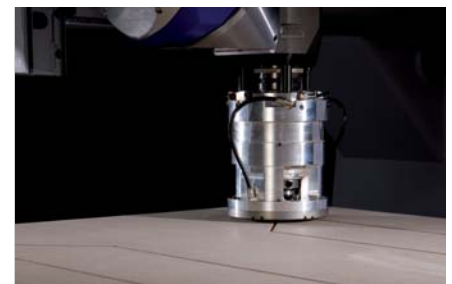

Decorative grooves

- Traced units permit the precise trimming of decorative grooves or rounding of door leaves while compensating for workpiece tolerances

Window production

It is impossible nowadays to imagine window production without the benefits of modern CNC processing. As the market leader, HOMAG offers highly efficient complete solutions which allow up to five different work steps to be performed on a single processing centre.

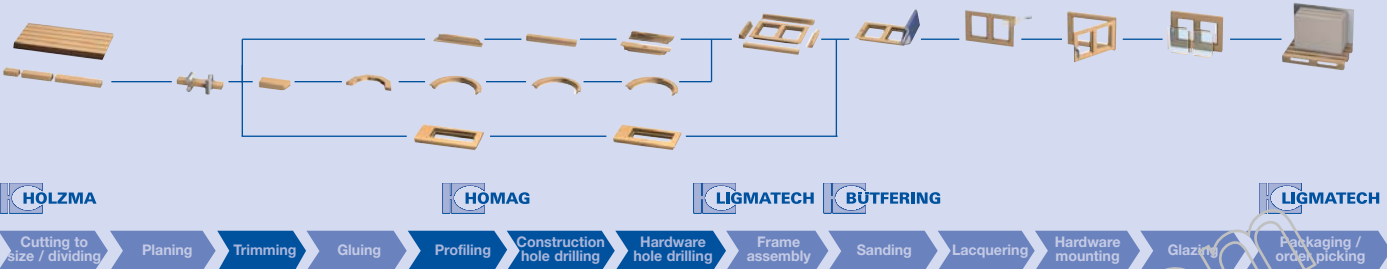

powerProfiler for window processing

Ever more stringent energy saving, noise insulation and safety requirements have culminated in a wide variety of different window systems. HOMAG offers a selection of highly flexible processing centres designed to address the demands of present and also future window design characteristics, such as:

- Greater profile depths of up to 150 mm for greater thermal insulating glass thicknesses and improved insulation performance
- Different materials such as insulating core panels in PU and linings made of purenit or aluminium
- Conservatory and facade constructions in multiplex or other materials
- Increasing integration of functional assemblies such as ventilators, alarm system contacts etc.

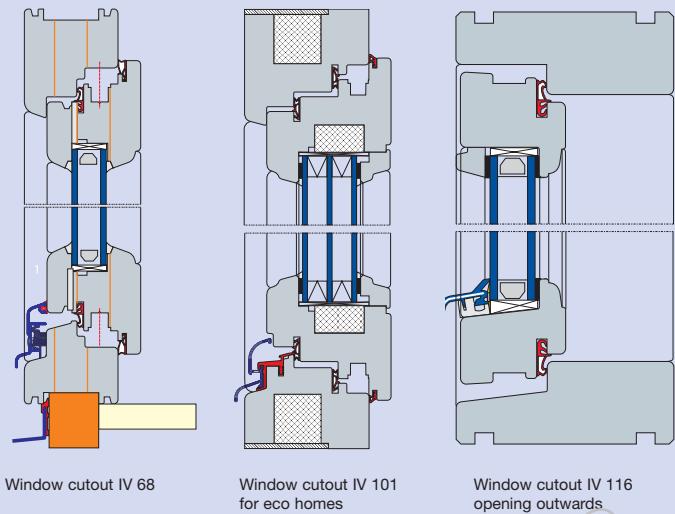

5-axis technology

- For processing upright / transom constructions in conservatories and facade construction, a 5-axis spindle is used for shift cuts and hardware hole trimming operations



Independent operation

- High output of up to 400 window units per shift through the simultaneous deployment of 2 trimming spindles and one cutting station
- 5-sided complete processing by automatic reclamping



High spindle output

- Trimming spindles with up to 28 kW output guarantee high feed rates coupled with high hogging cross-sections

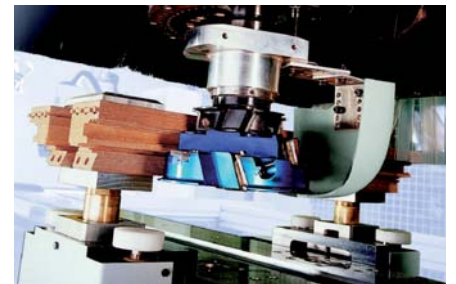

Front door leaf processing

- Complete processing of both single window components and door leaves is possible on one processing centre

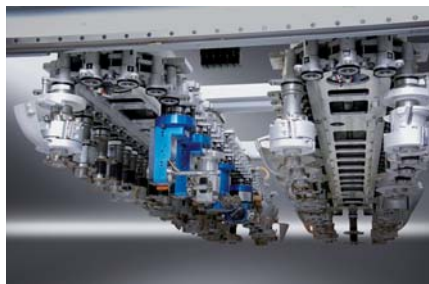

Tool change systems

- Large tool storage systems providing up to 432 slots permit the production of wide-ranging different window systems with profile depths of up to 120 mm without the need for manual tool changes



Arched components

- Additional transverse consoles permit the processing of arched components

Home and vehicle interior fittings

Individual production and precise processing of wide-ranging different materials are essential when it comes to the efficient processing of interior fittings. Not only does 5-axis technology permit a large variety of processing operations without additional units, it also opens up scope for creative product design, including features such as curved panelling.



BOF 611 with automatic feeding and stacking

Top-quality interior fittings are characterized by individual design and an extensive choice of different materials. The resulting demands made on processing centres, such as 5-axis technology for curved fronts or trimming tool cooling systems for acrylic processing are all provided by HOMAG processing centres – effectively removing future barriers to:

- the use of wide-ranging different materials
- creative design of interior fittings for your customers
- precision fitting and reproduction accuracy even for the most complex shapes
- surface designs on materials such as engraving effects, acoustic grooves or boreholes
- fast, reliable programming and production by adopting CAD/CAM data



Minimum quantity lubrication for aluminium

The patented unit interface with facility for pneumatic and fluid transmission to exchangeable units allows cooling and lubrication as well as the reliable removal of chips

Five-axis technology

The DRIVE5+ five-axis spindle offers whole new scope for design, and a wide range of available future-proofing options for the ultimate investment security. Where higher output requirements exist, also available as a double pack

High-gloss trimming

Using variable spindle speeds of 100 – 24,000 rpm in conjunction with monocrystalline diamond cutters and the highly rigid machine construction, high-gloss trimming operations on acrylic are possible achieving a remarkable standard of quality

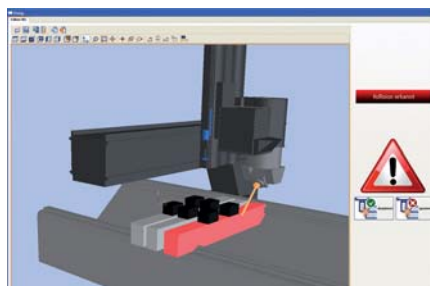
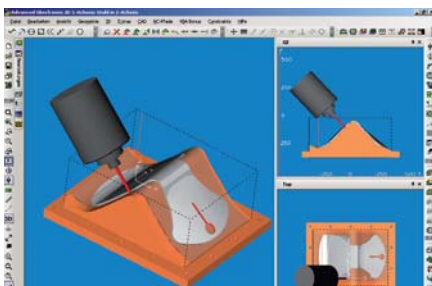
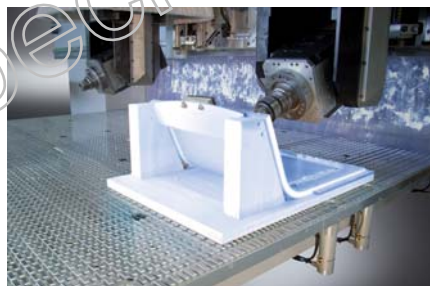

CAD/CAM systems

Data links are available to all commonly used CAD/CAM system manufacturers, allowing “simple” program generation of even the most complex 3D shaped components with a high degree of reliability and minimal expense

collisionControl

With the latest control and programming generation from HOMAG, collision monitoring is now also possible during 5-axis processing, offering optimum protection for tools and workpieces, the machine and the operator

Precision in every dimension

Traced profiling of even cambered workpieces is possible using the patented pneumatic interface, the DRIVE5+ five-axis spindle

Nesting

Panel dividing on a processing centre involves “nesting” the workpieces in optimum formation inside each other. This cutting waste optimization method helps to maximize material yield – allowing more efficient use of raw materials.



BOF 612 with two independent trimming spindles and two matrix tables accessible from three sides

The higher the quality of the materials used and the smaller the batch sizes, the faster an investment in nesting technology (panel dividing using a processing centre) will pay dividends. Rectangular and free-form components can be efficiently nested in the optimum configuration without consideration of the cutting patterns which have to be observed for sawing. By performing additional processing operations during the panel dividing process, such as drilling, handling periods are saved and costs reduced. HOMAG is able to offer a widely varied fund of experience from different sectors:

- Production of fronts – panel dividing and profiling
- Carcase production – panel dividing and drilling operations
- Staircase construction – dividing gluelam panels for staircase treads
- Vehicle interior fittings – panel dividing for yacht and caravan interiors
- Musical instruments and audio equipment furniture – complete processing of items such as speaker cabinets from an unfinished panel



HSC spindles with cleaning air jets

- Trimming spindles with speeds of up to 24,000 rpm are available for high feed rates and high workpiece quality
- Cleaning air jets at the dust hoods and tool holders take care of optimum chip disposal

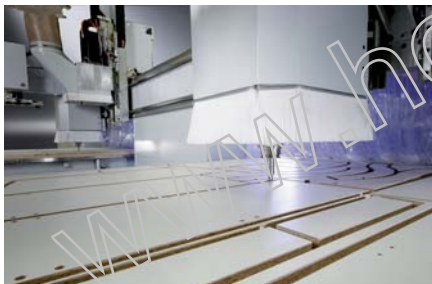

woodNest

- woodNest offers cutting waste optimization of shaped components and rectangular workpieces to ensure optimum material yield
- Data transmission in conjunction with all popularly used ERP systems helps reduce programming input
- Programmable calibration cycle for wearing panels

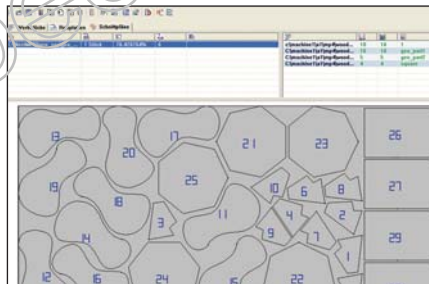

Suction beam

- A special suction beam permits fully automatic workpiece handling including waste pieces

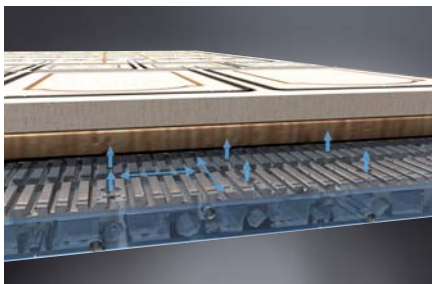

Matrix table

- The aluminium matrix table provides the ideal basis, not only for nesting applications
- In conjunction with an air cushion function, even large-scale workpieces and raw panels can be handled with the utmost simplicity



Storage system integration

Fully automatic dividing centres including part identification, waste part management, waste part disposal and spoil board handling can be configured in conjunction with a surface area storage system such as those supplied by BARGSTEDT



Workpiece cleaning

An integrated cleaning device automatically cleans the finished workpieces and spoil boards prior to positioning the next workpieces

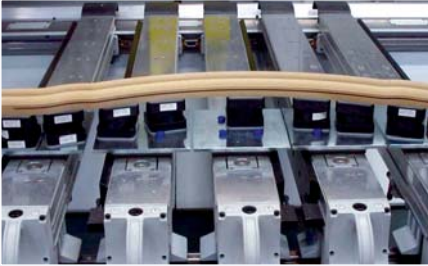

The Maxi-Flex clamping system creates a cohesive platform for optional clamp positioning



Even narrow, curved parts can be safely clamped using the Maxi-Flex clamping system



Flexible clamping system:
Stop bolts with swivel stops for workpieces with overhanging top layer (option)

Console table for precise, flexible part fixture

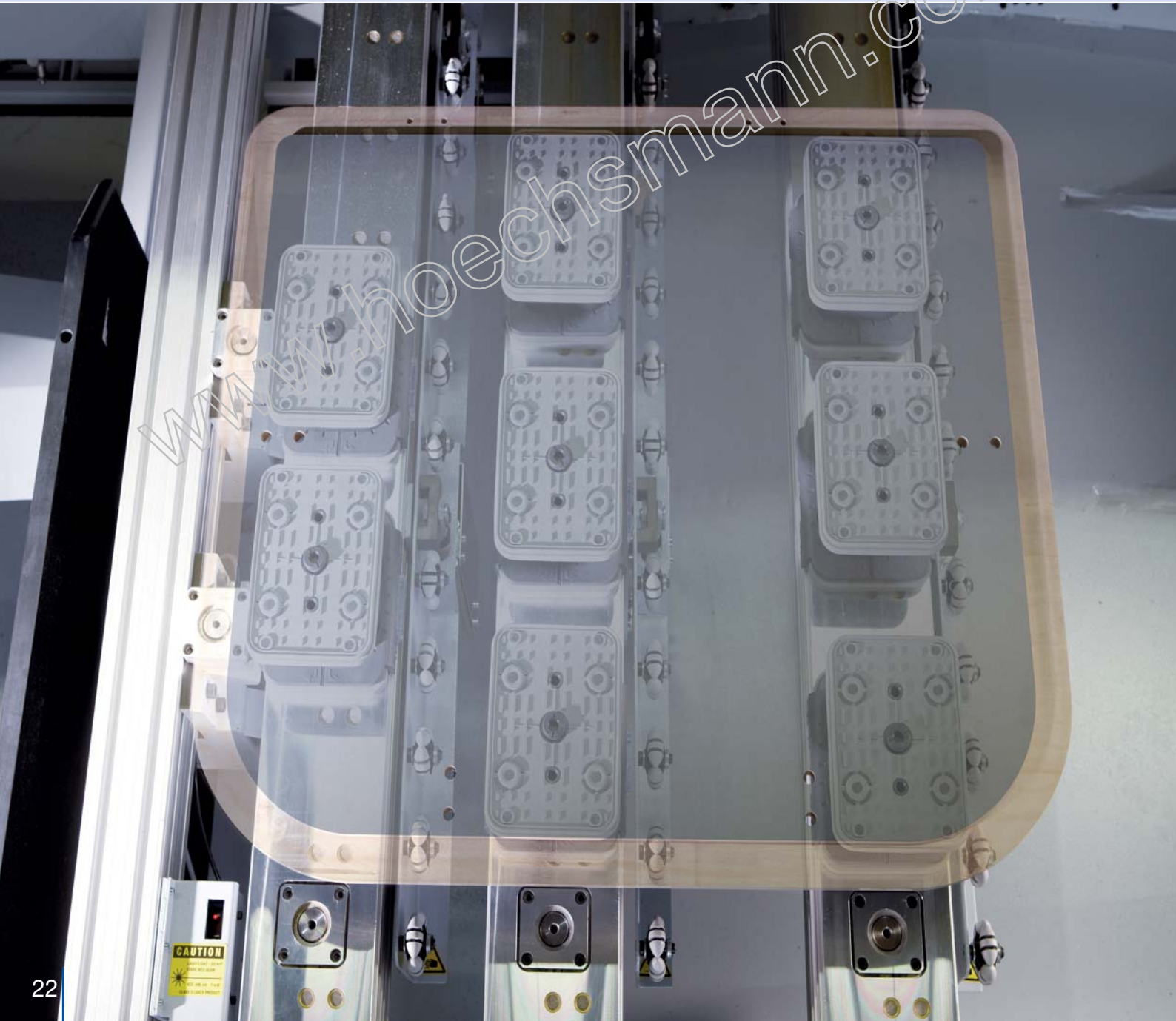

The right table for every assignment

HOMAG offers a range of innovative, practically oriented table variants for wide-ranging different requirements, making the precise fixture of workpieces simplicity itself. Extreme processing precision and perfect product quality are the result.



LED positioning system– the fastest, most reliable system compared to all alternative systems for manual positioning of vacuum clamps and consoles



Manual clamping devices for straight and curved parts. Ideal for window production



More information is provided in our processing unit and clamping element catalogue

Fast, neat and convenient – the console table

- Fast console adjustment in a single movement
- Variable number of vacuum clamps due to hoseless vacuum system
- Highly rigid consoles for precise part fixture and optimum processing precision
- No jamming when traversing consoles due to four linear guide carriages per console
- Generous clearance for waste pieces under the consoles
- Stop bolt position inside the machine bed, waste pieces and chips drop inside the waste piece disposal area

Greater output with flexible clamping systems

The exclusive vacuum clamp platform with patented double sealing lip for console clamping technology:

- For stepless displacement of hoseless vacuum clamps along the console
- Independence from suction points in the console
- Dual circuit vacuum system prevents unwanted displacement of vacuum clamps when positioning parts

Saves time and enhances flexibility: The AP automatic positioning table

AP – automatic positioning – provides the key to greater convenience, faster set-up and optimized processing steps (B700). The automatic positioning of clamps permits operations such as moving workpieces apart after a separating cut.

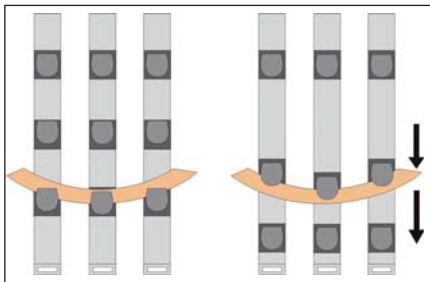

Automatic reclamping of individual parts for double-sided processing

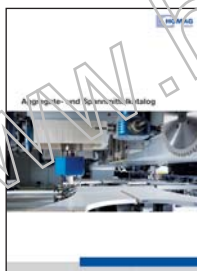
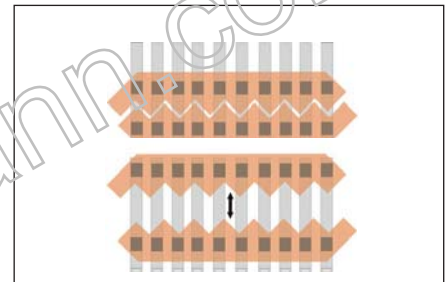
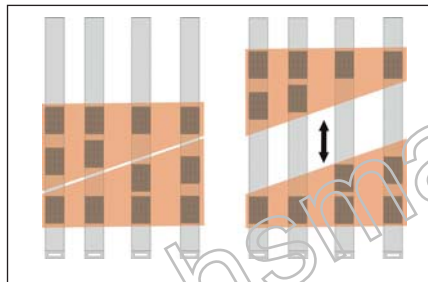

More information is provided in our processing unit and clamping element catalogue

Less setting up, more output – the AP table

- Fully automatic table set-up, including precisely positioned clamping elements
- Facility for resetting the work table during workpiece changeover
- Substantially reduced downtimes
- High output and efficiency even for batch size 1
- Facility for expansion to create a low-manned production cell
- Use of different types of vacuum clamps
- For wide-ranging workpiece geometries

The AP table offers wide-ranging scope for different applications such as staircase production, for instance for moving treads apart for complete processing following a separating cut. In the field of window construction, 5-sided processing can be performed without manual intervention by means of manual reclamping



Automatic cutting and separation of staircase treads for all-round complete processing



Different vacuum and pneumatic clamping elements guarantee precise processing of different workpieces and materials



The pneumatic clamps are traversed after longitudinal profiling of parts such as window staves in the Y direction for 5-sided processing

Fully automatic AP table, patented

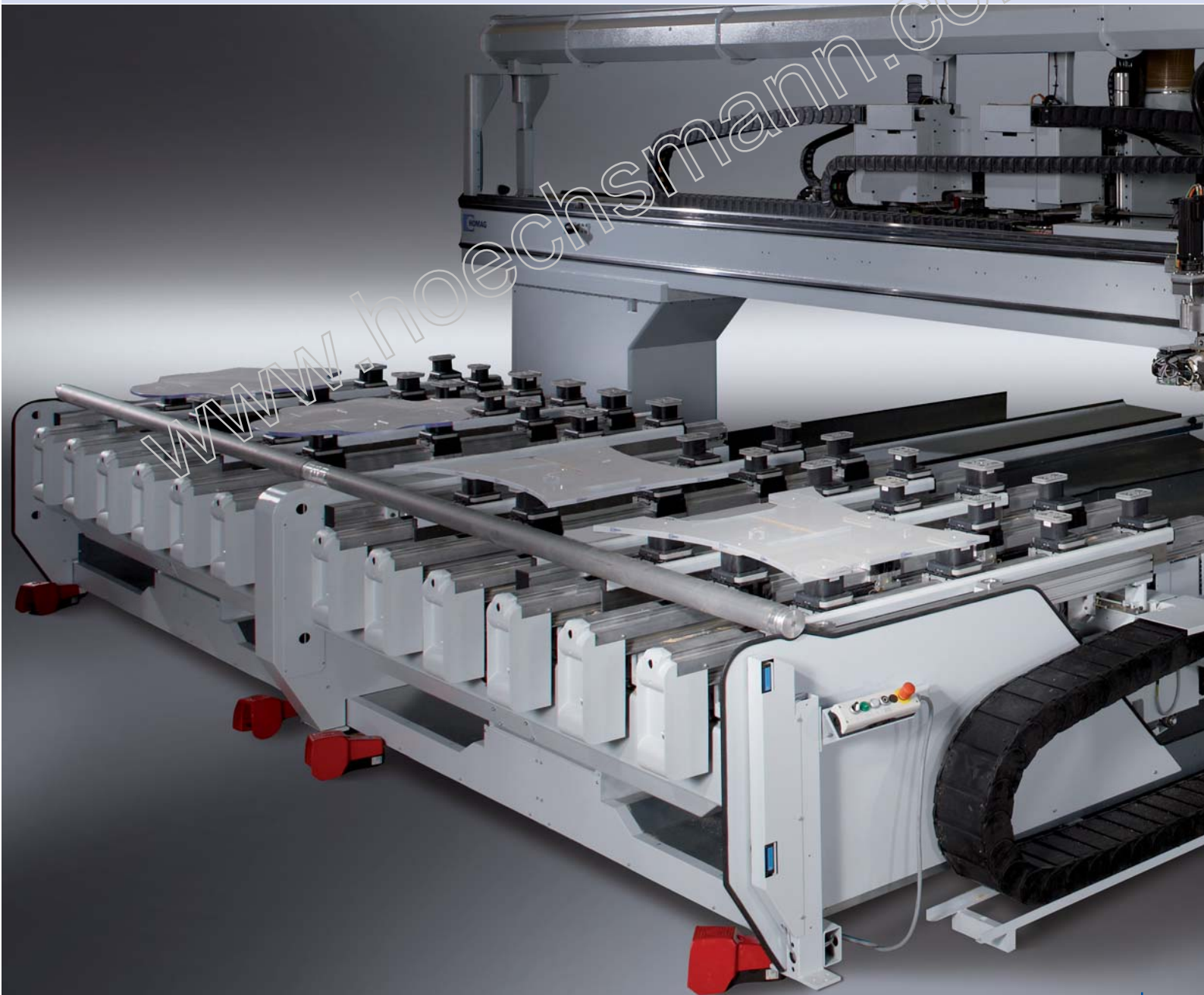

Vacuum clamps and sealing cords for flexible clamping of workpieces

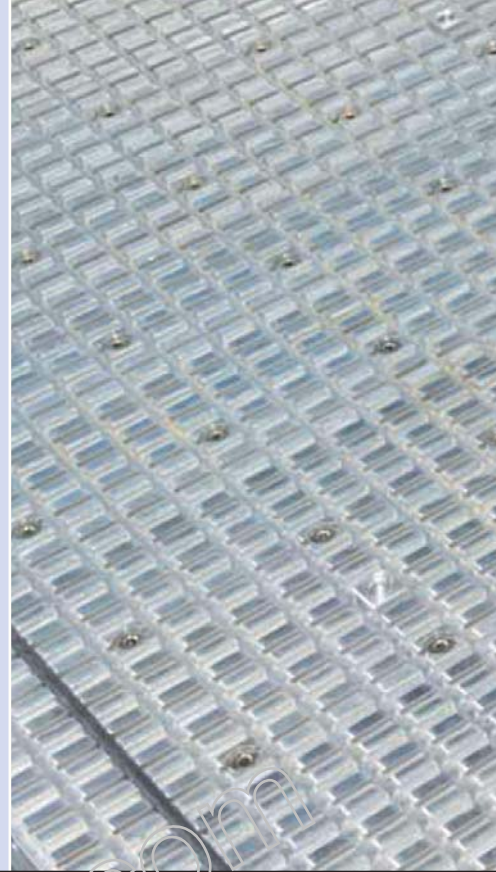

Versatile application: the matrix table

The grooved aluminium matrix table permits the positive locking of clamping elements and consequently reliable workpiece fixture even where high hogging forces are involved. The transmission of vacuum through the table construction optimizes distribution of the vacuum, reduces leaks and transmission losses and does away with the need for complex installations.

Using different clamps with variable clamping heights, the matrix table is also suitable for the use of units.

More information is provided in our processing unit and clamping element catalogue



Matrix table – the universal standard solution

- Precise, flexible adjustment of the vacuum suction surface to the contours of the workpiece
- Sealing cord for insertion in the grooves ensures all-over workpiece surface contact
- Facility for narrow edge processing through the use of plug-on vacuum clamps

- Precise workpiece positioning using stop pins
- Reliable part fixture even under exposure to high hogging forces due to dovetail grooves
- Facility for workpiece clamping with spoil board using the nesting technique

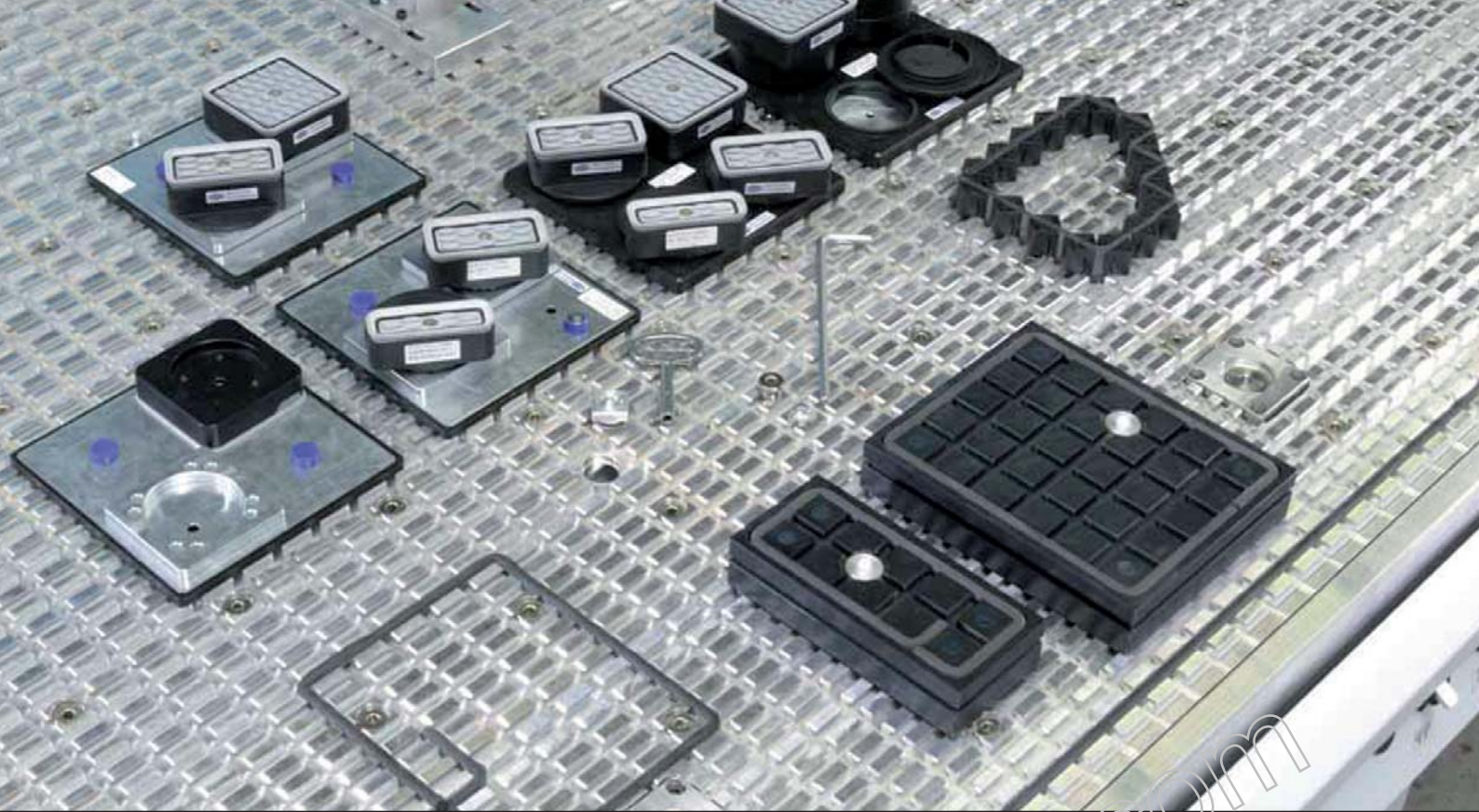

techsmann.com

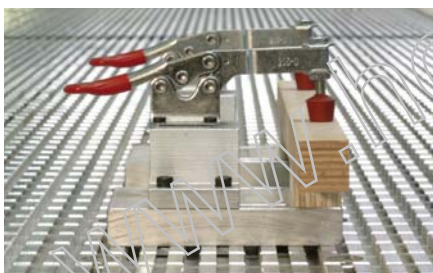

Grooved aluminium matrix table guarantees precise fixture through mechanical clamping elements in any optional location

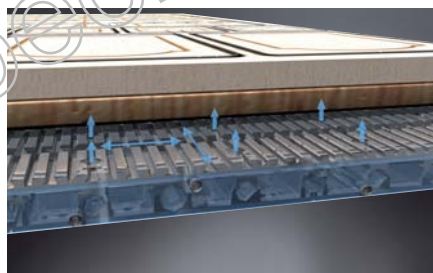

Air cushion function for easy handling of large-format workpieces



Synchronous processing during the nesting of carcase furniture components



Staircase stringer processing on Flex-System

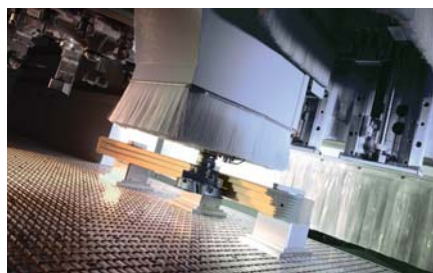

Window production with multi clamp



The Flex System also permits reliable fixture of curved workpieces such as washbasin units made of Corean

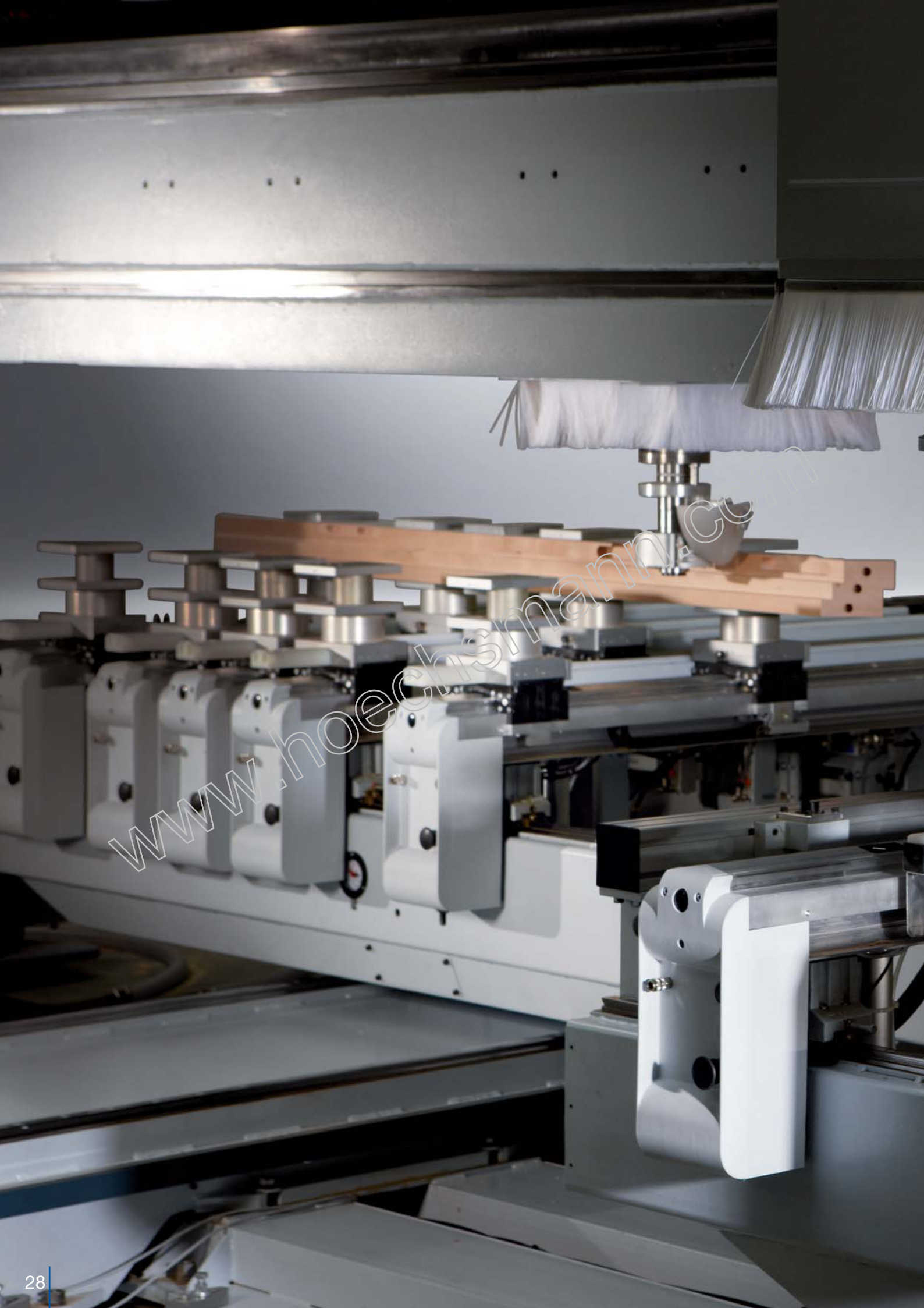



Our drilling technology with its modular design opens up added processing scope. Offering a durable design, varying numbers of spindles and additional functions such as trimming and sawing, it ideally combines high flexibility and economy. The multifunction capability of the Multi Processing Unit permits

sizing, sawing and drilling without tool changes. As the MPU affords 360° swivel capability, these processing operations can even be performed at “any” angle. While the MPU is operational, tools can be exchanged into the working spindle, drastically reducing downtimes in favour of higher productivity and lower piece costs.

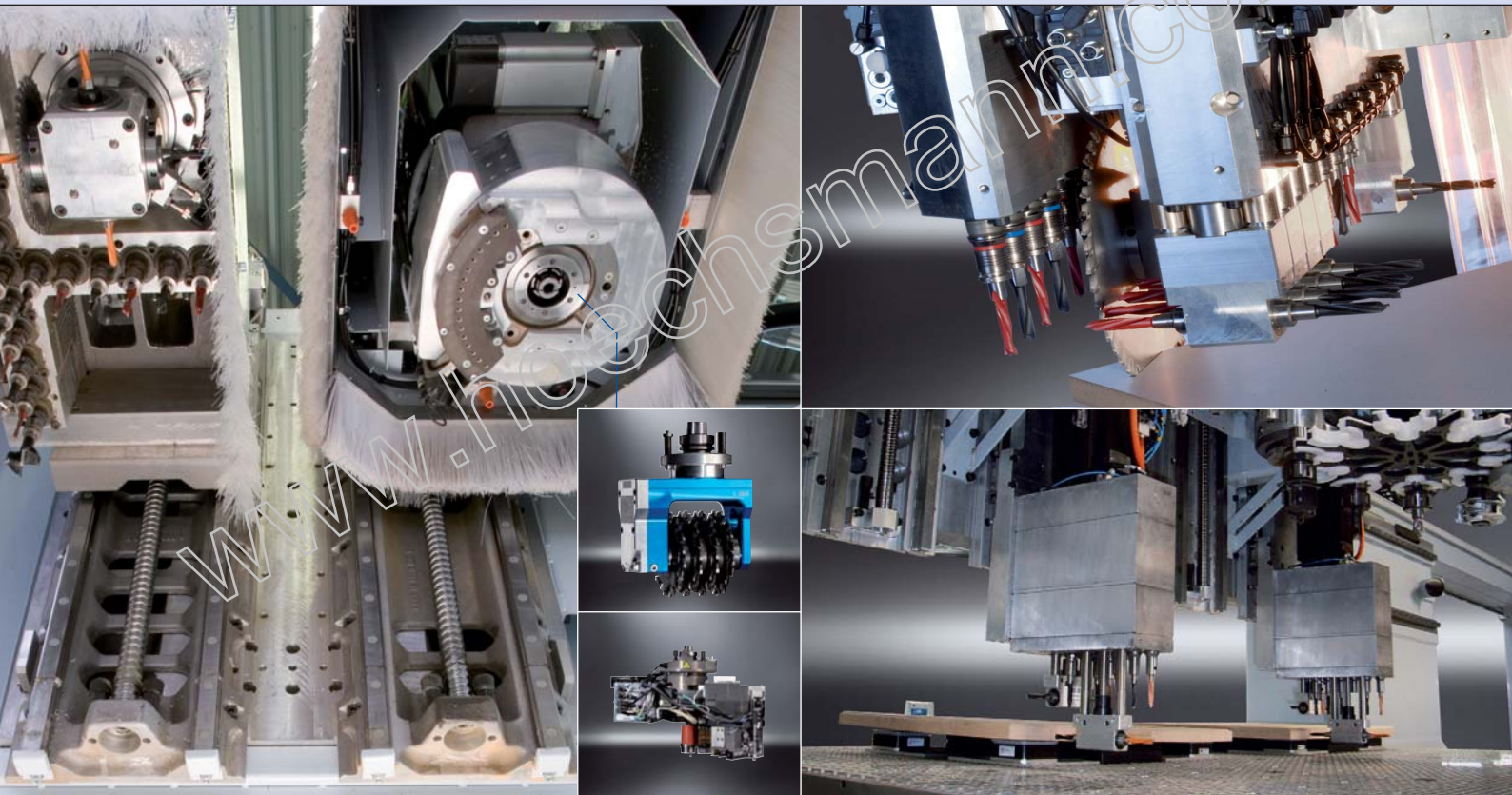

Unit and electronic interface for the flexible deployment of different units

- Trimming units
- Finish processing units
- Different gluing units such as
 - **doubleEdge** for lightweight construction (patented)
 - **edgeFolding** for butt joint-free edging of rectangular workpieces
 - **powerEdge** for high output using different edging materials and narrow contours

High-speed drilling heads

- Compact with 13 spindles for minimal spindle spacing during synchronous processing
- Versatile with 21 spindles and swivel-action grooving saw
- MPU – Multi Processing Unit for drilling, trimming, sawing without tool change



edgeFolding unit



doubleEdge unit

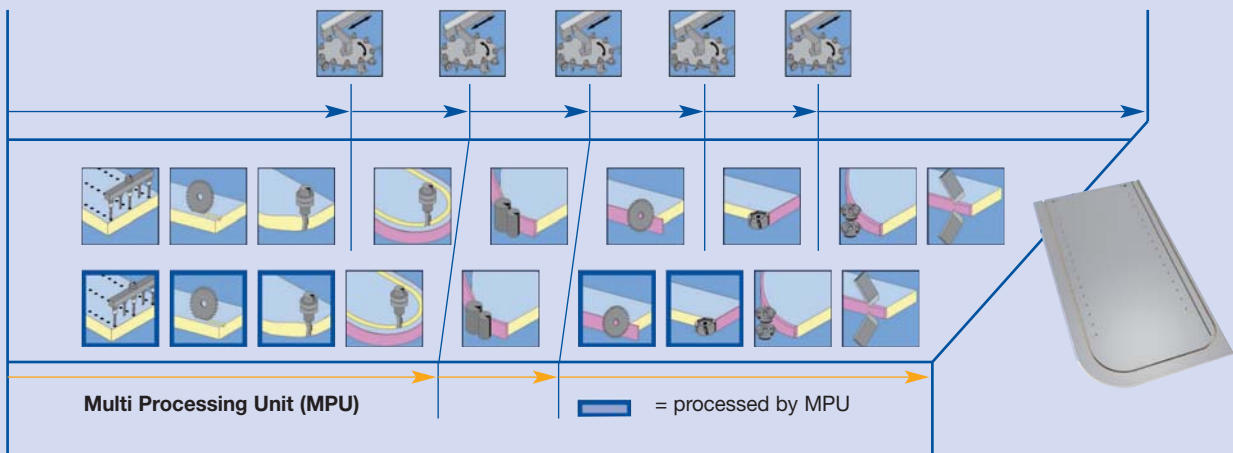

1 - 4 processing units

Up to four processing units with two Z axes each to accommodate different trimming spindles, drilling heads, gluing units or assembly units provide the basis for optimum adjustment of processing centres and the necessary process technology to your specific performance requirements. In conjunction with tool and unit storage systems providing up to 432 slots, every workpiece can be processed at high speed without resetting to a high standard of quality.

Optionally 1 - 4 processing units





Edging magazine with coupled motion in the X direction with up to 6 coils or externally with up to 24 coils



Tool changing system with 10 - 218 slots per working spindle (depending on the configuration) for extreme processing efficiency without the need for manual intervention

Our working spindle technology sets whole new standards, enhancing both the performance and flexibility of our machines. For instance the enormous benefit of a controlled working spindle with electronic speed monitoring and vibration sensor. Other highlights include the patented electronic interface, the **sensoFlex** tracing system and 5-axis technology. Select your spindle to suit the needs of your present and future product spectrum.



More information is provided in our processing unit and clamping element catalogue

Automation with robots from LIGMATECH –
Alongside pure workpiece handling, additional
functions such as labelling, position measuring,
finish processing (edge polishing) can also be
integrated.

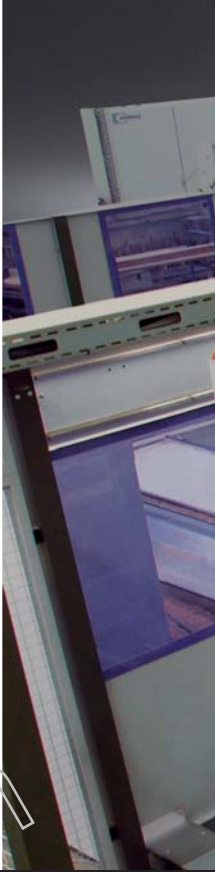

Feeder systems from HOMAG – the simplest way to create a production cell

Benefit from our leading technological edge to improve your competitive
standing: With the TBP 370 feeder. A HOMAG innovation to generate greater
operating convenience, flexibility and reliability.

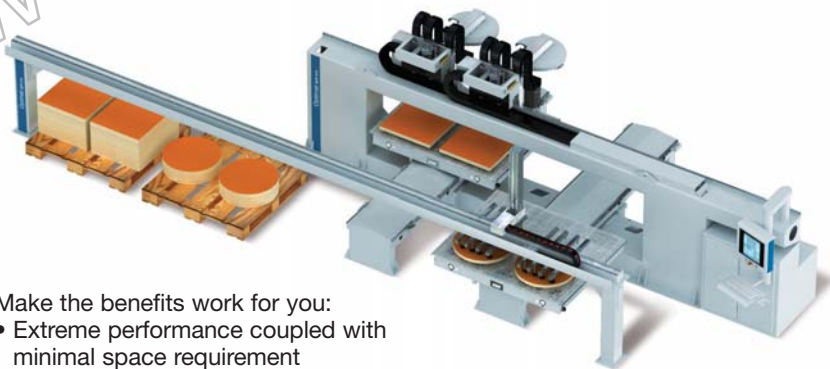

Make the benefits work for you:

- Extreme performance coupled with minimal space requirement
- Maximum flexibility – the patented systems can be individually upgraded
- Personnel savings, release of operators for other work
- Continued optimum accessibility for manual feeding (e. g. of non-standard components)
- Increase of machine running time (machine continuous producing also during operator break periods)

TBP 370 feeder in a synchronous version for linear gantries of
the B600 and B700 series

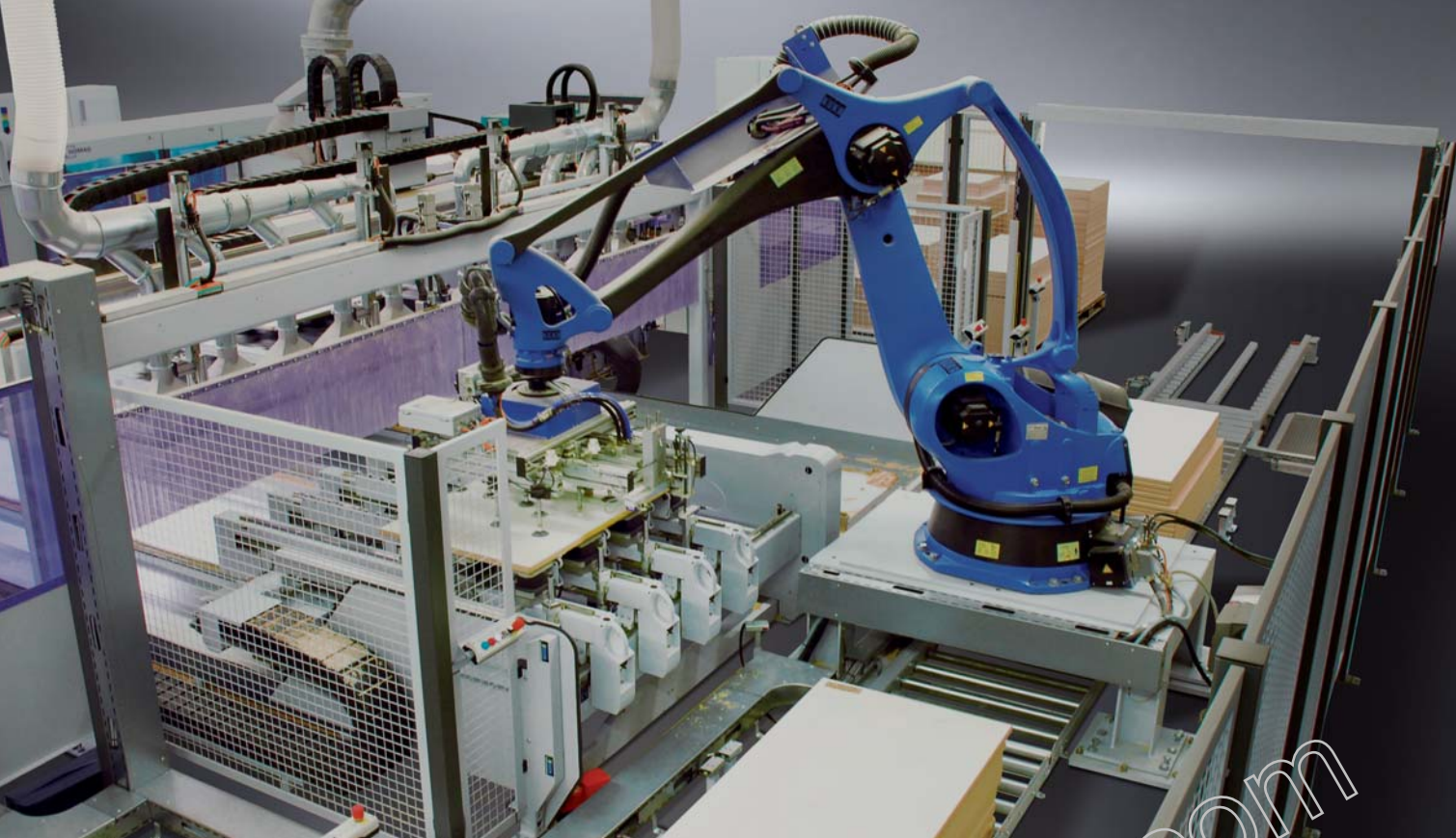

hohmann.com



Handling reliability

Intelligent choice of supplementary equipment ensures optimum process reliability



Workpiece positioning

Patented stop kinematics ensure that workpieces rest precisely against the stop bolts



Cleaning function

Workpieces are reliably cleaned of chips

- The optical drop sensor additionally detects adhering panels
- The gripper system is also available in a patented synchronous version, permitting double the output
- Reliable cleaning of chips from workpieces by a cleaning pass of the suction beam with a series of compressed air jets or by air jet cleaning with the processing unit
- Standard clamps with round silicone suction cups
- Nesting suction beam with foam grip area for high-tolerance clamping of different workpiece surfaces

Flexibility

Different stack patterns can be formed using a state-of-the-art user interface. In contrast to conventional systems, the feed process has been integrated fully into operation of the machine. These patented feed systems can also be retrofitted, opening up scope for an automated future

Programming software and machine control

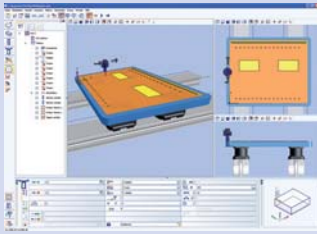

woodWOP – streamlined operations through fast programming

- Greater programming reliability using 3D graphic displays of workpiece processing operations and clamping elements
- Faster data input through simple, direct navigation
- Higher operating convenience through a redesigned user interface featuring freely adjustable windows, multiscreen capability, language-neutral input masks, graphic help functions and much more
- Biggest forum for CNC programming in the Internet: www.woodWOP-Forum.de

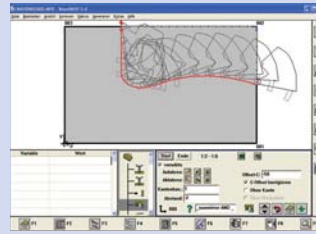

woodWOP-Wizard – your automatic route to the perfect edge

- Automatic generation of the processing sequence for edging
- Generation of all processing steps such as roughing, sizing, edging, snipping, flush trimming and scraping
- Takes into consideration workpiece geometry, edge transitions and edge type
- A standard feature of all HOMAG BAZ machines – experience the magic of woodWOP-Wizard



woodWOP production engineering station – programming from the comfort of the office

- Programming while ready generated programs are running on the machine
- Data transmission via standard USB port at the machine or over a network connection directly from the office

woodWOP DXF-Import – the CAD interface

- For transfer of workpiece geometries and defined processing operations
- Data transfer from CAD systems in international DXF format

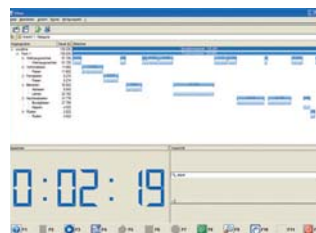

woodTime – simulation in a class of its own

- Simulation based on a virtual machine with real CNC core controlled by data from the relevant customer machine. This allows real CNC machine behaviour to be simulated with almost 100% accuracy in production engineering
- Simulation of all machine processing operations at the workpiece including stock removal
- Simulation of 5-axis processing operations in woodWOP format and from external DIN codes
- Storage and transfer of simulation runs

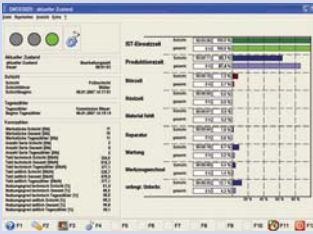

Machine data acquisition MDA – for a productive environment

- Registration of piece numbers and ACTUAL operating times at the machine
- Integrated maintenance indication for optimum planning and execution of necessary maintenance work
- Optional professional version permits detailed breakdown and logging of registered data

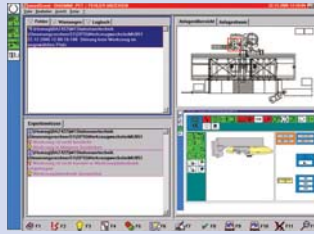

woodScout – help in your own language

- Optional high-performance diagnostic system
- Graphic display of the fault location at the machine
- Easily understandable plain text error messages in different languages
- Learning capability through the assignment of root causes and remedial actions (expert knowledge)



Tool service life determination – for a complete overview

- Module for monitoring and documentation of tool service life
- Machine availability and workpiece quality are enhanced by the timely exchange of tools
- Cost reduction through optimum planning of tool deployment and comparative analysis of tool life

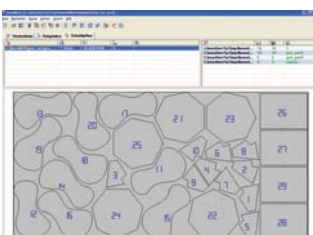

woodNest – reduction of cutting waste

- Nesting software for automatic interleaving of workpieces on a raw panel
- The nesting technique combines cutting and finish processing
- Reduced material costs and overall processing times

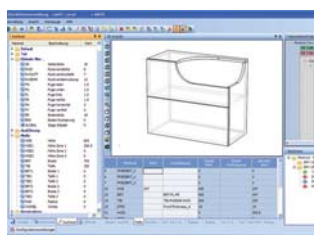

Interface to trade-specific software

- For trouble free linkup of trade-specific software packages
- For transfer of already existing data from production engineering
- Countless links to all reputable room planning systems, window trade-specific software, staircase software, CAD/CAM systems and ERP/ MRP systems

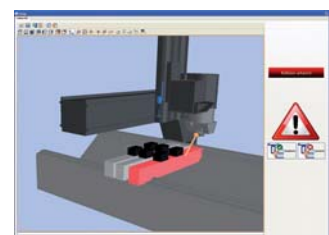

collisionControl – permanent safety for your machine

- Monitors possible collisions between machine components and clamps at the machine during processing
- Automatic machine stop in the event of an impending crash situation
- Display of the crash situation in the form of a snapshot with collision bodies shown up in colour
- Depiction of the machine as a moving 3D model in live operation

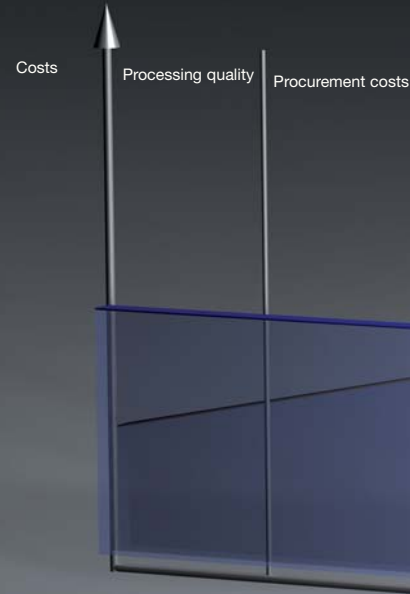

LifeCycle Cost reduces unit costs

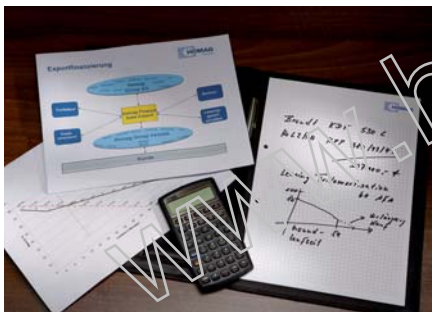

Unit cost reduction through

Optimum financing

- HOMAG Finance offers optimized financing concepts based on individual business administration requirements
- The outstanding value stability of HOMAG processing centres offers benefits in terms of leasing and subsequent replacement investment

High-quality processing “without” finish processing

- A highly mature solid machine construction made of innovative SORB TECH-material reduces vibrations and increases tool life by up to 20 %
- Vibration sensors in the working spindles automatically reduce feed rates under high levels of stress (such as knots in solid wood) or in case of unbalanced tools
- Tool life determination software optimizes tooling costs and optimum workpiece quality

Reduction of labour costs

- Automatic part handling with robot systems or linear feeders
- Fast, simple operating capability of machines

High degree of machine availability

- World-wide round-the-world service reduces machine downtimes
- TeleServiceNet – our “eye” into the machine eliminates the need for costly service callouts
- woodScout diagnostic software – intelligent self-help for all machine operators

Low energy costs

- Intelligent stand-by operation reduces energy costs during break times or in case of partial capacity utilization by up to 10 %, saving up to 8,000 kwh of power per year*
- A flap control system switches the volumetric flow of the extraction system to the processing units in use, reducing extraction costs by up to 20 %, corresponding to energy savings of up to 12, 000 kwh per year*
- Cooling of the working spindle by means of water ring vacuum pumps saves an additional 2,000 kwh per year*



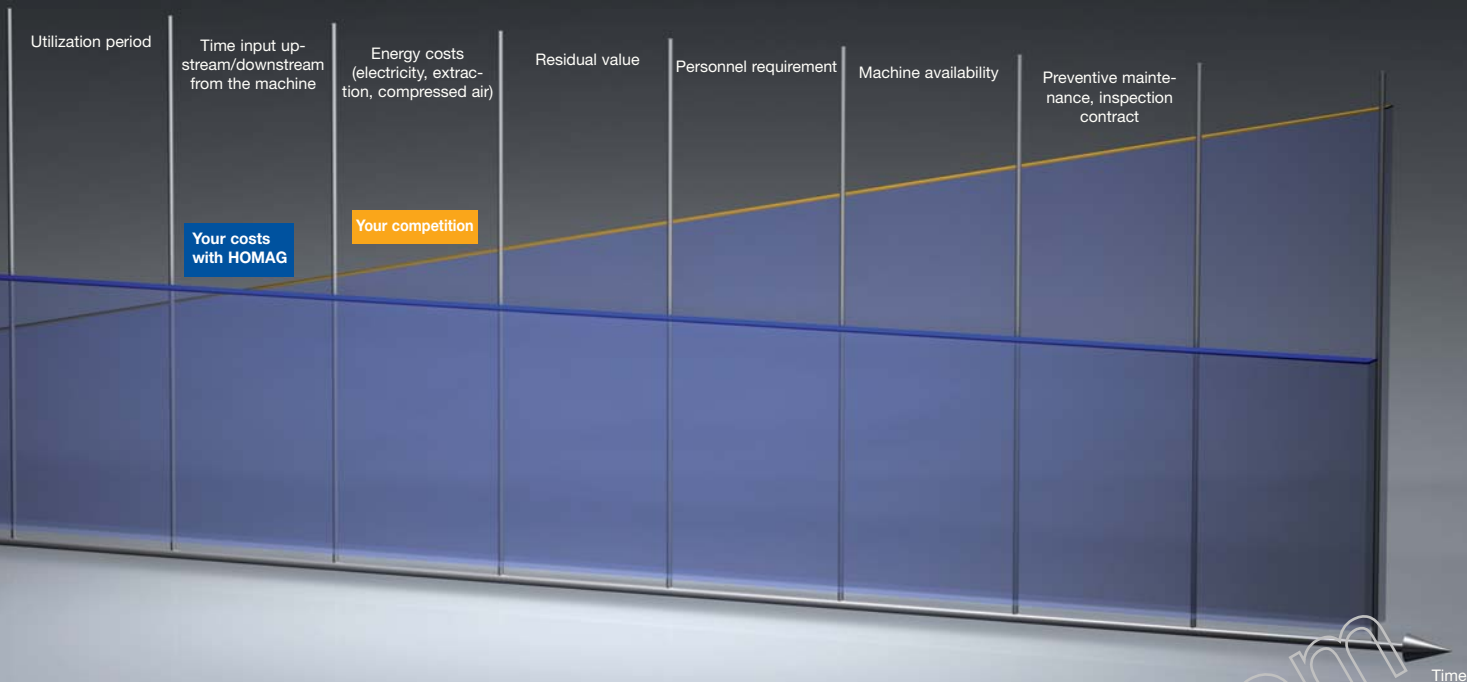

Machine utilization period

- Facility for continuous upgrading of processing centre functionality using standardized interfaces ensures compliance with future production requirements
- The HOMAG modification department offers solutions to address major conversion requirements, ensuring a high degree of investment security over years

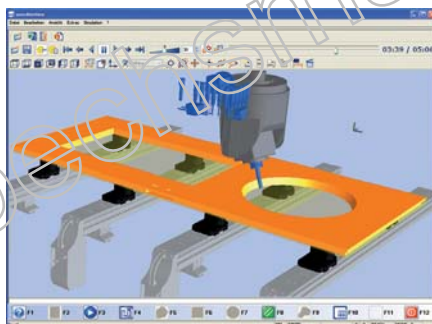

Effective production engineering

- Links to trade-specific software packages and CAD/CAM systems reduce program generation times and make use of already existing data
- woodMotion determines processing times for optimum capacity planning and maximum machine time utilization
- Collision monitoring prevents faults by advance testing of programs under "real conditions"

Preventive maintenance

- Regular inspections and preventive maintenance help avoid machine faults and extend service life
- MDA software informs the machine operator about scheduled maintenance requirements and provides cost transparency for calculation

* Based on a BOF 722 in single-shift operation

Compact and efficient

Patented safety technology without the use of safety mats substantially reduces the amount of space required by the machines (exception: B6xx/21xx). This eliminates the risk of unintentional entry into the danger area, as EMERGENCY STOP situations can no longer

occur. Damage to safety mats or workpiece pallets are effectively prevented using this new safety technology, allowing workpiece pallets to now be placed within reach. Feed rollers have been integrated as insertion aids, allowing easy loading even for bigger workpieces.

Technical data B600

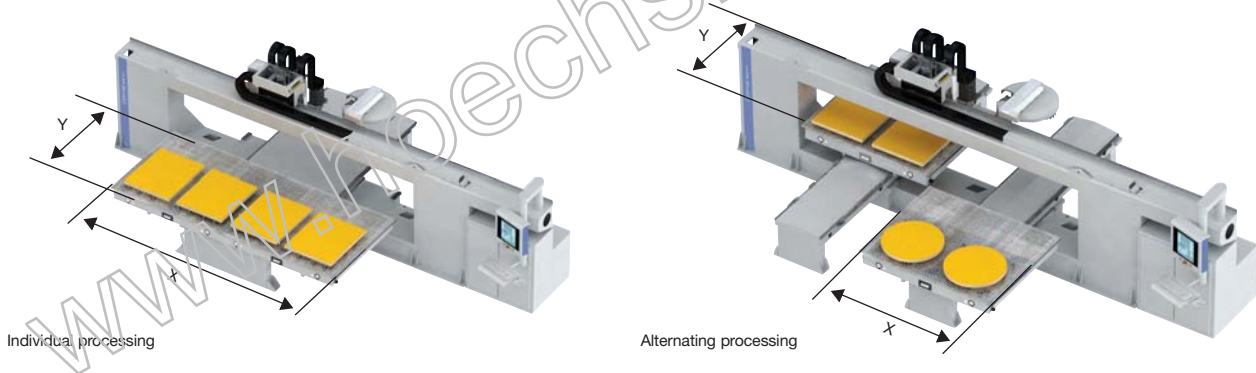

| Machine type | X = Workpiece length [mm] | | | | Y = Workpiece width [mm] | | Workpiece thickness incl. clamps |
|------------------|---------------------------|---------------|---------------------------|---------------|--------------------------|----------------|----------------------------------|
| | Individual processing | | Alternating processing CE | | Tool diameter 25 mm | All Units [mm] | |
| | 34 | 21 | 34 | 21 | | | |
| BOF 6xx/xx/13/2K | 3.470 (136,6") | - | 1.700 (66,9") | - | 1.550 (61,0") | 1.300 (51,2") | 300 (11,8") |
| BOF 6xx/xx/13/2R | 3.440 (135,4") | - | 1.680 (66,1") | - | 1.550 (61,0") | 1.300 (51,2") | 300 (11,8") |
| BOF 6xx/xx/31/2R | - | 2.100 (82,7") | - | 2.100 (82,7") | 3.100 (122,0") | 3.100 (122,0") | 300 (11,8") |
| BOF 6xx/xx/34/2R | 3.440 (135,4") | - | 1.680 (66,1") | - | 3.710 (146,1") | 3.560 (140,2") | 300 (11,8") |
| BOF 6xx/xx/37/2R | - | 2.100 (82,7") | - | 2.100 (82,7") | 3.710 (146,1") | 3.700 (145,7") | 300 (11,8") |

Technical data and photos are not binding in every detail. We reserve the express right to make changes in the interests of further development.



Technical data B700

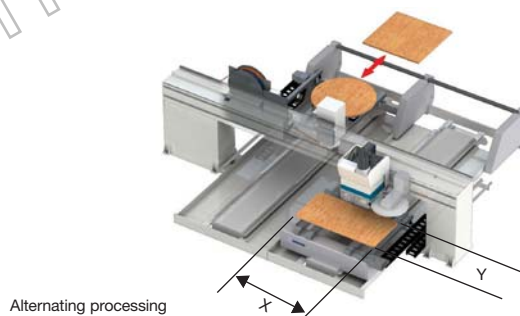
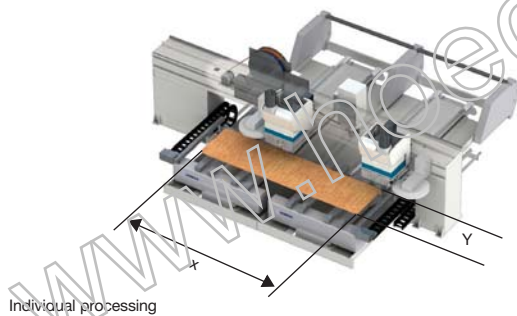

| Machine type | X = Workpiece length [mm] | | | | | | | | Y = Workpiece width [mm] | | |
|------------------------|---------------------------|-------------------|-------------------|-------------------|---------------------------|------------------|-------------------|-------------------|--------------------------|-------------------|-------------------------------------|
| | Individual processing | | | | Alternating processing CE | | | | Tool diameter 25 mm | All Units [mm] | Workpiece thickness incl. clamps |
| | 32 | 42 | 48 | 58 | 32 | 42 | 48 | 58 | | | |
| BOF 711/xx/16/ K+AP | - | 4.200 (165,4") | - | 5.860 (230,7") | - | 2.040 (80,3") | - | 2.870 (113,0") | 1.825 (71,9") | 1.600 (63,0") | 300 (11,8") / 500 (19,7") |
| BOF 711/xx/18/ K+AP | - | 4.200 (165,4") | - | 5.860 (230,7") | - | 2.040 (80,3") | - | 2.870 (113,0") | 2.075 (81,7") | 1.850 (72,8") | 300 (11,8") / 500 (19,7") |
| BOF 712/xx/16/ K+AP | 3.200 (126,0") | 4.200 (165,4") | 4.950 (194,9") | 5.860 (230,7") | 2.040 (80,3") | 2.040 (80,3") | 2.870 (113,0") | 2.870 (113,0") | 1.825 (71,9") | 1.600 (63,0") | 300 (11,8") / 500 (19,7") |
| BOF 712/xx/38/ K+AP | 3.200 (126,0") | 4.200 (165,4") | 4.950 (194,9") | 5.860 (230,7") | 2.040 (80,3") | 2.040 (80,3") | 2.870 (113,0") | 2.870 (113,0") | 2.075 (81,7") | 1.850 (72,8") | 300 (11,8") / 500 (19,7") |
| BOF 713/xx/16/K | - | - | - | 5.860 (230,7") | - | - | - | 2.680 (105,5") | 1.825 (71,9") | 1.600 (63,0") | 300 (11,8") / 500 (19,7") |
| BOF 713/xx/18/K | - | - | - | 5.860 (230,7") | - | - | - | 2.680 (105,5") | 2.075 (81,7") | 1.850 (72,8") | 300 (11,8") / 500 (19,7") |
| BOF 714/xx/16/K | - | - | - | 5.860 (230,7") | - | - | - | 2.680 (105,5") | 1.825 (71,9") | 1.600 (63,0") | 300 (11,8") / 500 (19,7") |
| BOF 714/xx/18/K | - | - | - | 5.860 (230,7") | - | - | - | 2.680 (105,5") | 2.075 (81,7") | 1.850 (72,8") | 300 (11,8") / 500 (19,7") |



Technical data B700

| Machine type | X = Workpiece length [mm] | | | | | | | | Y = Workpiece width [mm] | | |
|------------------------|---------------------------|-------------------|-------------------|-------------------|---------------------------|------------------|-------------------|-------------------|--------------------------|-------------------|-------------------------------------|
| | Individual processing | | | | Alternating processing CE | | | | Tool diameter 25 mm | All Units [mm] | Workpiece thickness incl. clamps |
| | 32 | 42 | 48 | 58 | 32 | 42 | 48 | 58 | | | |
| BOF 722/xx/16/ K+AP | - | 4.200 (165,4") | - | 5.860 (230,7") | - | 2.040 (80,3") | - | 2.870 (113,0") | 1.825 (71,9") | 1.600 (63,0") | 300 (11,8") / 500 (19,7") |
| BOF 722/xx/18/ K+AP | - | 4.200 (165,4") | - | 5.860 (230,7") | - | 2.040 (80,3") | - | 2.870 (113,0") | 2.075 (81,7") | 1.850 (72,8") | 300 (11,8") / 500 (19,7") |
| BOF 723/xx/16/ K+AP | - | - | - | 5.860 (230,7") | - | - | - | 2.870 (113,0") | 1.825 (71,9") | 1.600 (63,0") | 300 (11,8") / 500 (19,7") |
| BOF 723/xx/18/ K+AP | - | - | - | 5.860 (230,7") | - | - | - | 2.870 (113,0") | 2.075 (81,7") | 1.850 (72,8") | 300 (11,8") / 500 (19,7") |
| BOF 711/xx/16/R | - | 4.200 (165,4") | - | 5.900 (232,3") | - | 2.055 (80,9") | - | 2.900 (114,2") | 1.950 (76,8") | 1.600 (63,0") | 300 (11,8") / 500 (19,7") |
| BOF 711/xx/18/R | - | 4.200 (165,4") | - | 5.900 (232,3") | - | 2.055 (80,9") | - | 2.900 (114,2") | 2.200 (86,6") | 1.850 (72,8") | 300 (11,8") / 500 (19,7") |
| BOF 711/xx/22/R | - | 4.200 (165,4") | - | 5.900 (232,3") | - | 2.055 (80,9") | - | 2.900 (114,2") | 2.550 (100,4") | 2.250 (88,6") | 300 (11,8") / 500 (19,7") |
| BOF 712/xx/16/R | 3.200 (126,0") | 4.200 (165,4") | 4.950 (194,9") | 5.900 (232,3") | 2.055 (80,9") | 2.055 (80,9") | 2.900 (114,2") | 2.900 (114,2") | 1.950 (76,8") | 1.600 (63,0") | 300 (11,8") / 500 (19,7") |
| BOF 712/xx/18/R | 3.200 (126,0") | 4.200 (165,4") | 4.950 (194,9") | 5.900 (232,3") | 2.055 (80,9") | 2.055 (80,9") | 2.900 (114,2") | 2.900 (114,2") | 2.200 (86,6") | 1.850 (72,8") | 300 (11,8") / 500 (19,7") |
| BOF 712/xx/22/R | 3.200 (126,0") | 4.200 (165,4") | 4.950 (194,9") | 5.900 (232,3") | 2.055 (80,9") | 2.055 (80,9") | 2.900 (114,2") | 2.900 (114,2") | 2.550 (100,4") | 2.250 (88,6") | 300 (11,8") / 500 (19,7") |
| BOF 713/xx/16/R | - | 4.200 (165,4") | - | 5.900 (232,3") | - | 2.055 (80,9") | - | 2.900 (114,2") | 1.950 (76,8") | 1.600 (63,0") | 300 (11,8") / 500 (19,7") |
| BOF 713/xx/18/R | - | 4.200 (165,4") | - | 5.900 (232,3") | - | 2.055 (80,9") | - | 2.900 (114,2") | 2.200 (86,6") | 1.850 (72,8") | 300 (11,8") / 500 (19,7") |
| BOF 713/xx/22/R | - | 4.200 (165,4") | - | 5.900 (232,3") | - | 2.055 (80,9") | - | 2.900 (114,2") | 2.550 (100,4") | 2.250 (88,6") | 300 (11,8") / 500 (19,7") |
| BOF 714/xx/16/R | - | - | - | 5.900 (232,3") | - | - | - | 2.900 (114,2") | 1.950 (76,8") | 1.600 (63,0") | 300 (11,8") / 500 (19,7") |
| BOF 714/xx/18/R | - | - | - | 5.900 (232,3") | - | - | - | 2.900 (114,2") | 2.200 (86,6") | 1.850 (72,8") | 300 (11,8") / 500 (19,7") |
| BOF 714/xx/22/R | - | - | - | 5.900 (232,3") | - | - | - | 2.900 (114,2") | 2.550 (100,4") | 2.250 (88,6") | 300 (11,8") / 500 (19,7") |

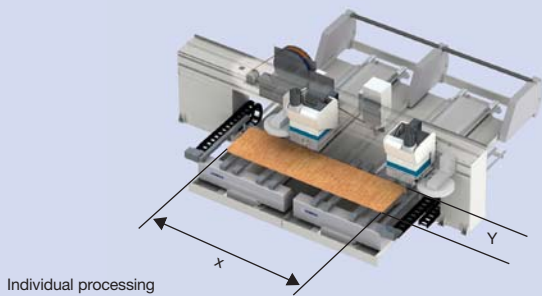

Individual processing

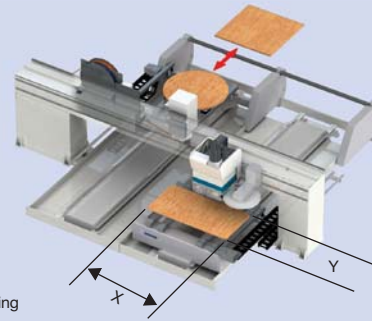

Alternating processing

| Machine type | X = Workpiece length [mm] | | | | | | | | Y = Workpiece width [mm] | | |
|-----------------|---------------------------|-------------------|----|-------------------|---------------------------|------------------|----|-------------------|--------------------------|-------------------|-------------------------------------|
| | Individual processing | | | | Alternating processing CE | | | | Tool diameter 25 mm | All Units [mm] | Workpiece thickness incl. clamps |
| | 32 | 42 | 48 | 58 | 32 | 42 | 48 | 58 | | | |
| BOF 722/xx/16/R | - | 4.200 (165,4") | - | 5.900 (232,3") | - | 2.055 (80,9") | - | 2.900 (114,2") | 1.950 (76,8") | 1.600 (63,0") | 300 (11,8") / 500 (19,7") |
| BOF 722/xx/18/R | - | 4.200 (165,4") | - | 5.900 (232,3") | - | 2.055 (80,9") | - | 2.900 (114,2") | 2.200 (86,6") | 1.850 (72,8") | 300 (11,8") / 500 (19,7") |
| BOF 723/xx/16/R | - | - | - | 5.900 (232,3") | - | - | - | 2.900 (114,2") | 1.950 (76,8") | 1.600 (63,0") | 300 (11,8") / 500 (19,7") |
| BOF 723/xx/18/R | - | - | - | 5.900 (232,3") | - | - | - | 2.900 (114,2") | 2.200 (86,6") | 1.850 (72,8") | 300 (11,8") / 500 (19,7") |

| Machine type | X = Workpiece length [mm] | | | | | | Y = Workpiece width [mm] | | | Workpiece thickness incl. clamps |
|----------------------|---------------------------|-------------------|---------------------------|-------------------|-------------------------------|-------------------|--------------------------|---------------|---------------|-------------------------------------|
| | Individual processing | | Alternating processing CE | | Alternating processing Gluing | | Tool diameter 25 mm | All Units | Gluing | |
| | 42 | 58 | 42 | 58 | 42 | 58 | | | | |
| BAZ 722/xx/16/K+AP | 4.200 (165,4") | 5.860 (230,7") | 2.040 (80,3") | 2.870 (113,0") | 1.850 (72,8") | 2.680 (105,5") | 1.825 (71,9") | 1.600 (63,0") | 1.700 (66,9") | 300 (11,8") / 500 (19,7") |
| BAZ 722/xx/18/K+AP | 4.200 (165,4") | 5.860 (230,7") | 2.040 (80,3") | 2.870 (113,0") | 1.850 (72,8") | 2.680 (105,5") | 2.075 (81,7") | 1.850 (72,8") | 1.950 (76,8") | 300 (11,8") / 500 (19,7") |
| BAZ 722/xx/16/V/K+AP | 4.200 (165,4") | 5.860 (230,7") | 2.040 (80,3") | 2.870 (113,0") | 1.850 (72,8") | 2.680 (105,5") | 1.825 (71,9") | 1.600 (63,0") | 1.700 (66,9") | 300 (11,8") / 500 (19,7") |
| BAZ 722/xx/18/V/K+AP | 4.200 (165,4") | 5.860 (230,7") | 2.040 (80,3") | 2.870 (113,0") | 1.850 (72,8") | 2.680 (105,5") | 2.075 (81,7") | 1.850 (72,8") | 1.950 (76,8") | 300 (11,8") / 500 (19,7") |
| BAZ 723/xx/16/V/K+AP | 4.200 (165,4") | 5.860 (230,7") | 2.040 (80,3") | 2.870 (113,0") | 1.850 (72,8") | 2.680 (105,5") | 1.825 (71,9") | 1.600 (63,0") | 1.700 (66,9") | 300 (11,8") / 500 (19,7") |
| BAZ 723/xx/18/V/K+AP | 4.200 (165,4") | 5.860 (230,7") | 2.040 (80,3") | 2.870 (113,0") | 1.850 (72,8") | 2.680 (105,5") | 2.075 (81,7") | 1.850 (72,8") | 1.950 (76,8") | 300 (11,8") / 500 (19,7") |



A member of the HOMAG Group



HOMAG Holzbearbeitungssysteme AG

Homagstraße 3-5
72296 SCHOPFLOCH
GERMANY

Tel. +49 7443 13-0
Fax +49 7443 13-2300
info@homag.de
www.homag.com