

Big can be that small.

HE HOMAG

Our CNC Processing Center
DRILLTEQ V-200

YOUR SOLUTION







DRILLTEQ V-200 – big can be that small.

Fast processing – saves time

Takes up little room – saves space

Simple operation – saves nerves

Great value for money – saves money

Our CNC processing centers offer the technology of the future today. And with good reason: Tradition. For us, it is both a motivation and a commitment. Customers the world over associate the very highest standards with this. And we meet those expectations.

YOUR SOLUTION

MORE: [HOMAG.COM](https://www.homag.com)



CONTENTS

- 04 DRILLTEQ V-200 – tapio ready
- 06 Configurations
- 08 All inclusive – Hardware
- 10 All inclusive – Software
- 11 Option – Software
- 12 Option – Plausibility Check
- 13 Option – Length-dependent Processing
- 14 LifeCycleServices
- 15 Technical Data

Design meets digital. Can be connected to tapio.



Make use of the almost unlimited processing power of cloud-based technologies.
Apps for your solution: e.g. DataSave, ServiceBoard, MachineBoard

DataSave

DataSave makes smaller and larger data losses and the associated problems a thing of the past. The solution ensures that all the latest system data for the machines is stored in a central cloud and made immediately available as and when needed.

ServiceBoard

Get help fast. **ServiceBoard** ensures that errors can be identified quickly and easily with the aid of video diagnoses, so that a solution can be implemented straight away. ServiceBoard also makes it possible to remedy faults rapidly and where possible by yourself.

MachineBoard

Nobody is more closely involved with the machinery than the machine operators themselves. Downtime is not an option; delays are unwelcome – so much the better that they now have all the machine-related information to hand in real time. This helps you to make sure you can always get to the machine in good time and react flexibly at all times.

DRILLTEQ V-200



Just have a try:

Free use of the MachineBoard app! Just register under tapio and „connect“ the machine www.tapio.one.

The complimentary usage is limited in time. Due to fast pace of the IT-landscape, the compatibility to the tapio platform is warranted for five years.

tapio
Partner

Equipment packages for V8

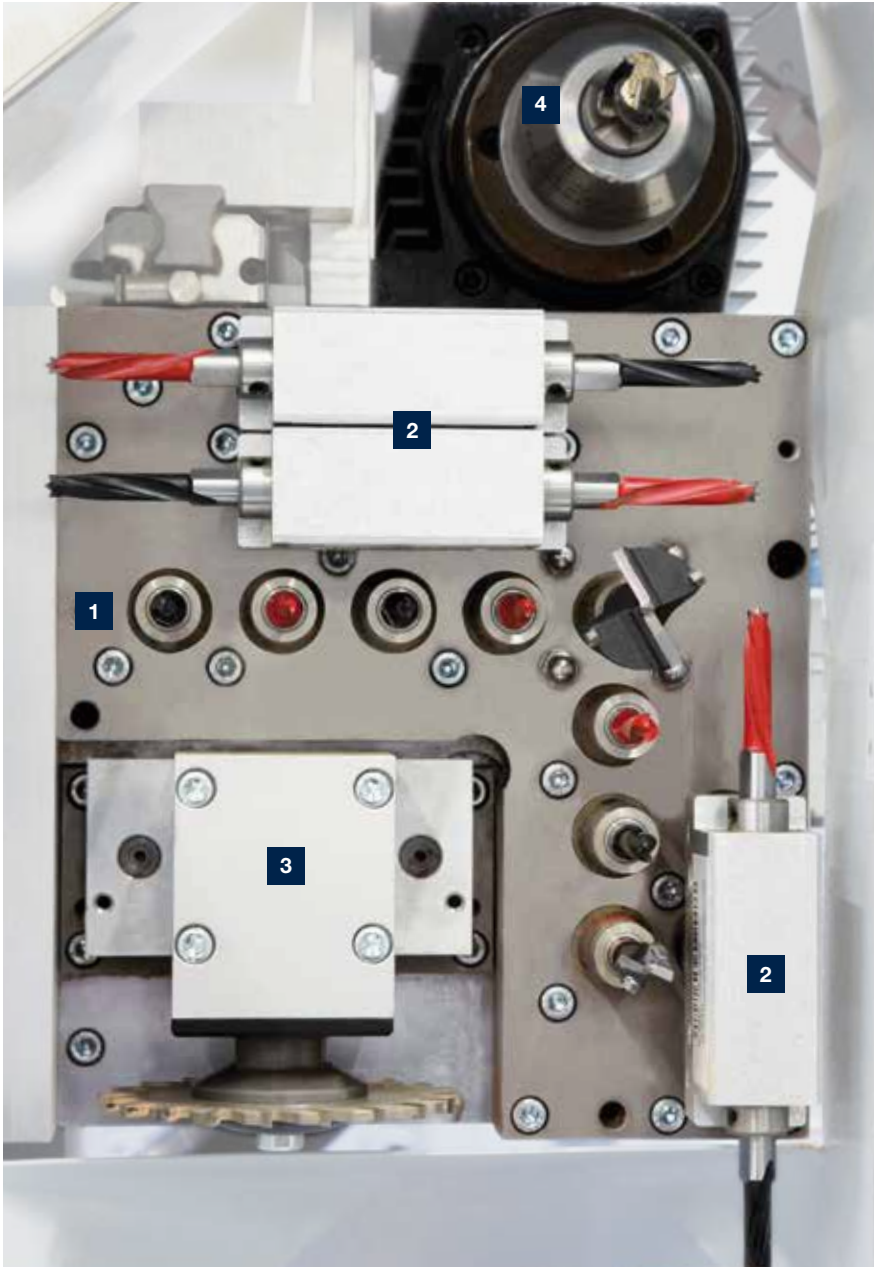

STANDARD

- 1** 8 vertical drilling spindles, incl. quick-change drilling system

OPTIONS

- 2** Option – horizontal drilling
 - 4 High-speed drilling spindles in X-direction
 - 2 High-speed drilling spindles in Y-direction
- 3** Option – grooving
 - Grooving saw in X-direction, Ø 100 mm
- 4** Option – routing
 - Router motor with hydraulic quick change system, 5 kW ETP 25

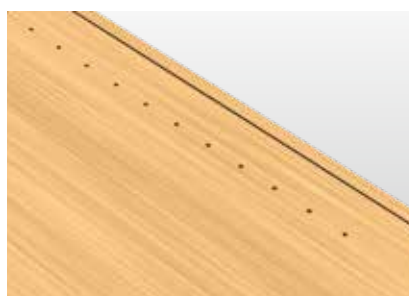
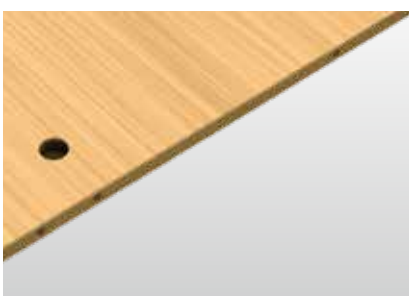

Equipment packages for V13

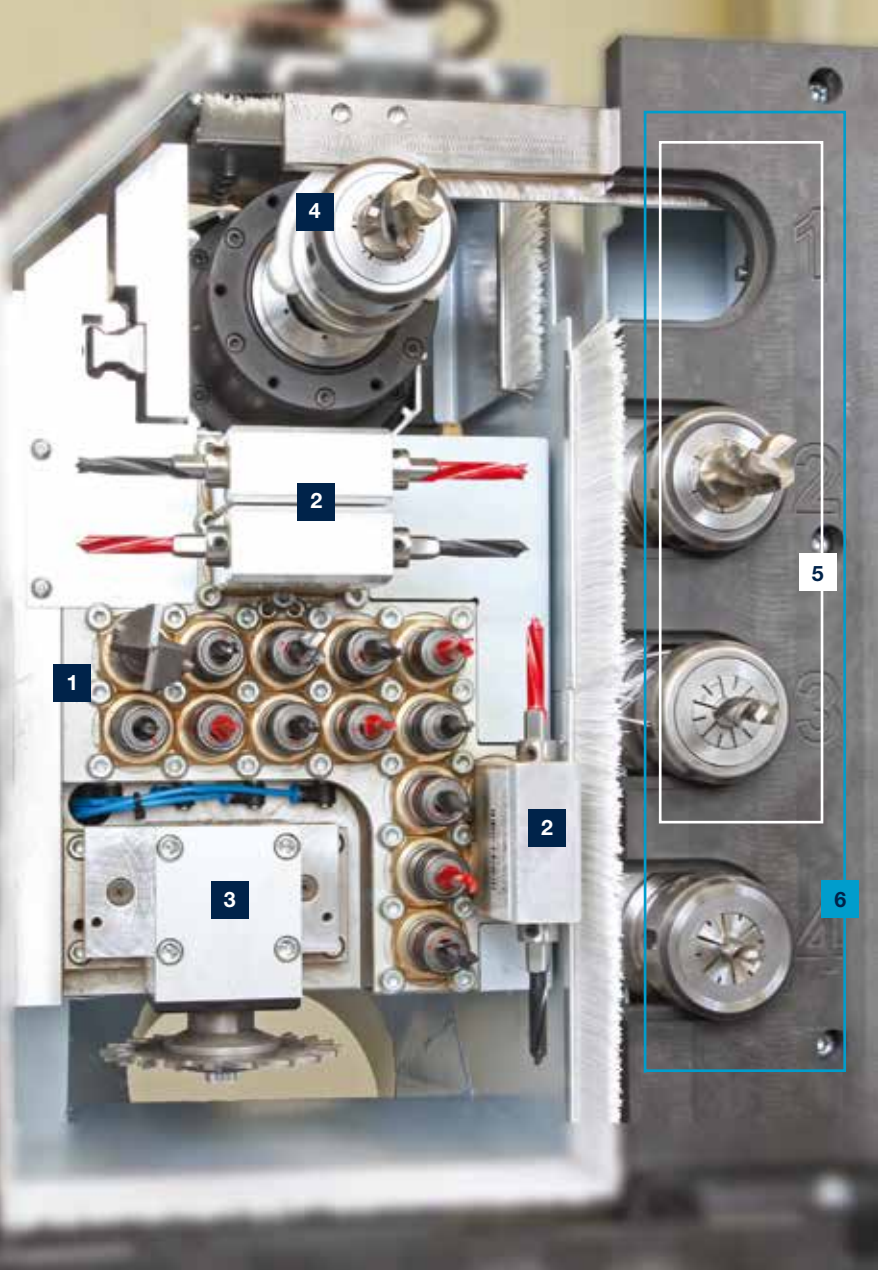

STANDARD

- 1** 13 vertical High-speed drilling spindles, incl. quick change drilling system

OPTIONS

- 2** Option – horizontal drilling
 - 4 High-speed drilling spindles in X-direction
 - 2 High-speed drilling spindles in Y-direction

- 3** Option – grooving
 - Grooving saw in X-Direction, Ø 100 mm

- 4** Option – routing
 - Tool changing spindle 5 kW HSK 63

- Option – tool changer**
 - Automatic tool change magazine with 3 places. Extension of the tool change magazine by one place.

- 5** Option – 3 places

- 6** Option – 4 places



All inclusive – Hardware

TOP EQUIPMENT RIGHT FROM THE BEGINNING: Already in the standard elementary technologies are included, which ensure sustainable highest processing quality.



powerControl with powerTouch

- 21,5" Full-HD multitouch display with wide screen 16:9
- Front USB interface
- Ethernet connection 10/100 Mbit



powerTouch is the latest operating philosophy of the HOMAG Group: simple, uniform, ergonomical, evolutionary. The innovative touchscreen operating concept unites design and function to create a totally new control generation.



Automatic workpiece thickness adjustment

- Automatic adjustment of the counter block to the material thickness according to the data preselected by the operator in woodWOP

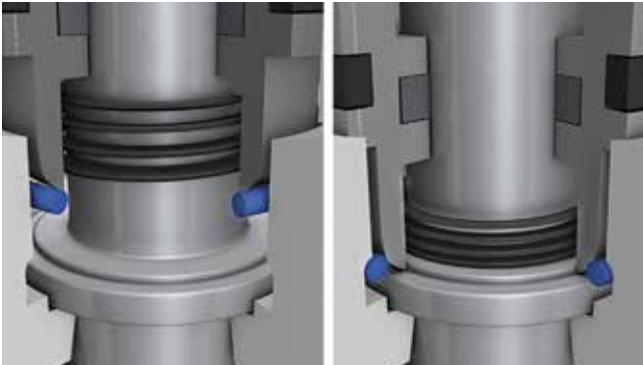

Automatic spindle clamping

- Patented system for exact drilling depth at any time with different materials
- Lasting assurance of drilling quality



Drill quick-change system

- The patented system ensures easy installation or change of drilling bits. Your easy way to save time!



Workpiece load- and workpiece removal area

- Mechanical support via roller conveyor in the loading- and removal area of the machine

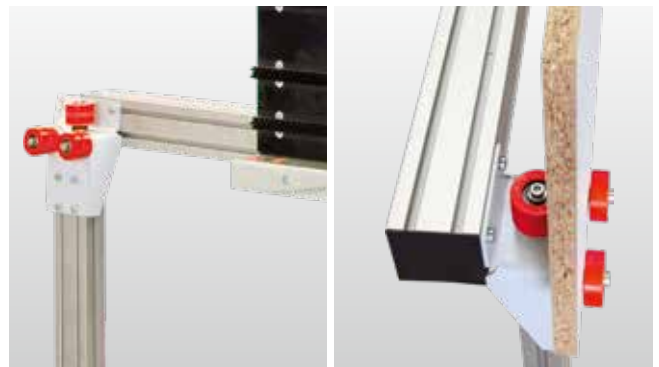

Working length extension

- Extension of the working length from 2500 to 3050 mm incl. roller conveyor



Workpiece clamping device

- Easy adjustment of the clamping device (manually) to the workpiece thickness (clamping device stroke 10 mm). For differences in the workpiece thickness of up to 10 mm it is not necessary to manually adjust the clamping device.

All inclusive – Software

WITH THIS SOFTWARE PACKAGE YOU ARE »READY TO RACE«. You will receive one of the most established CNC-programming systems, the woodWOP software, which has proven itself by more than 30.000 installations worldwide.

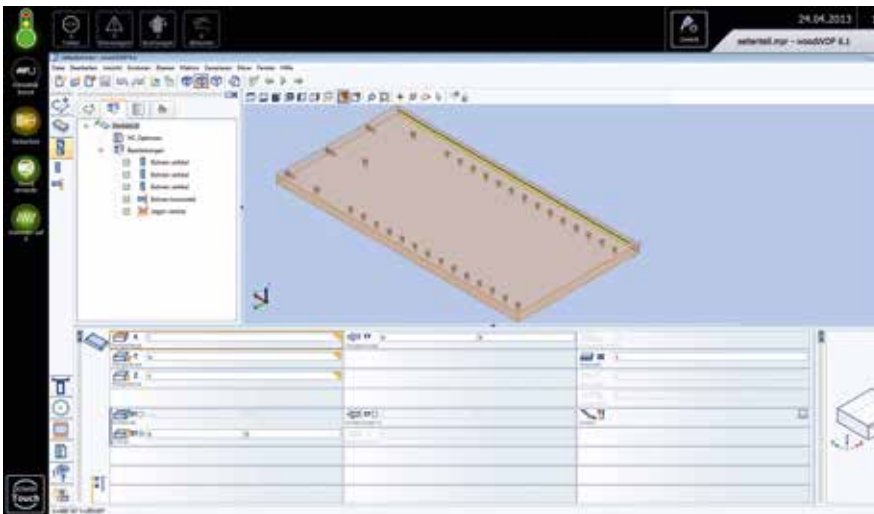

Please use our website!

Worldwide largest forum for woodWOP:
forum.homag.com

woodWOP | License Machine

- Fast and intuitive operation thanks to simple, direct navigation
- Select from a choice of variables for flexible variable programming
- Quickly create individual subprograms
- Increased programming security through 3D images of workpieces, processing and clamping equipment.

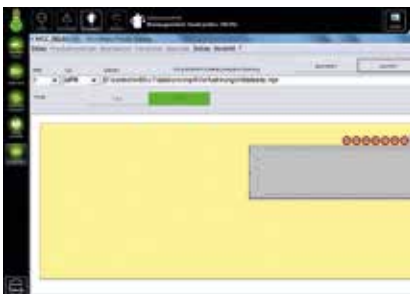

MCC

- Simple control of main machine functions through soft keys
- Graphical configuration
- Automatic mirroring of workpieces



woodWOP DXF Basic

- Interface for CAD-Data Import
- Basis to generate woodWOP programs



Machine data acquisition MMR Basic

- Record quantities and actual operating times on the machine
- Integrated maintenance instructions for optimum time and quantity-based planning, as well as performing maintenance

Option – Software

WITH ADDITIONAL SOFTWARE MODULES you can further optimize your processes.

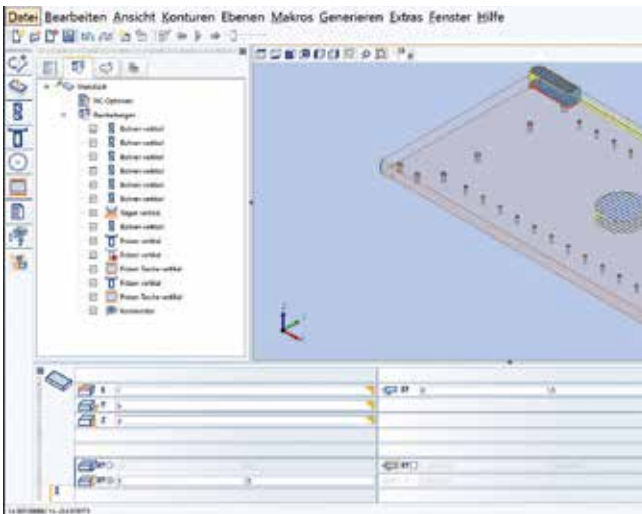

woodWOP | License Office

- Single user or network licenses available
- Incl. DXF-Import CAD-Plugin to create your own CAD drawings on the machine and at the workplace

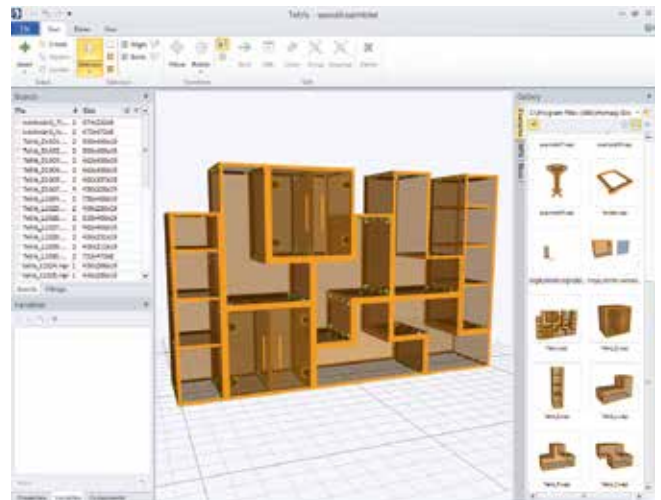

woodAssembler

- To visualize woodWOP programs (MPR) in 3D
- Enables the construction of individual workpieces to finished objects



3D CNC-Simulator

- Simulates the processing acc. to the order set in the NC program
- Allows time calculation

ADDITIONAL SOFTWARE

1. woodWOP Office
2. 3D CNC-Simulator
3. woodAssembler



Package

Option – Plausibility Check

BENEFIT FROM ADDITIONAL SAFEGUARDING OF PROCESSES

Control of the workpiece by sensor technology in X- and Y-direction. Comparison with the values in the database. If the defined tolerance value is exceeded, the current process stops. At the same time the operator receives a message to correct the workpiece. This way you remain on the safe side.

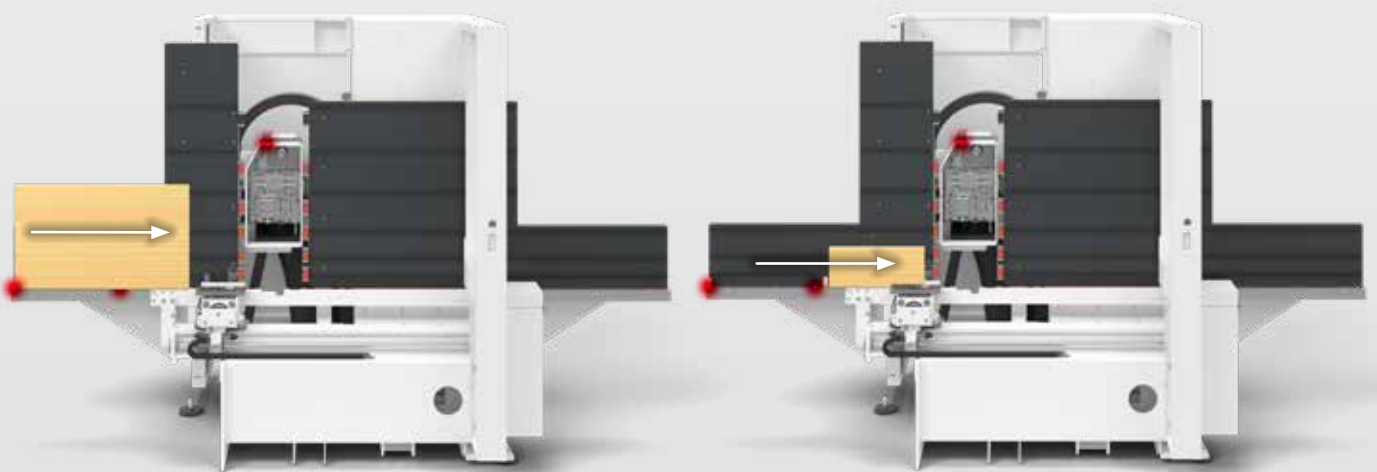

Step 1:

- Positioning the workpiece

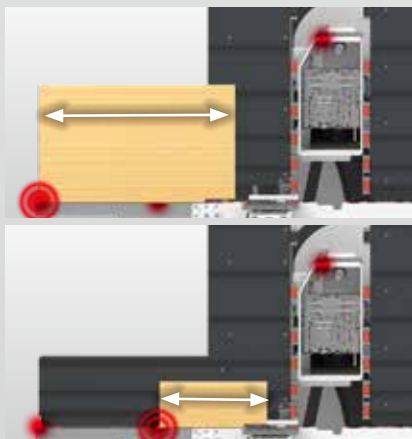

Step 2:

- Control of the workpiece by sensor technology in X-direction. Depending on the workpiece dimensions the shortest distance to the next sensor is selected.

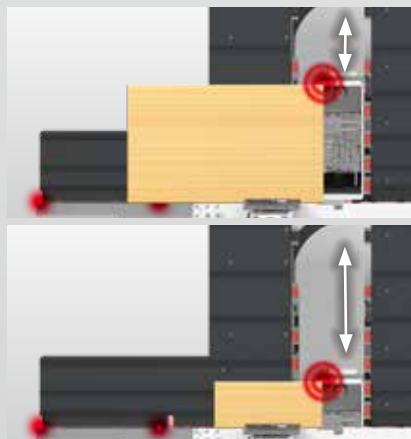

Step 3:

- Control of the workpiece by sensor technology in Y-direction



Step 4:

- Balancing the determined values with the program data:
- Tolerance of values < 5 mm – Program is continued.
- Tolerance of values > 5 mm – Program is stopped, advice to the operator to carry out the corrections.

Option – Length-depending processing in X-direction

AUTOMATIC ADJUSTMENT OF DRILLINGS DEPENDING ON WORKPIECE DIMENSIONS

After the workpiece has been released for processing its length is measured accurately by a measuring run. Dimension-depending drillings are then corrected automatically by possibly determined tolerances. You save time and gain quality.

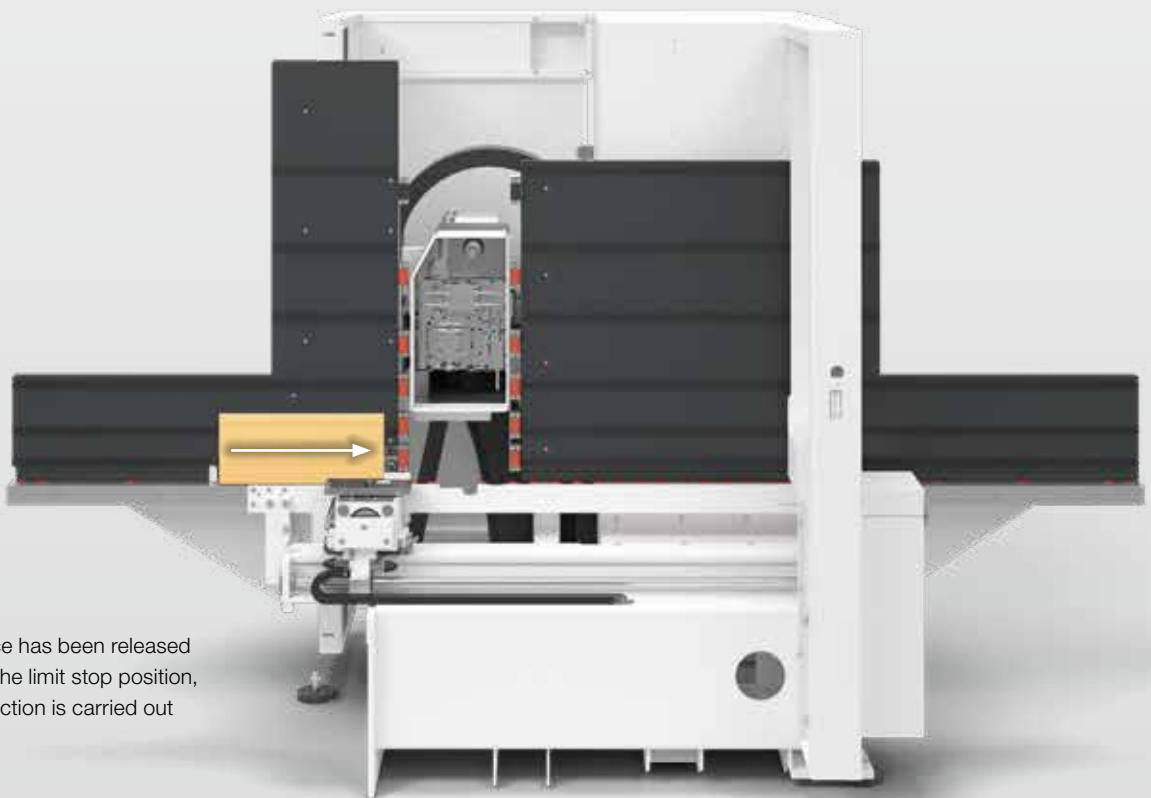

A

- After the workpiece has been released for processing at the limit stop position, a test run in X-direction is carried out (value 1).



B

- Determination of exact workpiece length (value 2).

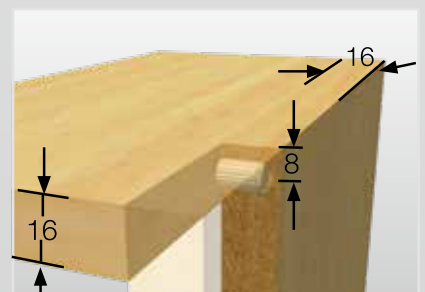

C

- Drills depending on dimensions are then automatically corrected by possibly determined tolerances.



1,200
service employees around the world



5,000
Customers in training / year

> 90%
less on-site-services through successful remote diagnosis

> 150,000
machines, all electronically documented in 28 different languages – in eParts

HOMAG LifeCycleServices

The sale of our machines comes with all-in optimum service backup and individual advice. We support you with service innovations and products which are especially tailored to your requirements. With short response times and fast

customer solutions we guarantee consistently high availability and economical production – over the entire life cycle of your machine.



Remote Service

- Hotline support via remote diagnosis regarding control, mechanics and process technology. Thus the on-site service can be reduced by more than 90 %!
- Mobile applications such as ServiceBoard reduce the costs through fast help in case of troubles by mobile live video diagnosis, online service message and the online spare parts shop eParts



Spare Parts Service

- Identify, request and order spare parts around the clock via www.eParts.de
- Local availability of parts offered by our sales and service companies as well as sales and service partners all over the world
- Reduction of downtimes through defined spare parts and wear parts kits



Field Service

- Increased machine availability and product quality by certified service staff
- Regular checks through maintenance / inspection guarantee the highest quality of your products
- We offer you the highest availability of technicians in order to reduce downtimes in case of unpredictable troubles

Technical Data



Dimensions in mm

* A corresponding safety distance must be maintained in the in and outfeed direction! (See documentation)

TECHNICAL DATA			
Workpiece dimensions max.	L x W x T	mm	2500 x 850 x 60 / optional 3050
Workpiece dimensions min.	L x W x T	mm	200 x 70 x 12
Vector speed		m/min	(X - Y) 50 - (Z) 15
Compressed air required		bar	7
Compressed air connection		inch	R 1/2
Dust extraction port		mm	Ø 160
Dust extraction volume		m ³ /h	min. 2170
Electrical power – total connection load		kW	11,5
Total machine weight		kg	approx. 1580

HOMAG Group AG

info@homag.com

www.homag.com



YOUR SOLUTION