

Sizing and Edge Banding Machines Optimat KFL 525 and KFL 526

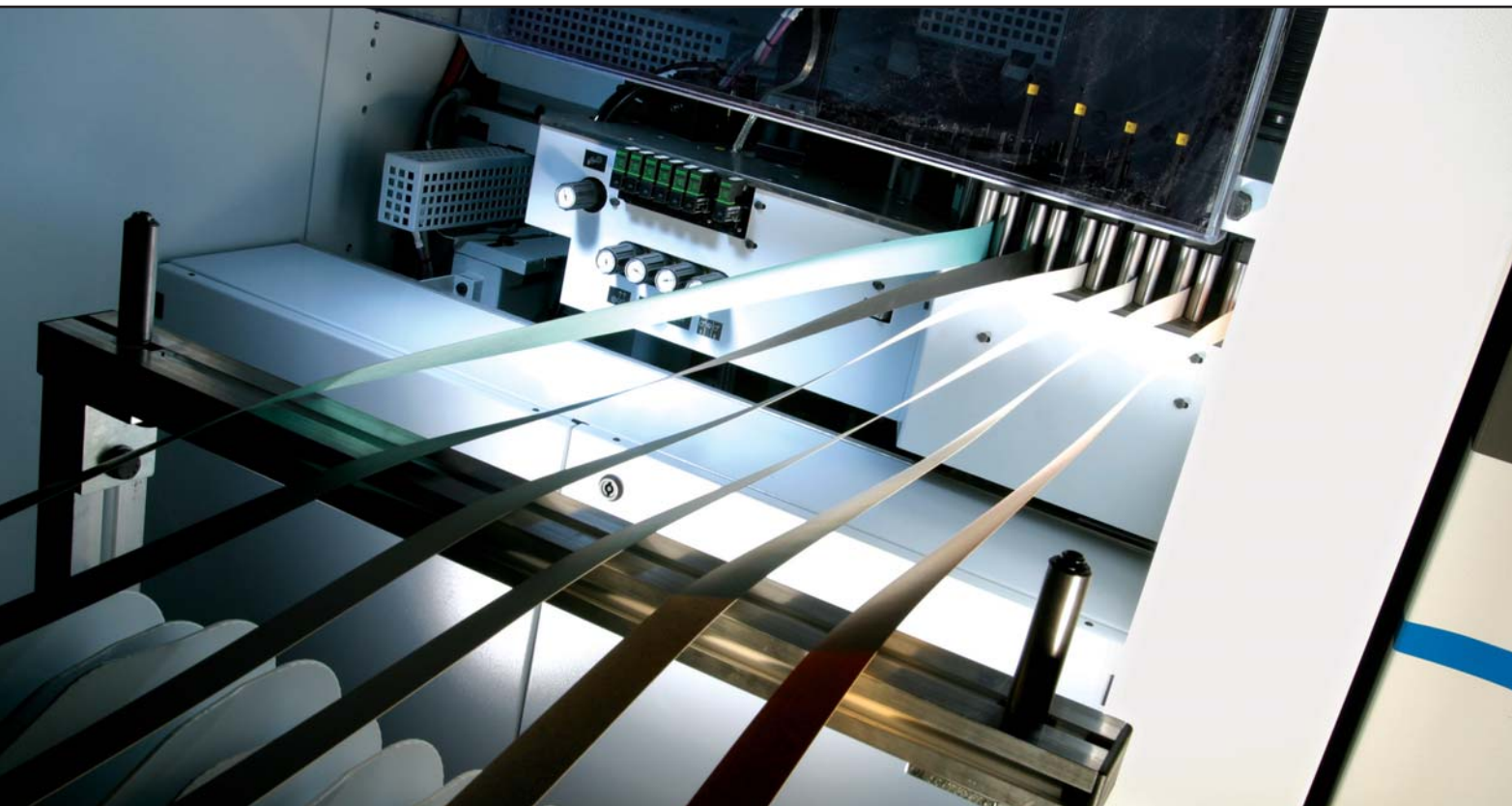

Optimat | profi line | power line







Optimat KFL 526

The New Optimat Series: Unrivalled benefits

- 20% greater output coupled with 10% cost savings
- Output up to 30 cycles/min.
- Flexibility through a wide choice of units
- High degree of automation
- Even better processing quality
- **I-tools for improved processing quality and reduced extraction costs**

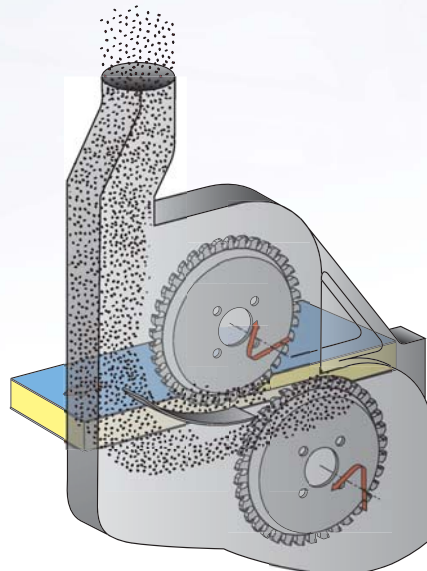
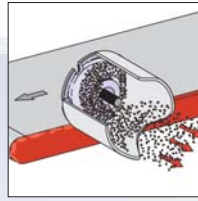
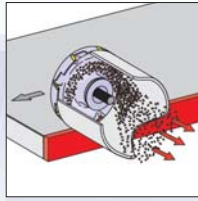
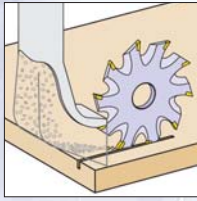
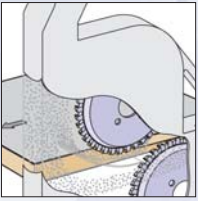

High tech need not cost more



The new Optimat series

For the very first time, no-compromise high-performance engineering excellence handed down directly from industry has been made accessible at an affordable price. The new Optimat series offers even greater performance and important further detail improvements. The basic machine of both Optimat models is identical, encompassing sizing, trimming and gluing functions. The new closed design offers not only cost advantages but improved quality, safety and noise conditions too.

Benefits of the basic machine

- Lower-cost entry due to modular construction
- Optimum adjustment to customer requirements due to a choice of machine lengths allowing equipment with different units
- High production quality coupled with a long service life
- Closed, highly rigid framework structure - resulting in vibration-free operation and improved appearance of the trimmed surface
- Transport chain offering long service life due to large ball bearing diameter for smoother running and improved workpiece quality
- Continuous machine enclosure for increased safety and improved noise protection

Optimum workpiece processing

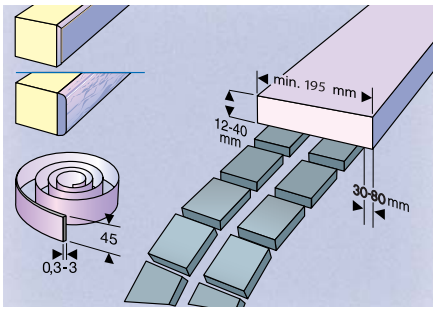

Transverse processing dogs

Workpieces requiring transverse processing are simply rested against the infinitely adjustable dogs (for longitudinal processing, the dogs are lowered and run with the transport chain). This ensures that the material is guided reliably at precisely the right angle towards the machine.



Transverse processing dogs

Lower workpiece width of the KFL 525 series

The two chain tracks can be moved so close together that workpieces from as narrow as 195 mm can be processed.

Improved workpiece overhang adjustment

The workpiece overhang over the chain track can be manually or automatically adjusted from 30 to 80 mm, allowing the manufacture of grooves at even greater distances from the edge of the workpiece.

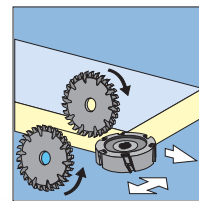

Hogging and trimming

The new Optimat series features a compact, space-saving design. The basic machine is fitted with a high-performance compact double hogger (KD 10 with 2 motors in the Optimat KFL 525, KD 11 with 3 motors in the Optimat KFL 526) which ensures splinter-free panel sizing. **Now also with the I-System.**



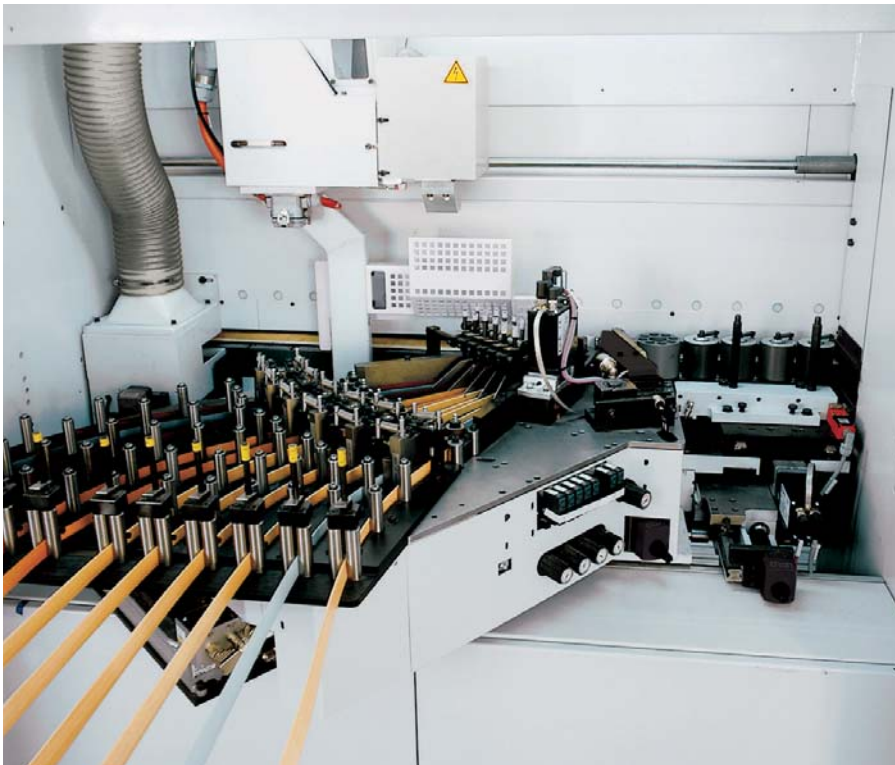

Gluing section Optimat KFL 525 / KFL 526

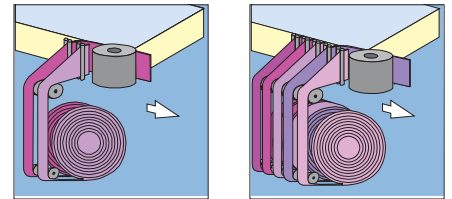

Gluing

The A3 gluing unit permits the use of widely differing edging materials without the need for resetting work. The relevant decentral control unit is linked to the main control system by fibre optic cable in order to avoid electro-magnetic interference. The benefits in detail:

- 2 – 24-slot magazine
- Minimum possible edging material length: 100 mm; This means that no excess edging material lengths are required even for narrow parts such as drawer fronts (material savings)
- Edging material savings also due to minimal lengthways edge overhang. This can be partially removed already while trimming during the first pass, so eliminating the need for the snipping process (option)
- Outstanding gluing quality when using standard hot melt glues - PU gluing is also optionally possible
- Processing of all commonly used edging materials types - veneers, PVC, melamine, ABS either off the coil or with manual fixed length material feed (optionally with fixed length magazine)



Standard trimming unit SF 20. Grooving and rebating

Facility for equipment with one trimming unit in front and two trimming units behind the gluing section.

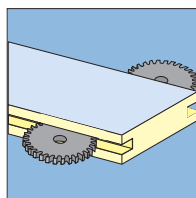

Wide range of finish processing and finish units to choose from

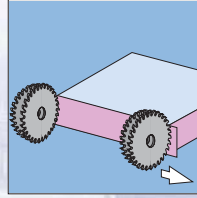

Snipping devices

A range of compact, multi-functional and hardwearing units are available for snipping overhanging edges.

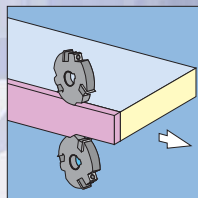
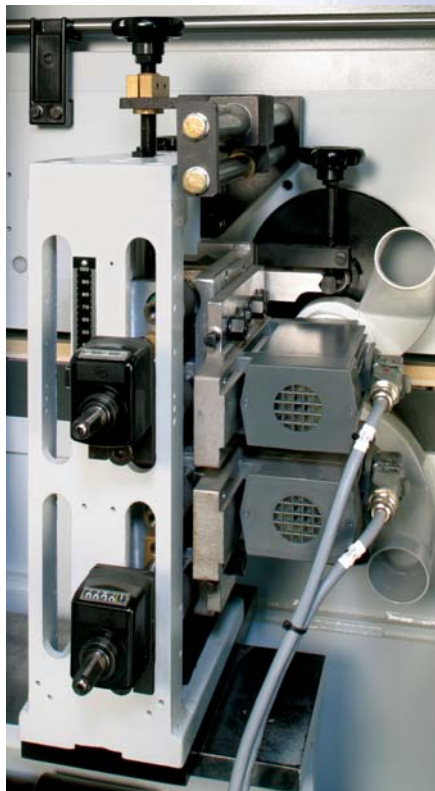

Rough trimming unit

For rough trimming the upper and lower edge overhang.

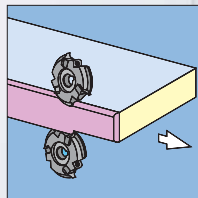

Trimming unit

For trimming the chamfer or radius.

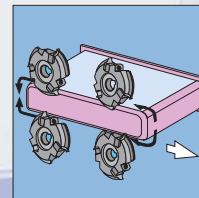

Profile trimming

There is a wide selection of different profile trimming units available. The FK 21, for instance, is a path-controlled high-performance unit with separate decentral control for feed rates of over 30 m/min. (Optionally available is also the FK 23 with an automatic 8-slot tool changer to cut down on resetting times). Chamfer adjustment for processing one radius and one chamfer takes place automatically without the need for a tool change. The FK 21 is equipped as standard with I-tools.



Belt sanding unit KS 10

With oscillating device and pneumatic belt cleaning jet to enhance the service life of sanding belts. Optionally with automatic adjustment for different edging thicknesses and torn belt monitoring.

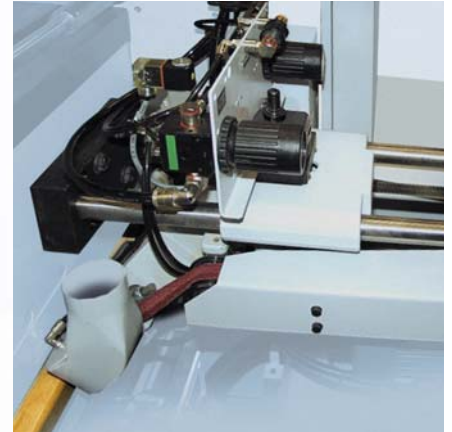
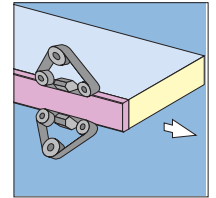
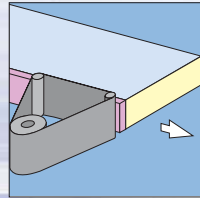

Chamfer/radius sanding unit PS 41/PS 42

For sanding chamfers and radii from above and below on veneer and solid wood edges.

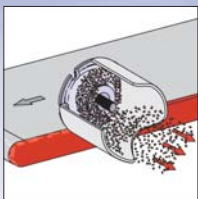
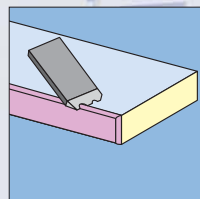
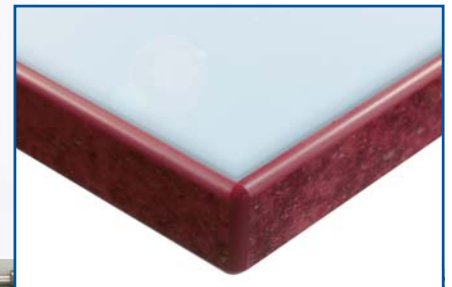

I-System

I-tools deflect the chips away from the tool cutting edge and dispose of them at a pick-up rate of over 97% even at low extraction speeds. The I-system markedly improves not only process reliability, the working environment and productivity, but also reduces energy costs used for extraction.

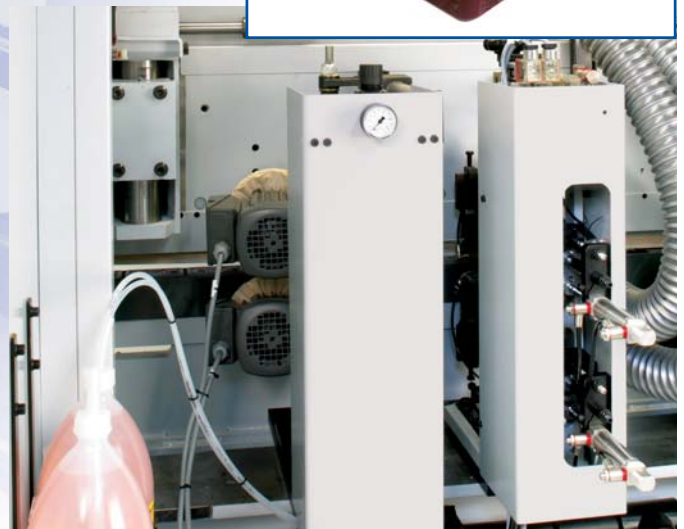

Finish processing FA 11

Comprising a glue joint scraping unit, cleaning agent application and buffing for removing glue residues above and below on PVC edges.

Tailor-made plant concepts

Extension as the need arises

The machines of the new Optimat series are designed as a first machine (Optimat KFL 525 for longitudinal throughfeed) and second machine

(Optimat KFL 526 for longitudinal and transverse throughfeed). The Optimat KFL 526 can also be equipped without problems to permit a first and second workpiece pass.

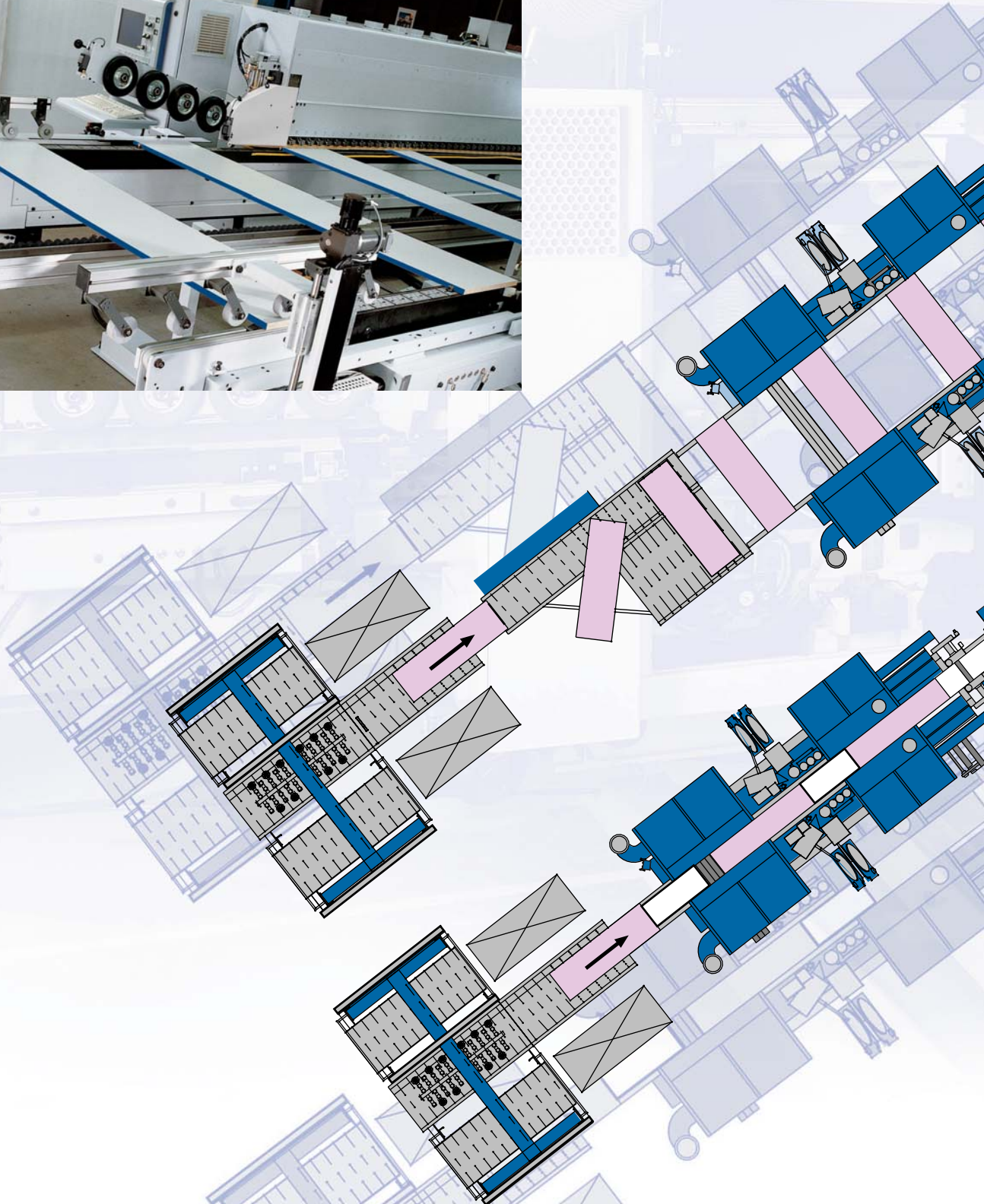

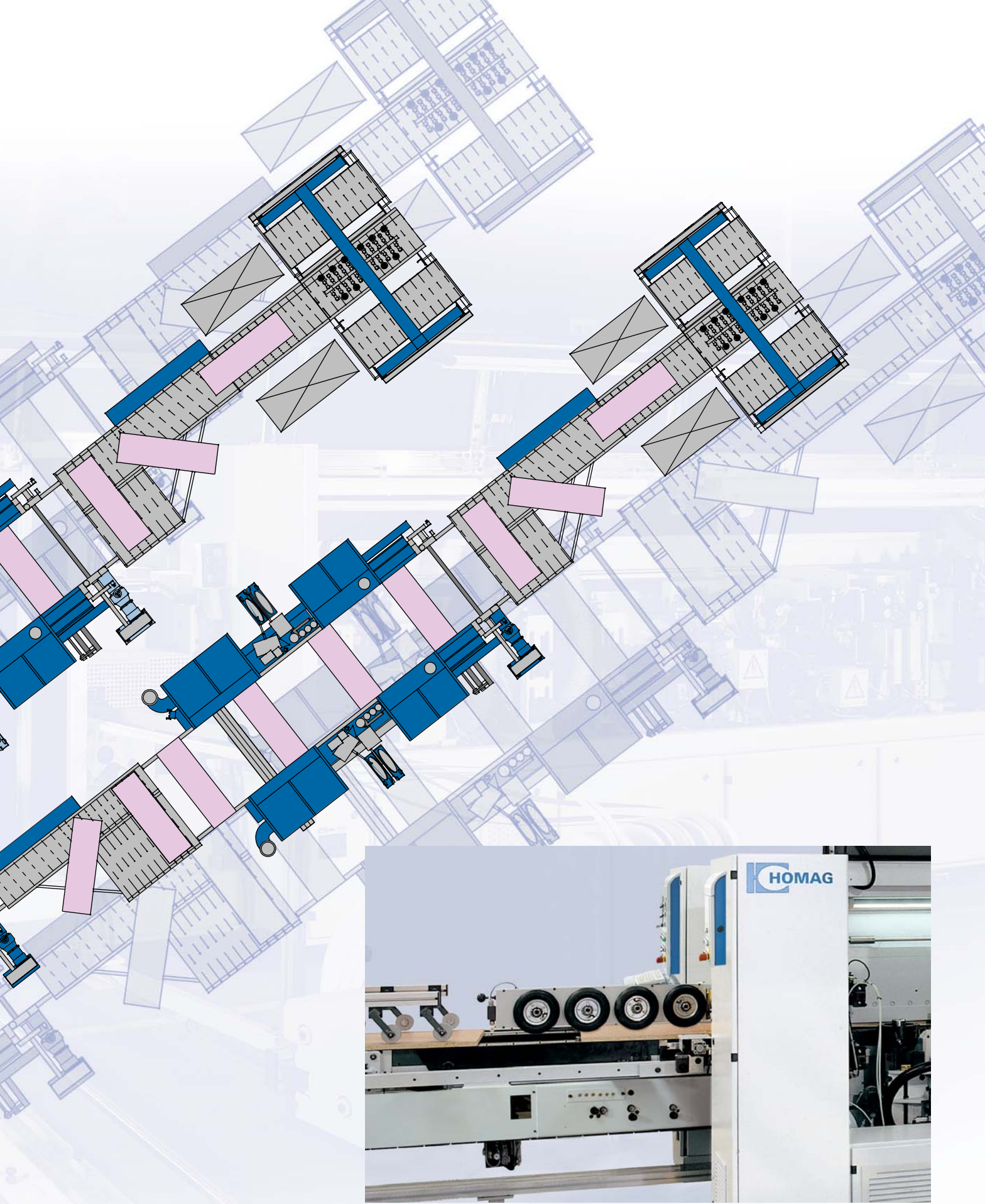

Capacity is the deciding factor

If you begin, for example, with an Optimat KFL 526 as a single machine, and your capacity requirement then increases, this machine can be simply combined with an Optimat KFL 525 and extended to create a complete machine line.

When you invest in the new Optimat series, you are acquiring reliable, leading Homag technology to the very highest standard of quality. And all at an amazing cost-to-performance ratio within a gratifyingly short delivery and installation period.

The control system – fast, reliable and easy-to-operate

Outstanding economy

In conjunction with the wide range of available units with automation capacity, almost all resetting processes can be controlled centrally from the control desk, eliminating the issue of resetting times and paving the way for the economical production of even minimal batch sizes.

Operating convenience

Programming and operating an edge banding machine has never been so easy and convenient. The new control system with flat colour monitor and dust-proof PC keyboard offers maximum operating ease is based on the internationally established Windows standard, familiar to everyone with even minimal PC skills. The simple, self-explanatory user prompting system allows familiar thought processes and procedures to be transposed directly into the control inputs required for workpiece processing. Supplementary transport systems can be integrated without problems into the existing control system.

Remote diagnosis included

Standstill periods can be avoided by rapid response to direct error messages on screen (such as "enclosure open"). And should it ever prove impossible to solve a problem internally, the Homag remote diagnostic system can generally save the need for calling out a service technician.

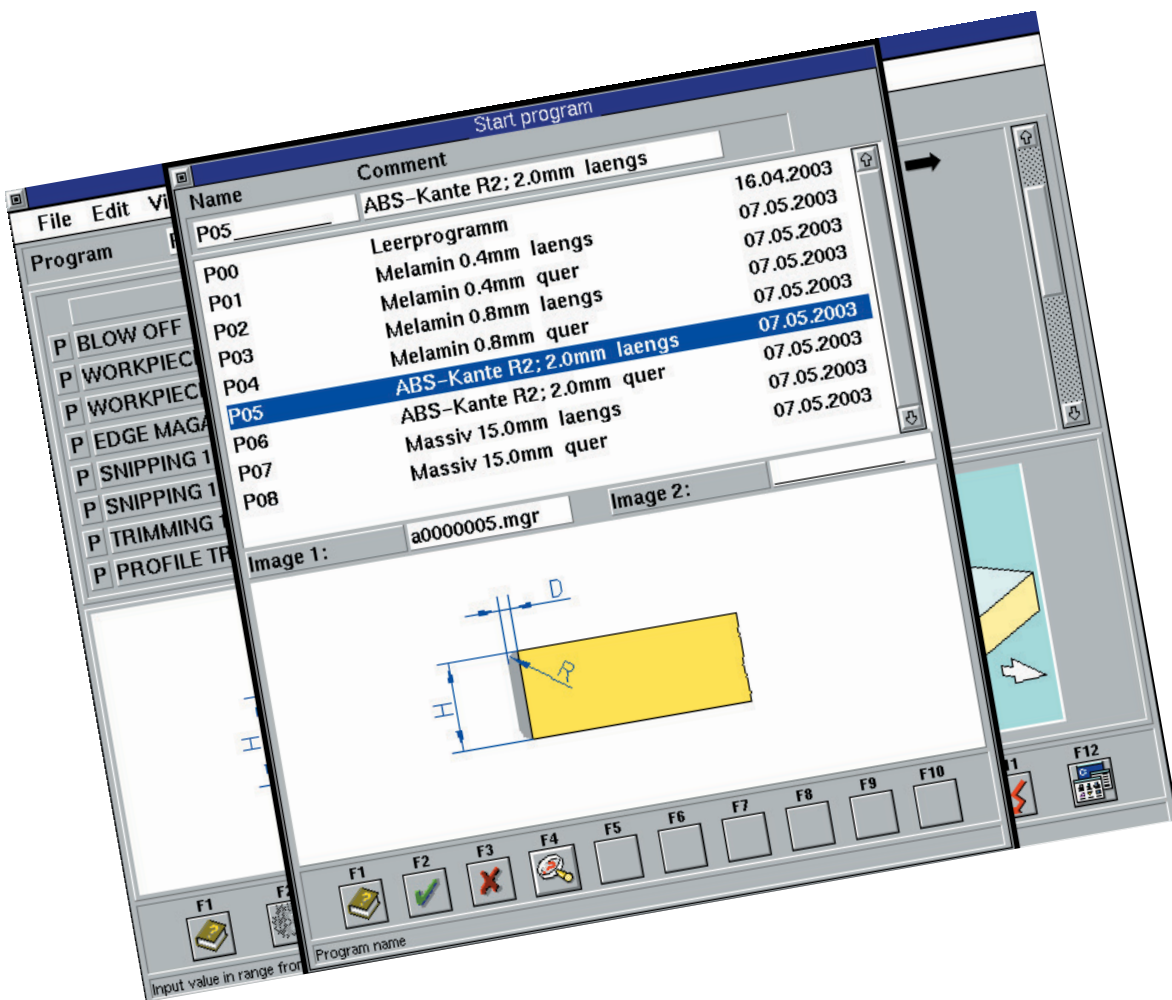

HOMAG

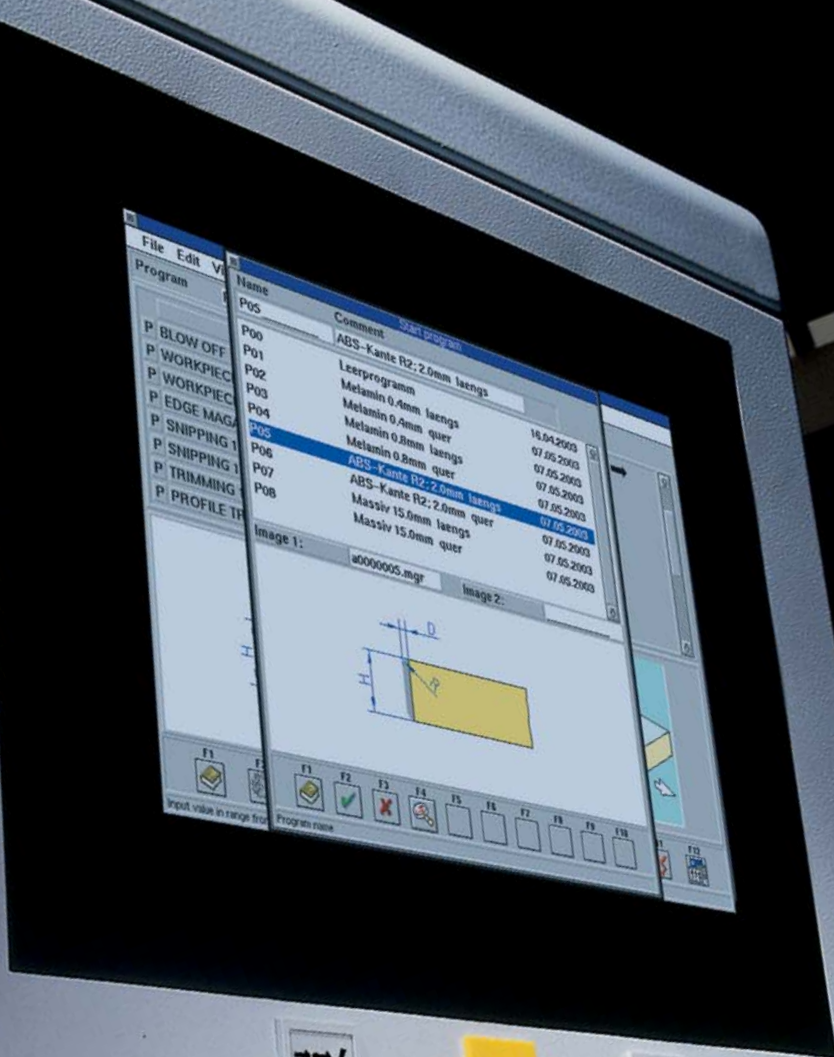

Program	Name	Comment	Start program
P00	ABS-Kante R2: 2.0mm laengs		
P01	Leerprogramm		
P02	Melamin 0.4mm laengs		16.04.2003
P03	Melamin 0.4mm quer		07.05.2003
P04	Melamin 0.8mm laengs		07.05.2003
P05	Melamin 0.8mm quer		07.05.2003
P06	ABS-Kante R2: 2.0mm laengs		07.05.2003
P07	ABS-Kante R2: 2.0mm quer		07.05.2003
P08	Massiv 15.0mm laengs		07.05.2003
	Massiv 15.0mm quer		07.05.2003

Control panel section containing a power button with a lightning bolt symbol, a large red emergency stop button, and a yellow button with a square symbol.

Control panel section containing a large black rotary knob, a power switch, and a silver key switch.



It pays to be a Homag customer



Homag is everywhere

A well-developed servicing, sales and dealer network means even greater proximity, rapid response and improved customer support – all over the world.

Practically-oriented training

Although Homag products are designed for outstanding operating simplicity, thorough training does help cut down on commissioning times, reduces scrap from trial and error, helps develop the skills of the operator and generally improves efficiency.

With this aim in mind, customer training courses are held in a number of languages in our own training centre.

Careful maintenance

Scheduled, correctly performed maintenance helps reduce costs and increase the productivity and service life of plant and machinery.

Identical parts, simple handling

A large number of the parts, control elements and assemblies used in Homag Group plants and machines are identical. The wide-ranging benefits of this policy include simplified operation, lower costs, streamlining of spare parts management and also faster maintenance and servicing - to name only a few.

Remote diagnosis worldwide

All NC machines are fitted in the factory with a modem to allow remote diagnosis anywhere around the globe. A search for possible faults is performed from the Homag Service Centre. Once localized, they are narrowed and often already solved over the phone.

Specifications Optimat KFL 525/KFL 526

Optimat KFL 525 (Line version machine I)

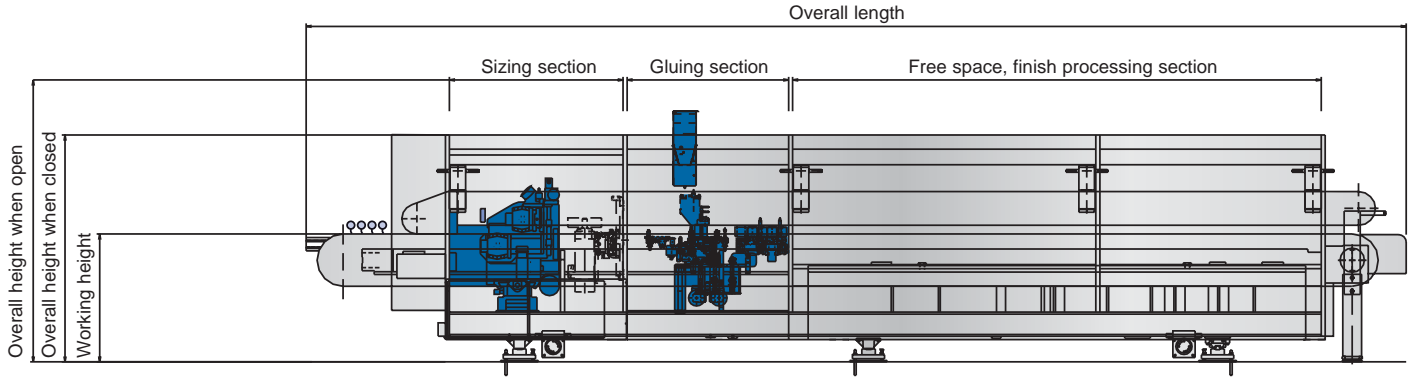

Optimat KFL 526 (Individual machine / Line version machine II)

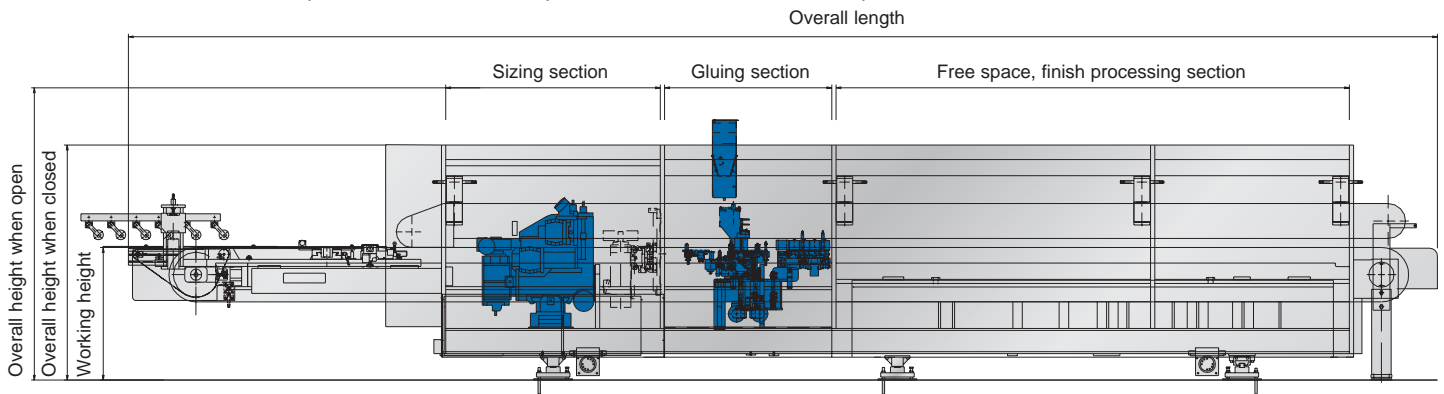

Set-up dimensions	Optimat											
	KFL 525						KFL 526					
Overall height when open [mm]	2300 (90,551")						2300 (90,551")					
Overall height when closed [mm]	1740 (68,504")						1740 (68,504")					
Working height [mm]	950 (37,401)						950 (37,401)					
Length	05	06	07	08	09	10	05	06	07	08	09	10
Extraction output [m³/h]	je nach Bestückung						je nach Bestückung					
Electrical connected load [KW]	ab 20 (26,820 HP)						ab 25 (32,526 HP)					
Free space [mm]	2050 (80,708")	3050 (120,472")	3885 (152,952")	4885 (192,322")	-	-	1800 (70,866")	2800 (110,236")	3635 (143,110")	4635 (182,480")	5635 (224,850")	6635 (261,220")
Line version machine I	6650 (261,810")	7650 (301,180")	8650 (340,550")	9650 (379,920")	-	-	-	-	-	-	-	-
Line version machine II	-	-	-	-	-	-	7880 (310,235")	8880 (349,605")	9880 (388,975")	10880 (428,345")	11880 (467,715")	12880 (507,085")
Solo machine	-	-	-	-	-	-	7650 (301,180")	8650 (340,550")	9650 (379,920")	10650 (419,290")	11650 (458,660")	12650 (498,030")

Specification and photo details without commitment. We reserve the express right to make changes in the interests of progress.



A member of the Homag Group



Homag Holzbearbeitungssysteme AG

Homagstraße 3-5
72296 SCHOPFLOCH
DEUTSCHLAND

Tel.: +49 (74 43) 13-0
Fax: +49 (74 43) 13 23 00
E-Mail: info@homag.de
Internet: www.homag.com

