

# PEGASO 630 1K 2R

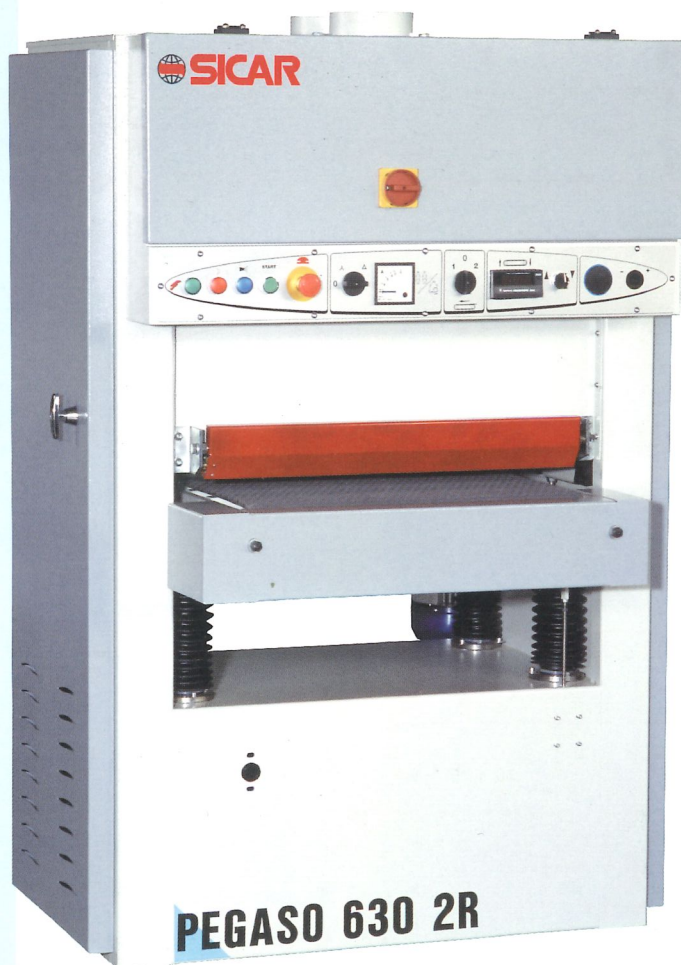

Calibro levigatrice  
Calibrating and sanding machine  
Kalibrier-und schleifmaschine  
Ponceuse calibreuse à bande  
Calibro-lijadoras



**SICAR**  
**AUTOMAT**

Calibro Levigatrici Calibrating and Sanding Machines Kalibrier- und Schleifmaschinen Ponceuse-Calibreuse à Bande Calibro-Lijadoras		1K	2R
Larghezza utile di lavoro Useful working width Arbeitsnutzbreite Largeur utile de travail Anchura útil de trabajo	mm	630	630
Altezza max. di lavoro Max. working height Max. Arbeitshöhe Hauteur max. de travail Altura max. de trabajo	mm	160	160
Altezza min. di lavoro Min. working height Min. Arbeitshöhe Hauteur min. de travail Altura min. de trabajo	mm	3	3
Lunghezza minima di lavoro Min. working length Min. Arbeitslänge Longueur min. de travail Longitud mínima de trabajo	mm	460	240
Larghezza nastri abrasivi Width of sanding belts Sandbandbreite Largeur de bandes abrasives Anchura de las lijas	mm	630	630
Sviluppo nastri abrasivi Development of sanding belts Sandbandentwicklung Développement de bandes abrasives Desarrollo de las lijas	mm	1525	1525
<b>Accessori a richiesta Optional accessories Zubehör auf verlangen Accessories en option Accesorios opcionales</b>		<b>1K</b>	<b>2R</b>
Potenza motore principale Main motor power Main bewegungs energie Puissance moteur principal Potencia del motor principal	Hp 7,5 (Kw 5,5) Hp 10 (Kw 7,5) Hp 12,5 (Kw 9) Hp 15 (Kw 11)	● ● ● —	— ● ● ●
Avviamento stella-triangolo Star-Delta starter Anlasser ster dreieck Demarreur étoile-triangle Arranque estrella-triangulo		●	—
Sollevamento motorizzato del piano con indicatore numerico Motorised rising of the table with numerical display Motorisierte erhebung des planes mit nummer indikator Soulevement motorise de la table avec indicateur numerique Suvida motorizada de la mesa con indicador numerico		●	—
Rullo calibratore in gomma 90 Sh Rubber calibrating roller 90 Sh Kalibrierter walze tragantgummi 90 Sh Rouleau calibre en caoutchouc 90 Sh Rulo calibrador en goma 90 Sh		●	—
Primo rullo in gomma 1st rubber roller Erster tragantgummi walze Premier rouleau en caoutchouc Primer rulo en goma	90 Sh 65 Sh 45 Sh	— — —	● ● ●
Secondo rullo in acciaio scanalato elicoidalmente 2nd steel roller helicoidal slotted Zweiter walze um stahl mit schraubenförmiger aushöhlung Deuxieme rouleau en acier crané helicoidal Segundo rulo en acero acanalado elicoidalmente		—	●
Secondo rullo in gomma 2nd rubber roller Zweiter walze um tragantgummi Deuxieme rouleau en caoutchouc Segundo rulo en goma	90 Sh 65 Sh	— —	● ●
Normativa CSA CSA standard CSA standard Normes CSA Normatiba CSA		●	●

Calibro Levigatrici Calibrating and Sanding Machines Kalibrier- und Schleifmaschinen Ponceuse-Calibreuse à Bande Calibro-Lijadoras		1K	2R
Velocità nastri abrasivi Speed of sanding belts Sandbandgeschwindigkeit Vitesse de bandes abrasives Velocidad de las lijas	m/min.	11	11
Diametro rullo standard Diameter of standard roller Standardrollerdurchmesser Diamètre du rouleau standard Diametro del rodillo standard	mm	∅ 150	∅ 150
Durezza rullo standard Hardness of standard roller Standardrollen Härte Dureté du rouleau standard Durezza del rodillo standard	Acciaio scanalato Slotted steel Stahl mit aushöhlung Acier crané Acero acanalado	1° Acciaio scanalato - 2° 45 Sh 1° Slotted steel - 2° 45 Sh 1° Stahl mit aushöhlung - 2° 45 Sh 1° Acier crané - 2° 45 Sh 1° Acero acanalado - 2° 45 Sh	
Velocità di avanzamento tappeto Speed of feed carper Geschwindigkeit des vorschub Teppichs Vitesse de d'avance tapis Velocidad de las lijas	m/1'	4,5 ÷ 9	4,5 ÷ 9
Potenza motore nastro Power of belt motor Scheifmotorstärke Puissance moteur bande Potencia motor lija	HP Kw	5,5 4	7,5 5,5
Potenza motore avanzamento Feed power motor Vorschubmotorstärke Puissance moteur d'avance Potencia motor de avance	HP Kw	0,5 ÷ 0,75 0,33 ÷ 0,55	0,5 ÷ 0,75 0,33 ÷ 0,55
Pressione di esercizio Air pressure Erforderlicher Arbeitsdruck Pression de service Presión	Atm	6	6
Consumo aria compressa (senza soffiatori) Compressed air consumption (without blowers) Luftverbrauch (ohne Bläser) Consommation d'air comprimé (sans souffleurs) Consumo de aire comprimido (sin sopladores)	nl/min	15	30
Diametro cappa di aspirazione Diametre of exhaust hood Durchmesser der Absaughauben Diamètre buse d'aspiration Diámetro capa de aspiración	mm	∅ 150	∅ 150 x 2
Capacità impianto di aspirazione Exhaust installation capacity Leistung des Absauganlage Capacité installation d'aspiration Capacidad instalación de aspiración	mc/h	1780	3560

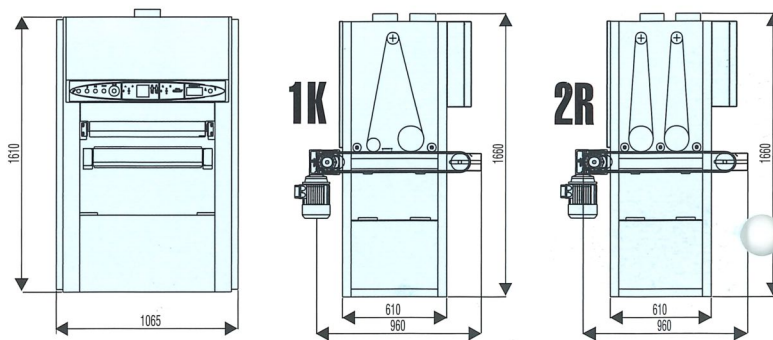

Dimensioni d'imballo  
Packing dimensions  
Abmessungen der Verpackung  
Dimensions d'emballage  
Dimensiones de enclaje

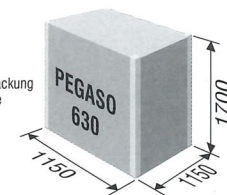

## SICAR spa

via Lama, 30 - 41012 Carpi (Modena) - Italy  
Centralino Tel. 059/633111  
Vendite Italia Fax 059/642639  
Vendite Estero Fax 059/690520  
www.sicar.it E-mail: sicarspa@tin.it

Stabilimenti: Carpi  
Limidi di Soliera  
Villa Bartolomea



La Ditta SICAR S.p.A. si riserva il diritto di modificare qualsiasi specifica senza preavviso.

The company SICAR S.p.A. reserves the right to make any modification retained opportune without any prior notice.

Die Firma SICAR S.p.A. behält sich das Recht vor, Änderungen und Verbesserungen auf den Maschinen ohne Vorankündigung vorzunehmen.

La Maison SICAR S.p.A. se réserve le droit de procéder sans aucun préavis à toute modification retenue opportune.

La firma SICAR S.p.A. se reserva el derecho de modificar cualquier especificación sin previo aviso.

## SICAR SERVICE

☎ 39/059/633131

Fax 39/059/643318