

ONE TOUCH

THE NEW DIMENSION IN EDGE PROCESSING

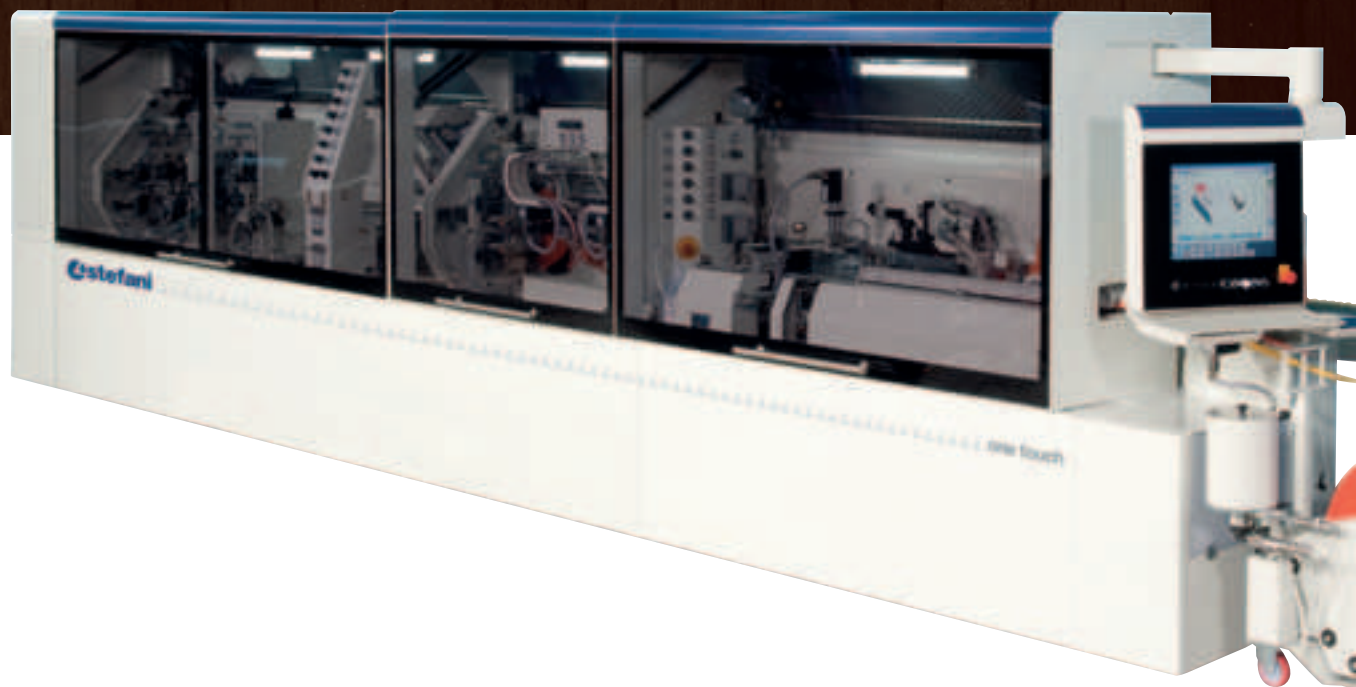

UNMISTAKABLY EFFICIENT

With the exclusive “One Touch” concept for automation and for flexible, varied production.

With the EPP package which allows competitive energy policies and reduced raw material consumption.

UNMISTAKABLY LEADER

For build quality, sturdiness and attention to detail.

UNMISTAKABLY TECHNOLOGICAL

With more than 10 innovations for increased, improved production.



Only a finger for a fully automatic edg banding process



Compact edgebander for industrial production



Interactive and virtual programming sceneries

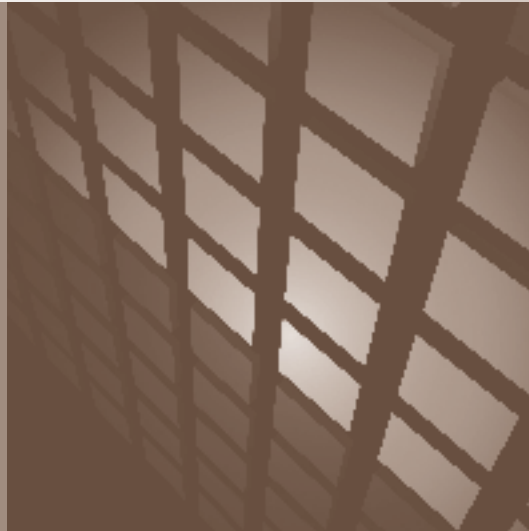

UNIVERSAL EDGE BANDING

ONE TOUCH makes it possible to apply thin and melamine edging, plastic edging made of PVC, ABS, PP, HIGH GLOSS, PMMA, 3D, ready-cut veneer strips and solid wood strips with top quality and without splinters.

ONE TOUCH



EASY GLUE INDUSTRY

It 'a new concept of glue distribution system. It allows to change in a few minutes up to 5 types of glue, different for color or typology (hot melt or polyurethane glue).

The glue change is always realized with the closed cabins, with only a touch of the screen.

MULTIEDGE:
DYNAMIC WORKING
PROCESS CHANGE



KIT MULTIEDGE

To automatically change between 2 radiuses and infinite thin edges, without tool change. Available on fine trimming, corner rounding and edgescraping units.

Patent pending.



Compact edgebander for industrial production



VERY HIGH AND QUALITATIVE PRODUCTION

ONE PANEL BATCH FLEXIBLE PRODUCTION

The ONE TOUCH software allows the dynamic program change and the independent management of each working unit to avoid the machine emptying in process change.

Thus there is no downtime and high productivity is guaranteed.

Belt-style upper presser with NC positioning

The belt presser is made of steel and allows operating speeds of up to 30 m/min. with absolutely no vibrations.



PRODUCTION MANAGEMENT WITH BAR CODE READER

It's possible to manage the production flow through bar codes that identify the type of production and the material to be processed.



OUTFEED TRANSFER.

Maximum comfort.

Device available as standard for the integration of ONE TOUCH with the most modern handling systems.



PANEL SPACING DEVICE INCLUDED

WORKING UNITS WITH BRUSHLESS MOTORS AND MOVEMENTS ON CAGED BALL DEVICES.

For higher performance of movement speed, extreme positioning accuracy and repeatability of movements.

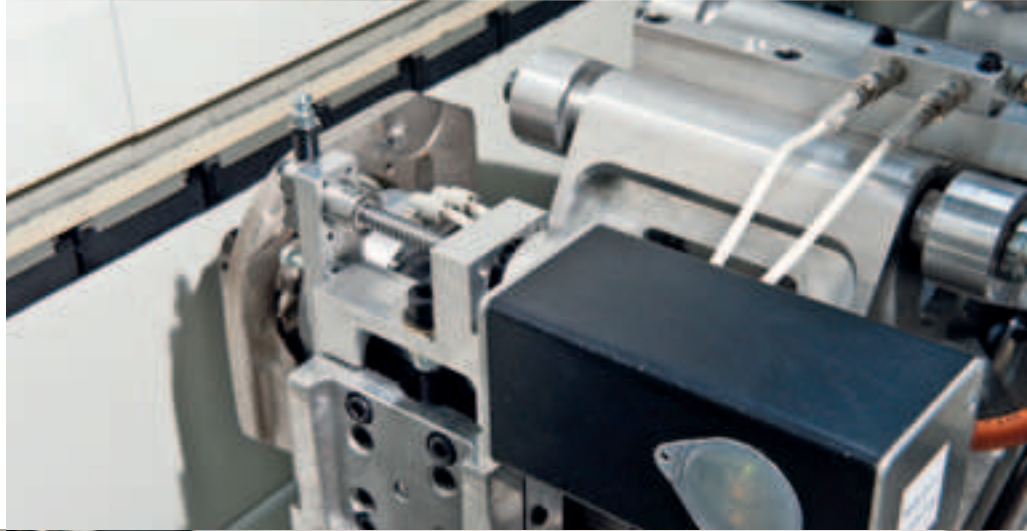

GROOVE PROCESSING

Possibility to process all types of grooves (through or timed grooves on the top, bottom and sides of the panel) to make any production request.

Possibility in some specific machining operations, to work against the direction of feed for perfect cleaning.





Compact edgebander for industrial production



X-GRINDER PERFECT QUALITY IN BAR MACHINING

Waste grinding system built into the extractor hoods of the edge scraper unit helps to reduce the size of the waste when machining medium - long panels or bars (optional device, STEFANI patent pending)

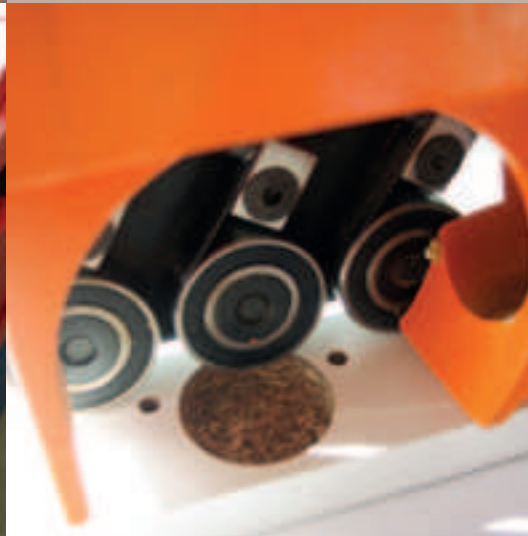

Special feeler kits available in the trimming, fine trimming and edge scraping units for edge banding panels previously machined with the nesting process. The kit has quick releases for rapid interchangeability with standard feelers. An exclusive STEFANI solution allows nesting machining even with the use of the corner rounding unit.

ED SYSTEM EFFICIENT SHAVINGS CUTTING AND EXTRACTION

The ED-SYSTEM optimised extractor system improves extraction quality and performance using extraction tools and hoods specially designed for this purpose. With this technology, the shavings produced are very small and are always removed from the workpiece in a controlled way. ED-SYSTEM is available on panel pre-milling, trimming, fine trimming and corner rounding units.



Standard shavings

ED-SYSTEM shavings

Specific channels and trajectories for shavings extraction

STEFANI SOLUTIONS WHICH IMPROVE WORK ERGONOMICS

TOURER. PANEL RETURN DEVICE

ONE TOUCH can be set up with the TOURER panel return device. A single operator can perform complete machining of the panel directly from the edge banding machine loading zone



INFEEED SYSTEMS SIMPLY EXTEND POTENTIAL



Infeed system derter for narrow workpieces

This device can be set up, facilitating the insertion of smaller panels

Infeed system for large workpieces

Optional device which facilitates transversal insertion of medium/large panels. The reference guide can be tilted to allow the insertion of panels with angled sides.



Interactive and virtual programming sceneries



Working with ONE TOUCH is fast and easy thanks to a nice **PC touch screen** interface that guides the operator in the **self-programming**, according to the logic of “what” to do and not “how” to do. Convenient 17” display for a quick and precise choice of the functions.

PERFECTION AS TARGET ALREADY FROM CONTROL

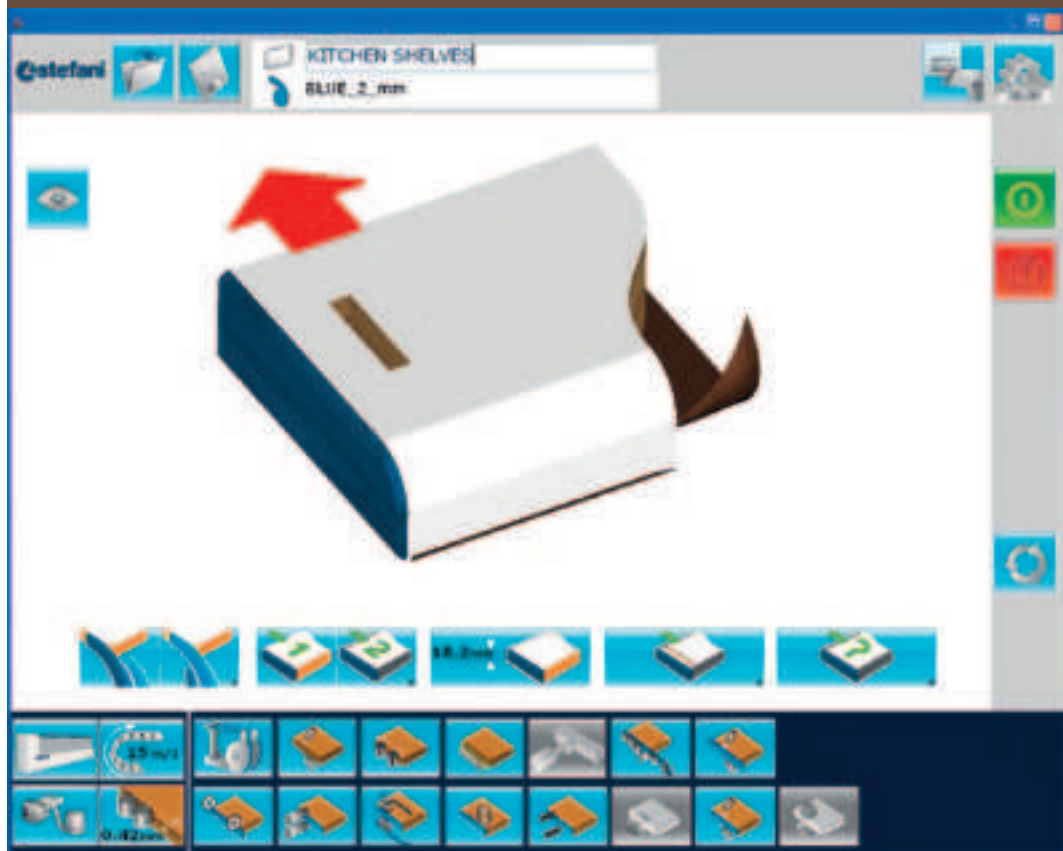

- ▶ Separated management of working units for one panel batch production.
- ▶ Independent management between top and bottom or front and rear process for the different working units.
- ▶ The edge perfectly “marries” the program with the tolerance correction of edge thickness.
- ▶ Production reports.



ONE TOUCH

ADVANCE DIAGNOSTICS

For each working unit it's possible to know in real-time if it is in set-up status, in working or in alarm condition. Different colors indicate the status of the working unit.

SAFETY IN THE TIME

Possibility of continuous self-backup of the PC with additional hard disk.



WEB-BASED TELEDIAGNOSIS

The special hardware structure of ONE TOUCH allows teleservice through internet connection. This allows our trained technicians to access all machine levels from STEFANI resulting in the diagnosis and resolution of most problems or to update the programs according to customer requests in real time.



Compact edgebander
for industrial production

REAL INNOVATION IN EDGE GLUING

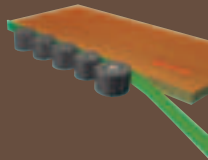

Gluing unit



Allows high quality application of the edging in a 0.4 - 3 mm roll, applied with hot-melt glue. Feeler device for optimising glue dosing comes as standard. Pressure zone consists of a large, motor-driven, clutch-controlled first roller and of three subsequent straight rollers and two tapered ones for optimum pressure on the panel edging. Standard NC management of the pressure

of the pressure roller for hot-melt glue pellets. Possibility of working with ready-cut/ solid wood strips 0.4 - 20 mm thick, with optional WOOD PACK and STRIPES PACK packages. Self-clean function for continuously cleaning the glue roller during production.

Smart edge device for substituting the edging strip with cabins closed. 2 rolls always automatically interchangeable (at the end of a roll and program change) with the possibility of a further 4 locations for storing rolls on the machine. Horizontal magazine. Possibility of a single roll.

ONE TOUCH

Different compositions of the gluing unit allow to satisfy all production needs:

With **EASY GLUE INDUSTRY (patent pending device)** it's possible to change in a few minutes, with only a touch of the screen, between 5 different hot melt glue colors or between hot melt glue, polyurethane glue and cleaner.
The use of different types of glues in closed system is possible with **automatic dosage**.
The glue pot of EASY GLUE is a **patented device**.

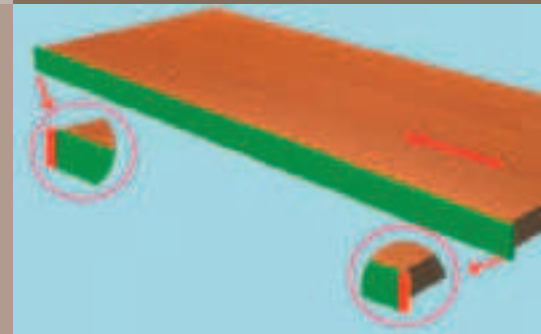

Edging can be fed with a precision of +/- 2 mm on the front and rear parts of the panel. This reduces the production costs for each panel.

Possibility of a PU melt on demand glue pre-melting unit

Optional simultaneous use of pre-melting units for pellets of hot-melt glue and blocks of polyurethane glue.

On the EASY GLUE INDUSTRY version there's the possibility of NC "MICRO DOSING" adjustment of glue dosing. Built in MELT ON DEMAND pre-melting unit for PU block glue capacities of from 2 kg to 8.5 kg/h.

◀ QMS pre-melting unit for hot-melt glue capacities of up to 8.5 kg/h. Automatic drawing and 4 kg hopper of pellets easily filled in an ergonomic way.



Compact edgebander
for industrial production

HEAVY DUTY WORKING UNITS SUPERIOR TECHNOLOGY

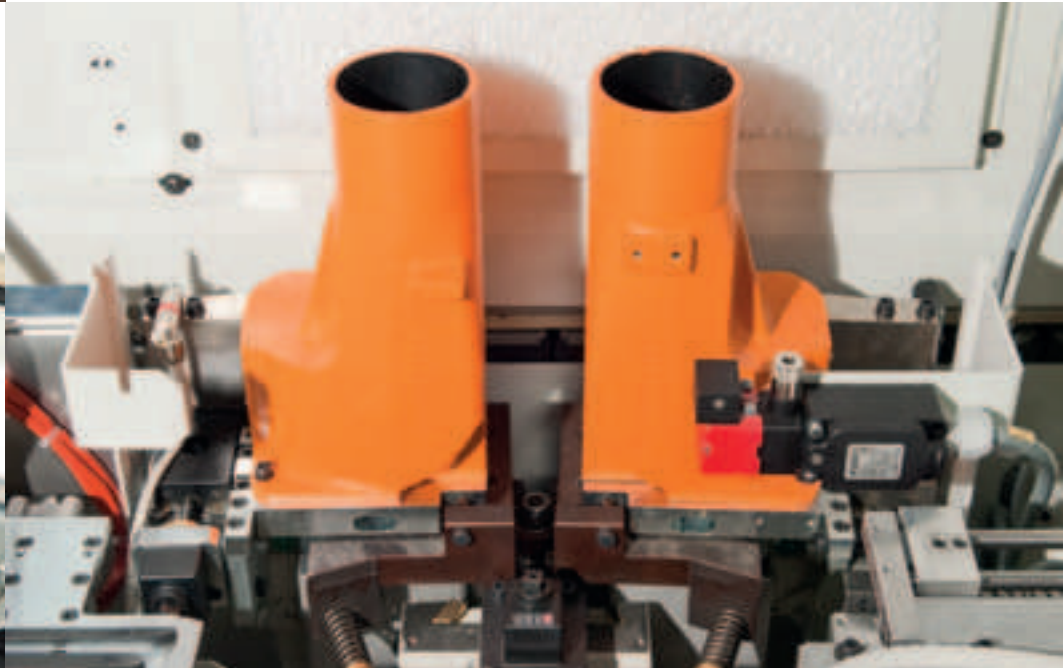

Anti-adhesive
unit

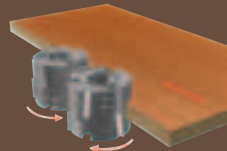
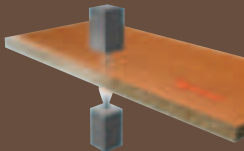

Pre-milling
unit



To avoid glue deposits on the top and bottom surfaces of the panel.



- It mills the panel side to be edged to assures an excellent gluing surface.
- Possibility of NC managed positioning of the first feeler
- Possibility to equip the tools with **HYDROLOCK** technology to reduce coupling plays and vibrations
- Optimized chip suction flow with **ED-SYSTEM** and diamond tools.
- Possibility to equip the EASY SIZE device, to manage. from NC material removing depending on the applying edge.



To pre-heat the panel side to be edged for a better glue adhesion.



Heating panel
lamp unit

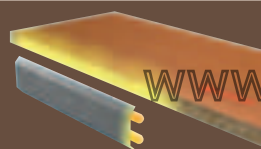

ONE TOUCH

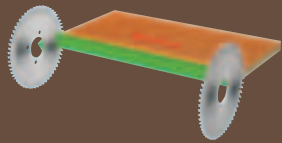
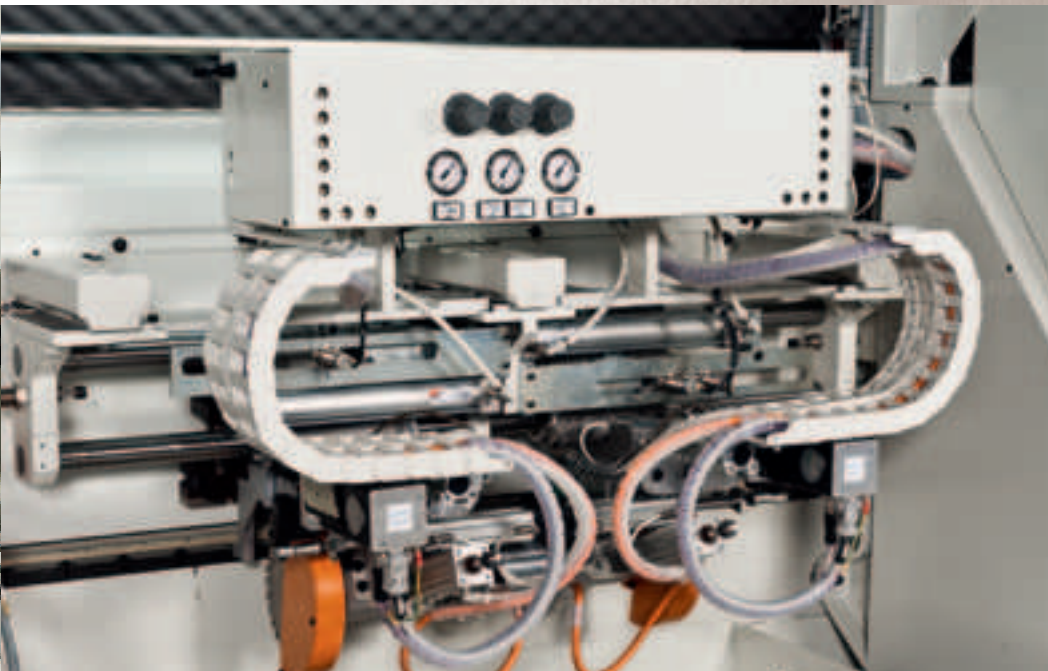

Horizontal end-trimming unit

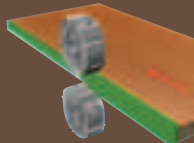

Trimming unit

- ▼
- For the removal of the exceeding edge from the front and rear sides of the panels with minimum 120 mm length
- Possibility of NC management of edge thickness.
- Possibility of separated tilt of the blades to independently process the front and rear sides of the panel
- Saw blade motor on prismatic guides.

- ▼
- For the top and bottom trimming of the edge excess
- Possibility of NC double automatic positioning
- Possibility to work separately top or bottom motors
- Optimized chip suction flow with **ED-SYSTEM**.
- Availability of special feelers for the edgebanding of nested panels.



Compact edgebander
for industrial production

HEAVY DUTY WORKING UNITS PERFECT EDGE FINISHING



- 2-motor version for finishing with corner rounding and edge sanding of the panel edged with melamine, PVC, ABS, PP, PMMA edging.
- Quick release device for tool taper block and tool, for setting up more machining.
- Possibility of a NC lateral tracer for working different thicknesses or compensating for tolerances.
- Optimised extractor flow with the ED-SYSTEM.
- Possibility of setting up the 2P kit for automatically working a thin edging and a radiused edging using NC.
- Possibility of setting up the Multiedge kit for automatically working a thin melamine edging and two radiused edging strips with perfect quality (**PATENTED BY STEFANI**).

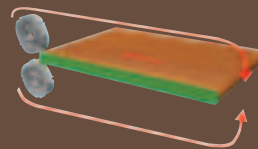

Corner rounding –
fine trimming unit

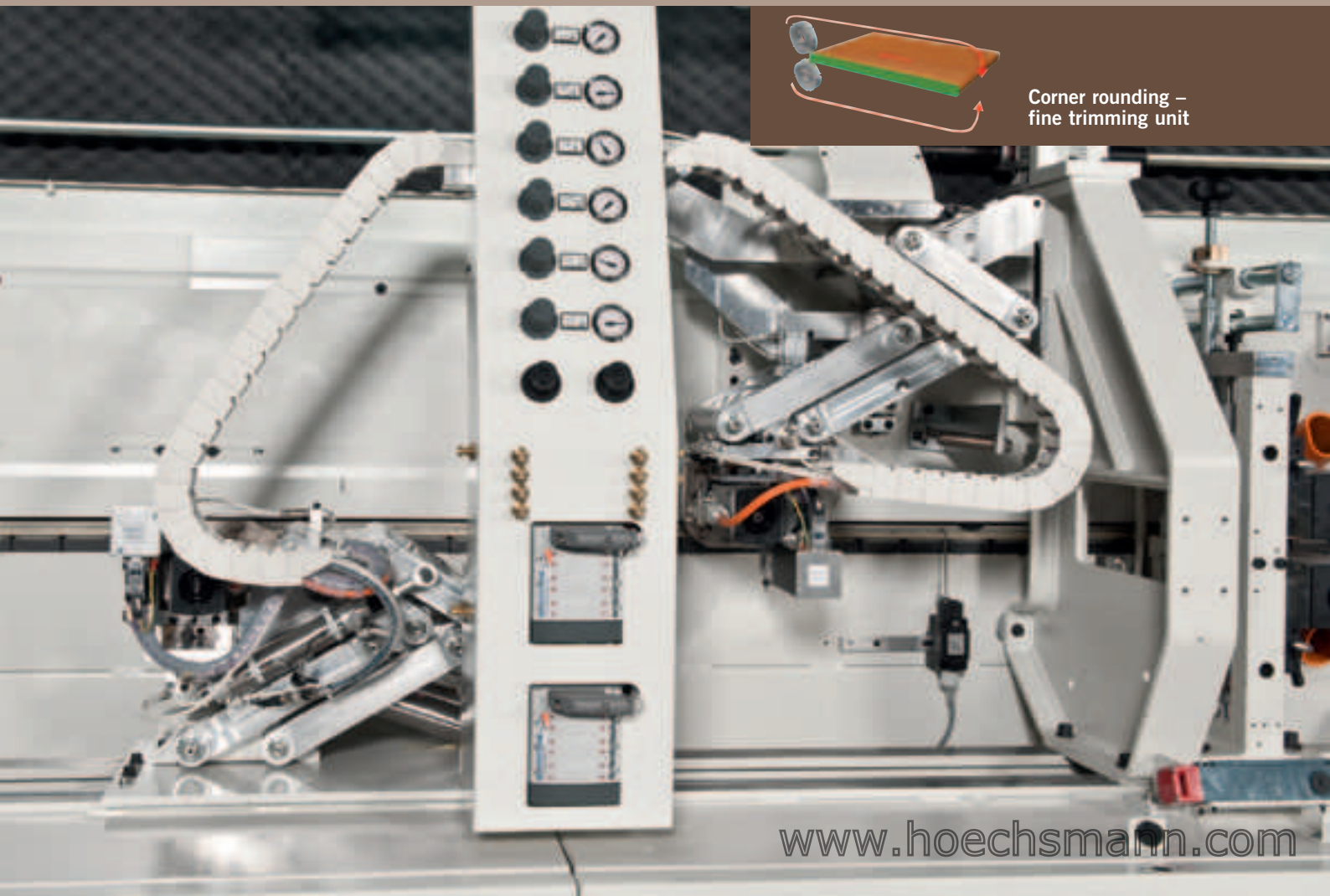

ONE TOUCH

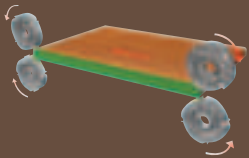
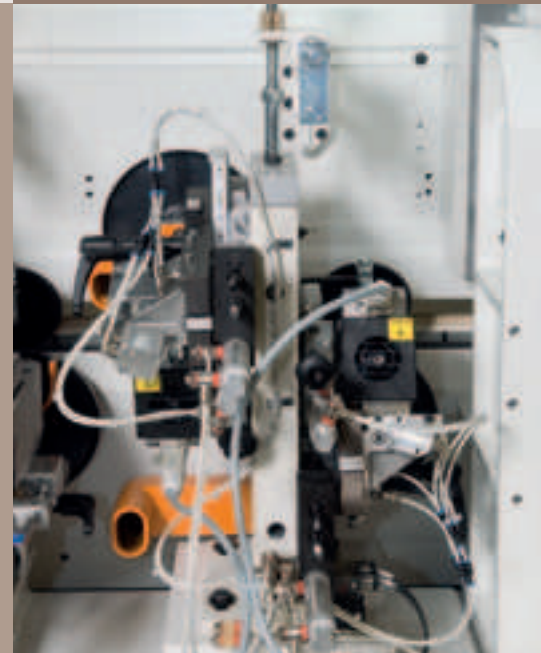
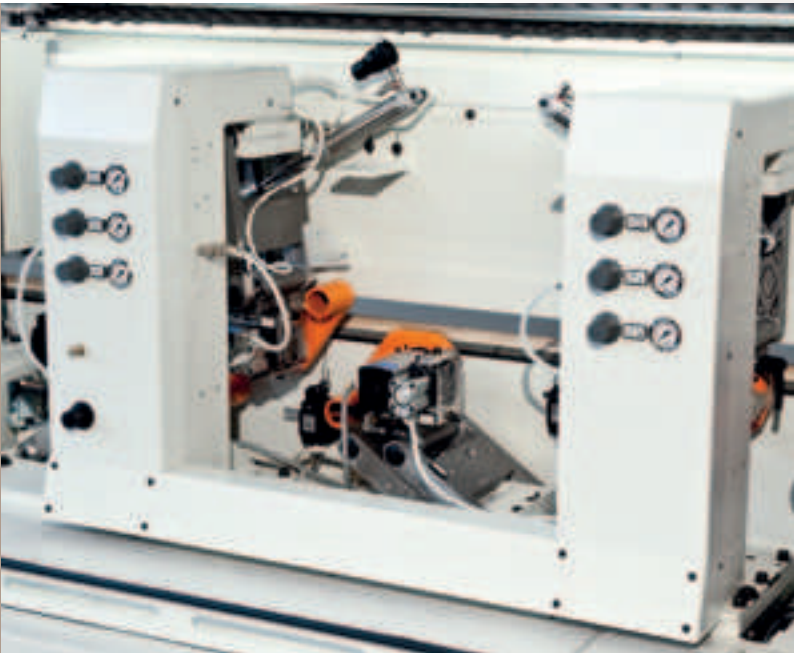

Corner rounding unit

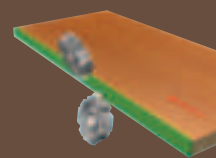

Fine trimming unit



• 4-motor version for finishing with corner rounding and fine trimming of the panel edged with melamine, PVC, ABS and solid wood. • Quick release device for tool taper block and tool, for setting up more machining. • Possibility of a NC lateral feeler for working different thicknesses or compensating for tolerances. • Possibility of setting up the 2P kit for automatically working a thin edging and a radiused edging using NC. • Possibility of setting up the Multiedge kit for automatically working a thin melamine edging and two radiused edging strips with perfect quality. • Optimised extractor flow with the **ED-SYSTEM**.



• For upper and lower finishing of the excess thin edging and for fine trimming of PVC/ABS edging • Quick release device for tool taper block and tool • Possibility of a NC lateral feeler for working different thicknesses or compensating for tolerances • Availability of special feelers for edge banding panels previously machined with the nesting process • Also available in the version with **MULTIEDGE KIT**, for automatically swapping between two radiuses and infinite thin edging strips, or in the **MULTIPLA** version for automatically swapping between three radiuses and infinite thin edging strips.





Compact edgebander for industrial production

HEAVY DUTY WORKING UNITS BEYOND THE QUALITY

- To process through or timed grooves on the top, bottom and sides of the panel
- Quick release device for the suction hoods
- Intervention precision up to ± 2 mm.
- Possibility of working with the rotation against the feed direction.



- For the finishing of PVC/ABS/PP/PMMA rounded edges
- Quick release device of the block composed by tool holder and tool
- Availability of special sensors for the edgebanding of nested panels.
- Possibility of setting up the 2P MULTIEDGE kit for automatically working two radiused edging strips.
- Possibility of setting up the MULTIPLA kit for NC working of a thin melamine edging and three radiused edging strips with perfect quality.
- X-GRINDER waste grinding system built into the extractor hoods to reduce the size of the waste when machining medium - long panels or bars (optional device, **STEFANI patent pending**)



Grooving unit

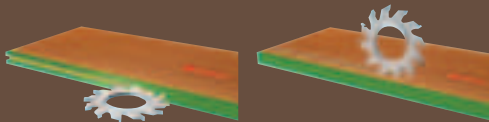

Edgescraping unit

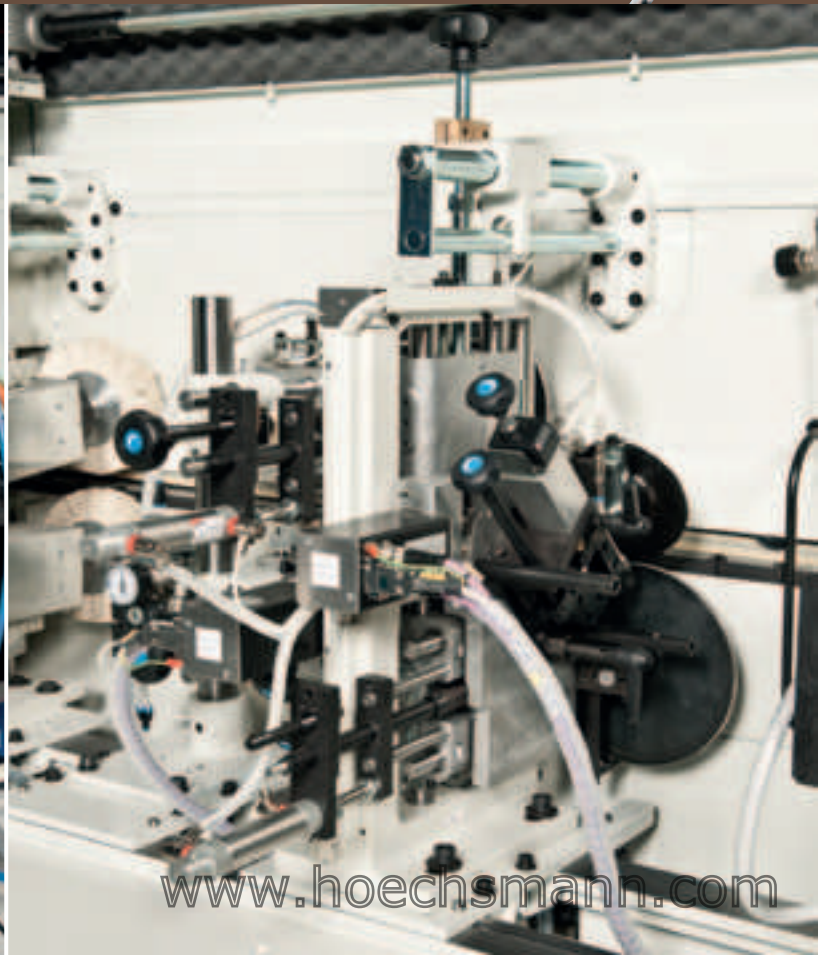
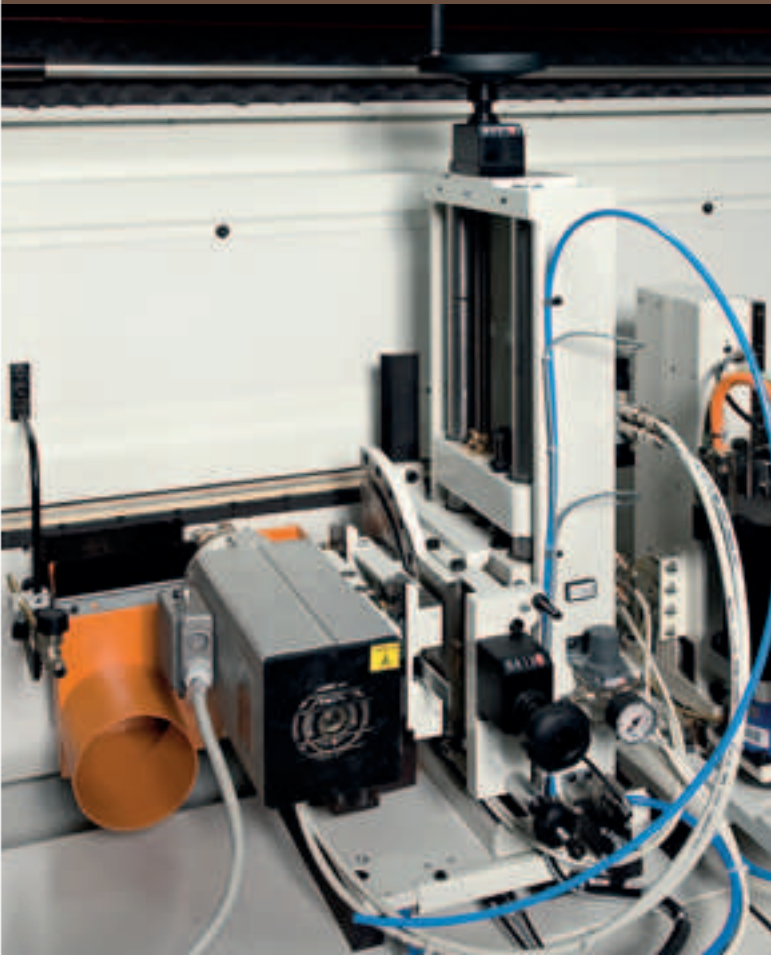
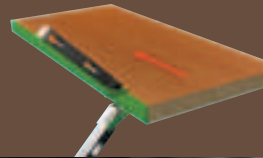

ONE TOUCH

- To eliminate possible residual glue on the top and bottom side of the panel.
- Double bearing feelers for a perfect process precision. Possibility of separated exclusion of the two tools.



For the panel cleaning and the brightening of plastic edges.



Glue
scraping unit

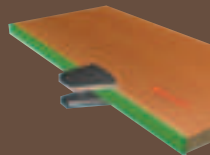

Buffing
unit

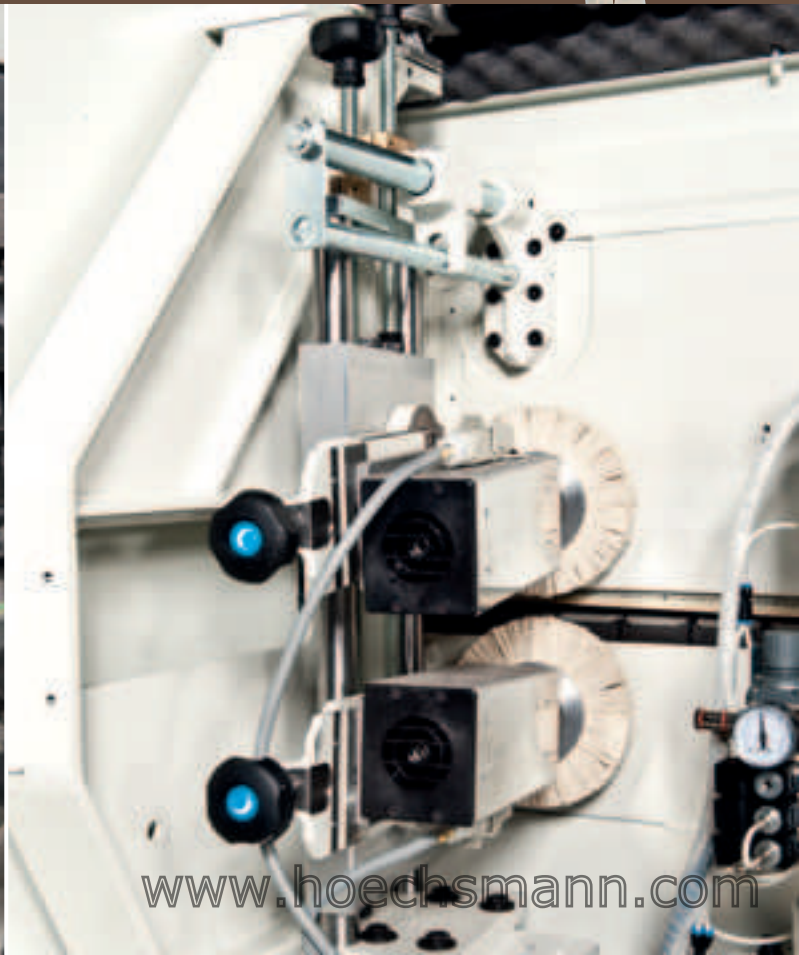
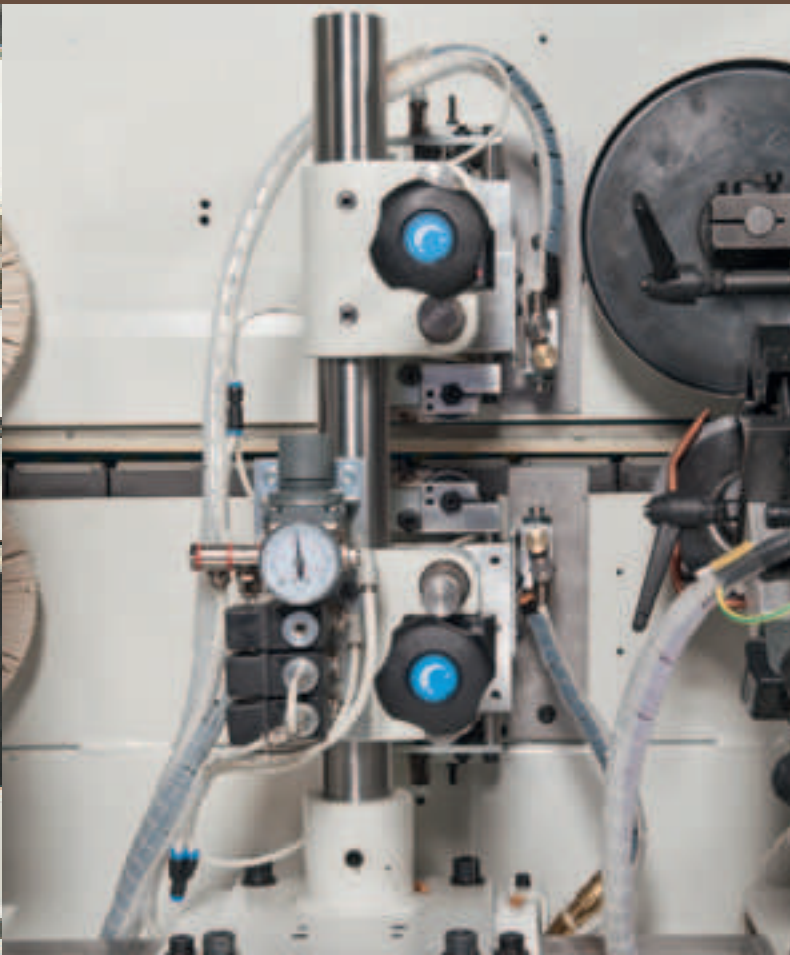
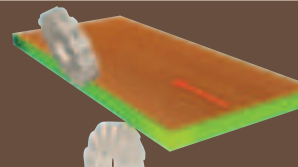

EPP

ECO POWER PACK: A REAL SAVING POTENTIAL

ONE TOUCH is equipped with EPP – ECO POWER PACK, which allows a notable saving of power and material.

▶ **ED-SYSTEM suction:** effective chip and dust evacuation is ensured, with lower power consumption and better cleaning of working units and machine.

▶ **OPTI-CUT** device: precision edge feeding and rear cut to reduce the scrap to a minimum for significant advantages of edge saving.

▶ If the machine is not in use, the track feeding automatically goes on stand-by and the glue pot temperature drops.

▶ Possibility of separated management of suction hoods.



ACR UNIT

Cleaning device for glue scraping and edge brightening units.



ASR UNIT

Placed before the trimming unit, prevents the plastic edge scrap sticking to mechanical machine components. It helps to cool the temperature of the glue previously applied by gluing unit.

In addition to the anti-adhesive unit, ONE TOUCH can be equipped with devices that spray specific liquids to improve the working unit efficiency.

ONE TOUCH



OPTIONAL FIXED PANEL SUPPORT



STANDARD ADDITIONAL EXTERNAL PRESSURE ZONE
Allows high quality finishing even when machining small/narrow workpieces

STANDARD TELESCOPIC PANEL SUPPORT

ONE TOUCH

COMPOSITIONS AND TECHNICAL DRAWINGS

ONE TOUCH A

Suitable composition for edge processing with thin edge in coil 0,4-1 mm without corner rounding. Suitable for not delicate edges in melamine, ABS, PVC, PMMA, PP. Strips max 1 mm (opt) for not delicate edges in melamine, ABS, PVC, PMMA. Strips max 1 mm for plastic material or veneer(opt). Strips max 20 mm (opt) for edges in solid wood. Main optional packages ONE TOUCH A: COMFORT PACK-THIN, COMFORT PACK-2P, COMFORT PACK - THIN+2P, WOODPACK, STRIPES PACK, EPP PACK, PACK 80 mm, NESTING PACK, CLEAN PACK, HYDRO LOCK PACK, BI GLUE PACK, EASY GLUE INDUSTRY PACK, PU PACK

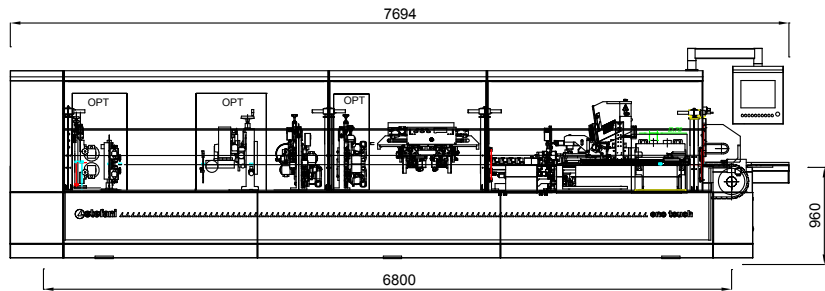

ONE TOUCH B

Suitable composition for edge processing with thin edge in coil 0,4-1mm without corner rounding. Suitable for not delicate edges in melamine, ABS, PVC, PMMA, PP, 3D with edge scraper. Strips max 1 mm (opt) for not delicate edges in melamine, ABS, PVC, PMMA. Strips max 20 mm (opt) for edges in solid wood. Main optional packages ONE TOUCH B: COMFORT PACK-THIN, COMFORT PACK- 2P, COMFORT PACK-THIN+2P, WOODPACK, STRIPES PACK, EPP PACK, PACK 80 mm, NESTING PACK, CLEAN PACK, HYDRO LOCK PACK, BI GLUE PACK, EASY GLUE INDUSTRY PACK, PU PACK

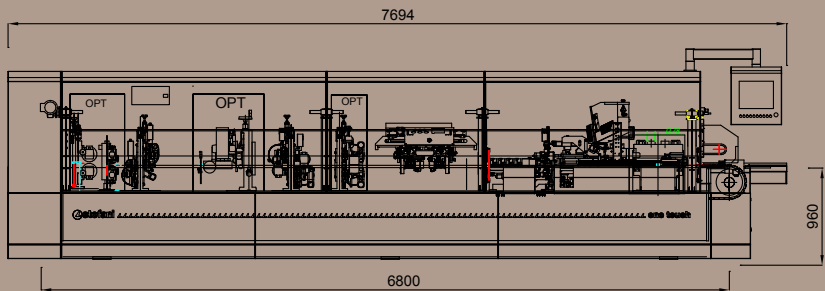

		Free space for grooving unit U
		Free space for TRIMMING UNIT RSP
		SUPER FINISH AREA 2-S Free space for 2 units: Edgescraper RCA and/or brushing unit SP/F

ONE TOUCH C

Suitable composition for edge processing with thin edge in coil 0,4-3 mm with corner rounding. Suitable for not delicate edges in melamine, ABS, PVC, PMMA, PP, 3D. Strips max 1 mm (opt) For not delicate edges in melamine, ABS, PVC, PMMA. Strips max 20 mm (opt) for edges in solid wood of the most types. Main optional packages ONE TOUCH C: COMFORT PACK- 2P, COMFORT PACK-VALUE 3P, COMFORT PACK- THIN+2P, COMFORT PACK- THIN+VALUE 3P, WOODPACK, STRIPES PACK, EPP PACK, PACK 80 mm, NESTING PACK, CLEAN PACK, HYDRO LOCK PACK, BI GLUE PACK, EASY GLUE INDUSTRY PACK, PU PACK

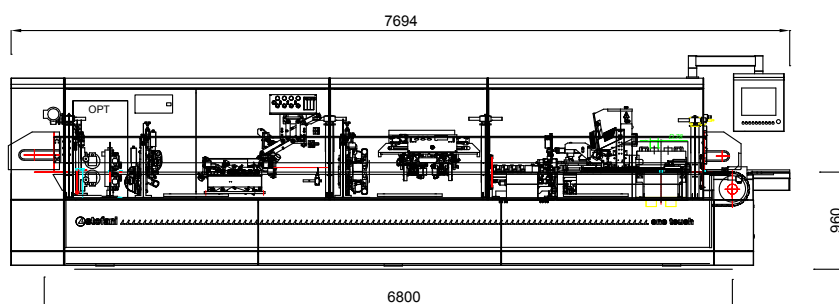
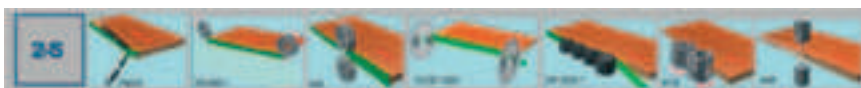

ONE TOUCH

COMPOSITIONS AND TECHNICAL DRAWINGS

ONE TOUCH D

Suitable composition for edge processing with thin edge in coil 0,4-3 mm with corner rounding and the possibility of grooves. Suitable for not delicate edges in melamine, ABS, PVC, PMMA, 3D. Strips max 1 mm (opt) for not delicate edges in melamine, ABS, PVC, PMMA. Strips max 20 mm (opt) for edges in solid wood of the most types. Main optional packages ONE TOUCH D: COMFORT PACK- 2P, COMFORT PACK-VALUE 3P, COMFORT PACK- THIN+2P, COMFORT PACK- THIN+VALUE 3P, WOODPACK, STRIPES PACK, EPP PACK, PACK 80 mm, NESTING PACK, CLEAN PACK, HYDRO LOCK PACK, BI GLUE PACK, EASY GLUE INDUSTRY PACK, PU

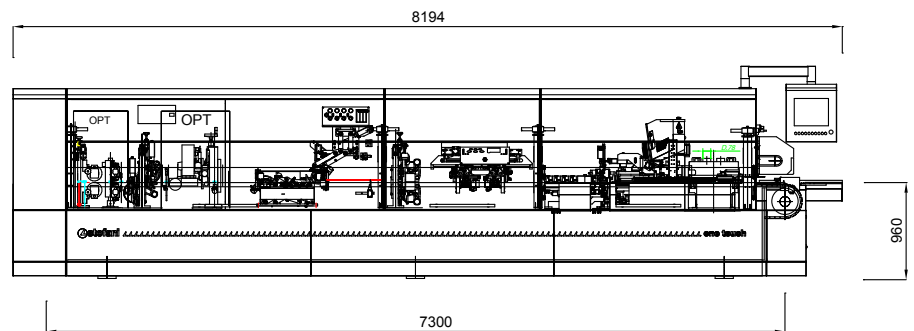

ONE TOUCH E

Suitable composition for edge processing with thin edge in coil 0,4-3 mm with corner rounding. Suitable for delicate edges in melamine, ABS, PVC, PMMA, PP, 3D, High Gloss. Strips max 1 mm (opt) for delicate edges in melamine, ABS, PVC, PMMA. Strips max 20 mm (opt) for edges in solid wood of all types Main optional packages ONE TOUCH E: COMFORT PACK- 2P, COMFORT PACK-VALUE 3P, COMFORT PACK- THIN+2P, COMFORT PACK- THIN+VALUE 3P, WOODPACK, STRIPES PACK, EPP PACK, PACK 80 mm, NESTING PACK, CLEAN PACK, HYDRO LOCK PACK, BI GLUE PACK, EASY GLUE INDUSTRY PACK, PU PACK

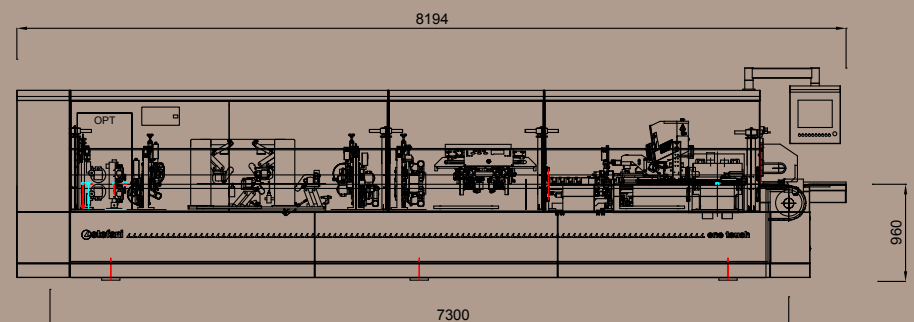

ONE TOUCH F

Suitable composition for edge processing with thin edge in coil 0,4-3 mm with corner rounding and possibility of grooves. Suitable for not delicate edges in melamine, ABS, PVC, PMMA, PP, 3D. Strips max 1 mm (opt) for not delicate edges in melamine, ABS, PVC, PMMA. Strips max 20 mm (opt) for edges in solid wood of all types. Main optional packages ONE TOUCH F: COMFORT PACK-THIN, COMFORT PACK- 2P, COMFORT PACK-VALUE 3P, WOODPACK, STRIPES PACK, EPP PACK, PACK 80 mm, NESTING PACK, CLEAN PACK, HYDRO LOCK PACK, BI GLUE PACK, EASY GLUE INDUSTRY PACK, PU PACK

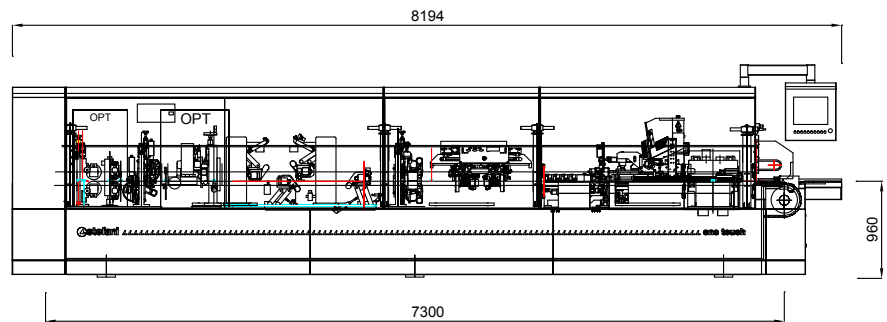

ONE TOUCH

COMFORT PACK – OVER ERGONOMY

CONFORT PACK-THIN

Processing of endless thin edges

	Gluing unit	Trimming unit	Fine trimming unit	2m Corner rounding unit	4m Corner rounding unit	Edgescraping unit
A		NC lateral feelers	NC lateral feelers			
B		NC lateral feelers	NC lateral feelers			
C-D		NC lateral feelers		NC lateral feelers		
E		NC lateral feelers	NC lateral feelers		NC lateral feelers	
F		NC lateral feelers			NC lateral feelers	

CONFORT PACK-2P

Automatic processing of 1 thin edge + 1 radiated edge

	Gluing unit	Trimming unit	Fine trimming unit	2m Corner rounding unit	4m Corner rounding unit	Edgescraping unit
A		NC lateral feelers	2 automatic positions straight/rad.			
B		NC lateral feelers	2 automatic positions straight/rad.			
C-D	2 Pneumatic Positions			2 automatic positions straight/rad.		
E	2 Pneumatic Positions		2 automatic positions straight/rad.		2 automatic positions straight/rad.	
F	2 Pneumatic Positions				2 automatic positions straight/rad.	

CONFORT PACK-VALUE 3P

Automatic processing of 1 thin edge + 2 radiated edges

	Gluing unit	Trimming unit	Fine trimming unit	2m Corner rounding unit	4m Corner rounding unit	Edgescraping unit
C-D	NC pressure area			MULTIEDGE 3 automatic		2 Positions RADIUS 1/RADIUS 2
E	NC pressure area		MULTIEDGE 3 automatic positions with NC lateral feelers		MULTIEDGE 3 automatic	2 Positions RADIUS 1/RADIUS 2
F	NC pressure area				MULTIEDGE 3 automatic	2 Positions RADIUS 1/RADIUS 2

TECHNICAL SPECIFICATIONS

ONE TOUCH

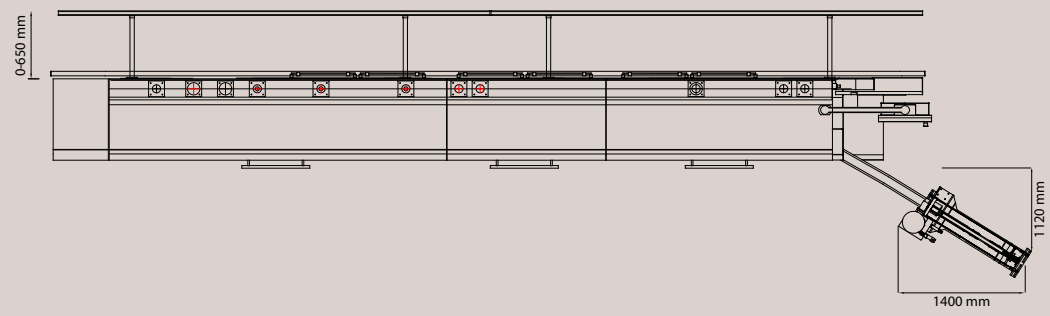
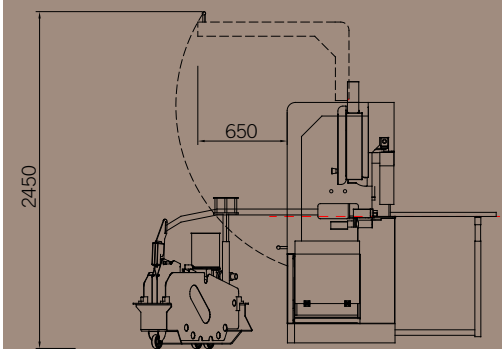
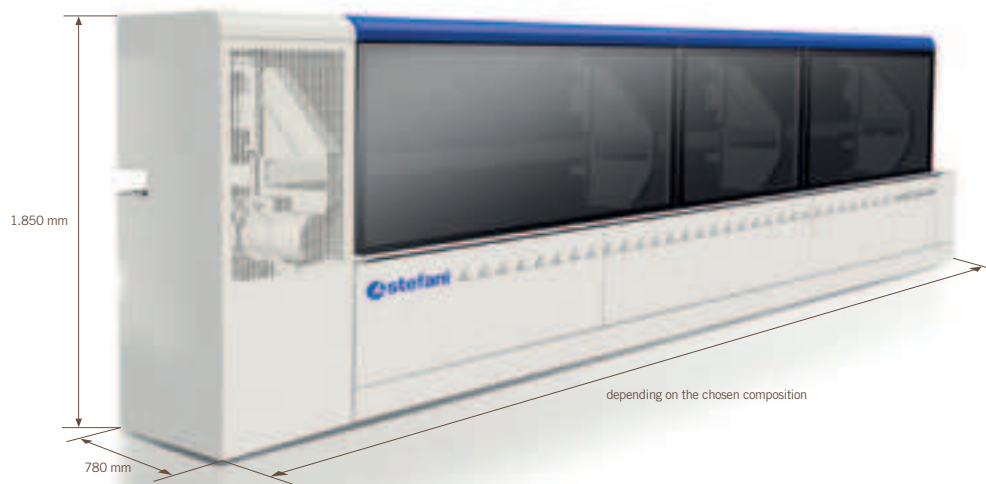

Minimum and maximum coil edge thickness	0,4 - 3 mm
Minimum and maximum strip edge thickness	0.4-20 mm (opt Wood pack, opt Stripes Pack)
Minimum and maximum panel thickness	8-45 mm (opt 8-60 mm, 8-80 mm)
Adjustable feed speed	10-30 m/min
Glue types:	► Hot melt glue ► Polyurethane glue ► Hot melt glue + Polyurethane glue

ONE TOUCH NOISE LEVEL

	Reference standard	VSA	LAV
Sound power level emitted dBw(A) [mW(A)]	EN ISO 3746 : 1995 ISO 7960-95 Annex G	93,5 [2,2]	96,4 [4,3]
Sound pressure level at operator position, infeed	EN ISO 11202 : 1997 ISO 7960-95 Annex G	76,4	80,0
Sound pressure level at operator position, outfeed	EN ISO 11202 : 1997 ISO 7960-95 Annex G	74,2	76,1

NLWE: no load values without extraction OV: operating values

The tests were carried out with air extraction speed equal to 20 m/s.

Uncertainty associated with the measurement of the sound power ≤ 4.0 [dB(A)]
 Uncertainty associated with the measurement of the sound pressure at the operator position ≤ 4.0 [dB(A)]
 The maximum C-weighted instantaneous sound pressure values are less than 130 dB(C).