

# Wadkin

## Cross Cutting and Trenching Machines: C.C. C.D.

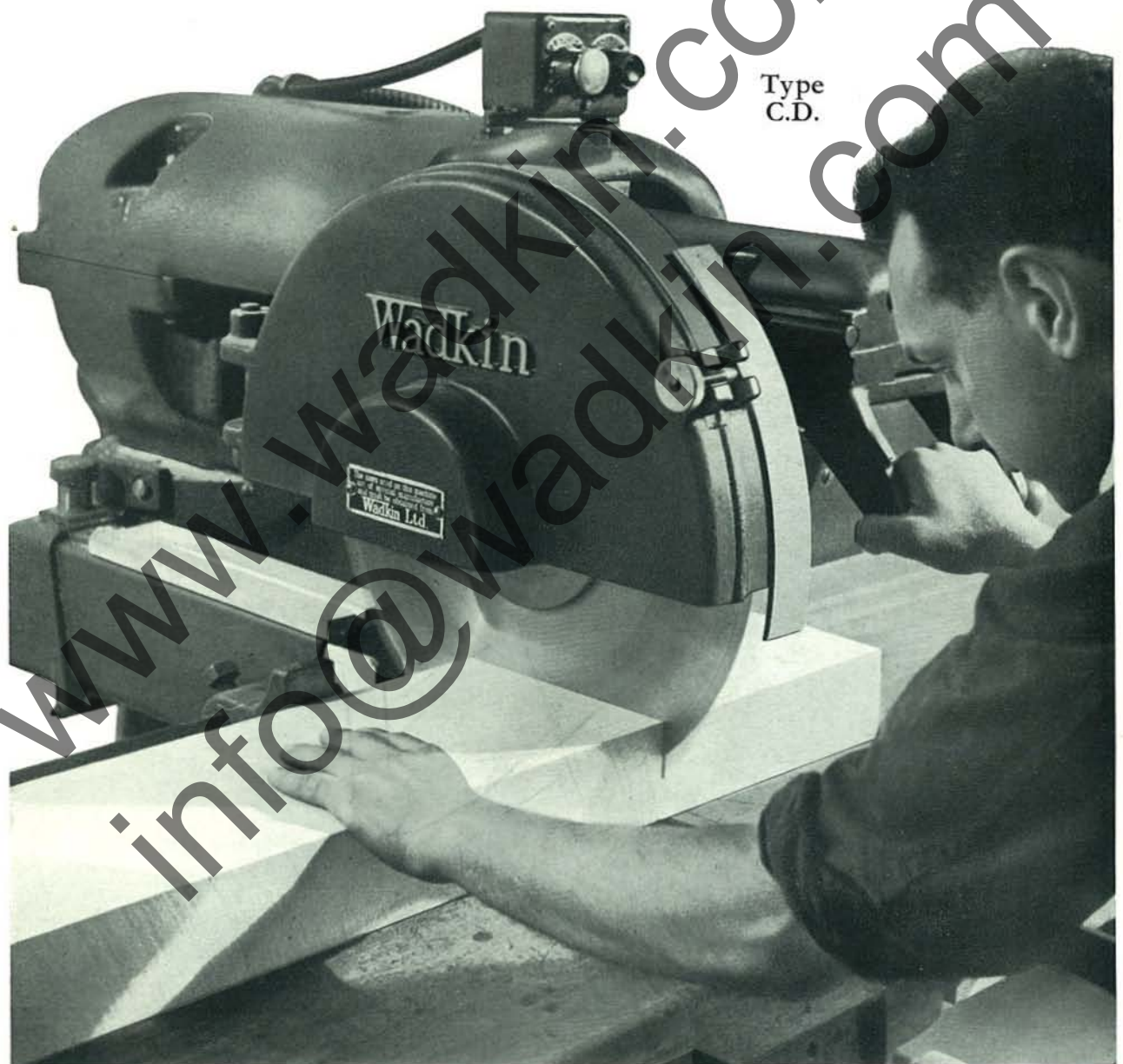

Type  
C.D.

# Wadkin

## Cross Cutting and Trenching Machines

The Wadkin range of Cross Cutting and Trenching machines have become recognised as the leading machines of their type, and the standard of comparison for all other similar machines.

This reputation is the result of a combination of features and advantages which are to be found only in the patented Wadkin design. Chief among these is the patented method of obtaining the straight line cutting action, in such a way that the initial accuracy of the movement can be maintained indefinitely and fast, easy operation ensured.

The Saw Carriage is carried by four ball bearing rollers running on circular steel tracks. This arrangement is ideal because of the smoothness of

the movement—its rigidity, and the fact that it is impossible for the forward movement of the carriage to deviate from a dead straight line in relation to the fence, thus guaranteeing accuracy of cutting throughout the entire life of the machine.

A further big advantage of the design is, that no overhead fixing of any kind is required. All models are self-contained, simple, convenient and inexpensive to install. These characteristics allied with the adaptability of the various machines to many different jobs, make them invaluable production tools in the shop, out in the timber yard, on a building site, or wherever cross cutting and trenching operations are required on a speedy, low cost basis.

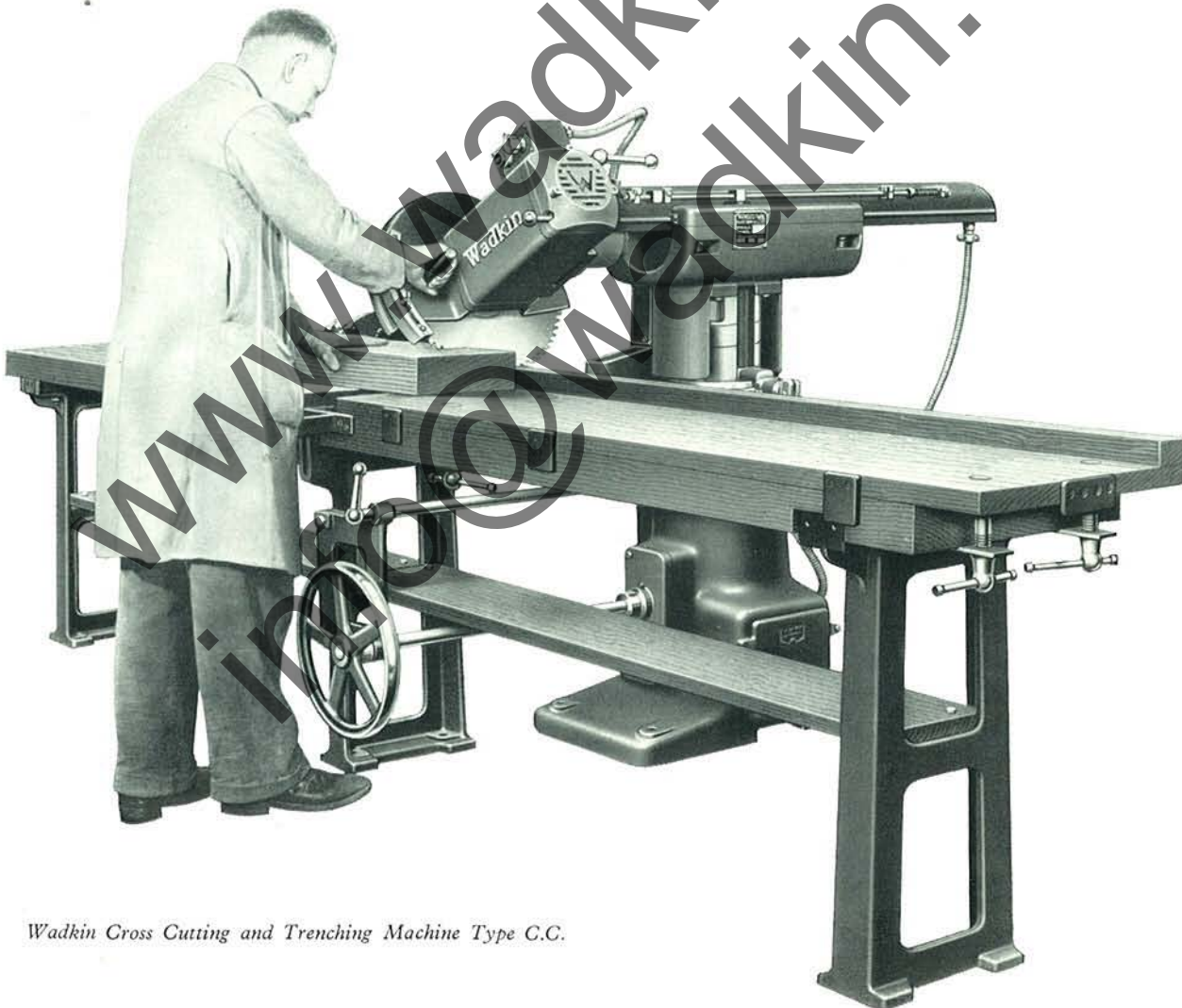

*Wadkin Cross Cutting and Trenching Machine Type C.C.*



## Specification

### The Main Frame

The main frame is machined to receive the circular slide carrying the horizontal saw frame.

### The Sliding Saw Frame

The sliding saw frame is raised and lowered by large handwheel placed at the front of the machine. This motion is operated by machine-cut steel gears and screw, which are enclosed inside the column. The weight is taken by a ball thrust washer.

The slide can be locked where desired. The sliding saw frame may be swivelled for angular cutting, which, together with the canting motion to the saw spindle, enables compound cutting to be done. A plunger pin registers the more important angles, and a degrees scale is provided.

### The Saw Carriage

The saw carriage moves on four ball bearing rollers on circular steel tracks. Not only does this give a smooth easy movement, but the Wadkin method of mounting the rollers prevents side play in the movement and guarantees that the saw carriage moves forward in a dead straight line.

The saw carriage is returned after a cutting stroke by a long spiral spring, and is received at the end of the stroke by a pneumatic buffer, which effectively cushions the rebound of the carriage. Adjustable stops on the saw carriage can be quickly set to limit the length of stroke if desired.

### The Motor

The motor is of the totally enclosed fan-cooled type. It can be supplied for practically any alternating or direct current supply.

The motor is mounted on a trunnion so that it can be canted to any angle from the horizontal to the vertical. A plunger pin registers the more important angles, a degrees scale being also provided. A locking handle securely locks it in any intermediate position.

### The Motor Spindle

The motor spindle is mounted in heavy ball bearings and is made extra long for taking grooving heads or cutterblocks.

### The Spindle Brake

An efficient hand-operated brake is fitted to the saw spindle, for quickly bringing the saw or cutterhead to rest after use.

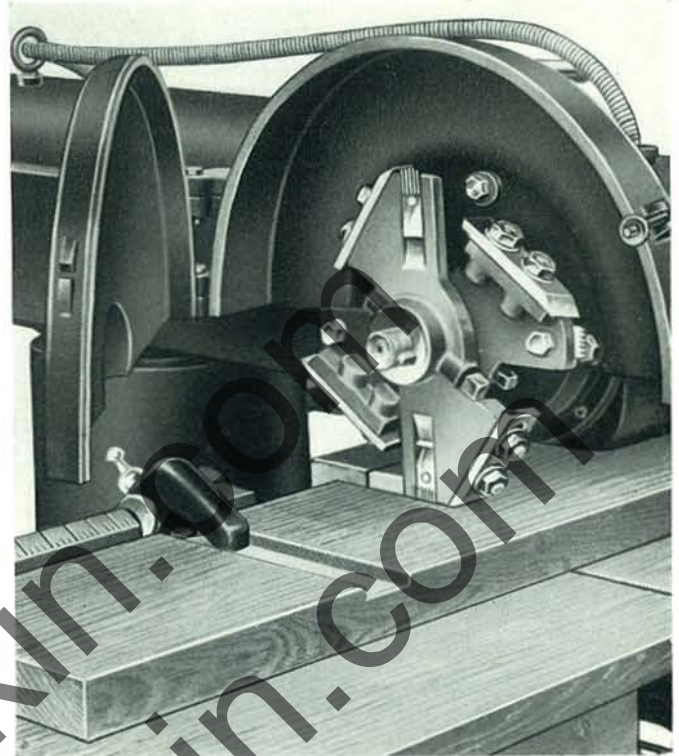

*Saw can be taken off and this expanding grooving head substituted in two or three minutes. Head is quickly set to cut any required width within its capacity.*



*Shows the machine canted for such work as birdsmouthing in roof spars.*



## Specification (Contd.)

### The Control Gear

The control gear is by leading British manufacturers. In the case of alternating current supply, an automatic start and stop push button control is mounted conveniently to the operator's hand, and the contactor gear built into the base of the main column of the machine.

### The Saw Table

The saw table may be of wood and is easily made by the customer in his own shop to suit his particular requirements. In this case a working drawing of the table is supplied by us. We can supply a set of metal legs, as illustrated on page 2. We strongly advise customers to order these with the machine, as they ensure rigidity of the table.

Alternatively, if desired, an all-metal table as shown on page 15 can be supplied.

### An Automatic Stop Bar

An automatic stop bar can be supplied, which dispenses entirely with the necessity of marking out, and for repetition work is a great labour-saver. This stop device is fixed on the back edge of the saw table, as illustrated on page 15. The stop bar is supplied with three stops. Additional stops can be supplied if required.

The stop bar should be mounted on the left of the saw as illustrated on page 15 in order to obtain full advantage of the machine, and to allow the saw to swivel to the right for angular cutting.

### An Adjustable Fence

An adjustable fence as seen in the illustration above may also be supplied for use when several pieces of timber are required to be cut side by side at one operation. This fence is designed to drop on to the stop bar, and it may be attached or detached in a few seconds.

*The Walkin method of mounting the sliding carriage on four ball bearing rollers and circular tracks ensures easy movement and precision accuracy. Two of the four rollers are on eccentric pins quickly adjustable to take up slackness that may develop with wear. NOTE: Cover has been removed to show rollers.*

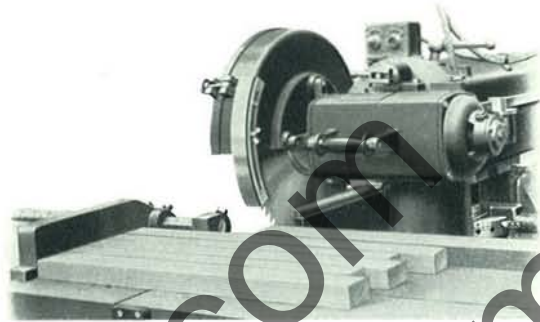

*Showing Adjustable Fence for multiple cutting.*

### The Saw Guard

The saw guard is arranged to give maximum protection to the operator and is hinged for changing and sharpening saws.

### The Saws

The saws used on this machine have special characteristics (as detailed on page 14), and it is therefore advisable to order these from us.

### The Sawdust Hood

The sawdust hood is fitted to the vertical slide frame and is provided with a nozzle for connecting up to a sawdust system.



Dust Proof  
Ball Bearing  
Rollers



### Principal Dimensions and Capacities

	Model C.C.1	Model C.C.2
Standard diameter of saw	18" (457 mm.)	18" (457 mm.)
Will cut off	22" x 5" deep (559 x 127 mm.)	27" x 5" deep (686 x 127 mm.)
Will cut off	23½" x 4" deep (597 x 102 mm.)	28½" x 4" deep (724 x 102 mm.)
Will cut off	25" x 3" deep (635 x 76 mm.)	30" x 3" deep (762 x 76 mm.)
Will cut off	26" x 2" deep (660 x 51 mm.)	31" x 2" deep (787 x 51 mm.)
Will cut off	27" x 1" deep (686 x 25.4 mm.)	32" x 1" deep (813 x 25.4 mm.)
Will straight cut off when saw is canted 45° up to	22" x 1¼" deep (559 x 44.4 mm.)	27" x 1¼" deep (686 x 44.4 mm.)
Will straight cut off when saw is canted 30° up to	22" x 4" deep (559 x 102 mm.)	27" x 4" deep (686 x 102 mm.)
Will cut off when saw is swivelled 45° up to	13¾" x 5" deep (349 x 127 mm.)	18" x 5" deep (457 x 127 mm.)
Will cut off when saw is swivelled 45° up to	15½" x 4" deep (394 x 102 mm.)	19¾" x 4" deep (502 x 102 mm.)
Will cut off when saw is swivelled 45° up to	16½" x 3" deep (419 x 76 mm.)	20¾" x 3" deep (527 x 76 mm.)
Will cut off when saw is swivelled 45° up to	17¼" x 2" deep (438 x 51 mm.)	21½" x 2" deep (546 x 51 mm.)
Will cut off when saw is swivelled 45° up to	17¾" x 1" deep (451 x 25.4 mm.)	22" x 1" deep (559 x 25.4 mm.)
Will straight groove up to 1½" (41.2 mm.) deep	in material 20" (508 mm.) wide	in material 25½" (654 mm.) wide
Will groove when carriage is swivelled to 45° up to 1½" (41.2 mm.) deep	in material 13¼" (337 mm.) wide	in material 17¼" (451 mm.) wide
Maximum rise and fall of saw	9½" (241 mm.)	9½" (241 mm.)
Speed of saw spindle in r.p.m. for 50 cycles electric supply	3000	3000
<i>(Motor can be supplied for practically any Alternating or Direct Current supply.)</i>		
Diameter of saw spindle for saws	1¼" (31.7 mm.)	1¼" (31.7 mm.)
Horse power of motor	5	5
Overall length of each section of all-metal table to cut off up to 8' 0" (2.4 m.) long using stop bar	8' 5" (2.5 m.)	8' 5" (2.5 m.)
<b>Machine only</b>		
Net weight in cwts.	10½ (1150 lbs.) (521 Kilos)	11 (1230 lbs.) (559 Kilos)
Gross weight in cwts.	13 (1450 lbs.) (660 Kilos)	13¾ (1600 lbs.) (699 Kilos)
Shipping dimensions in cubic feet	62½ (1.77 cu.met.)	62½ (1.77 cu.met.)
*Code Word	<b>Croac</b>	<b>Clarc</b>
<b>Machine with Metal Legs for Table</b>		
Net weight in cwts.	12¾ (1430 lbs.) (648 Kilos)	13½ (1510 lbs.) (686 Kilos)
Gross weight in cwts.	15½ (1740 lbs.) (787 Kilos)	16¼ (1820 lbs.) (826 Kilos)
Shipping dimensions in cubic feet	62½ (1.77 cu.met.)	62½ (1.77 cu.met.)
*Code Word	<b>Cleac</b>	<b>Clesc</b>
<b>With Metal Table</b>		
Net weight in cwts.	17¼ (1930 lbs.) (876 Kilos)	19 (2130 lbs.) (965 Kilos)
Gross weight in cwts.	22½ (2520 lbs.) (1143 Kilos)	24½ (2720 lbs.) (1232 Kilos)
Shipping dimensions in cubic feet	87½ (2.47 cu.met.)	94½ (2.68 cu.met.)
*Code Word	<b>Cetac</b>	<b>Cemec</b>
<b>Truck Model</b>		
Net weight in cwts.	15½ (1740 lbs.) (787 Kilos)	(not available)
Gross weight in cwts.	20½ (2300 lbs.) (1041 Kilos)	(not available)
Shipping dimensions in cubic feet	104 (2.94 cu.met.)	(not available)
*Code Word	<b>Cotuc</b>	

\*When using code word, please state particulars of electric supply.

#### Details included with each machine

One 5 h.p. motor, complete with armoured cable to starter.  
 One pair of saw collars, hexagon nut and key.  
 One lubricating pump and sample tin of lubricant for ball bearings.

One starter.  
 Hinged saw guard.  
 Dust-collecting hood.  
 One set of spanners.



## Wadkin Cross Cutting and Trenching Machine, C.D.

This machine is equipped with rising and falling, also swivelling movements to the saw carriage for straight or angular work.

It is an ideal machine for those trades where compound angular cutting is seldom if ever required,

as, with the canting head movement omitted, less operating space is required.

All the examples of cutting shown on pages 4 and 5 can be done on this machine, with the exception of those marked C.C. Model only.

### Features

1. *Saw carriage has raising and lowering motion and can be swung round 45 degrees. Principal angles on swivelling motion are positively located by spring plunger.*
2. *Unique construction of sliding saw carriage and underslung mounting of motor economises valuable floor space.*
3. *Easy operating saw carriage moves on ball bearing rollers on hardened and ground steel tracks. Tracks are easily renewable.*
4. *Rigid powerful straight line action.*
5. *Raising and lowering motion for saw carriage is totally enclosed and the weight taken by a ball thrust washer.*

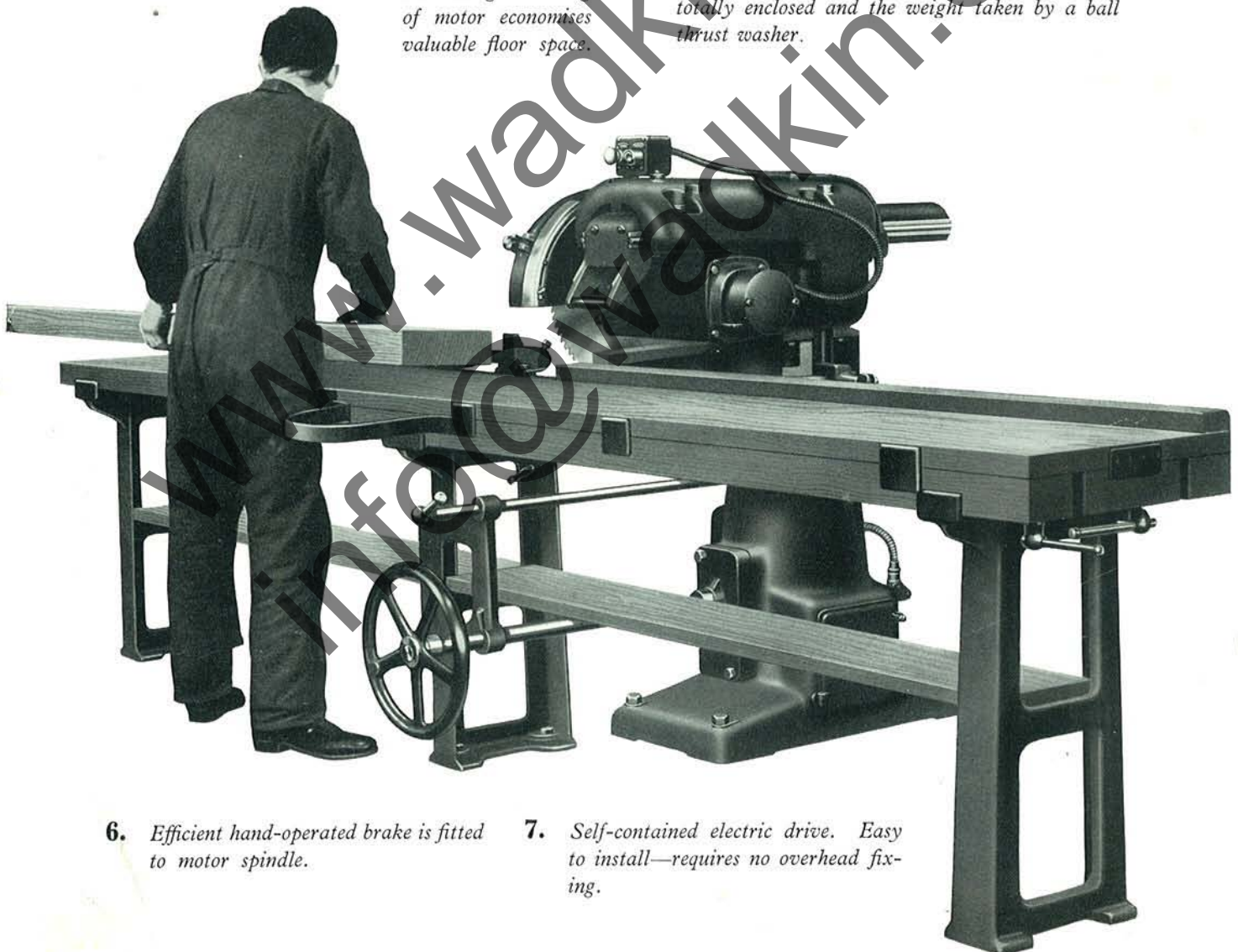

6. *Efficient hand-operated brake is fitted to motor spindle.*
7. *Self-contained electric drive. Easy to install—requires no overhead fixing.*



### Specification

#### The Sliding Saw Frame

The sliding saw frame is raised and lowered by large handwheel placed at the front of the machine. This motion is operated by machine-cut gears and screw, which are enclosed inside the column. The weight is taken by a ball thrust washer. The slide can be locked where desired. The sliding saw frame may be turned round either way for angular cutting. A plunger pin registers the more important angles, and a degrees scale is provided.

#### The Saw Carriage

The saw carriage is a casting of special shape to give lightness, strength and rigidity. It is provided with hardened and ground circular steel runways which slide on ball bearing rollers on the saw carriage frame. Carriage is returned after the cutting stroke by two long spiral springs and received at the end of the stroke by a pneumatic buffer which effectively cushions the rebound of the carriage. Adjustable stops are provided to limit the length of stroke when desired.

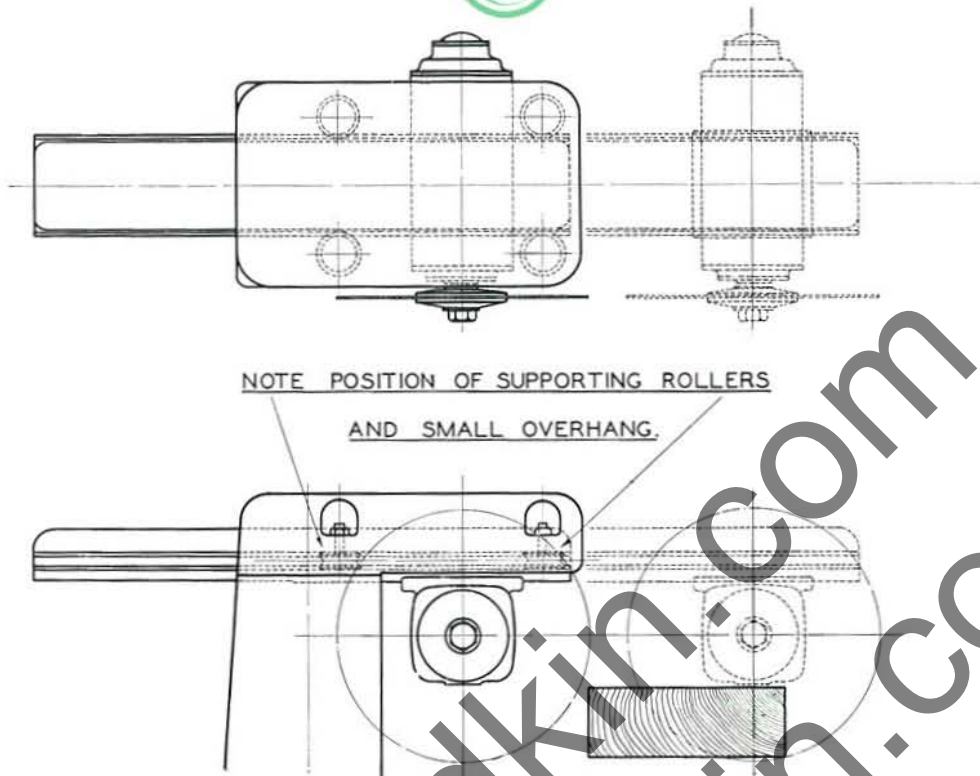

NOTE POSITION OF SUPPORTING ROLLERS  
AND SMALL OVERHANG.

The above outline drawing illustrates the patented design of the Wadkin Saw Carriage on C.D. model.

The motor is underslung, and the saw spindle is well behind the front rollers when the saw is in the back position. This means that the distance between the saw and these front rollers when the saw is cutting, is considerably less than on a machine where the saw spindle is mounted in front of the carriage bearings. The result is that greater rigidity is obtained with a higher degree of accuracy in cutting.

The manner in which the rollers are disposed, also adds to the rigidity and accuracy of the stroke. In the Wadkin design, the bearings are mounted horizontally which gives the most positive control to the straight line action of the machine.

#### The Motor

The motor is of the totally enclosed fan-cooled type. It can be supplied for any alternating or direct current supply. In the case of C.D.3 and C.D.5, the motor is for two- and three-phase alternating current only. The motor spindle revolves in heavy type ball bearings. An efficient hand-operated brake is fitted to the saw spindle.

#### The Control Gear

The control gear is by leading British manufacturers. In the case of alternating current supply, automatic start and stop push button control is self-contained with the machine. For direct current, we supply as standard a dustproof hand-operated starter, but automatic start and

stop push button control can be supplied to special order.

#### The Saw Guard

The saw guard is arranged to give maximum protection to the operator, and is hinged for convenience in changing and sharpening saws. A sawdust hood is securely fixed to the main frame, and is also hinged for convenience in changing saws. It is provided with a nozzle for connecting up to an exhaust system.

#### The Table

If it is desired for customer to make his own table, we can supply a set of metal legs as used in the all-metal table, shown on page 15. We would, however, strongly recommend an all-metal table for use with this machine, because this enables the timber to be more easily and quickly brought into position for cross cutting.

#### An Automatic Stop Bar

An automatic stop bar can be supplied, which dispenses entirely with the necessity of marking out, and for repetition work is a great labour-saver. This stop device is fixed on the back edge of the saw table, as illustrated on page 15. The stop bar is supplied with three stops. Additional stops can be supplied if required.

The stop bar should be mounted on the left of the saw as illustrated on page 15 in order to obtain full advantage of the machine and to allow the saw to swivel to the right for angular cutting. An adjustable fence as illustrated on page 15 can also be supplied.





### Principal Dimensions and Capacities

	Model C.D.1 for material 14" x 5" (356 x 127 mm.)	Model C.D.2 for material 22" x 5" (559 x 127 mm.)	Model C.D.3 for material 16" x 7" (406 x 178 mm.)	Model C.D.4 for material 45" x 5" (1143 x 127 mm.)	Model C.D.5 for material 40" x 7" (1016 x 178 mm.)
Standard diameter of saw ... ..	18" (457 mm.)	18" (457 mm.)	24" (610 mm.)	18" (457 mm.)	24" (610 mm.)
Will cut off ... ..	14" x 5" deep (356 x 127 mm.)	22" x 5" deep (559 x 127 mm.)	16" x 7" deep (406 x 178 mm.)	45" x 5" deep (1143 x 127 mm.)	40" x 7" deep (1016 x 178 mm.)
Will cut off ... ..	15" x 4" deep (381 x 102 mm.)	24 3/4" x 4" deep (629 x 102 mm.)	19" x 6" deep (483 x 152 mm.)	45 3/4" x 4" deep (1162 x 102 mm.)	40 1/2" x 6" deep (1029 x 152 mm.)
Will cut off ... ..	16 1/2" x 3" deep (419 x 76 mm.)	26" x 3" deep (660 x 76 mm.)	20 1/2" x 5" deep (521 x 127 mm.)	46 3/8" x 3" deep (1181 x 76 mm.)	41 1/2" x 5" deep (1054 x 127 mm.)
Will cut off ... ..	17 1/2" x 2" deep (445 x 51 mm.)	27" x 2" deep (686 x 51 mm.)	21 3/8" x 4" deep (552 x 102 mm.)	47 1/4" x 2" deep (1200 x 51 mm.)	42" x 4" deep (1069 x 102 mm.)
Will cut off ... ..	18" x 1" deep (457 x 25.4 mm.)	27 3/8" x 1" deep (702 x 25.4 mm.)	—	48" x 1" deep (1219 x 25.4 mm.)	—
Will cut off when carriage is swivelled to 45°	—	—	13 1/4" x 7" deep (337 x 178 mm.)	—	30" x 7" deep (762 x 178 mm.)
" " " "	—	—	14 1/2" x 6" deep (378 x 152 mm.)	—	31 1/2" x 6" deep (800 x 152 mm.)
" " " "	9 3/4" x 5" deep (248 x 127 mm.)	15 1/2" x 5" deep (394 x 127 mm.)	15 3/8" x 5" deep (403 x 127 mm.)	32" x 5" deep (813 x 127 mm.)	32 1/2" x 5" deep (826 x 127 mm.)
" " " "	11 1/4" x 4" deep (286 x 102 mm.)	17 1/4" x 4" deep (438 x 102 mm.)	16 1/2" x 4" deep (422 x 102 mm.)	33 1/2" x 4" deep (851 x 102 mm.)	33 1/2" x 4" deep (845 x 102 mm.)
" " " "	12 1/8" x 3" deep (308 x 76 mm.)	18 1/8" x 3" deep (460 x 76 mm.)	17 3/8" x 3" deep (441 x 76 mm.)	34" x 3" deep (864 x 76 mm.)	34" x 3" deep (864 x 76 mm.)
" " " "	12 3/8" x 2" deep (327 x 51 mm.)	18 1/2" x 2" deep (479 x 51 mm.)	17 1/4" x 2" deep (451 x 51 mm.)	35" x 2" deep (895 x 51 mm.)	34 3/8" x 2" deep (873 x 51 mm.)
" " " "	13 1/4" x 1" deep (337 x 25.4 mm.)	19 1/4" x 1" deep (492 x 25.4 mm.)	18 1/4" x 1" deep (464 x 25.4 mm.)	35 1/2" x 1" deep (908 x 25.4 mm.)	37 3/8" x 1" deep (962 x 25.4 mm.)
Will straight groove up to 1 3/8" (41.2 mm.) deep ... ..	up to 10 1/2" wide (273 mm.)	up to 20" wide (508 mm.)	(not available)	(not available)	(not available)
Will groove when carriage is swivelled to 45° up to 1 3/8" (41.2 mm.) deep ... ..	up to 8" wide (203 mm.)	up to 14 3/4" wide (375 mm.)	(not available)	(not available)	(not available)
Maximum vertical rise and fall of saw ...	9 1/2" (241 mm.)	9 1/2" (241 mm.)	9 1/2" (241 mm.)	9 1/2" (241 mm.)	9 1/2" (241 mm.)
Speed of saw spindle in r.p.m. for 50 cycle electric supply ... ..	3000	3000	1500	3000	1500
<i>(Motor for Models C.D.1, 2 and 4 can be supplied for practically any Alternating or Direct Current supply. In the case of Models C.D.3 and C.D.5, motor is for two and three phase Alternating Current only.)</i>					
Diameter of saw spindle for saws ... ..	1 1/4" (31.7 mm.)	1 1/4" (31.7 mm.)	1 1/4" (31.7 mm.)	1 1/4" (31.7 mm.)	1 1/4" (31.7 mm.)
Horse power of motor ... ..	5	5	6	5	6
Overall length of each section of all-metal table to cut off up to 8' (2.4 m.) long using bar ... ..	8' 5" (2.56 m.)	8' 5" (2.56 m.)	8' 5" (2.56 m.)	8' 5" (2.56 m.)	8' 5" (2.56 m.)
<b>Machine only</b>					
Net weight ... ..	980 lbs. (444 Kilos)	1040 lbs. (470 Kilos)	1060 lbs. (482 Kilos)	1100 lbs. (495 Kilos)	1100 lbs. (495 Kilos)
Gross weight ... ..	1200 lbs. (546 Kilos)	1260 lbs. (571 Kilos)	1290 lbs. (584 Kilos)	1350 lbs. (609 Kilos)	1350 lbs. (609 Kilos)
Shipping dimensions in cubic feet ... ..	66 (1.86 cu.met.)	66 (1.86 cu.met.)	66 (1.86 cu.met.)	80 (2.26 cu.met.)	80 (2.26 cu.met.)
*Code Words: For alternating current ...	<b>Chacd</b>	<b>Cacud</b>	<b>Cucad</b>	<b>Colod</b>	<b>Civid</b>
For direct current ... ..	<b>Cidud</b>	<b>Cedid</b>	(not available)	<b>Cilid</b>	(not available)
<b>Machine with Metal Legs for Table</b>					
Net weight ... ..	1260 lbs. (571 Kilos)	1320 lbs. (596 Kilos)	1350 lbs. (609 Kilos)	1370 lbs. (622 Kilos)	1370 lbs. (622 Kilos)
Gross weight ... ..	1480 lbs. (673 Kilos)	1540 lbs. (698 Kilos)	1570 lbs. (711 Kilos)	1630 lbs. (736 Kilos)	1630 lbs. (736 Kilos)
Shipping dimensions in cubic feet ... ..	66 (1.86 cu.met.)	66 (1.86 cu.met.)	66 (1.86 cu.met.)	80 (2.26 cu.met.)	80 (2.26 cu.met.)
*Code Words: For alternating current ...	<b>Culed</b>	<b>Clegd</b>	<b>Cleed</b>	<b>Cofad</b>	<b>Cifed</b>
For direct current ... ..	<b>Calid</b>	<b>Cleid</b>	(not available)	<b>Calud</b>	(not available)
<b>With Metal Table</b>					
Net weight ... ..	1760 lbs. (800 Kilos)	1820 lbs. (825 Kilos)	1850 lbs. (838 Kilos)	(not available)	(not available)
Gross weight ... ..	2270 lbs. (1028 Kilos)	2330 lbs. (1054 Kilos)	2350 lbs. (1066 Kilos)		
Shipping dimensions in cubic feet ... ..	91 (2.57 cu.met.)	98 (2.77 cu.met.)	98 (2.77 cu.met.)		
*Code Words: For alternating current ...	<b>Citud</b>	<b>Catad</b>	<b>Cuted</b>		
For direct current ... ..	<b>Catid</b>	<b>Cetid</b>	(not available)		

\*When using code word, please state particulars of electric supply.

**Details included with each machine:** One motor complete with armoured cable to starter ; One pair of saw collars, hexagon nut and key ; One lubricating pump and sample tin of lubricant for ball bearings ; One starter ; Hinged aluminium saw guard ; Dust-collecting hood ; One set of spanners.



Saws

The saws used on Wadkin Cross Cutting and Trenching Machines run at a high peripheral speed, and it is therefore essential that they are correctly balanced and tensioned.

The saws we recommend and supply are manufactured specially for these machines from a high-grade alloy steel, are of the most suitable gauge for utility work, and correctly balanced and tensioned for high-speed running. The special shape and pitch of teeth has been developed to obtain clean cutting.

For a general purpose saw we recommend our 18" W.X.T. Flat Cross Cut Saw. For work demanding high-grade finish, our 18" W.X.T. Hollow Ground Cross Cut Saw is recommended.

*It is advisable that all saws used on these machines are obtained from us. No responsibility can be accepted when any other saws are used.*

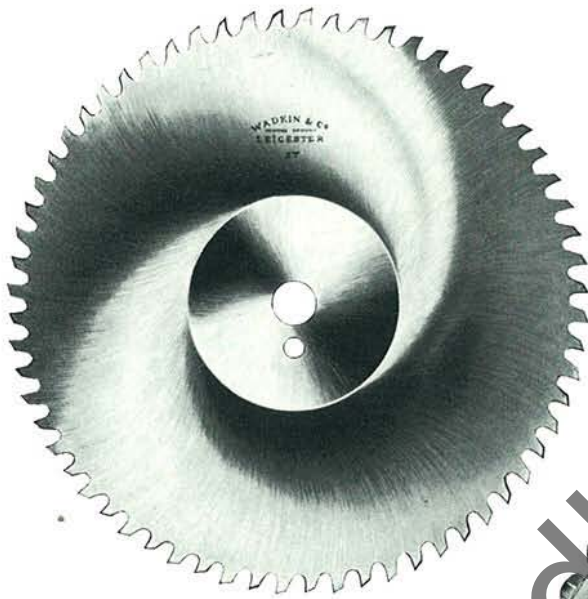

Expanding Grooving Heads,  
J.P. 468, 460, 464

The Head illustrated is accurately balanced and can be adjusted to cut grooves of any intermediate width within its range, and therefore a tight or loose joint can be made in the work. Each half is held in position on the shaft by a key and set screws.

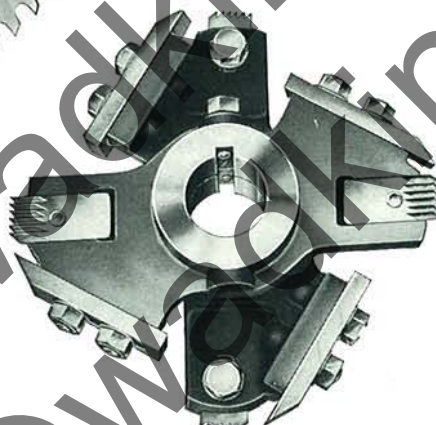

J.P. 468; 460; 464

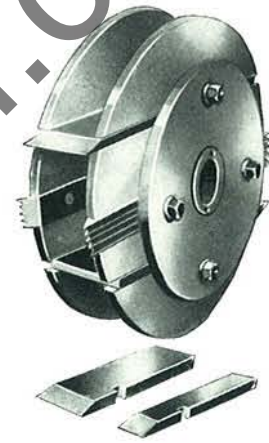

J.P. 215

The Heads are made in the following sizes:—

J.P.468.	11"	diameter cutting circle.	For grooves	$\frac{3}{8}$ " to $\frac{11}{16}$ "	wide up to	$\frac{9}{16}$ "	deep
J.P.460.	11"	"	"	$\frac{3}{8}$ " to $1\frac{7}{16}$ "	"	$1\frac{5}{8}$ "	"
J.P.464.	11"	"	"	$1\frac{3}{8}$ " to $2\frac{1}{2}$ "	"	$1\frac{5}{8}$ "	"

Grooving Head, J.P. 215

This Head is made up of two discs and is adjustable on a screwed bush to take cutters of varying widths. It is locked on the spindle by the spindle nut. The cutting circle is 11" diameter and will cut grooves  $\frac{1}{2}$ " to 2" wide by using varying width cutters. This Head will groove to a maximum depth of  $1\frac{1}{4}$ ".

Half Lapping and Bevelling Head,  
J.P. 502

This Head is supplied for use where a wide cut is required at the end of the timber as in half lapping. It can also be used for heavy birdsmoothing, as illustrated in the diagram on page 5. The Head has a cutting circle of  $6\frac{1}{2}$ " diameter and the cutters have a maximum width of  $4\frac{1}{2}$ ". A guard is supplied with this head.



J.P. 502

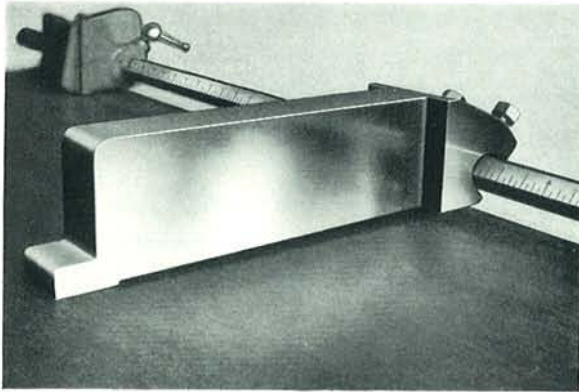

### Adjustable Fence for Multiple Cutting

This fence is designed to drop on to the graduated stop bar of the table, and is for use when several pieces of timber are to be cut at one operation. It is quickly set to give any required size and is attached or detached in a few seconds. Illustration showing this fence in use is on page 8.

When supplied for use on a 22½" wide metal table the fence extends the full width and can be locked at both front and back.

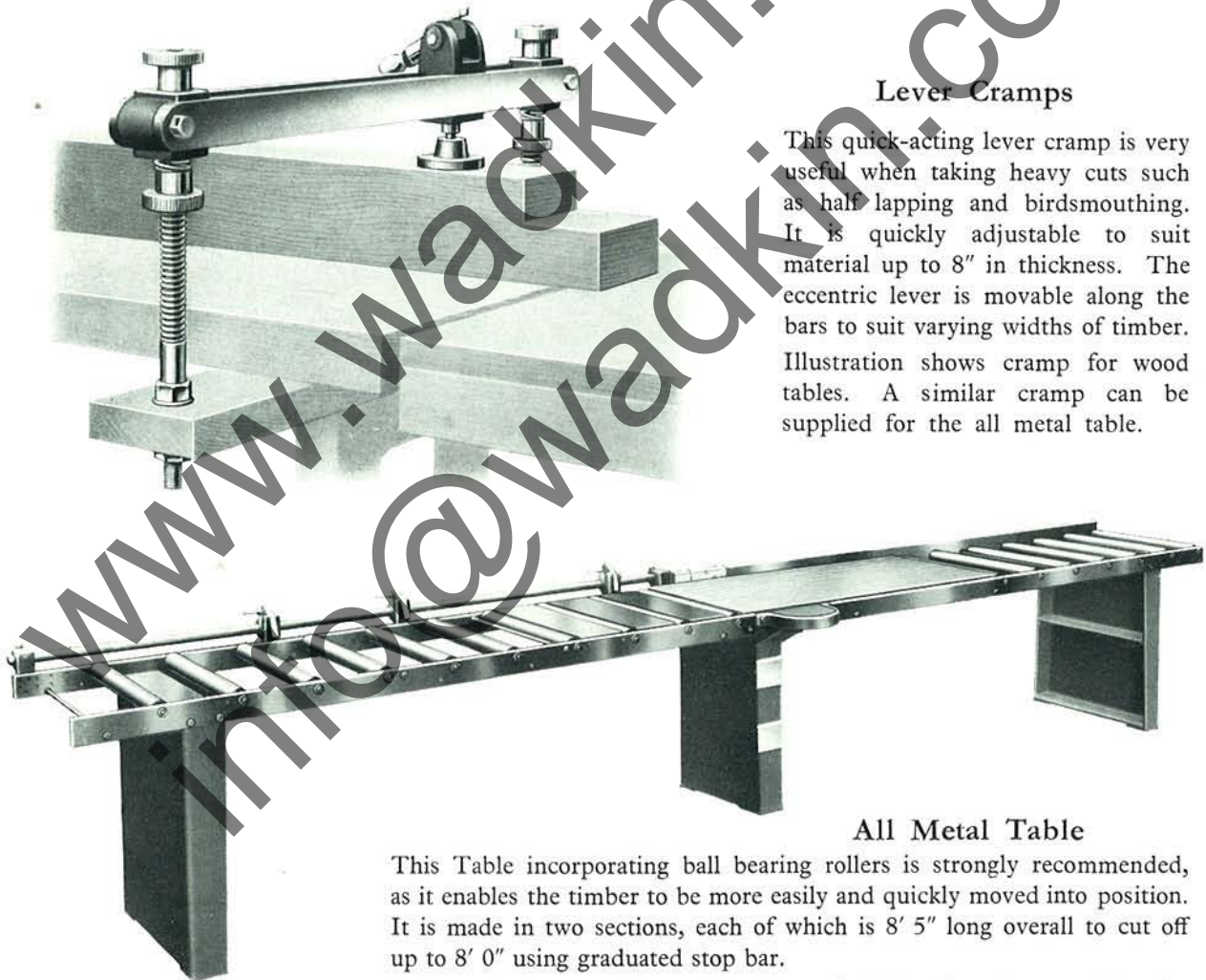

### Lever Cramps

This quick-acting lever cramp is very useful when taking heavy cuts such as half lapping and birdsmoothing. It is quickly adjustable to suit material up to 8" in thickness. The eccentric lever is movable along the bars to suit varying widths of timber. Illustration shows cramp for wood tables. A similar cramp can be supplied for the all metal table.

### All Metal Table

This Table incorporating ball bearing rollers is strongly recommended, as it enables the timber to be more easily and quickly moved into position. It is made in two sections, each of which is 8' 5" long overall to cut off up to 8' 0" using graduated stop bar.

It is made in two sizes 14½" wide and 22½" wide. To special order longer tables can be supplied in additional lengths of 4' 0". Tables should when possible be ordered with the machine.