

Edge banding machines Ambition 1420 - 1440



HOMAG Group

Success by partnership

To survive in a fiercely competitive market, a company has to have fast, flexible and efficient production.

The HOMAG Group, with its sales and service network in over 80 countries around the world, offers you and your employees a strong partnership no matter where you are.

The HOMAG Group of companies cover all areas of woodworking and wood-processing.

Panel sizing, sawing, edge technology, transportation technology and handling systems are just a few of our specialties.

We also offer solutions for drilling, coating technology, surface technology, plants for doors and doorframes, timber house construction, sanding technology, automation systems, packaging equipment and software.

We provide a complete and innovative range of products and services that are always the perfect solution for any requirement.

You, our customers, benefit from high precision, performance and cutting-edge technology.



**„With us, you and your products come first.
A promise that you can count on!“**

BRANDT

Perfect edges for demanding customers

We offer our customers innovative and powerful edgebanding machines. Efficiency and quality have the highest priority, and ensure long-term competitive advantages for you.

With an annual production of over 2000 edgebanding machines, we are the edgebanding specialist in the Homag Group and the world leader in our market segment.

A high degree of standardization in combination with an advanced manufacturing process and more than 50 years of engineering experience

ensure state of the art quality at a superb price-performance ratio. Our clear and structured product range is designed to meet the demands of current and future market trends. All of our developments are focused toward practically-oriented and economic solutions that guarantee you the best possible production results.

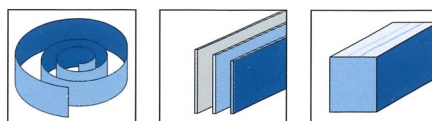
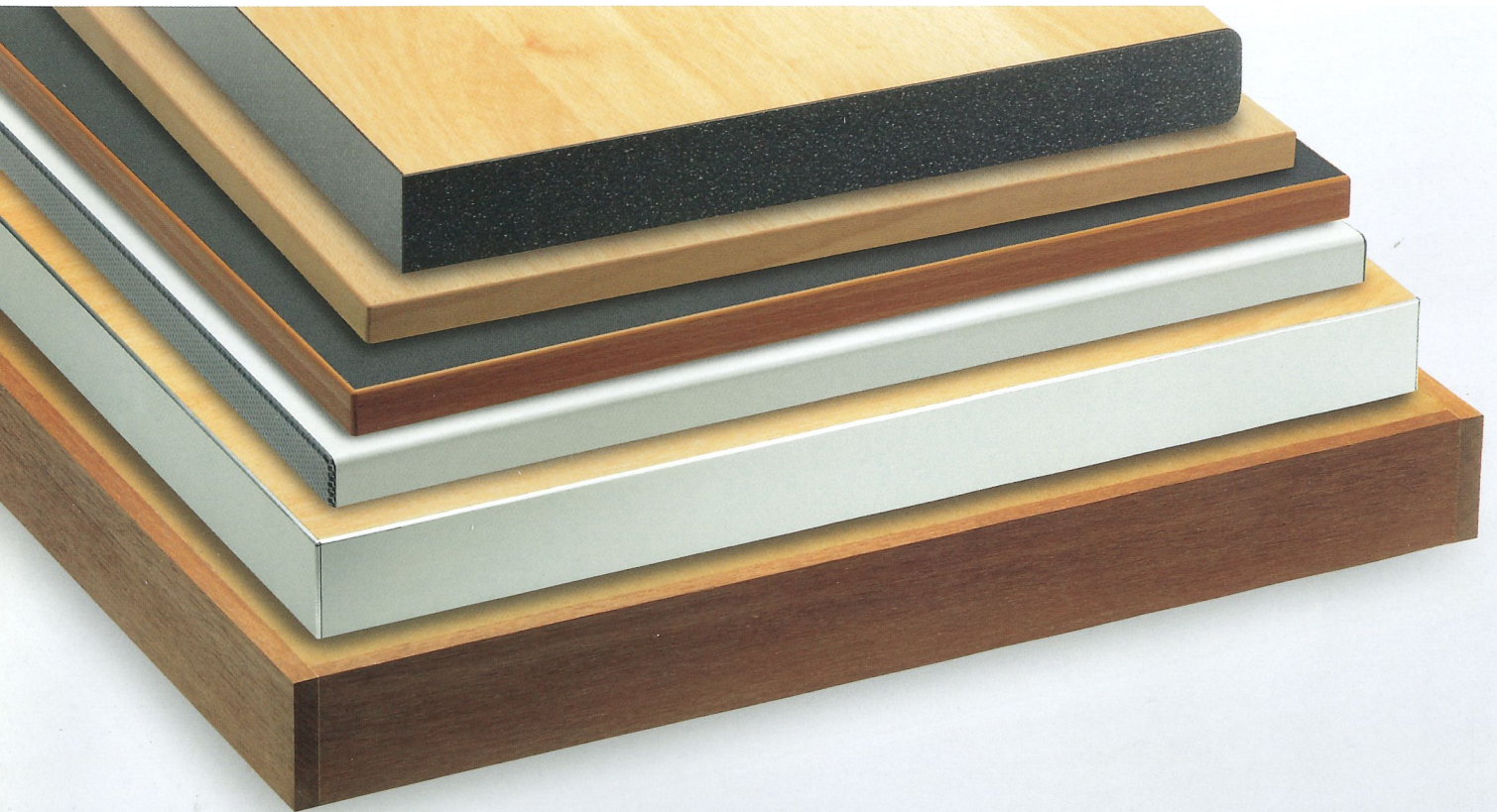

mm	Coil	Strips	Solid
a		min. 70	
b		8 - 60	
c		0,4 - 8	
d		65	
e		max. 30	

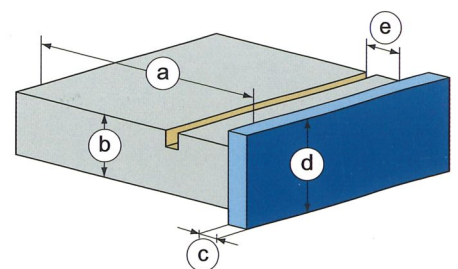

„Ideal prepared for your requirements“

Ambition 1420 - 1440 FGC

The powerful compact class

Perfect for the craftsman, as well as small and medium-sized enterprises, the ambition 1400 series provides long-term competitive advantages. In the standard version, the machine is equipped with a precision gluing unit, a tiltable end trimming unit, a multi-functional top/bottom trimming unit, a radius scraper and a buffing unit. Depending on requirements, the machine can also be equipped with separation and detergent agent spraying units, a joint trimming unit, a Quick-melt gluing unit for more efficient production, a rough trimming unit for

heavy trimming, a contour trimming unit for corner rounding, a grooving unit and a glue joint scraper. The feed speed is 11 m / min. which can optionally be increased to 14 m / min. without compromising the performance of the contour trimming unit. The optionally available automation packages shorten the setup time and provide a higher level of operational convenience.

The right solution for your requirements

The Ambition 1400 series machine leaves nothing lacking. Whether your needs are a demanding shop setting, "batch size one" production for custom requests, living & bedroom furniture or functional office furniture, the Ambition 1400 Series always offers the right solution for your requirements.

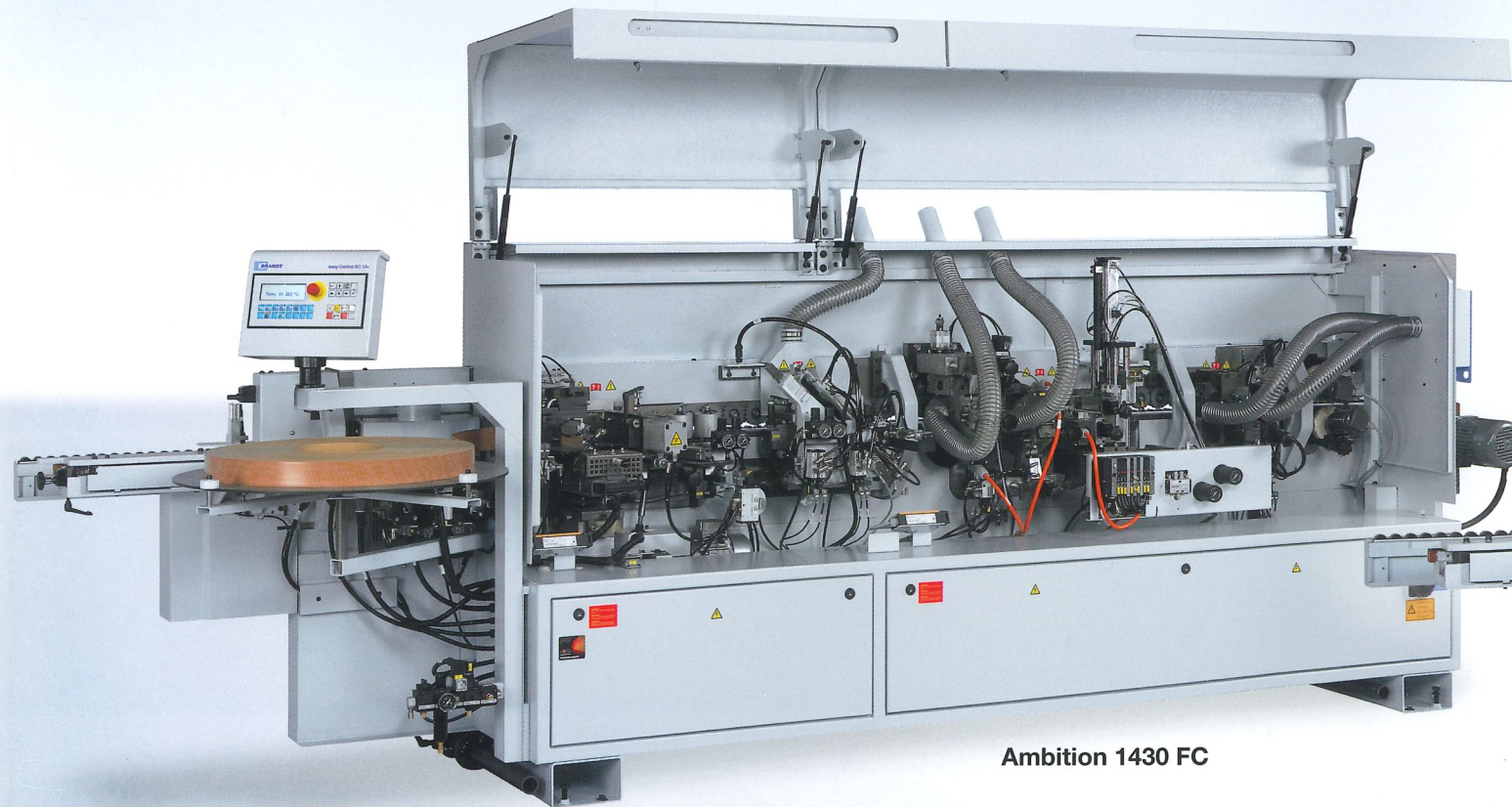

Ambition 1430 FC



Ambition 1420

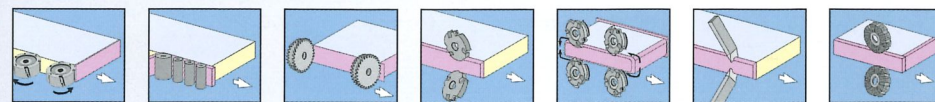

The controller – Quality and precision with the touch of a button

Through targeted and constant development of controller technology, simple operation and a high operating comfort are guaranteed.

At BRANDT we focus on you as our customer and your finished product.



EasyControl EC 10+, offering every "plus" for the customer

- + High operating convenience through simple menu format and optimized linepoint adjustment.
- + Fast access to all unit functions through dedicated control buttons.
- + Quick change over to different edgbanding material through user-defined programs.
- + Easy to read large 4-line operating display
- + Clear text error diagnostics provide high operating convenience



powerControl PC 20+ (Ambition 1440er)

- + Optimum overview by using a big 12" screen
- + High operator comfort with all functions button-controlled from the operating panel
- + Short set up times, through high controller capacity and easy selection of processing programs
- + Self-explanatory operator guidance, through a graphic interface and optimum visualisation
- + Easy Back-up function of the entire control and all operator programs

- + Network-compatible
- + Context-sensitive help - detailed information about the functions and how to operate the machine directly on the screen
- + Compilation of production data for detailed gathering of job related costs

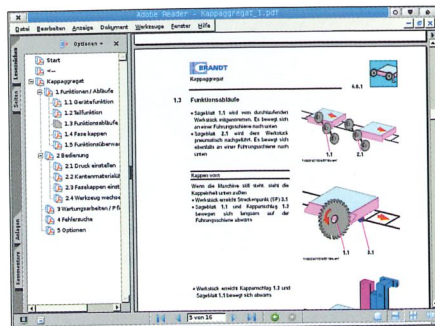

Context-sensitive help

With the context-sensitive help function, it is possible to directly display detailed information on the operations and functions of the machine. The controller-integrated help functions are accessible with the push of a button from the keyboard and allow for immediate operator support.

Datum		16.03.2009											
Uhrzeit		13:14:59											
Konnotation		Kommision Test Knechten											
Bediener		SH											
Zusatz Info		Kommentar:											
Programm		Programm 1											
Datum		16.03.2009	16.03.2009	16.03.2009	16.03.2009	02.04.2009	03.04.2009	03.04.2009	03.04.2009	03.04.2009	03.04.2009		
Startzeit		13:16:24	13:21:14	13:29:02	13:31:38	09:11:46	09:44:17	07:58:14	07:58:35	07:58:35	07:58:35		
Stopzeit		13:20:27	13:25:45	13:30:45	13:33:18	09:12:58	10:24:34	07:58:32	07:58:39	07:58:39	07:58:39		
Tages Brunden		0.02	0.08	0.02	0.01	0.00	0.00	0.00	0.00	0.00	0.00		
Tages Werkstücke		18.0	0.0	0.0	14.0	0.0	0.0	0.0	0.0	0.0	0.0		
Tages Kontrollrate		0.1	0.0	0.0	0.0	0.0	0.0	0.0	0.0	0.0	0.0		
Programm		Programm 2hc											
Datum		16.03.2009											
Startzeit		13:20:29											
Stopzeit		13:21:11											
		P1	P2	P3	P4	P5	P6	P7	P8	P9	P10	P11	P12

Compilation of production data via the BRANDT-Browser

Compiled production data can be easily gathered and saved.

The BRANDT-Browser allows for job-specific collection of operating hours, an overview of the total processed workpieces and information regarding total meters of processed edges.

For companies that have large numbers of different clients, it is especially advantageous to always have an accurate record of contract-related costs.

Significant competitive advantages – Pace setting performance and quality

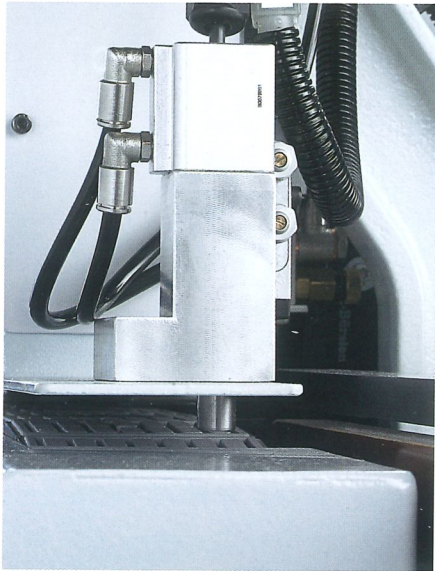

Infeed stop

For minimum workpiece spacing and safe operation.



Joint trimming unit

Perfect cut and high operating life due to diamond tipped tools for an optimum edge joint quality.



Radiant heater

Strong adhesion through optimal pre heating of the workpiece.



Grooving unit

For grooving of drawers or back walls.



Multifunctional trimming unit (Ambition 1440 FC)

Trimming of the edge overhang on top and bottom side as well as contour trimming on the front and rear edges. Equipped with an automatic adjustment to switch between thick and thin edges. Workpiece thickness up to 60mm.

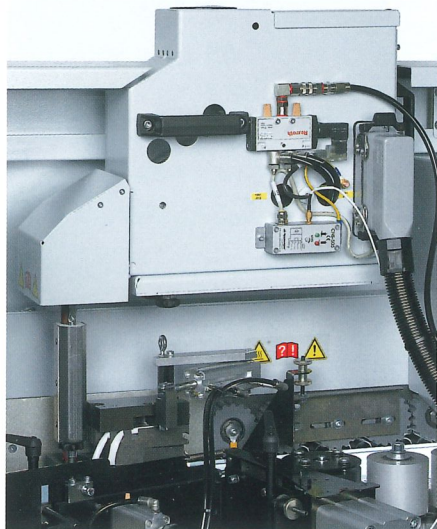
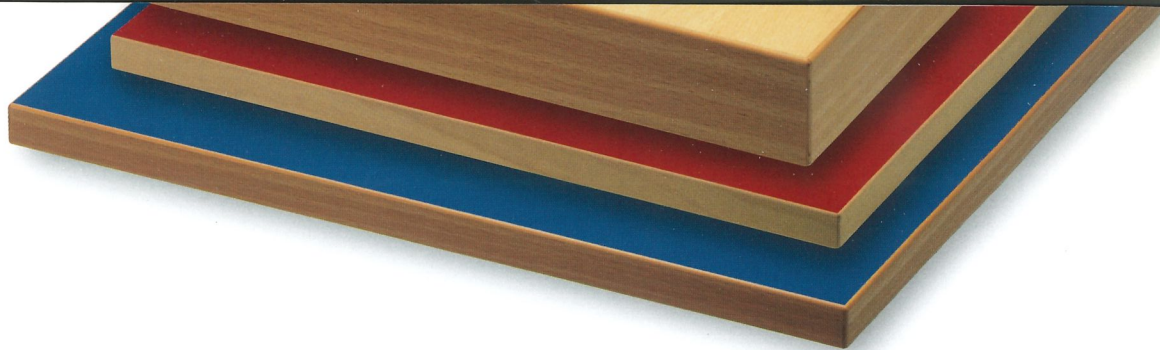

**Pre-melter
(optional)**

On-demand availability and perfect glue quality with Quickmelt.

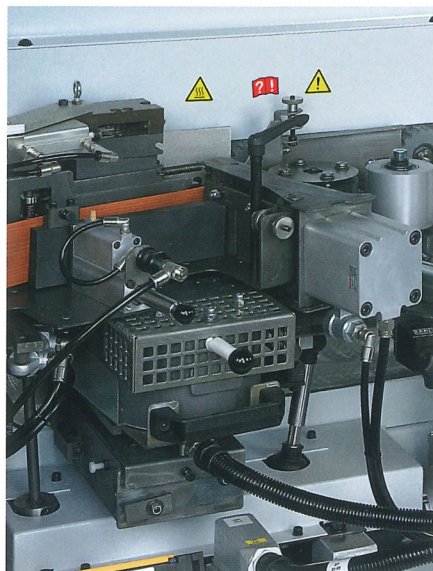

Magazine

Coil and automatic strip magazine for a reliable material supply.



Pressure zone

Heavy pressure zone up to 8mm edge thickness and 60mm workpiece height for an optimal glue joint.

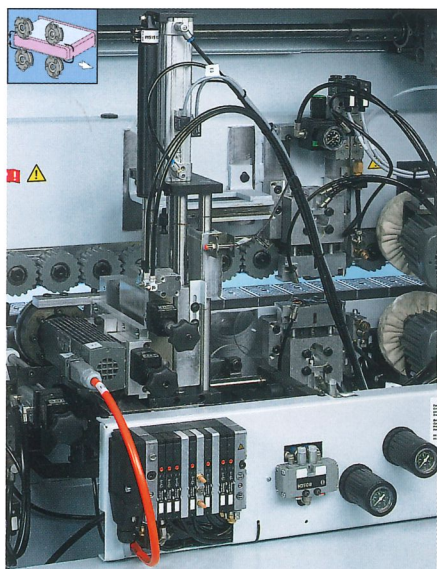

Corner rounding unit

Optimum corner rounding without adjustment or set-up, resulting from the coupled DIA tool and tracer roller.

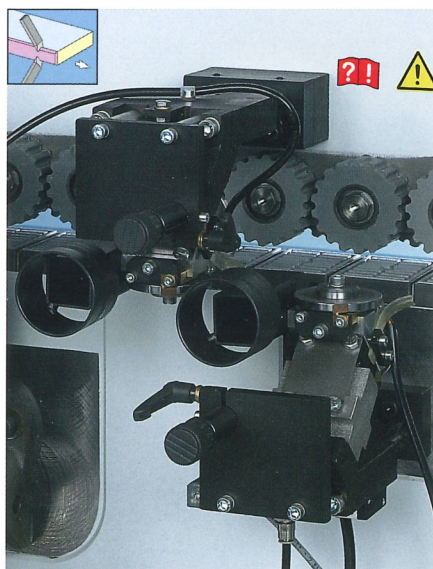

Profile scraping unit

To smooth radii or chamfers.

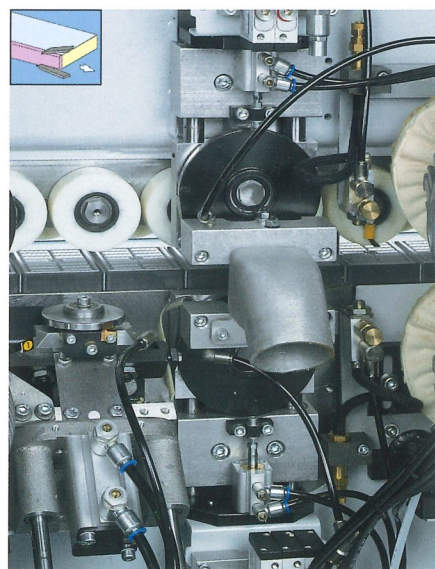

**Glue joint scraping unit
(optional)**

For the perfect finish and for edge scraping up to 0,3mm.

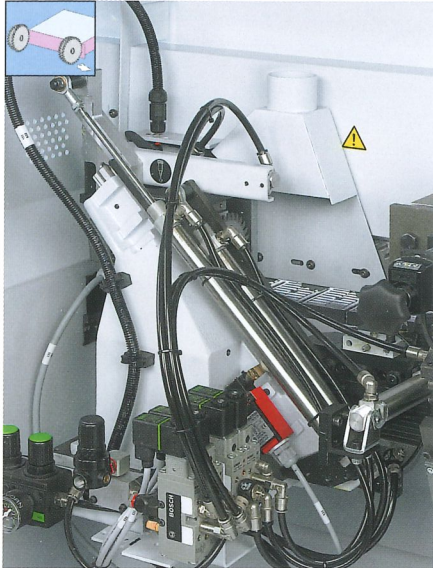

End-trimming unit

Precise end-cut through a strong end-trimming unit, equipped with THK guides

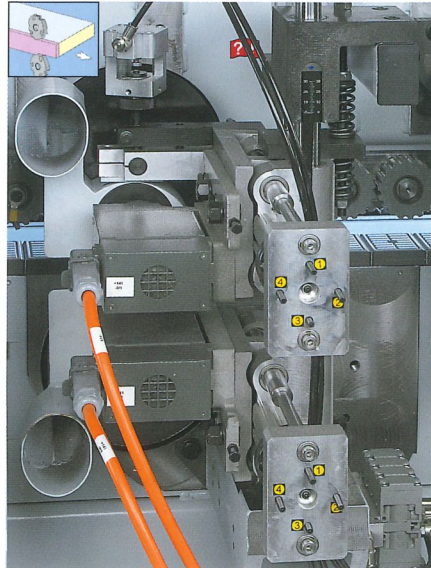

Rough trimming unit

For rough trimming of all common edgebanding materials.

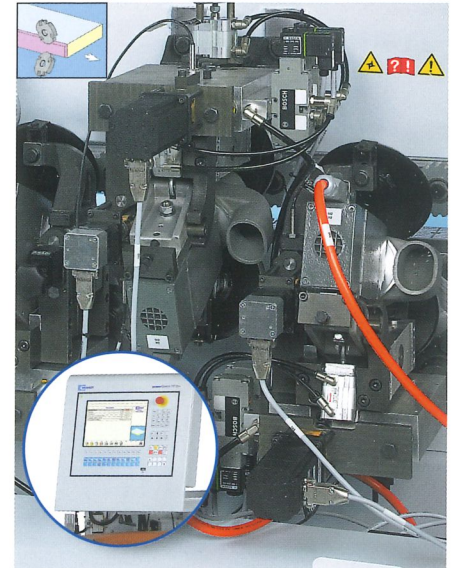

Multifunctional trimming unit (optional)

Flexible adaptation to different edge thicknesses and profiles through servo axes.



Buffing unit

Buffing unit to polish edges and maintain their natural color.

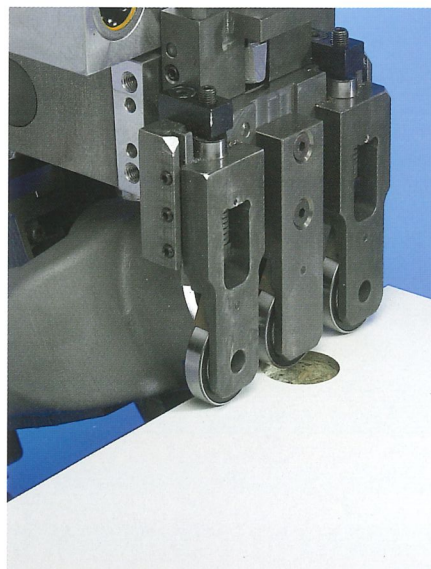

Nesting package (optional)

Includes a multi-roller tracing device for the trimming and scraping units to compensate for hinge holes.



Central lubrication unit

To lubricate the feed track guidance system to guarantee precision and a long life of the conveyor chain.

Technical data



Ambition 1420 F

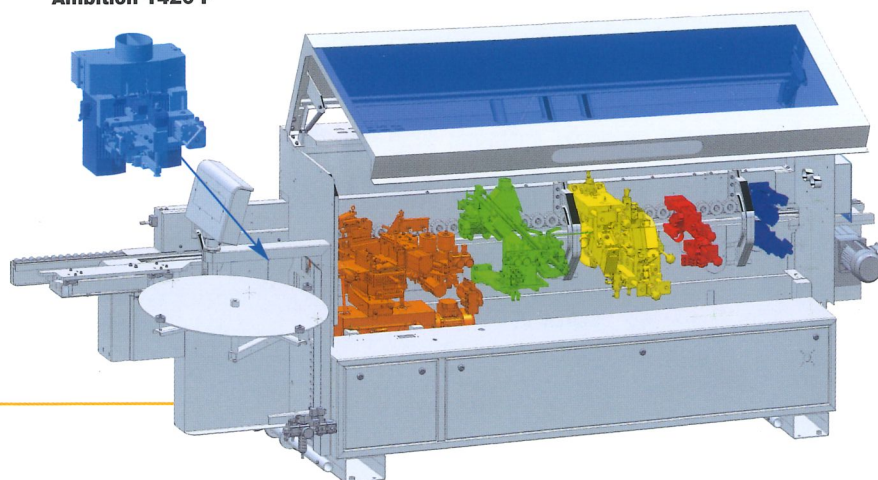
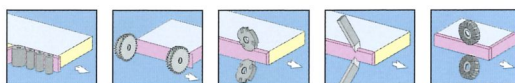

Ambition 1420
Ambition 1420 F



Ambition 1430 FC

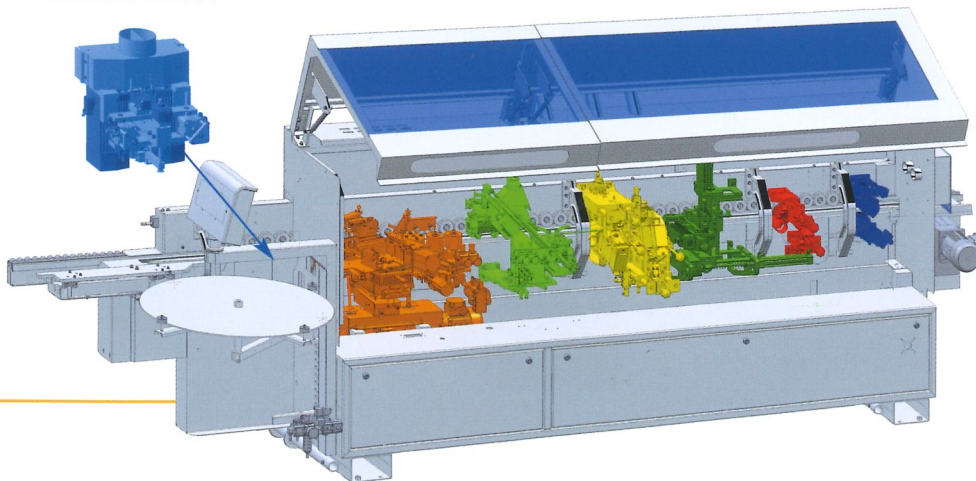
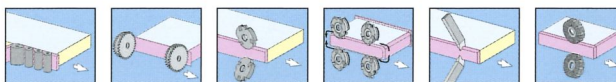

Ambition 1430 C
Ambition 1430 FC

	Ambition 1420	Ambition 1420 F	Ambition 1430 C	Ambition 1430 FC
Machine dimensions				
Machine length (mm)	4270	4270	4770	4770
Working height (mm)	950			
Machine dimensions WxH (mm)	1130 x 1580			
Working dimensions				
Workpiece thickness (mm)	8 - 60			
Edge material thickness (mm)	0,4 - 8			
Miscellaneous				
Feed speed (m/min)	11 (optional 14)			
Weight (kg)	1350	1410	1630	1690
Connected value (kW)	6	10	6	10,5
Extraction diameter (mm)	3x60/1x100	1x120/3x60/1x100	3x60/1x100	1x120/3x60/1x100
Electrics	400 V - 3 Ph - 50 Hz			
Pneumatics (bar)	6			

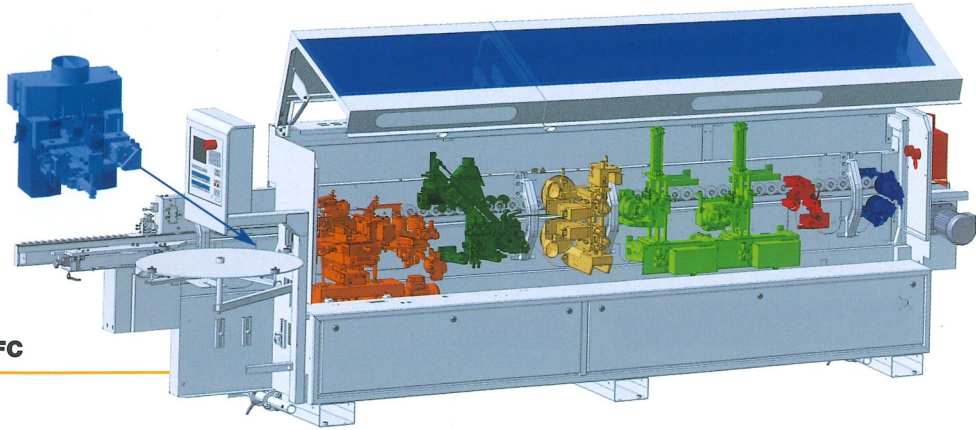
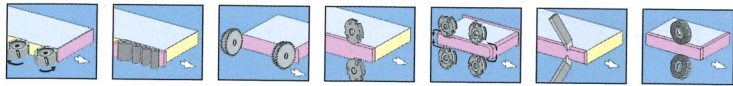

Ambition 1440 FC

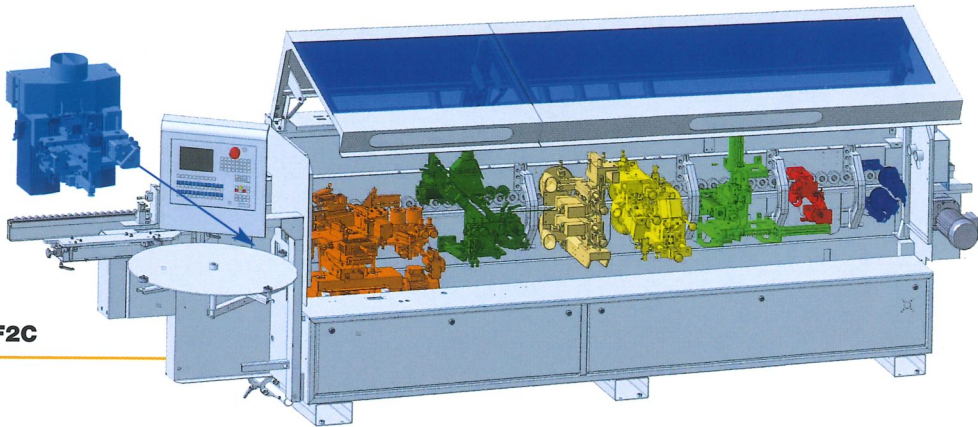
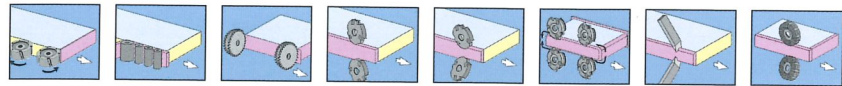

Ambition 1440 F2C

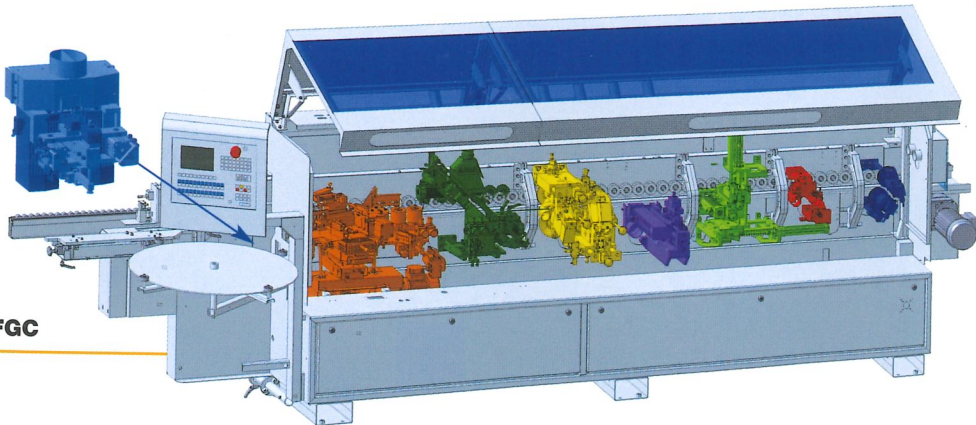
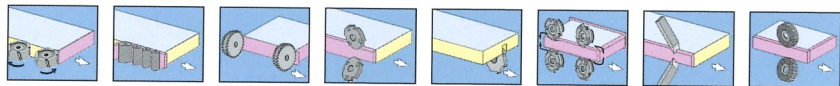

Ambition 1440 FGC

	Ambition 1440 FC	Ambition 1440 F2C	Ambition 1440 FGC
		Machine dimensions	
Machine length (mm)		5270	
Working height (mm)		950	
Machine dimensions WxH (mm)		1130 x 1580	
		Working dimensions	
Workpiece thickness (mm)		8 - 60	
Edge material thickness (mm)		0,4 - 8	
		Miscellaneous	
Feed speed (m/min)		11 (optional 14)	
Weight (kg)		1850	
Connected value (kW)	14,5	13,5	14,3
Extraction diameter (mm)	1x120/1x60/2x80/2x60/1x100	1x120/1x60/2x80/2x60/1x100	1x120/3x60/1x80/1x100
Electrics	400 V - 3 Ph - 50 Hz		
Pneumatics (bar)	6		

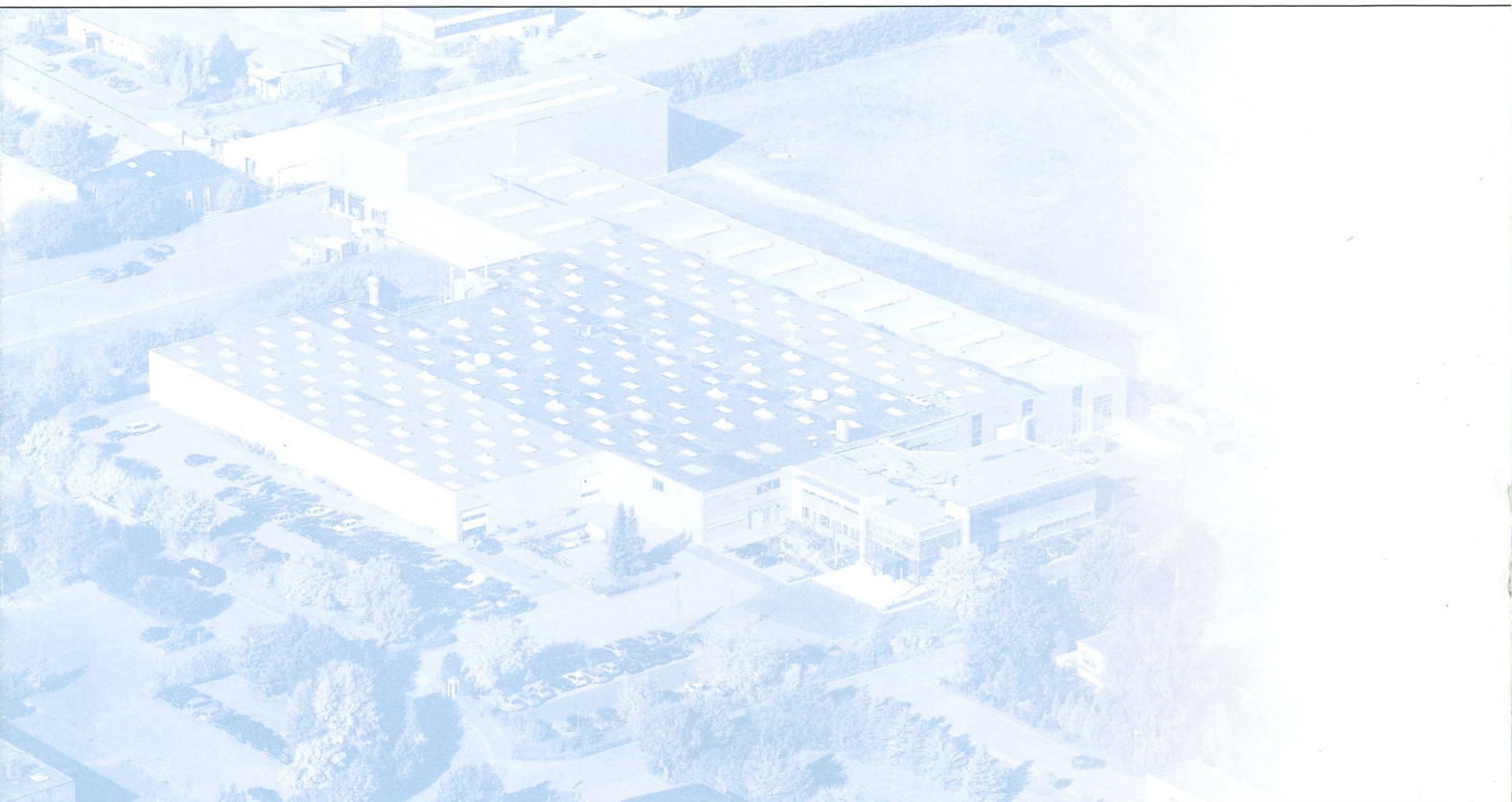

A member of the Homag Group of Companies



BRANDT
Kantentechnik GmbH
Weststraße 2
32657 Lemgo
Germany
Tel. +49 5261/974-0
Fax +49 5261/6486
info@brandt.de
<http://www.brandt.de>

