

rx

S E R I E S

RAPID

8

9

10

11

12

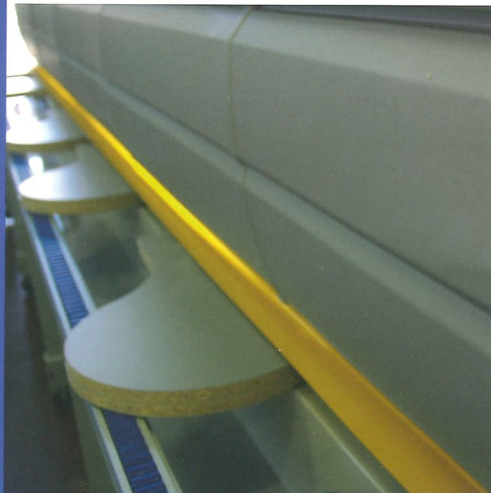
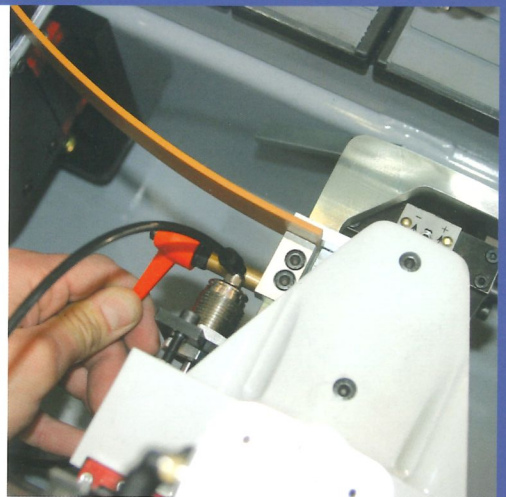

Freivol

Bordatrice
Edge Bander



rx9

rx10

STYLE | & | TECHNOLOGY

I Macchina Bordatrice

- Macchina Bordatrice automatica per l'applicazione di bordi in PVC, ABS, melaminico, impiallacciatura, masselli, in strisce o rotolo.
- Macchina compatta e robusta.
- Ideale per l'industria e l'artigianato.
- Avanzamento variabile da 10 - 20 mt/min.
- Rapida nel riscaldamento; la partenza avviene in 6 ÷ 8 minuti
- Sui modelli RX 8-12 si possono applicare dei gruppi accessori.

GB Edge-Banding Machine

- Single automatic edging machine for application of PVC, ABS, melamine, veneer and solid wood edges in strips or rolls.
- Compact sturdy machine. Ideal for industrial or artisan use.
- Adjustable feed from 10 - 20 mt/minutes.
- Quick heating, start-up 6 ÷ 8 minutes.
- Glue pot capacity: Kg. 3
- The units are adjusted automatically with pressure bar provided with a double row of wheels.
- The two end-trimmer motors are adjustable from 0° ÷ 15° both are powered by a 200 Hz frequency inverter.
- The RX 8-12 can be fitted with the following accessories units.

F Encolleuse de Chants

- Machine Encolleuse automatique pour l'application de chants en PVC, ABS, mélaminé, plaqué, massif, en bande ou rouleau.
- Machine compacte et robuste.
- Idéale pour l'industrie et l'artisanat.
- Avancement variable de 10 - 20 ml/min.
- Rapide dans l'échauffement, la partie arrive en 6 ÷ 8 minutes.
- Capacité du bac à colle: 3 Kg.
- Groupes presseurs réglable automatiquement composé de deux rangées de roulettes.
- Deux moteurs de l'installation sont réglables de 0° ÷ 15°; les deux sont alimentés d'un inverter de fréquence à 200 Hz.
- Sur le modèles RX 8-12 peuvent s'appliquer des groupes accessoires.

D Kantenanleimmaschine

- Automatische Kantenanleimmaschine für das Anleimen und Nachbearbeiten von PVC-ABS-Melamin-und Furnierkanten als Streifen-oder Rollenware und Massivholzkanten.
- Kompakte und stabile Maschinenbauweise.
- Der ideale Automat für den Industriebetrieb und die Möbelwerkstätte.
- Vorschubgeschwindigkeit stufenlos bis 10 - 20 mt/Min.
- Schnellheizbecken, Aufheizzeit max. 6 ÷ 8 Minuten.
- Leimbeckeninhalt ca. 3 Kg.
- Obendruckwerk mit doppelter Reihe von Druckrollen, gleichzeitig Höhenversstellung der oberen Nachbearbeitungsaggregate mit dem Obendruckwerk.
- Die beiden Motoren des Kappaggregates sind horizontal von 0° ÷ 15° schrägstellbar, der Antrieb erfolgt über einen Inverter 200 Hz.
- Bei den Automaten der Modellreihen RX 8-12 können zusätzliche Nachbearbeitungsaggregate aufgebaut werden.

E Encoladora de Canto

- Máquina automática para el encolado de cantos en PVC, ABS, melamina, madera, en tiras o rollos.
- Máquina compacta y robusta.
- Ideal para la industria y el pequeño taller.
- Avance variable 10 - 20 mt/min.
- Calentamiento rápido de 6 ÷ 8 minutos.
- Capacidad del depósito de cola: 3 Kgs.
- Grupos regulados automáticamente con barra prensora con doble fila de ruedas
- Los dos motores del retestador son regulables de 0° ÷ 15° grados; ambos son alimentado por un inverter de 200 Hz.
- Posibilidad de adaptación de los siguientes accesorios en los modelo RX 8-12.

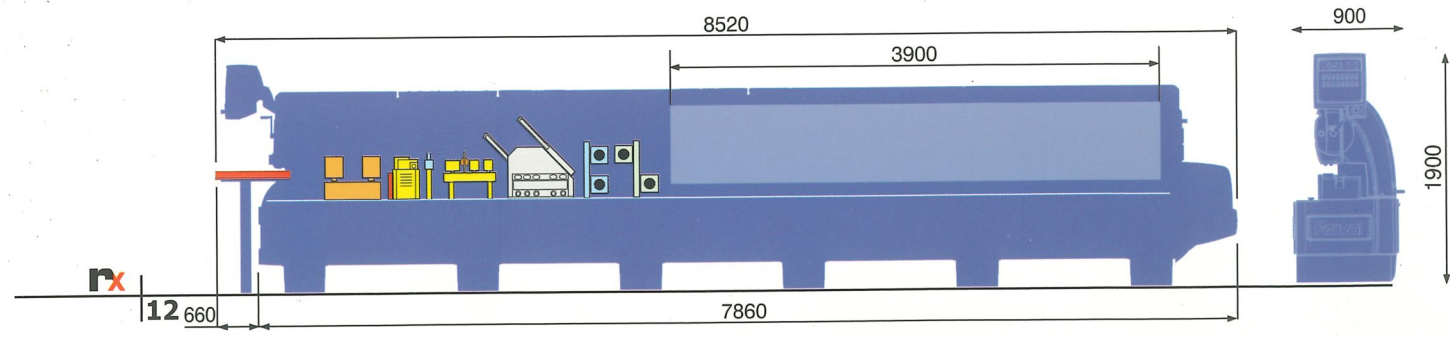
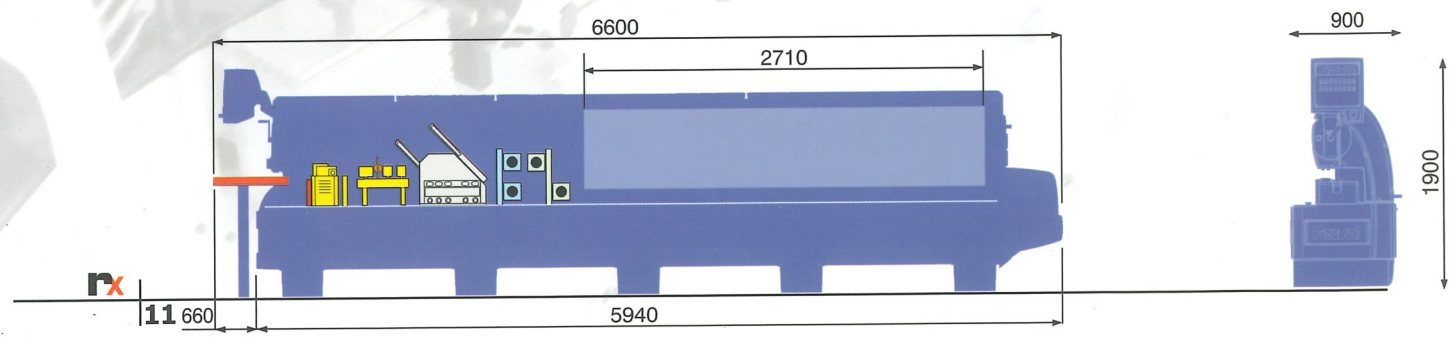
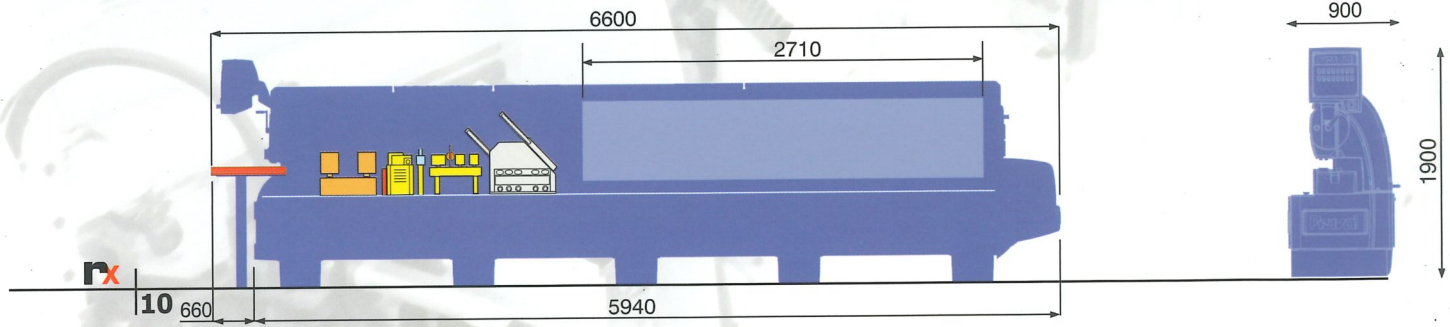
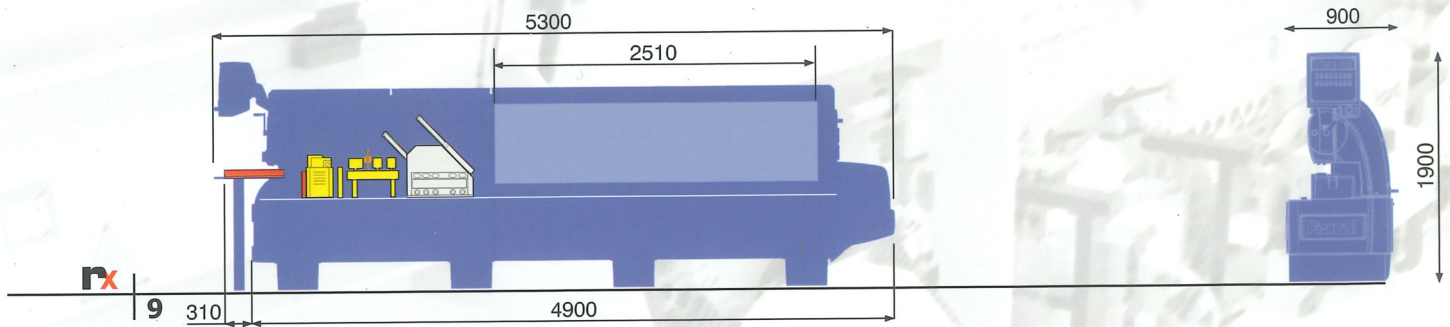
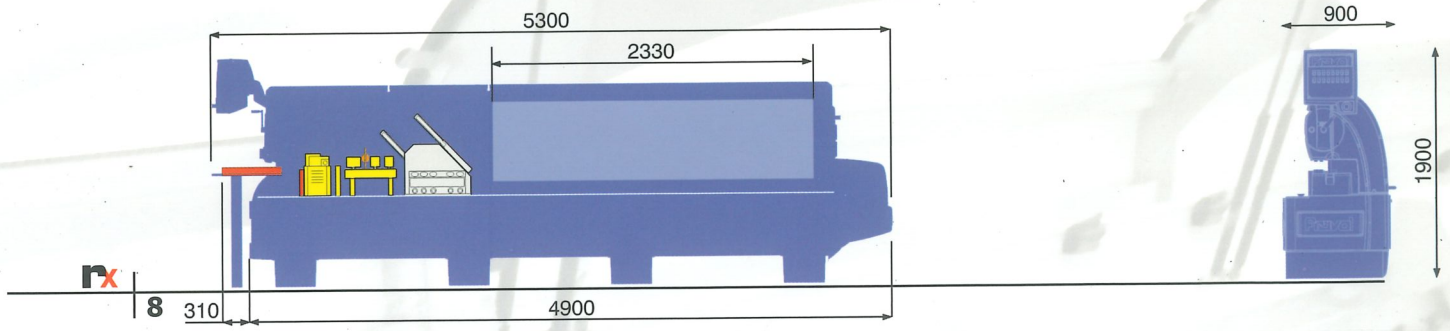

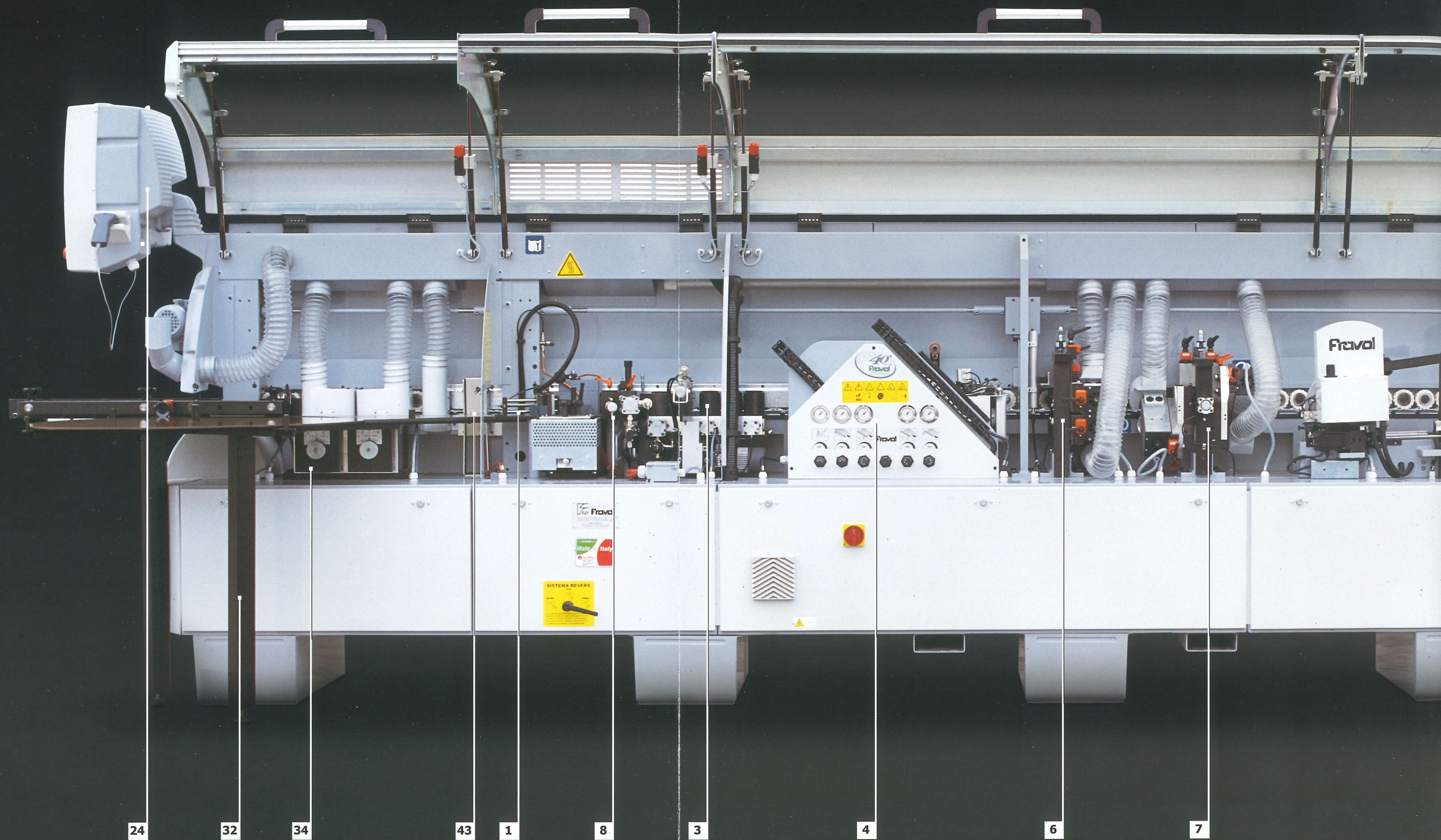

24

32

34

43

1

8

3

4

6

7

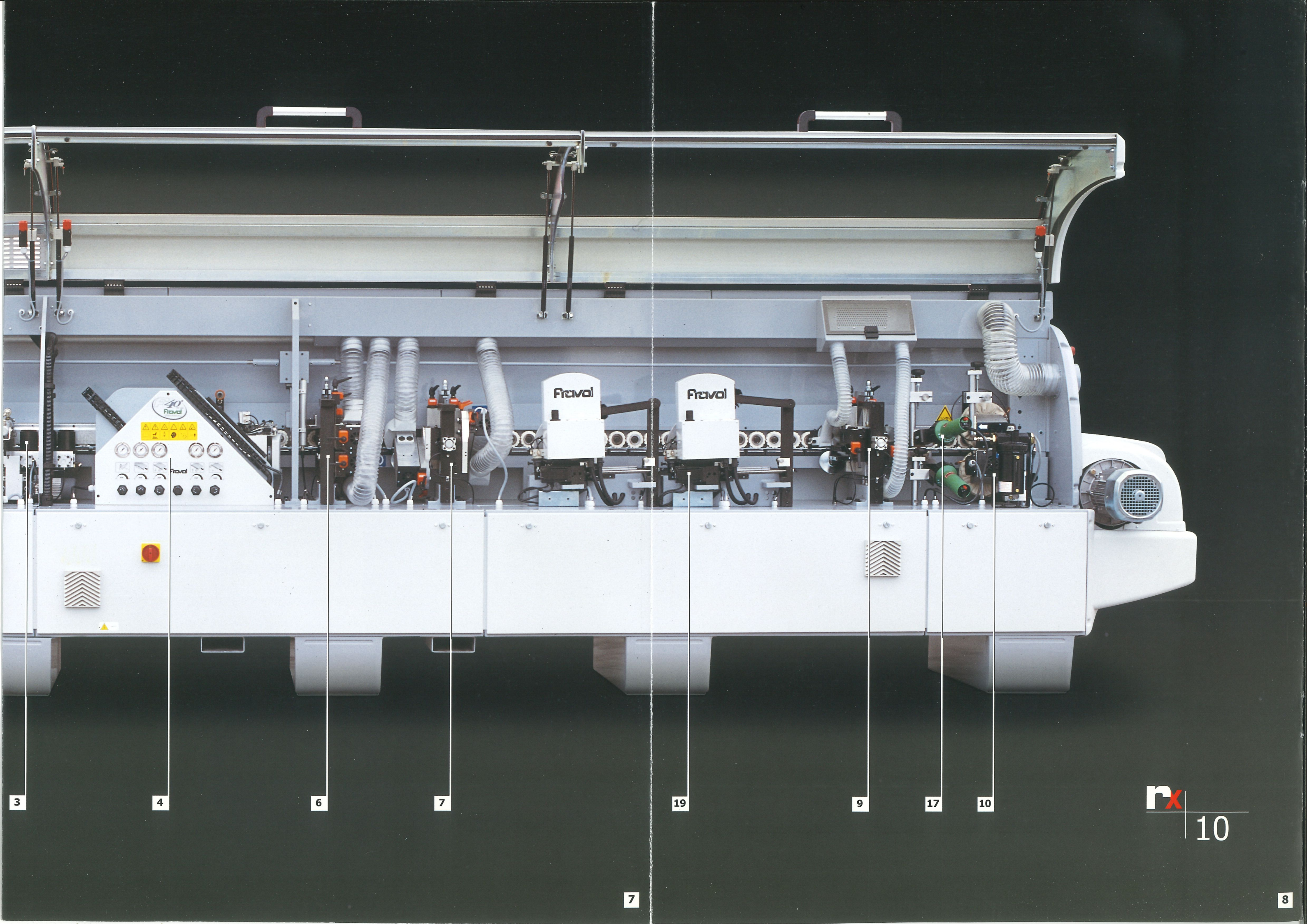

3

4

6

7

19

9

17

10

7

rx

10

8

34



- I Toupie in entrata
- GB Pre-Milling Unit
- F Toupie en entrée
- D Füge-Fräsggregat am Maschinenleinlauf
- E Toupie en entrada

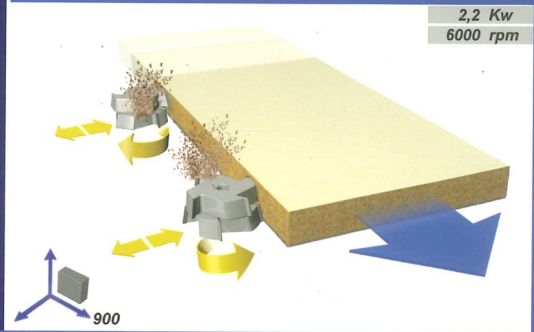

24



- I Controllo con microprocessore (P.L.C.)
- GB Microprocessor control (P.L.C.)
- F Contrôle avec microprocesseur (P.L.C.)
- D Mikroprozessor-Steuerung (S.P.S.)
- E Control con microprocessador (P.L.C.)

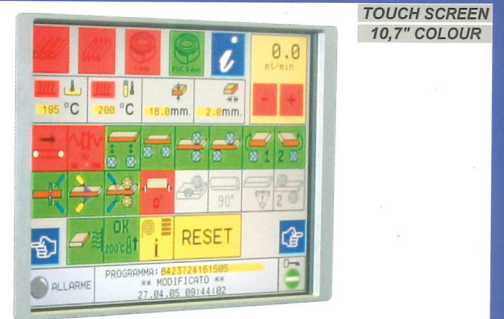

1

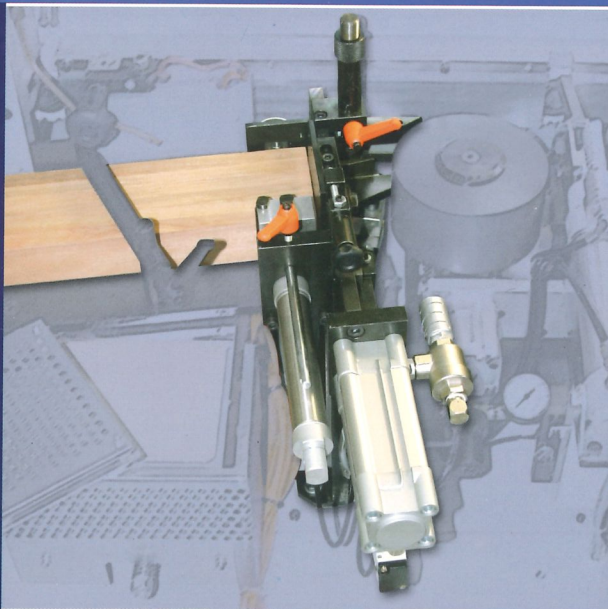

- I Caricatore automatico bordi
- GB Edge-Feeding
- F Charger le chant
- D Kante zuführen
- E Alimentacion del canto

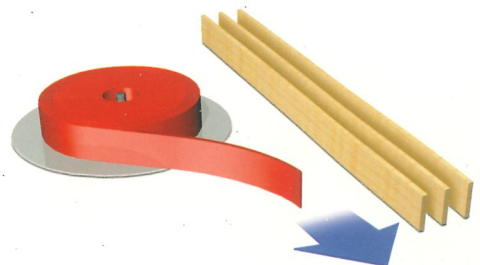

8

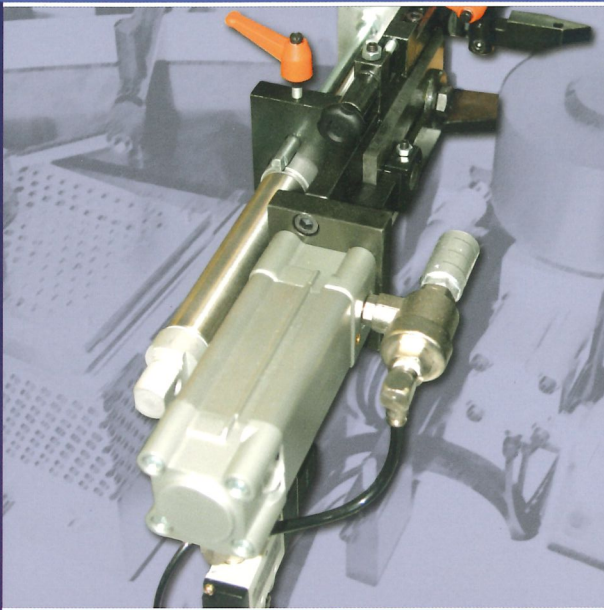

- I Taglio del bordo in rotolo - 3 mm - PVC/ABS
- GB Guillotine for PVC/ABS - 3mm
- F Coupe du chant en rouleau - 3 mm - PVC/ABS
- D Rollentrennen - 3 mm - PVC/ABS
- E Corte del canto en rollo - 3 mm - PVC/ABS

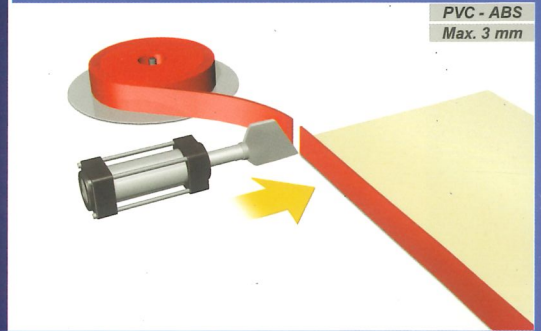

3

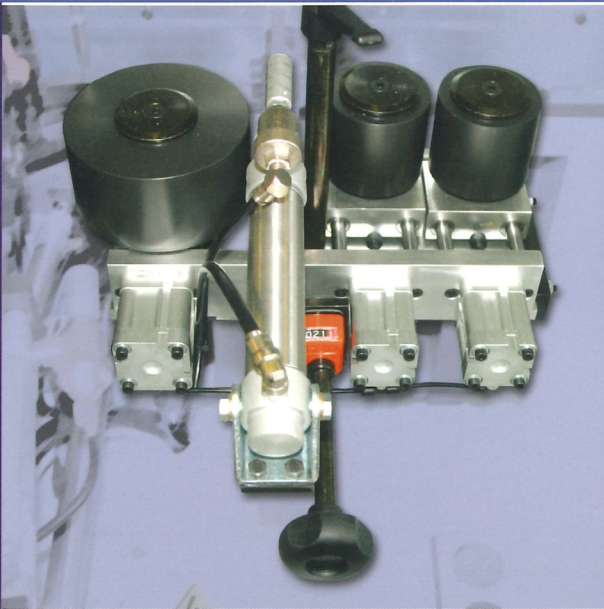

- I Incollaggio
- GB Pressure Zone
- F Encollage
- D Anleimen
- E Encolado

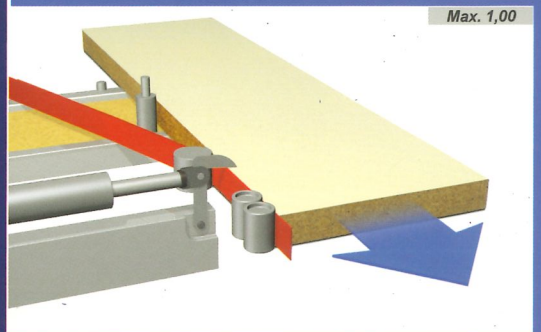

4



- I Intestatore
- GB Two Motors End-Trim
- F Abouters
- D Kappen
- E Retestador

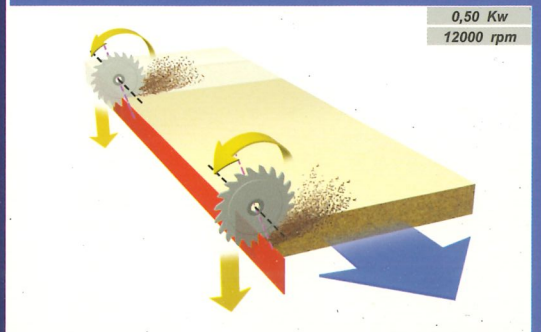

5

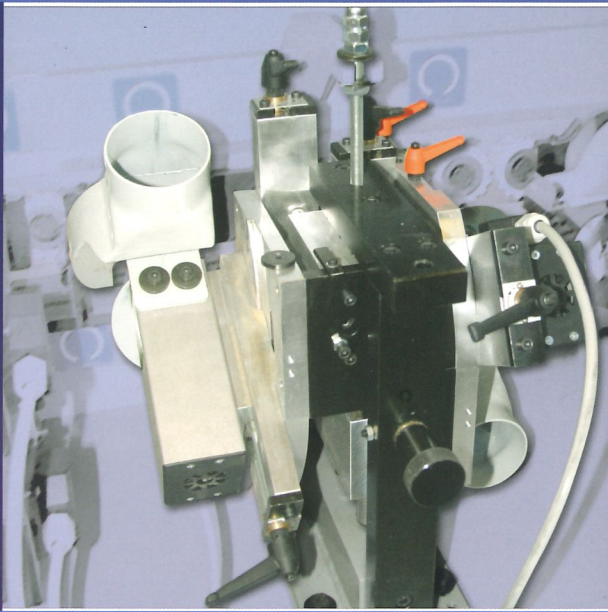

- I Rifilatore inclinabile
- GB Heavy Duty Bevel Trim Unit
- F Dégrossés
- D Vorfräsen (Planfräsen)
- E Desbastador

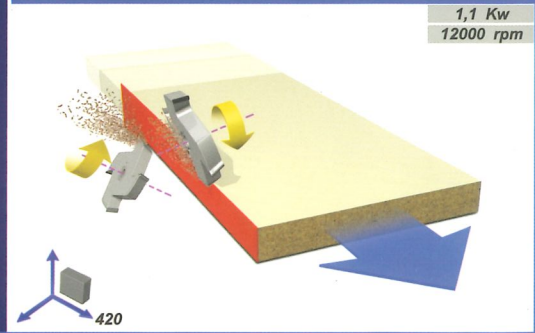

6

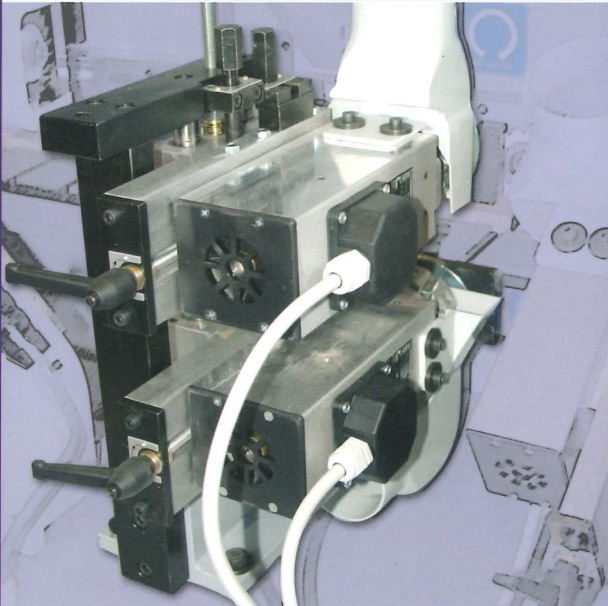

- I Rifilatore sovrapposto
- GB Top-Bottom Roughing Unit
- F Dégrossés
- D Vorfräsen (Planfräsen)
- E Desbastador

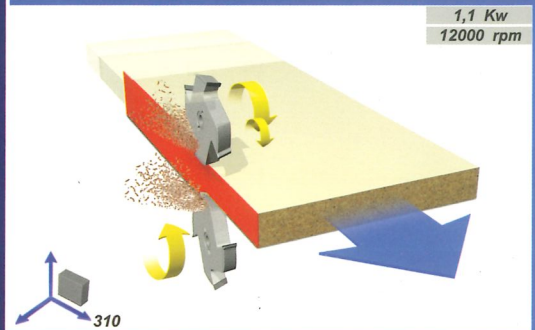

7

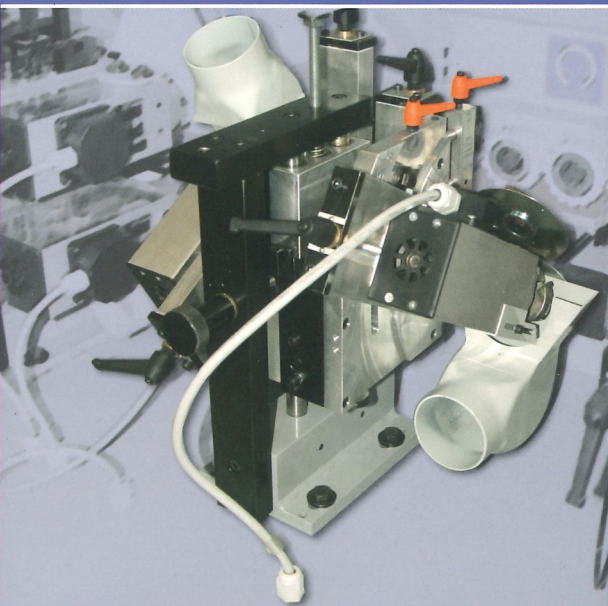

- I Spigolatore
- GB Fine-finish Bevel Trim Unit
- F Superfinition
- D Feinfräsen
- E Acabado fino

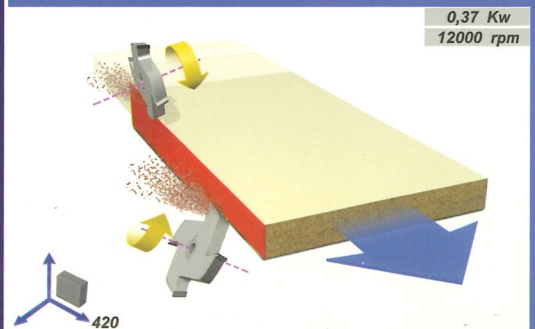

19

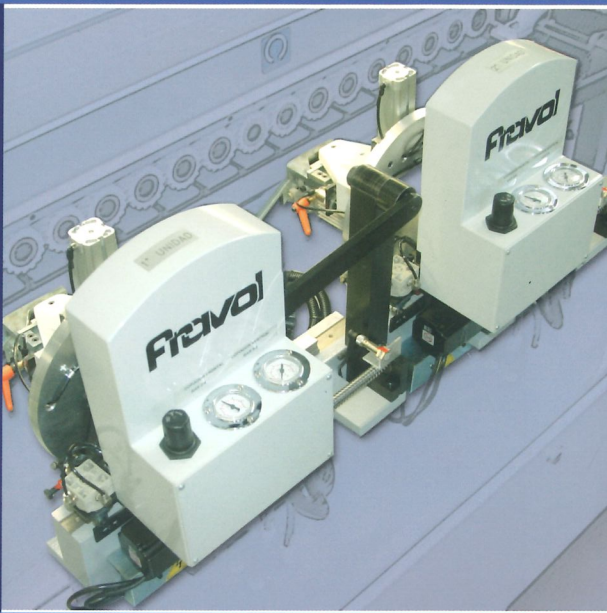

- I Arrotondatore
- GB Corner Roundin Unit
- F Arrondir l'Angle
- D Eckenabruundaggregat
- E Redondeador de ángulo

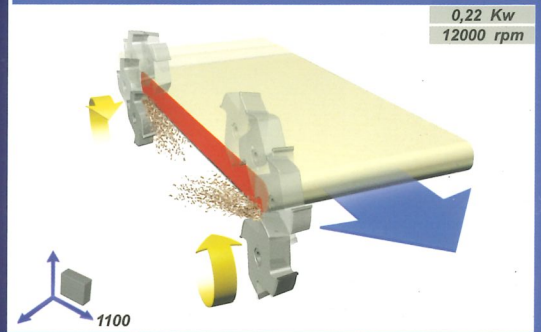

9

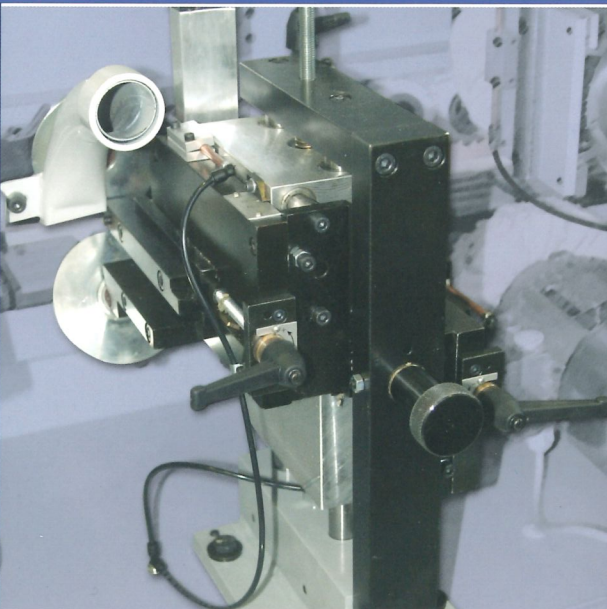

- I Raschiatore
- GB Scraping Unit
- F Racleur
- D Nachputzen
- E Rascador

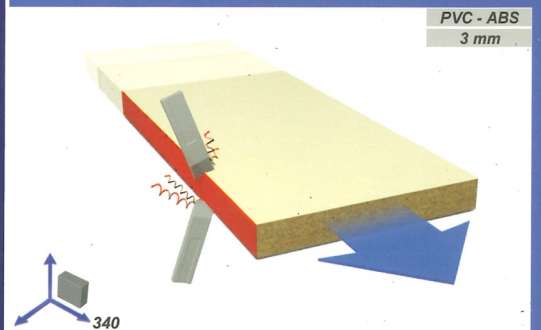

10

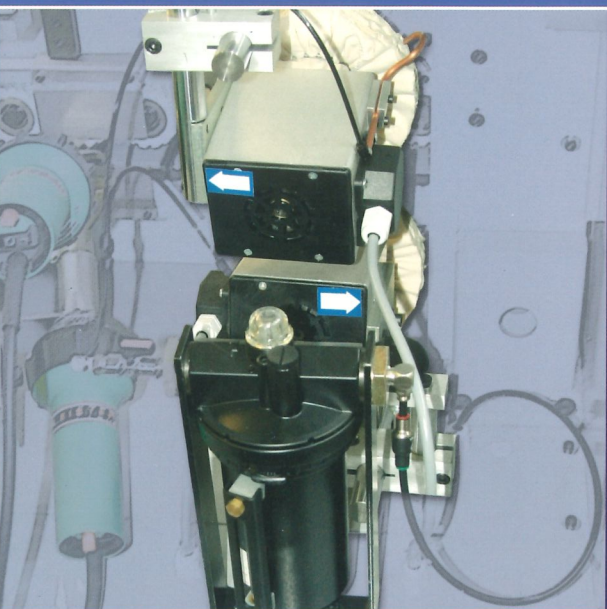

- I Spazzolatore
- GB Buffing Unit
- F Broses
- D Schwabbeln
- E Cepillado

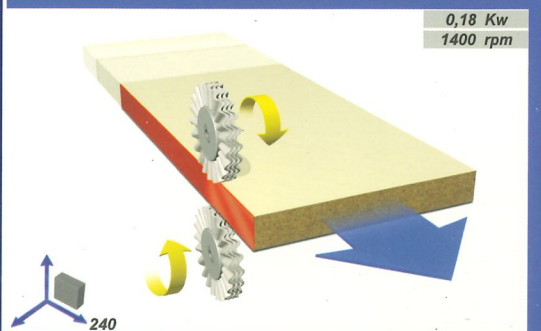

12

17

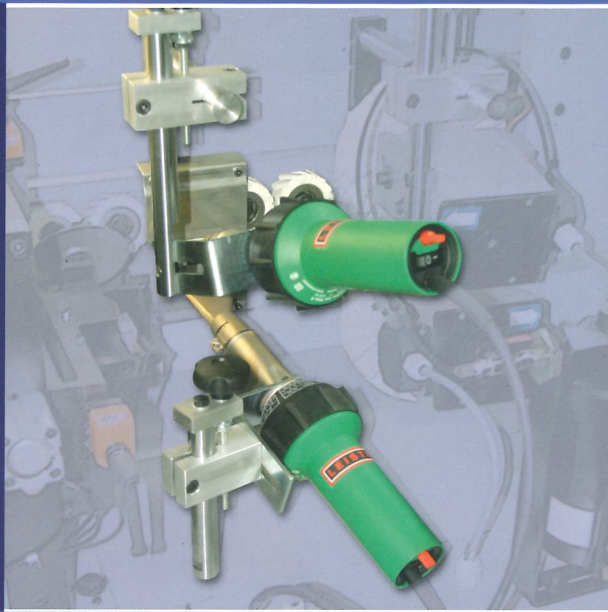

- I Phon
- GB Hot Air Blower
- F Sechoir
- D Föhn
- E Secador (Phon)

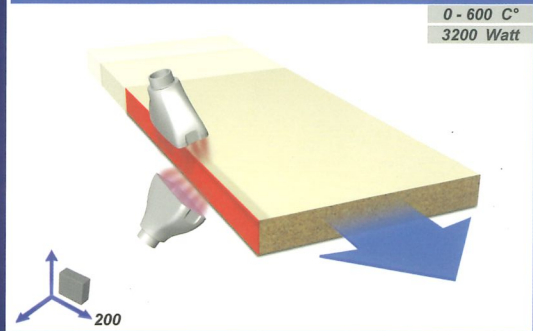

29

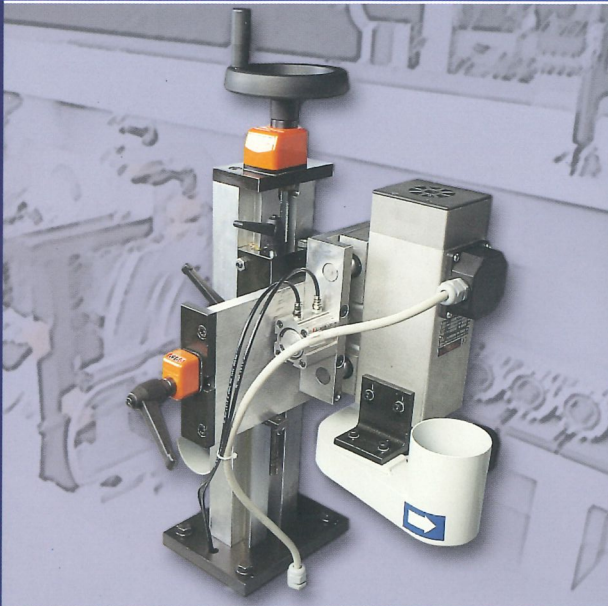

- I Fresa Universale (Toupie)
- GB Universal Milling Unit
- F Fraiser Universel (Toupie)
- D Universalfräsen (Toupie)
- E Fresado Universal (Tupí)

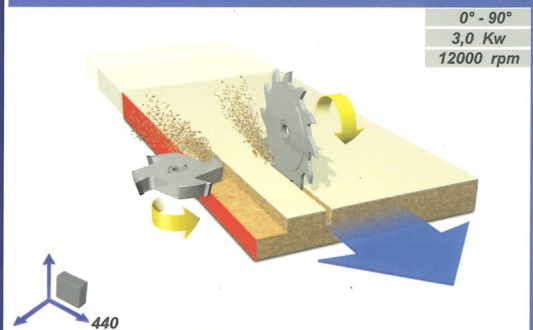

12



- I Levigatore
- GB Belt Sanding Unit
- F Groupe à Poncer
- D Bandschleifen
- E Lijador

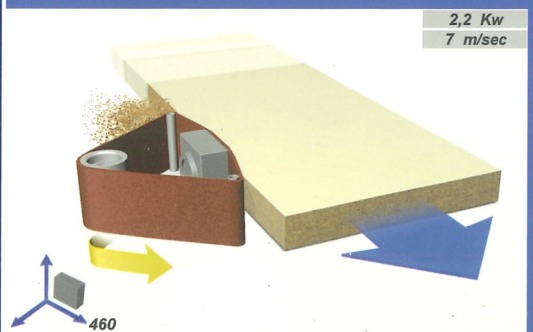

13

Rifilatori - Trimming die



- I** PRE-SETTING
Il Pre-setting è fornito di serie nella Gamma RAPID Rx, agevolando e semplificando il cambio dello spessore del bordo.
- GB** PRE-SETTING
The Pre-setting is a standard mounted on the RAPID Rx models, easing and simplifying the changing of the board thickness.
- F** PRE-REGLAGE
Pré-reglage est fourni de série dans la gamme Rapid RX, facilitant et simplifiant le changement de l'épaisseur du chant.
- D** VOREINSTELLUNG
Die Voreinstellung wird bei der RAPID Rx serienmässig geliefert, sie begünstigt und vereinfacht die Randeinstellung.
- E** PREAJUSTE
Pre-regulación está incluida de serie en la gama RX, facilitando y simplificando el cambio del espesor del canto.

Arrotondatori - Corner Roundin unit

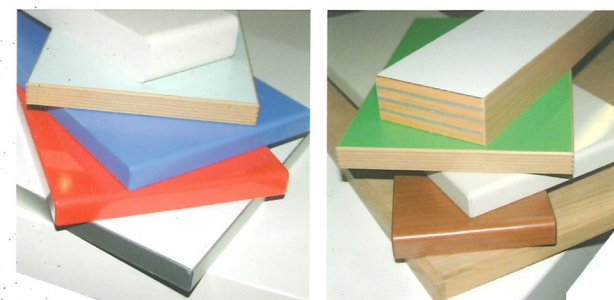
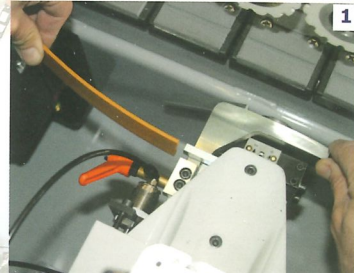

I Robusta catena da 1"3/4 e pressore con ruote a profilo elicoidale, garantiscono un perfetto avanzamento dei pannelli.

GB A strong 1"3/4 chain and helicoidal wheel profile presser, guarantee a perfect feeding of the panels.

I Guide prismatiche a ricircolo di sfere.

GB Linear guides with ball bearings.

I Inverters elettronici per variazione velocità di lavoro.

GB Electronic inverters for varying work speed.

I Gruppo pressore in acciaio.

GB Steel presser group.

I PLC
Interfaccia operatore da 10.7", TFT a colori con funzione Touch-Screen.

GB PLC
10.7", color TFT with Touch-Screen function user-interface.

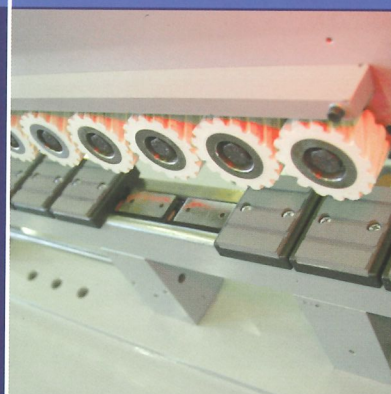

F Chaîne robuste de 1 fl et presseur à roues à profil hélicoidal, garantissent un parfait avancement des panneaux.

D Eine robuste Kette von 1"3/4 und Andruck mit Spiralprofilrollen garantieren einen perfekten Vorschub der Platten.

E Robusta cadena de 1"3/4 y el prensor con ruedas de perfil helicoidal, garantizan un perfecto avance de los paneles.

F Guides prismatiques à billes.

D Prismatisches Längsführungselement.

E Guías prismáticas a recirculo de esferas.

F Inverters électroniques pour variation vitesse de travail.

D Elektronische umschalter für die änderung der vorschub drehzahl.

E Inverters electronicos para variacion velocidad de trabajo.

F Grupo prensor en acero.

D Andruckaggregat in Stahl.

E Grupo prensor de acero.

F Ordinateur
Interface operative de 10.7", ecran couleur avec fonction touch screen.

D PLC
Operativer Farbbildschirm von 10.7", TFT mit Touch-Screen Funktion.

E PLC
Pantalla para operador de 10.7", TFT en color con función táctil.

	UM	A	B	C
Rx 8	mm	5450	1040	1850
Rx 9	mm	5450	1040	1850
Rx 10	mm	6700	1040	1850
Rx 11	mm	6700	1040	1850
Rx 12	mm	8620	1040	1850

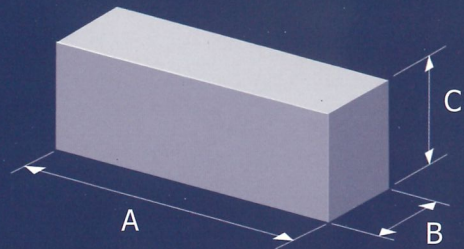

Dati tecnici - Specifications

Modello
Model
Modèle
Modell
Modelo

RAPID
Rx 8

RAPID
Rx 9

RAPID
Rx 10

RAPID
Rx 11

RAPID
Rx 12

Gruppo Standard
Units Standard
Groupes Standard
Aggregate Standard
Grupos Estandar

Borda/Intesta/ + Optional Edges/End-Trims/ + Optional
Encoller/Abouter/ + Optional Anleimen/Kappen/ + Züberhör
Encola/Retesta/ + Optional

Spessore pannello
Panel thickness
Espaisseur panneau
Werkstückdicke
Espesor panel

10 ÷ 60 mm

10 ÷ 60 mm

10 ÷ 60 mm

10 ÷ 60 mm

10 ÷ 60 mm

Larghezza pannello
Panel width
Largeur Panneau
Werkstücklänge
Largo panel

min. 60 mm

min. 60 mm

min. 60 mm

min. 60 mm

min. 60 mm

Larghezza bordo
Edge width
Largeur chant
Kantenbreite
Anchura canto

15 ÷ 65 mm

15 ÷ 65 mm

15 ÷ 65 mm

15 ÷ 65 mm

15 ÷ 65 mm

Spessore bordo
Edge thickness
Espaisseur chant
Kantendicke
Espesor canto

0,4 ÷ 20 mm

0,4 ÷ 16 mm

0,4 ÷ 16 mm

0,4 ÷ 20 mm

0,4 ÷ 20 mm

Avanzamento variabile
Feed
Avancement
Vorschub
Avance

10÷20 m/min

10÷20 m/min

10÷20 m/min

10÷20 m/min

10÷20 m/min

Voltaggio
Voltage
Voltage
Spannung
Voltaje

220/380 V
50/60 Hz - 3 Ph

220/380 V
50/60 Hz - 3 Ph

220/380 V
50/60 Hz - 3 Ph

220/380 V
50/60 Hz - 3 Ph

220/380 V
50/60 Hz - 3 Ph

Lunghezza pannello
Panel length
Longeur panel
Werkstücklänge
Largo panel

min. 140 (PVC)

min. 140 (PVC)

min. 140 (PVC)

min. 140 (PVC)

min. 140 (PVC)

Potenza installata
Installed power
Puissance installée
Leistung installierte
Potencia installada

8 kw

7,5 kw

13 kw

16 kw

21,50 kw

Potenza pneumatico
Pneumatic power
Puissance pneumatique
Leistung pneumatik
Potencia neumatico

6 bar

6 bar

6 bar

6 bar

6 bar

Peso Kg.
Weight Kgs.
Poids Kgs.
Gewicht Kgs.
Peso Kgs.

1800

1900

2250

2450

3600

La Ditta si riserva di apportare qualsiasi modifica senza preavviso. - The Company reserves the right to alter any detail with no forewarning. - La maison réserve le droit d'apporter les modifications jugées utiles sans préavis. - Die Firma behält sich das Recht für Änderungen ohne Voranzeige vor. - La empresa se reserva cualquier modificación sin preavisar a los clientes.

Fravol

MACCHINE PER LA LAVORAZIONE DEL LEGNO
MANUFACTURE OF WOODWORKING MACHINES

Uff. e Dep.: Via A. Niedda, 6 - 35010 PERAGA di Vigonza - (PD) - Italy

Tel. +39 - 049 725085 - 725888 - Fax +39 - 049 8931635

www.fravol.it - e-mail: info@fravol.it



DEALER

