

edge banders, sizing edge banders

stefani s

single sided edge bander for the furniture industrial



stefani s

single-sided edge bander



POWERFUL AND REACTIVE

Maximum productivity with each production mix and batch size needed, combined with one constant repeatability at the program change, allows for efficient and profitable production.

INTEGRATED PRODUCTION

Industry 4.0 ready, **stefani s** allows you to get the maximum benefits of integrated production. Supervision, set up, reporting, all at the speed of a touch.

HIGH QUALITY AS VISION

Operational groups, devices, technical details all oriented to high quality finishing, in all respects and without compromise, for unmistakably perfect panels.







stefani s

single-sided edge bander

CREATIVITY WITHOUT LIMITS

It is easy and immediate to produce modern furniture with materials and finishes of the new generation with the **stefani s** which achieves state of the art production for state of the art designs trends.



PAPER/MELAMINE



PVC/ABS
PP



0.6/0.8 MM STRIPS
VENEER
FORMICA/HPL/UNICOLOR



MAX 25 MM
SOLID WOOD

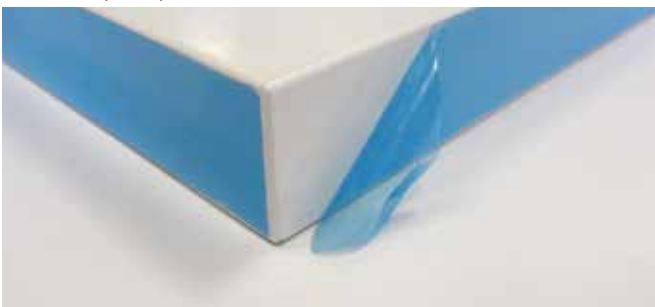

PANELS/EDGES WITH PROTECTIVE FILM



NESTING



DUST-PROOF EDGE



GLOSS EDGES/GLOSS PANELS

VERSIONS

STRAIGHT PROCESSING



PROCESSING OF PROFILED/INCLINED PANELS



Profiling units installed before the gluing station.

LEFT VERSION



RIGHT VERSION



stefani s

single-sided edge bander

STEFANI S: COMPLETE VISION

Stefani s has been designed to easily set up any possible productive solution, which considers number of operators, available space, productivity and batch type.

INTENSIVE PRODUCTION

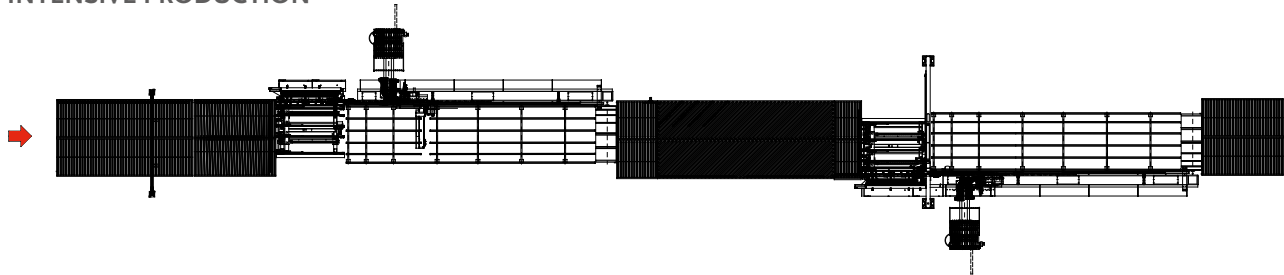

2-operator cell architecture for the complete and intensive panel processing even with continuous format change. Consisting of: loading handling equipment, infeed and sizing system, left-version edge bander, handling equipment for the panel displacement, sizing infeed system, right-version edge bander, unloading handling equipment



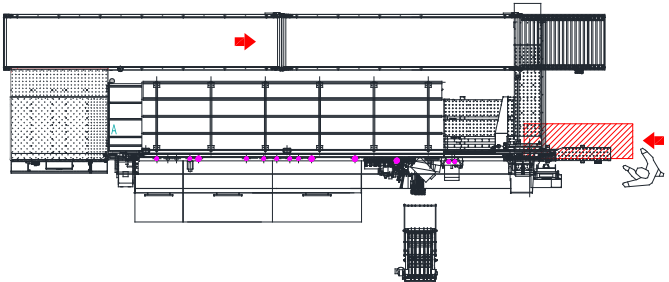

DAILY PROCESSING
Cell architecture that increases the productivity of a single operator up to 40%. Consisting of: edge bander, device for the return of the panel to the loading area.

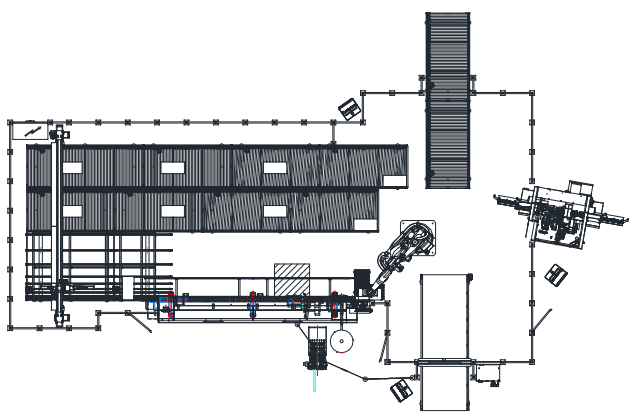

MASS CUSTOMIZATION
Integrated cell architecture, without operator, for continuous and ready-to-delivery productions and for small batches/batches 1. Consisting of: robot for the panel loading and unloading, edge bander, rear picker, handling equipment for the panel return, upstream integration with Nesting cell and downstream integration with unloading system.



stefani s

single-sided edge bander

HEAVY DUTY STRUCTURE: HOW HIGH QUALITY RESULTS FROM DETAILS

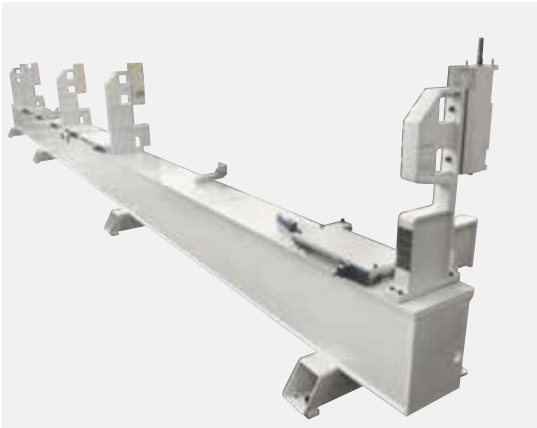

BEAM COLUMNS:

- Special SCM design for every condition stress resistance
- Heavy cast iron made in order to minimize the spread of the vibrations

- Closed/box designed steel section
- 25 mm steel plates thickness
- Precise welding of the parts



Top pressure device with NC movement (std)



The best of the best:
Full resistance with
polyurethane belt (std)
for maximum process
performance.



Fixed working line (std)



Manually or by NC adjustable working line

SOLUTION FOR THE PANEL INTRODUCTION AND SUPPORT



Telescopic wheel support, adjustable from 0 to 700 mm (std)



Fixed panel support, up to 2100 mm long (opt)



Counter shoulder for narrow panels, solid wood or soffforming (opt)

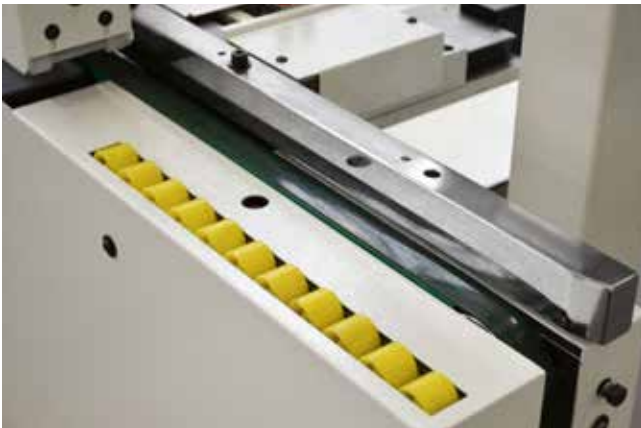

Automatic infeed system and single-belt/multi-belts transfer for the machine integration with upstream and downstream handling equipment (opt)



Entry guide, manual (std), pneumatic or NC versions (opt)



Manual infeed device for narrow pieces (opt)

stefani s

single-sided edge bander

GREAT PRECISION IN FURNITURE ASSEMBLY

The precision in assembling the components of the furniture is also due to the proper introduction of the panel into the machine. The panel infeed systems available on **stefani s** optimize precision, productivity and investment with every panel format.



Air cushion table

Easy and fast movement of panels in the loading area with the air cushion table.



Manual infeed device

It makes easier the introduction of panels already squared

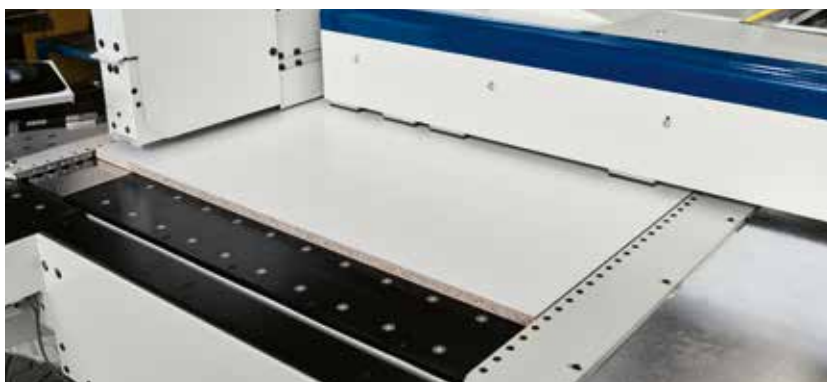

Semi-automatic infeed device

For the correct and more easy introduction of the panel into the machine with the operator. It allows the sizing and squaring.



Automatic infeed device

For the correct introduction of the panel into the machine without operator. It allows the sizing and squaring processing and the in line machine connection



Productivity increased up to 30% - 40% with a single operator thanks to the Fastback device for automatic panel return to the operator.

	LENGTHWISE FEEDING		CROSSWISE FEEDING		Panel thickness	Maximum panel weight (Kg)
	Minimum length	Maximum Length	Minimum width	Maximum width		
Fastback 21	250	2100	120	800	8 - 60	40
Fastback 25	250	2500	120	1200	8 - 60	50

MAXIMUM FREEDOM:
with the Buffer Kit (opt) the non-collection of the temporary panel does not block the operation of the edgebander.

OUT-OF-SIZE WITHOUT ANY PROBLEM:
with the Extra Size Kit (opt) the production also of the oversize is however possible in a simple and assisted way.

THINK BIG:
with the Re-Loop Kit (opt) it is possible to set up one complete cell where the operator can manage the machining of the various panel sides easily and ergonomically.

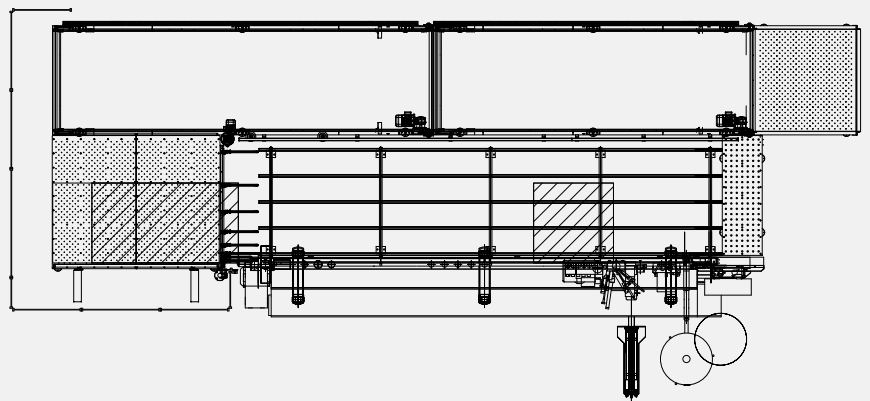

stefani s

single-sided edge bander

WORKING UNITS FOR THE PANEL PREPARATION

LIQUIDS FOR FINISHING



Anti-adhesive device



Processing of edges with protective film/delicate



Edge finishing

PRE-MILLING UNIT



RT-H pre-milling unit.
Ideal for a perfect microfinish of the panel before the edge banding.

- Tool diameter: 100 mm
- Power: up to 4 kW
- Copying/no copying function managed by NC
- Vertical tool position managed by NC



Optimized tool use by NC vertical adjustment of the tool position (opt)

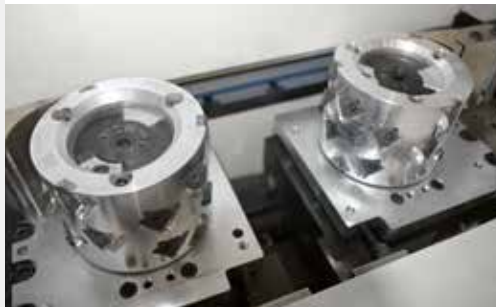

+ 20% tool life.
Zero vibration with HYDRO tool connection (opt)



stefani s

single-sided edge bander

EDGE APPLICATION

For the production of furniture with high quality edgebanding, leading technology of edge application is required. **Stefani s** has a wide and complete range of solutions for the perfect application of edging, productivity required, materials to be applied, and the optimum degree of finishing required.

GLUING UNITS

For the application of the glue to the panel by means of the glue roller with speed up to 30 m/h.



Possibility of motorized system for edge feeding and cutting, with ± 2 precision. For cost optimization of waste



NC dosage of the applied glue quantity depending on glue type or panel. Automatic glue leakage lock when the machine is stopped.



stefani s

single-sided edge bander

PREMELTING SYSTEMS

For the melting and continuous feeding of glue



Feeding of glue in granules
Melt capacity: from 8.5 Kg/h
up to 40 Kg/h



Compact premelting
device for PU glue in 2 Kg
cartridges, integrated in the
machine. Melt capacity up
to 6 Kg/h. Flexible change
between different PU glue
color with 2 devices in
sequence.



Premelting devices for PU
glue in 2 Kg cartridges.
Melt capacity up to 16 Kg/h.



Slot for the glue
application on
the panel.

COIL MAGAZINES

Device for the automatic and instantaneous changeover of the edge when the roll ends or to change the program.



Versions available: 1 coil,
2 coils, 6 coils, 12 coils,
24 coils.



ADVANCED TECHNOLOGIES OF THE EDGE APPLICATION

GLUE LINE OPTIMIZATION



SlimLine

by **scm**

An incredible glue line with thickness from 0.08 mm can be obtained thanks to the SlimLine technology, that allows the glue dosage directly on the edge rather than on the panel. NC management of all process parameters (length, height, thickness of glue line), with the best technical and aesthetic results of the edged panel.

The results of SlimLine are certified by **CATAS**

ZERO GLUE LINE

Finishing quality and an amazing design can be achieved with the technologies that allow the edging without the use of glue.



AirFusion⁺

by **scm**

AirFusion⁺ allows to make invisible the junction point between edge and panel using the complete range of laser edges or pre-glued edges for application Laser / Hot Air. High-temperature air melts the appropriate layer of adhesive present in the edge, allowing its adhesion to the panel.



stefani s

single-sided edge bander

WHERE THE QUALITY FURNITURE IS PRODUCED:
FINISHING UNITS



Range of horizontal end trimming units for cutting of excess edge after the gluing. They optimize the productivity with speeds up to 30 m/min. Precise and constant cutting thanks to front and side copying devices. Adjustable excess cutting, even by NC.



High productivity end trimming unit sliding by means of linear or power assisted motors to minimize interaction with the panel and guarantee high quality of the edge cutting. Available speed from 35 m/min to 55 m/min

TRIMMING UNIT



Trimming unit for the removal of the upper and lower excess of the edge.
Power up to 1.8 kW
Standard double vertical position for the rough trimming/finishing of the edge

FINE TRIMMING UNIT



Fine trimming unit for edge finishing with chamfer / radius.
Power up to 1.8 kW.
Up to 3 radii + 1 chamfer automatically with different equipments.
TwinFeeler for a precise copying even at high speed
ZeroLock for precise and quick tool connection



stefani s

single-sided edge bander

CORNER ROUNDING UNITS



CORNER ROUNDING UNIT WITH 4 MOTORS

For the complete processing of the straight/shaped panel with the rounding of the corners and the fine trimming of the sides also with wooden/veneer edge. Speed up to 25 m / min. Speed up to 35 m / min with power assisted movement of motors for an extra finishing quality. 8 mm minimum panel thickness. Equipments for NC automatic processing up to 3 radii + infinite thin edges.



CORNER ROUNDING UNIT WITH 2 POWER ASSISTED MOTORS

For the complete processing of the straight / shaped panel. Rounding of the corners and fine trimming of sides with power assisted movements that maximize the performance of automatic machining. Speed up to 35 m/min. Equipments for NC automatic processing up to 3 radii + infinite thin edges or changeover up to 8 single-process tools by NC.



CORNER ROUNDING UNIT WITH 2 MOTORS

For the complete processing of the stright / shaped panel. Rounding of the corners and fine trimming of sides with power assisted movements that maximize the performance of automatic machining. Speed up to 35 m/min. Equipments for NC automatic processing up to 3 radii + infinite thin edges or changeover up to 8 single-process tools by NC.



AN EVOLVED PROCESS, STARTING FROM DETAILS

Processing up to 3 radii + infinite thin edges with NC instant exchange with compact and lightweight MULTIEDGE device. Monoblock tools with 4 cutters, rotation speed up to 18000 rpm.



stefani s

single-sided edge bander

A PANEL PERFECT IN EVERY DETAIL



GROOVING UNITS

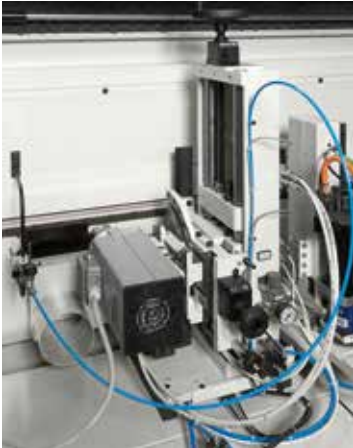

Grooving unit for slots/grooves
Power up to 5,5 kW
Possibility of NC horizontal
and vertical axes
Tool: 125 mm diameter
x 70 mm



Possibility of motors with
HSK release and more tools
Installed on the shaft



Flexible grooving unit for slots/grooves with
NC flexible exchange up to 8 tools.
Power up to 8,5 kW
Possibility of horizontal and vertical NC axes
and rotation.
Tool: 125 mm diameter x 70 mm.

EDGE SCRAPING UNIT



Unit for the final smoothing of the edges
previously machined with tool.



Versions up to 4 profiles with an
NC-exchange.



TwinFeeler for a perfect
copying even at high speed.



Precise and repetitive
movements thanks to the
parts sliding on linear
recirculating ball guides



stefani s

single-sided edge bander

GLUE SCRAPING UNIT



For the removal of any residual glue from the surface of the panel.



Possibility to manage standard/with film edges in the minimum distance

BRUSHING UNIT



Rotating brush device for the brightening and the final cleaning of the applied edge.



Inkjet printer for the marking of the panel in the upper or lateral surface.

SANDING UNITS

A full range of sanding units for finishing with wood / veneer / melamine / paper or in case of profiling, for panel in pdf in preparation for painting.



High performance sanding unit



Sanding unit for chamfers/radii.



Compact sanding unit

M Maestro Digital Systems

SMART SOFTWARE AND DIGITAL SERVICES TO ENHANCE PRODUCTIVITY OF WOODWORKING AND FURNITURE INDUSTRIES.

> programming
and data
generation

Maestro office

Office

Factory

Maestro active

> edge banding

SOFTWARE

Simple, smart and open.

Maestro software are tailored on the machine technology as well as on the entire process. All Maestro software share a common mission:

easy to use, so that any operator can easily and confidently learn and use the software

smart, with algorithms and computing modules aiming at the best possible result

open in order to integrate existing software, and provide customer the coverage of all his process.



SCM accompanies woodworking companies throughout their whole process combining machines with matching software solutions and digital services, with a constant strive to enhance company productivity.

The software solutions powered by SCM are developed to optimize machine usage as well as the entire process, providing integration with the different software existing in the company.

DIGITAL SERVICES

Transforming the way it delivers services to its customers through digital technologies and particularly, the IoT platform that collects and analyses data coming from the machine, **SCM created a world of services enabled by Maestro connect.**

Meaning that connecting an SCM machine through Maestro connect will let customer subscribe a program of fast-evolving services and access a wide range of benefits that even go beyond the machine experience and will support and assist you through the whole life-cycle of your machine.



1
Machine monitoring,
KPIs, early warning

2
Maintenance
equipment

3
Predictive
maintenance

4
Report and historical
data export to MES

5
Warranty
extension

6
Augmented
remote support

7
Smart learning,
SELF-HEALING,
video tutorials

8
Asset management
with e-shop SCM
Spare Parts



Maestro edge

Before the production, it is possible to program and generate edge banding programs directly from the office.



SOFTWARE

Office

Maestro edge

PROGRAMMING THE EDGE BANDER DIRECTLY FROM THE OFFICE

With the same interface of Maestro active edge, the office software Maestro edge allows you:

- edit machine programs directly from the office
- recall, view and modify existing programs in the machine

FUNCTIONS

- Display of all the information present in Maestro active edge
- Receipt of machine production reports generated by the Maestro active edge
- Remote programming with creation of new edges and tools

Maestro active edge

Maestro active is the new operator interface software which has been unified across all SCM technologies. A single operator can easily and confidently run multiple machines due to controller and interface consistency: regardless the machine, Maestro active maintains the same look&feel, with many identical icons and navigation buttons, thus ensuring the same approach to interaction.

EASE OF USE

The new interface has been specifically designed and optimized for immediate use via touch screen. Graphics have been redesigned for simple and comfortable navigation, with tablet-like icons on touch screen controller.

“ZERO” ERRORS

Improved productivity thanks to integrated help and recovery procedures that reduce the possibility of error from the operator's side.

SOFTWARE

Factory

Maestro active edge

A REVOLUTIONARY APPROACH TO INTERACT WITH YOUR SCM MACHINE

FULL CONTROL OF PRODUCTION PERFORMANCES

The creation of customizable reports by operator, shift, program, forecast period (and much more) allows to monitor, optimize and improve the production performance.

FULL MACHINE AWARENESS AND KNOWLEDGE MANAGEMENT SYSTEM

Maestro active allows to record the times related to setup, maintenance, training and other events, tracing all the activities in a database. The operator's know-how is also stored and made available to other people inside the organization thanks to the possibility to comment and document all production events or notifications.

ORGANIZE YOUR PRODUCTION

Maestro active allows to create different users with different roles and authorizations (e.g.: operator, maintainer, administrator, ...). Any user can only execute the functions whose permissions have been assigned to him. It is also possible to define the work shifts on the machine and then detect activities, productivity and events that occurred in each shift.

A WORLD OF SERVICES FOR GREATER EFFICIENCY

Maestro connect

CONNECT YOUR MACHINE AND GAIN ACCESS TO A WORLD OF SERVICES

Connecting your machine through IoT Technology, Maestro Connect will let you subscribe a program of fast-evolving services. You will access a wide range of benefits that even go beyond the machine experience and will support and assist you through the whole life-cycle of your machine.

FASTER SERVICE INTERVENTION AND PROBLEM RESOLUTION

Maestro Connect provides real time data and Health Records of the Machine also to SCM Service drastically reducing its troubleshooting time.

WORKING ALWAYS IN PERFECT CONDITIONS

Maestro Connect can provide a full kit of sophisticated sensor devices to detect and warn the operator in case of alarming conditions of the machine.

DIGITAL SERVICES

SMART MAINTENANCE: DOWN TIME REDUCTION

Maestro Connect reduces maintenance downtime thanks to:

- Automatic maintenance notifications and scheduling, to prevent failures and work in the best conditions of use
- Direct connection to SCM Service thanks to an automatic ticket opening function

SMART MACHINE: ANYTIME, ANYWHERE AWARENESS

Connecting your SCM machine also means having your machine always at hand.

Immediate instant notifications in case of alarms or downtimes allow customers to immediately take an action thus optimizing his productivity.

SMART MANAGEMENT: PRODUCTION PERFORMANCE OPTIMIZATION

Reports and KPIs allow further analysis thus increasing Customer Knowledge about his performance and results.

SMART PARTS: FAST PARTS REPLENISHMENT

MRepairs are scheduled proactively since the system provides Spare Parts suggestions and a direct Integration with Smart Parts e-shop.

SMART LEARNING: EXECUTE WORK AND RECEIVE PROBLEM SOLVING SUPPORT

Maestro connect provides an intuitive Problem Solving Management System to help the operator to self solve any issue..

SMARTECH: FASTER AUGMENTED SUPPORT

Maestro connect allows augmented reality support by means of Smartech: the head-wearable computers with wireless connectivity that will bring the interaction between customer and SCM service to a higher level.

SMART WARRANTY: YOUR MACHINE ALWAYS IN PERFECT CONDITIONS

Together with scheduled maintenance contracts, you can take care of your asset by doubling the warranty from 1 year to 2 years* for complete peace of mind!

* Please read the complete contract to understand terms and conditions.

stefani s

single-sided edge bander

TECHNICAL DATA

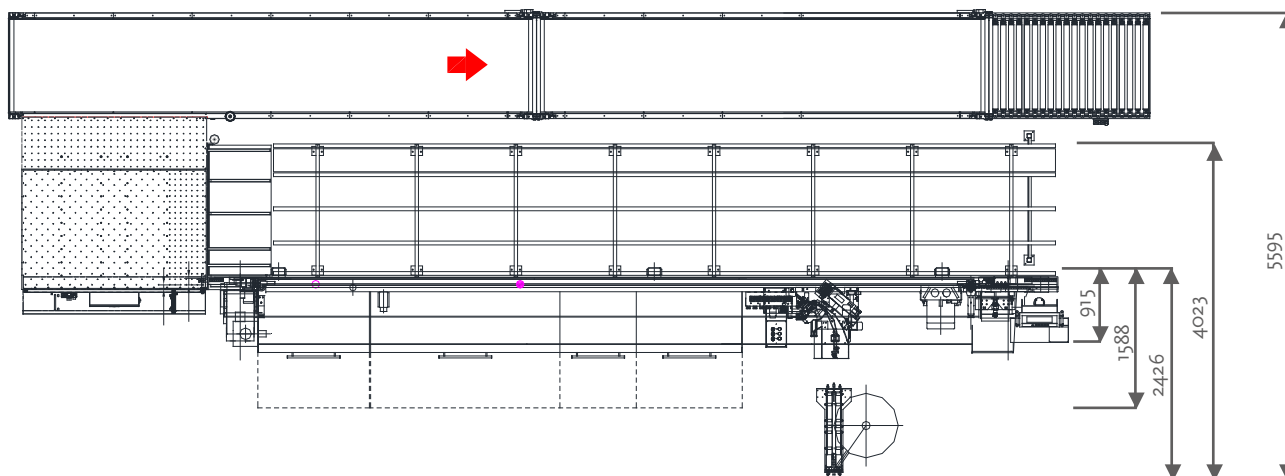
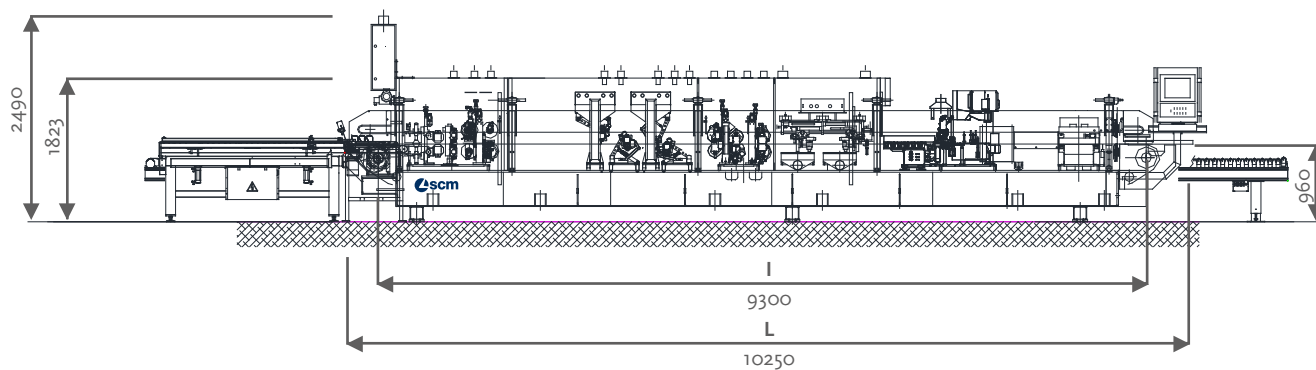

STEFANI S R	47	54	60	67	73
Total length (L) mm	5650	6350	6950	7650	8250

STEFANI S	47	54	60	67	73	80	86	93	99	106	112
Total length (L) mm	5650	6350	6950	7650	8250	8950	9550	10250	10850	11550	12150

stefani s

single-sided edge bander

PROCESSABLE MATERIALS

EDGES		
TYPE OF EDGE	EXAMPLE OF APPLICATION	MAX THICKNESS
Paper	Raw / prepainted	0,6
Plastic in coil	ABS, PVC, PP (with/without film) PMMA (polished or rough to polish / smooth)	3 mm
Aluminum	Shine/ Satin	3 mm
Precut strips	Veneer, PC, Unicolor	1 mm
Solid wood	Raw / polished / drawn	25 mm

PANELS	
TYPE OF PANEL	EXAMPLE OF APPLICATION
Chipboard	
MDF	Only profiled/edged
Light panels	With frame/without frame
Solid wood	Profiled/smooth
Profiled/smooth	Aluminium/Cardboard PC/Tri Wall Polycarbonate Sheet/plasterboard



GLUES	
HOT-MELT GLUE	
EVA glue	Yes
PU glue	Yes
SLIM LINE	
	Yes

ZERO JOINT	
PRE-GLUED EDGES	
AirFusion+ application	Yes
LaserLine application	Yes
COEXTRUED EDGES	
AirFusion+ application	Yes
LaserLine application	Yes

TECHNICAL DATA	
Speed	25 m/min (std) (30 opz)
Interaxis max. l	11200 mm
Panel width (min/max)	90 mm (std) (55 opz)
Panel thickness (min/max)	8/60 mm 8/80 (opt)
Working line (min/max)	35/90 mm

CONSUMPTION/POWER

Supply voltage: 400 V/50 Hz EU (customizable depending on the country)

Installed power (kW): depending on the machine equipment

Compressed air pressure for connection: 6 Bar

Compressed air consumption (NL / min): depending on the machine equipment

Suction: air speed 30 m/sec

Suction: air consumption (m³/sec): depending on the machine equipment

Suction: exhaust outlet diameter from 80mm to 140mm

CONNECTIVITY

ETHERNET (std)

USB (std)

Wi-Fi (opt.)



ENERGY ONLY WHEN NEEDED

SavEnergy allows the operation of the devices only when really necessary. The machine automatically enters stand-by mode when there are no panels to be machined.

Maximum noise levels measured according to the operating conditions established by EN ISO 18217:2015

Acoustic pressure in process 79 dB(A) (measured according to EN ISO 11202:2010, uncertainty K ≤ 4 dB)

Acoustic power in process 95 dB(A) (measured according to ISO 3746:2010, uncertainty K ≤ 4 dB)

Should there be a correlation between above mentioned "conventional" noise emission values and average levels of personal exposure over eight hours of operators, actual readings depend on the specific operating conditions, duration of exposure, acoustic conditions of the working environment and presence of further noise sources, this means the number of machines and other adjacent processes

**COMPANY WITH
QUALITY SYSTEM
CERTIFIED BY DNV GL
= ISO 9001 =**

The technical data can vary according to the requested machine composition. In this catalogue, machines are shown with options. The company reserves the right to modify technical specifications without prior notice; the modifications do not influence the safety foreseen by the CE Norms.

PROMPT AND EXPERT TECHNICAL SUPPORT THROUGH A NETWORK OF 1000 TECHNICIANS AND AN INVENTORY OF 36,000 SPARE PARTS.

HIGHLY SPECIALISED TECHNICIANS, EFFICIENT MANAGEMENT AND 6 SPARE PARTS BRANCHES AROUND THE WORLD GUARANTEE A CLOSE, SAFE AND EFFECTIVE TECHNICAL SUPPORT.

SERVICE

SCM provides a service that goes beyond the purchase, to guarantee the long term performance of your technological production system and peace of mind for your business.

A COMPLETE RANGE OF AFTER-SALES SERVICES

- installation and start-up of machines, cells, lines and systems
- tailored training programs
- telephone support to reduce times and costs when machines are not working
- preventive maintenance programs to guarantee long term performance
- complete renovation of machines and plants to renew the added value of the investments
- custom upgrading to update machines and plants and meet new production requirements

SPARE PARTS

SCM Group can count on 140 spare parts professionals worldwide to meet any request with real time shipments.



36,000 SPARE PARTS

Our spare parts inventory, with a value of 12 million euros, covers every single machine



SPARE PARTS GUARANTEED

We guarantee also hard to find parts, with 3,5 million euros invested in "critical" spare parts.



IMMEDIATE AVAILABILITY

Over 90% of orders received are carried out the same day thanks to the huge inventory available.



6 BRANCHES AROUND THE WORLD

The spare parts service can count on worldwide support (Rimini, Singapore, Shenzhen, Moscow, Atlanta, São Bento do Sul)



500 SHIPMENTS A DAY



THE STRONGEST WOOD TECHNOLOGIES ARE IN OUR DNA

SCM. A HERITAGE OF SKILLS IN A UNIQUE BRAND

Over 65 years of success gives SCM the centre stage in woodworking technology. This heritage results from bringing together the best know-how in machining and systems for wood-based manufacturing. SCM is present all over the world, brought to you by the widest distribution network in the industry.

65 years history

3 main production sites in Italy

300.000 square metres of production space

20.000 machines manufactured per year

90% export

20 foreign branches

400 agents and dealers

500 support technicians

500 registered patents

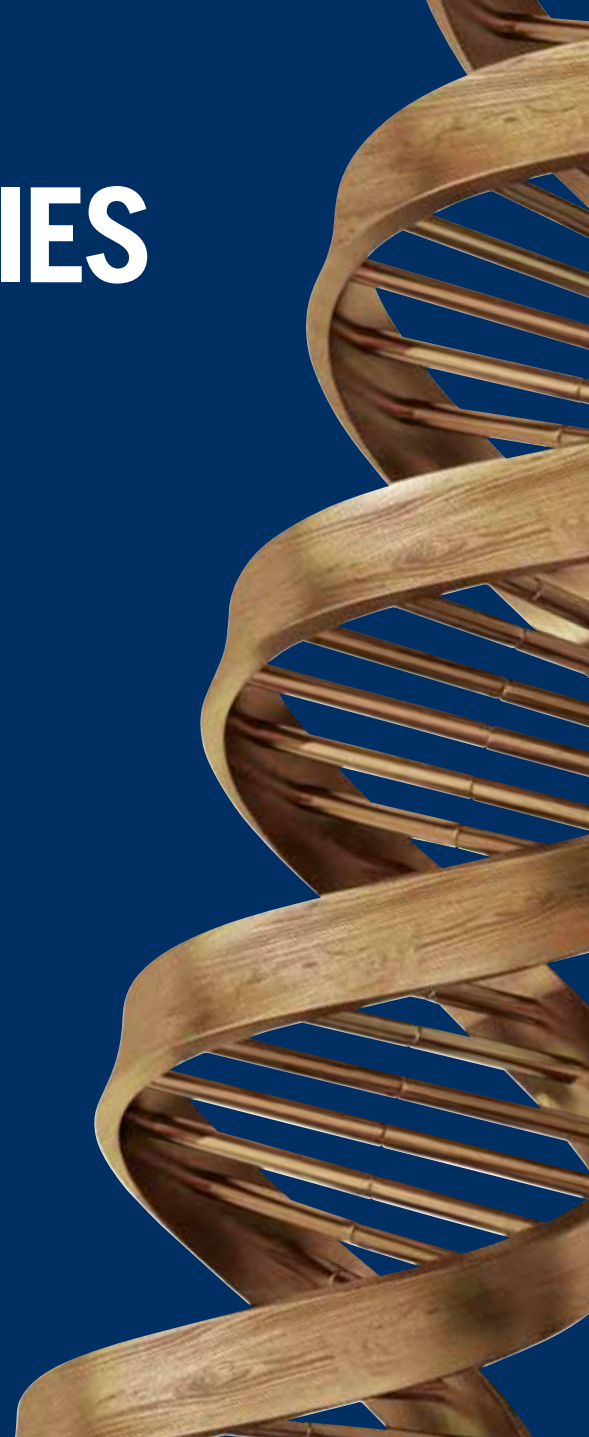

In SCM's DNA also strength and solidity of a great Group. The SCM Group is a world leader, manufacturing industrial equipment and components for machining the widest range of materials.

SCM GROUP, A HIGHLY SKILLED TEAM EXPERT IN INDUSTRIAL MACHINES AND COMPONENTS

INDUSTRIAL MACHINERY

Stand-alone machines, integrated systems and services dedicated to processing a wide range of materials.



WOODWORKING TECHNOLOGIES



TECHNOLOGIES FOR PROCESSING
COMPOSITE MATERIALS, ALUMINIUM,
PLASTIC, GLASS, STONE, METAL

INDUSTRIAL COMPONENTS

Technological components for the Group's machines and systems, for those of third-parties and the machinery industry.



SPINDLES AND
TECHNOLOGICAL
COMPONENTS



ELECTRIC PANELS



METALWORK



CAST IRON



is more



SCM GROUP SPA

Via del Lavoro, 1/3 - 36016 Thiene (VI) - Italy
tel. +39 0445 359511 - fax +39 0445 359599
stefani@scmgroup.com
www.scmwood.com



00L0384193D