

windorflex

CNC machining cell for windows and doors

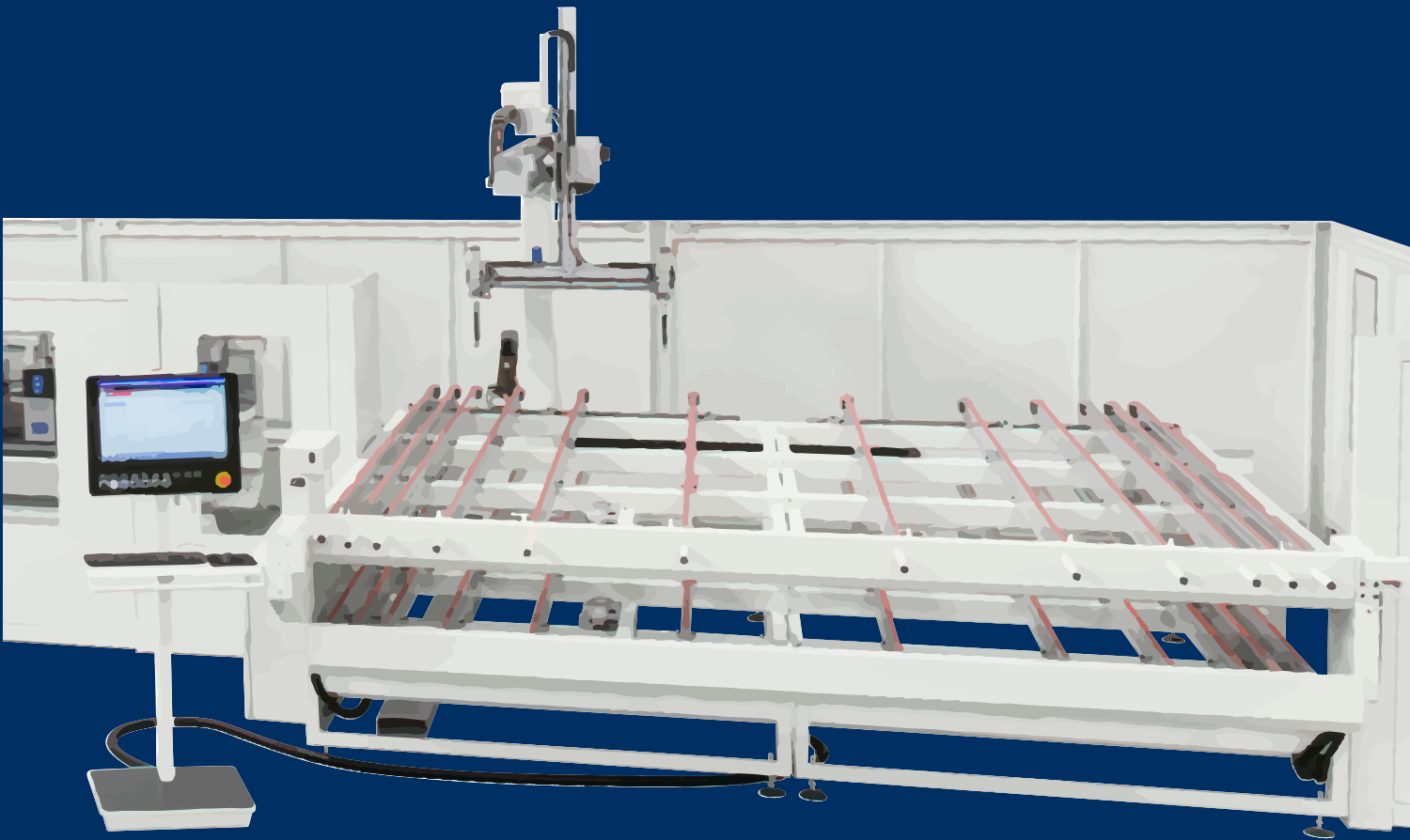

SPREAD YOUR WINGS



WITH WINDORFLEX



AND FUTURE-PROOF YOUR PRODUCTION

INNOVATION



High productivity

The automatic worktable is equipped with dedicated clamps for the constant holding of the work-pieces. It is possible to process from 1 to 4 work-pieces in sequence.

QUALITY



Excellent finish quality

The work-piece repositioning, from the internal side machining to the external one, is direct between the clamps, without needing additional devices.

EFFICIENCY



Complete process

The automatic work-pieces loading/unloading systems enable the machine to work autonomously, without the continuous input of the operator.

PRECISION



Reliable technology

The configurability of the machining units with 4 and 5-axis electrospindles, allows performing all the necessary operations for windows production.

STRENGTH



No vibrations

Unrivalled performance with the fixed gantry structure that enables for high machining speeds whilst ensuring the best accuracy.

RELIABILITY



Ease of use

The exclusive Maestro active window software, specifically developed for this machine, is able to optimise the working process.

24

SOFTWARE

31

TECHNICAL DATA

TECHNICAL FEATURES OVERVIEW

TECHNOLOGICAL ADVANTAGES



Fixed gantry structure
No vibrations.



N.2 chain tool stores
High flexibility.

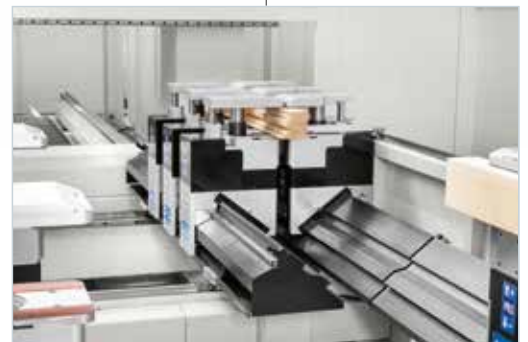

Worktable
Excellent finish quality.

X



N.2 machining units with 4 or 5-axis electrospindles
Reliable technology.



Automatic loading and unloading system
Complete process.



Console eye-M
Ease of use.

AUTOMATIC LOADING AND UNLOADING SYSTEM



COMPLETE PROCESS

The system reduces the operator interventions during loading and unloading operations.

For work-pieces with 60 mm width, it is possible to place on the loading bench up to 27 components, 54 in pairs.



Quick and easy scanning of labels applied to the pieces batches by using the barcode reader.



Work-piece dimensions checks (length, width and thickness) are performed by laser device on the loading bench, to avoid any error.



Perfect accuracy during the component positioning thanks to the longitudinal and lateral reference stops.



AUTOMATIC LOADING AND UNLOADING SYSTEM



The handling device automatically picks up the blank elements from the loading bench and lays them on the worktable.



The handling device is fitted with two mobile clamps.
Maximum loadable weight: 50 kg.



The cycle is completed with the unloading of the processed work-pieces, on the bench's lower side.



WORKTABLE



HIGH PRODUCTIVITY

The automatic worktable enables processing from 1 to 4 work-pieces in sequence.
The structure modularity allows managing three work-piece lengths: 3500, 4500, 6000 mm.





WORKTABLE



The clamps are moved using a rack-and-pinion direct transmission system and have independent drive units.

EXCELLENT FINISH QUALITY

The work-piece repositioning, from the internal side machining to the external one, is direct between the clamps, without needing additional devices.

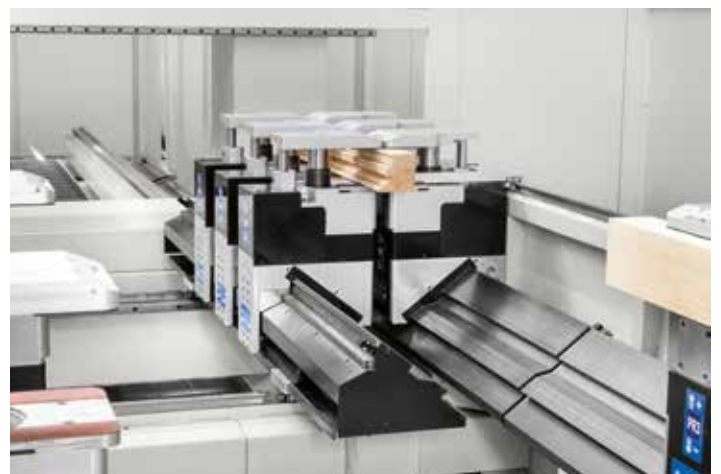



The clamps of the loading side are fitted with reference stops for the work-piece correct alignment on the worktable.

Each clamp has a rubber coated surface to guarantee the perfect locking and to avoid damaging the work-piece.



Work-piece holding by pneumatic locking with adjustable pressure, controlled by the machine NC.

MACHINE STRUCTURE

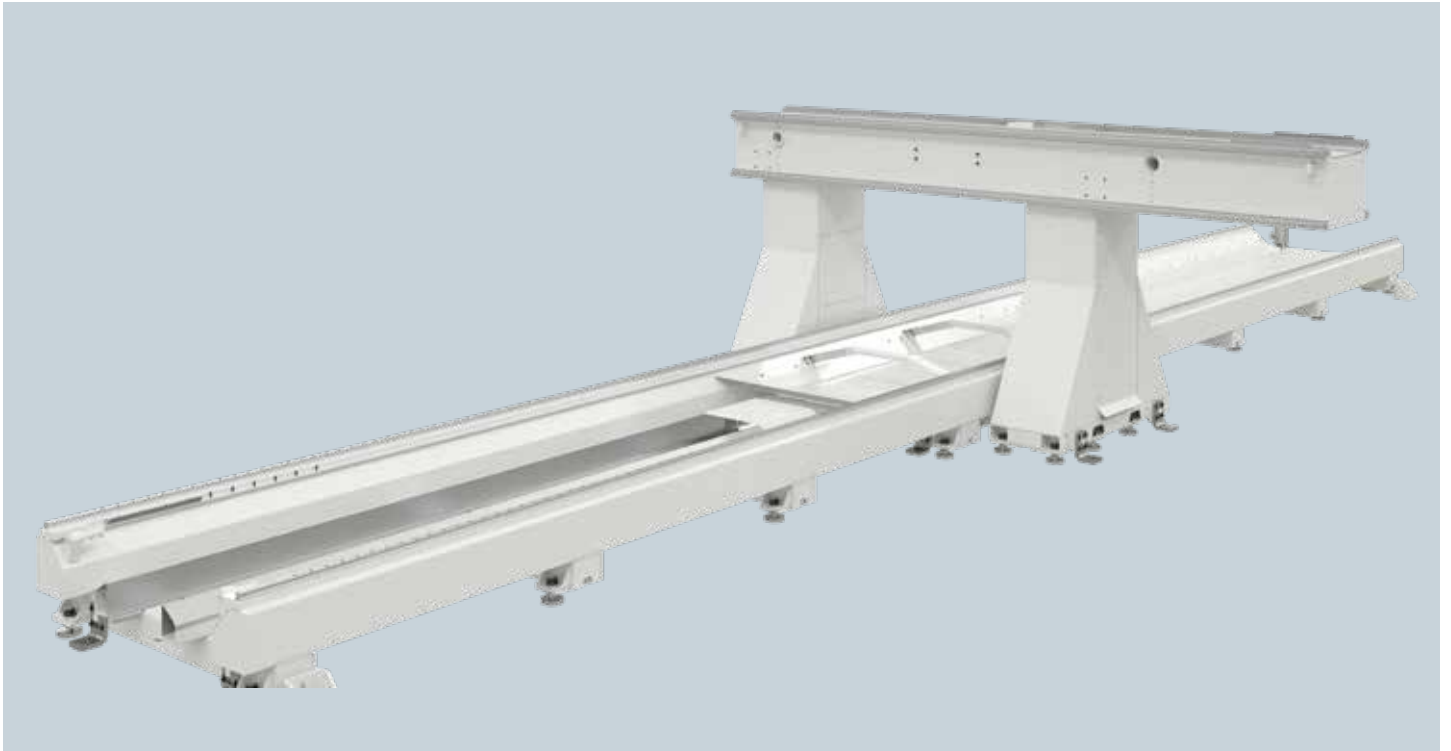

NO VIBRATIONS

Unrivalled performance with the fixed gantry structure that enables for high machining speeds whilst ensuring the best accuracy.

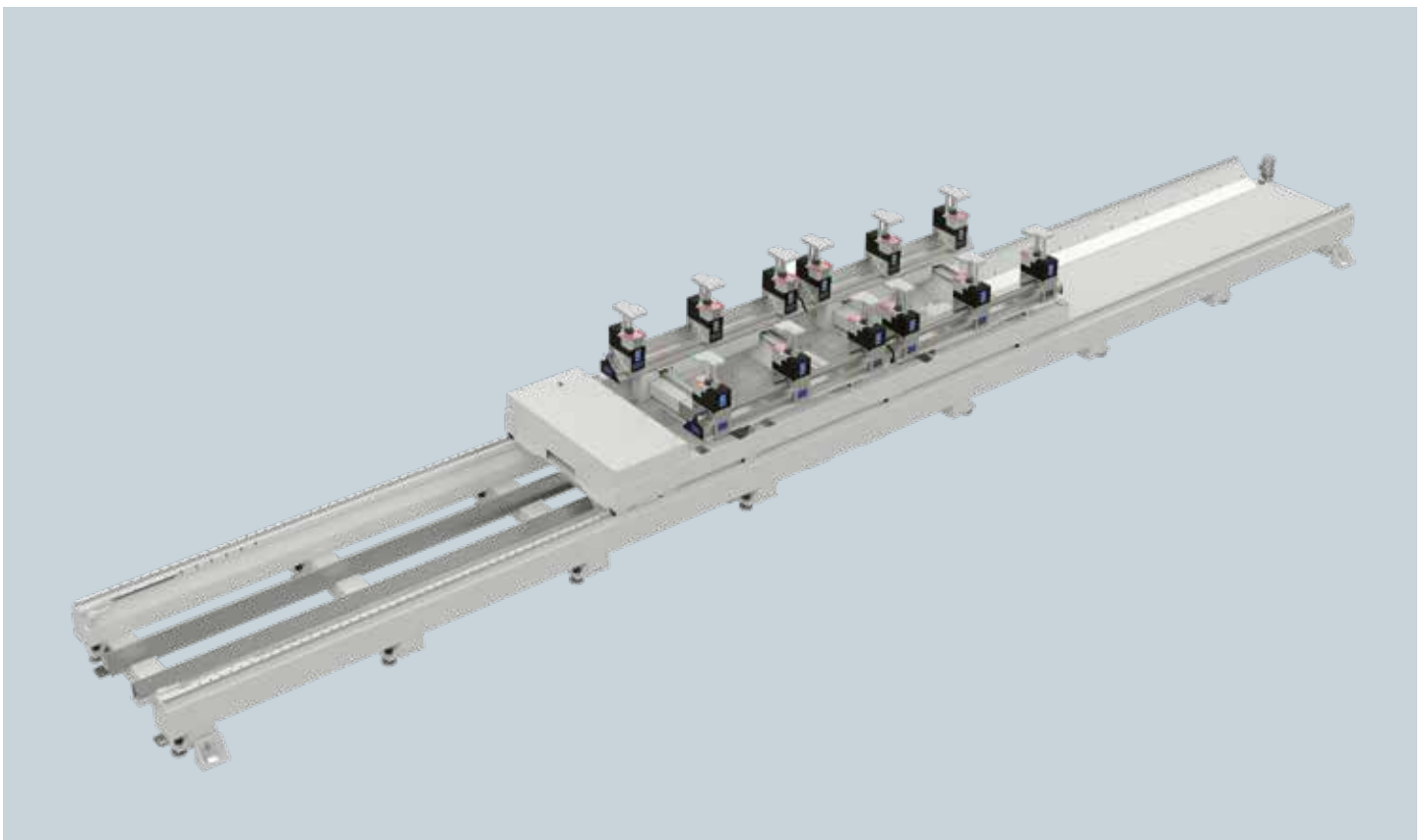

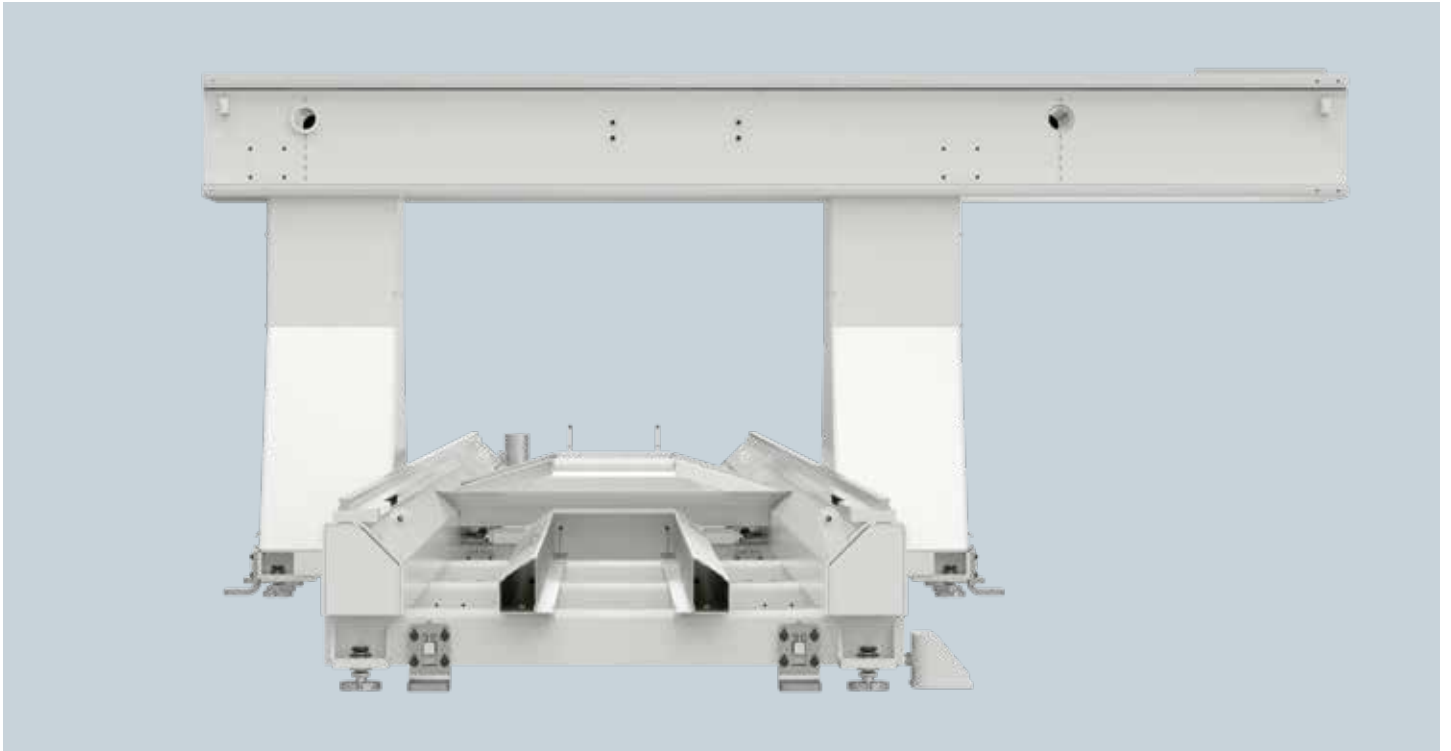

The entire enclosure of the work area with the protection cabin, guarantees total operator's safety and sawdust collection. As an option, the machine can be provided with a complete cabin and soundproofing.



MACHINING UNIT



RELIABLE TECHNOLOGY

Wide configurability of the machining units, with 4 and 5-axis electrospindles, HSK 63F plus and HSK 63E tool-chuck, motors power from 20 or 30 kW (S6 duty cycle 50%).

The 3 pneumatic positions suction system conveys the shavings to 4 exhaust hoods, all connected to the main one.





The alternate use of the two routing units reduces the cycle time: while one unit is working, the other performs the tool change in masked time.

Two coaxial deflectors for optimal cleaning of the machine: no shavings escape thanks to their automatic orientation based on the tool rotation.



MACHINING UNIT



All drilling and milling operations necessary for the production of complete windows can be executed on the machine.





TOOL STORES



HIGH FLEXIBILITY

The cell can be provided with two 48-position chain tool stores, anchored to the gantry structure, developed for the handling of specific tools for the machining of windows and doors.





When the machine is equipped with two chain tool stores, tool change operations take place in masked time: one of the two tool stores is ready to receive the tool to be put down while the other is ready to release the new tool required by the program.



M Maestro Digital Systems

SMART SOFTWARE AND DIGITAL SERVICES TO ENHANCE PRODUCTIVITY OF WOODWORKING AND FURNITURE INDUSTRIES.

Maestro active

Factory

SOFTWARE

Simple, smart and open.

Maestro software are tailored on the machine technology as well as on the entire process. All Maestro software share a common mission:

easy to use, so that any operator can easily and confidently learn and use the software

smart, with algorithms and computing modules aiming at the best possible result

open in order to integrate existing software, and provide customer the coverage of all his process.

SCM accompanies woodworking companies throughout their whole process combining machines with matching software solutions and digital services, with a constant strive to enhance company productivity.

The software solutions powered by SCM are developed to optimize machine usage as well as the entire process, providing integration with the different software existing in the company.

Transforming the way it delivers services to its customers through digital technologies and particularly, the IoT platform that collects and analyses data coming from the machine, SCM created a world of services enabled by Maestro connect.

Meaning that connecting an SCM machine through Maestro connect will let customer subscribe a program of fast-evolving services and access a wide range of benefits that even go beyond the machine experience and will support and assist you through the whole life-cycle of your machine.



Maestro connect A REAL MASTER OF EFFICIENCY





Maestro active windowor

Maestro active is the new operator interface software which has been unified across all SCM technologies. A single operator can easily and confidently run multiple machines due to controller and interface consistency: regardless the machine, Maestro active maintains the same *look&feel*, with many identical icons and navigation buttons, thus ensuring the same approach to interaction.

EASE OF USE

The new interface has been specifically designed and optimized for immediate use via touch screen. Graphics have been redesigned for simple and comfortable navigation, with tablet-like icons on touch screen controller.

“ZERO” ERRORS

Improved productivity thanks to guided procedures that reduce the possibility of error from the operator's side.

SOFTWARE

Factory

Maestro active windowor

Maestro active windowor is the innovative software interface specifically aimed at window production.

FULL CONTROL OF PRODUCTION PERFORMANCES

The creation of customizable reports by operator, shift, program, forecast period (and much more) allows to monitor, optimize and improve the production performance.

ORGANIZE YOUR PRODUCTION

Maestro active windowor allows to create different users with different roles and authorizations (e.g.: operator, maintainer, administrator, ...).

Any user can only execute the functions whose permissions have been assigned to him. It is also possible to define the work shifts on the machine and then detect activities, productivity and events that occurred in each shift.

TOTAL QUALITY OF THE FINISHED PRODUCT

With Maestro active windowor the quality of the finished piece is no longer put at risk by worn tools. The new Maestro active Tool Life Determination system sends notification messages as the tool reaches its end of life and recommends its replacement at the most appropriate time.

EASY TO USE

Main functions:

- diagnostic system: Maestro active windowor detects and displays alarms and warnings
- loading of program lists, individual programs, also via barcode (optional)
- execution of manual commands
- axis calibration
- machine status management
- paddle (virtual keyboard command)
- creation of programs for each individual part
- programming with text files in XML format

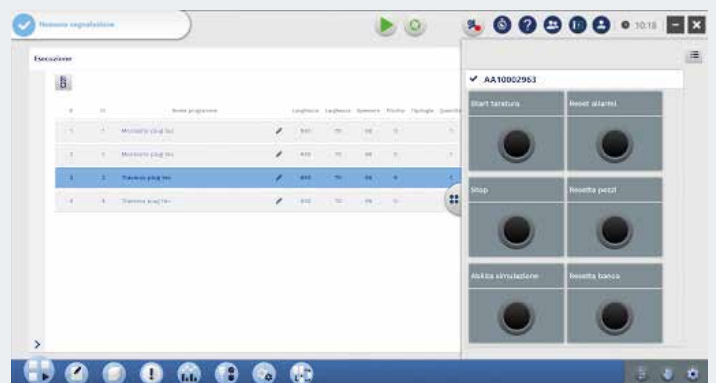
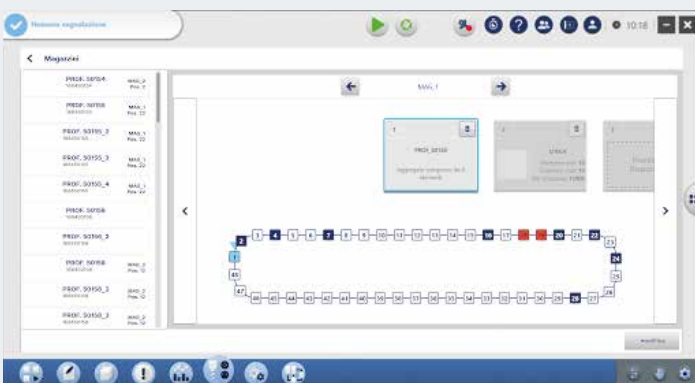
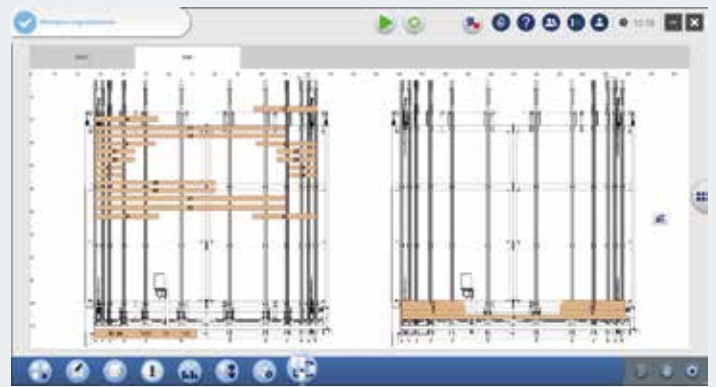
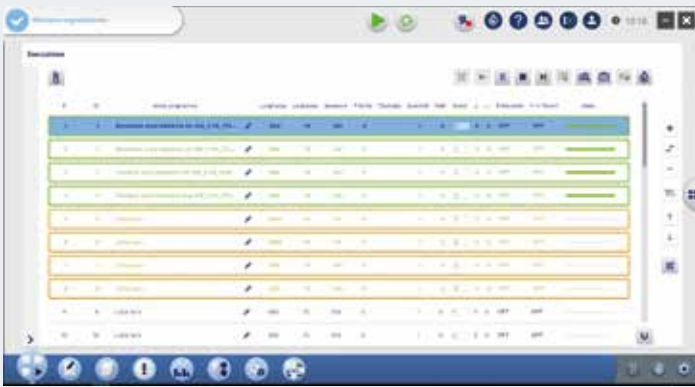
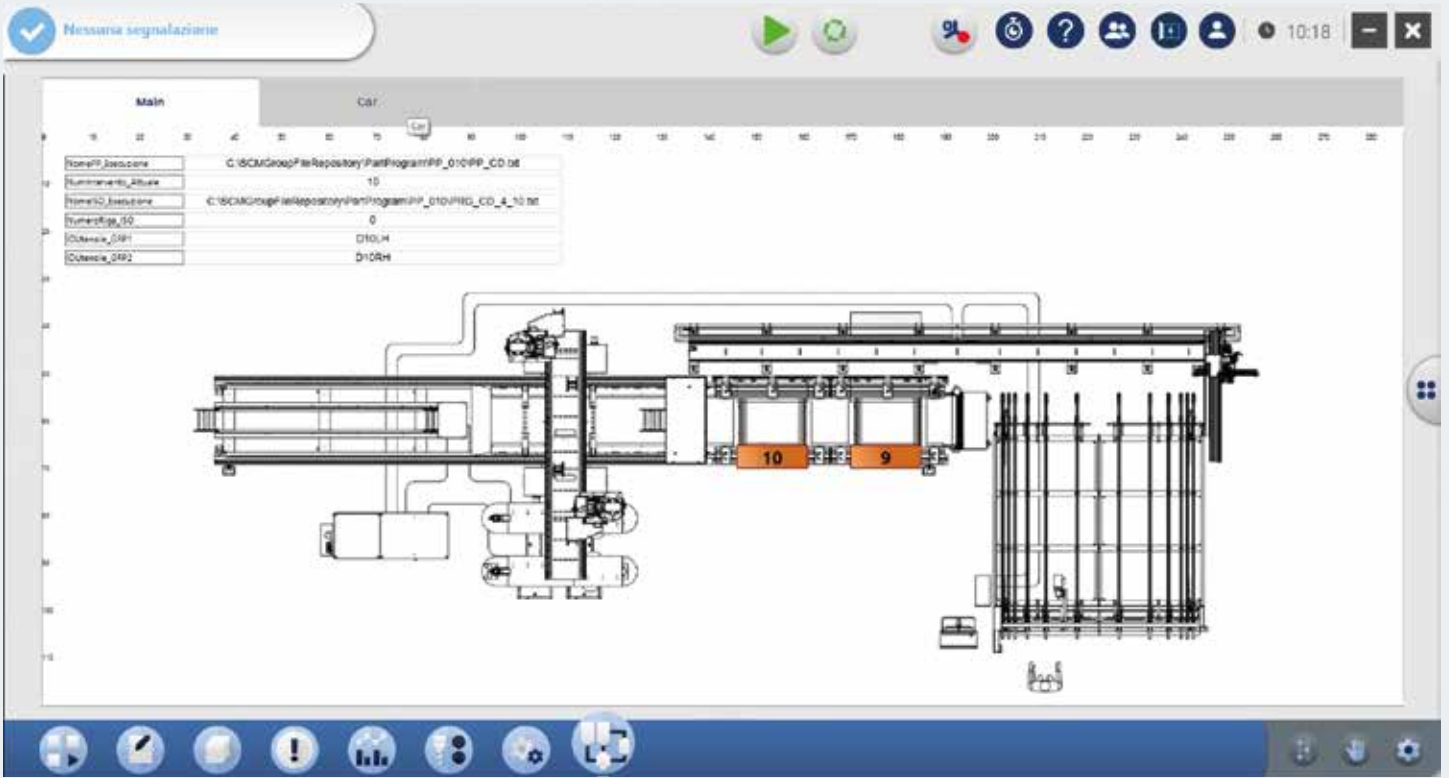

Maestro connect

CONNECT YOUR MACHINE AND GAIN ACCESS TO A WORLD OF SERVICES

Connecting your machine through IoT technology Maestro connect will let you subscribe a program of fast-evolving services. You will access a wide range of benefits that even go beyond the machine experience and will support and assist you through the whole life-cycle of your machine.

FASTER SERVICE INTERVENTION AND PROBLEM RESOLUTION

Maestro connect provides real time data and Health Records of the machine also to SCM Service, drastically reducing its troubleshooting time.

WORKING ALWAYS IN PERFECT CONDITIONS

Maestro connect can provide a full kit of sophisticated sensor devices to detect and warn the operator in case of alarming conditions of the machine.

SMART MACHINE

THE ENTIRE MACHINERY FLEET AT YOUR FINGERTIPS



- **REAL-TIME MONITORING** of the machine status, components, and performance in term of availability and efficiency.
- **INSTANT NOTIFICATIONS** on pc, tablet, and smartphone when machine alarms occur, allowing you to act timely and avoid additional equipment damages.

SMART MAINTENANCE

PLANNING AND MAINTENANCE: PREVENTION IS BETTER THAN... REPAIRING!



- **PLANNING:** In the Smart Maintenance section, you can find all the tools you need to plan the maintenance of the entire machinery fleet to prevent downtimes.
- **TROUBLESHOOTING:** Thanks to intuitive smart documents, Maestro connect guides the operator in the maintenance activities procedures step by step.
- **SERVICE REQUEST:** Do you need further support? Open a ticket in one click, and our experts will assist you.

WARRANTY EXTENSION

Is your machine still under warranty?



You will be able to activate the second year of warranty with facilitated conditions directly via Maestro connect.

SMART ANALYTICS

REPORT AND KPI: GET TO KNOW BETTER YOUR MACHINE



Maestro connect reports and KPIs provide an in-depth analysis of production results, enabling you to know your machine's performance in detail.

OEE: WHY IT'S IMPORTANT TO KNOW IT



The Overall Equipment Efficiency Indicator (OEE) allows you to monitor the three variables: **Availability, Performance and Quality**. By doing so, you'll be able to detect the lower one and act on it: the performance of your machine will be the highest ever.

CONSOLE EYE-M PRO



SMART, FAIR, INTERACTIVE, EFFORTLESS, REVOLUTIONARY

SCM innovative touch screen console eye-M allows a comfortable easy navigation and use of the standardized user interface Maestro active.

Console eye-M is characterized by a wide display (21.5") to ensure an effortless, convenient experience.



OVERALL DIMENSIONS AND LAYOUT

Loading/unloading bench positioned to the side of the worktable

		A	B	C
windorflex 1 - 3500	mm	19728	6495	3088 3760 (*)
windorflex 1 - 4500	mm	22860	6495	3088 3760 (*)

(*) If the 5-axis machining unit is provided

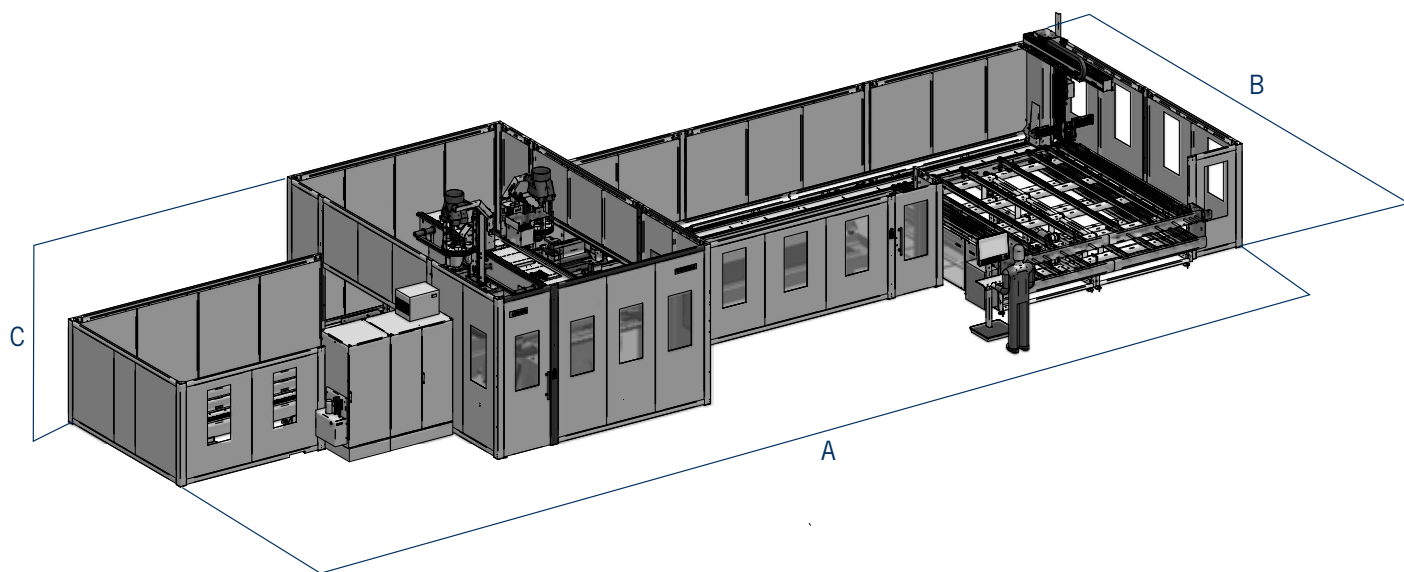

Loading/unloading bench positioned in front of the worktable

		D	E	F
windorflex 1 - 3500	mm	14800	7760	3088 3760 (*)
windorflex 1 - 4500	mm	17100	7760	3088 3760 (*)
windorflex 1 - 6000	mm	19800	7760	3088 3760 (*)

(*) If the 5-axis machining unit is provided

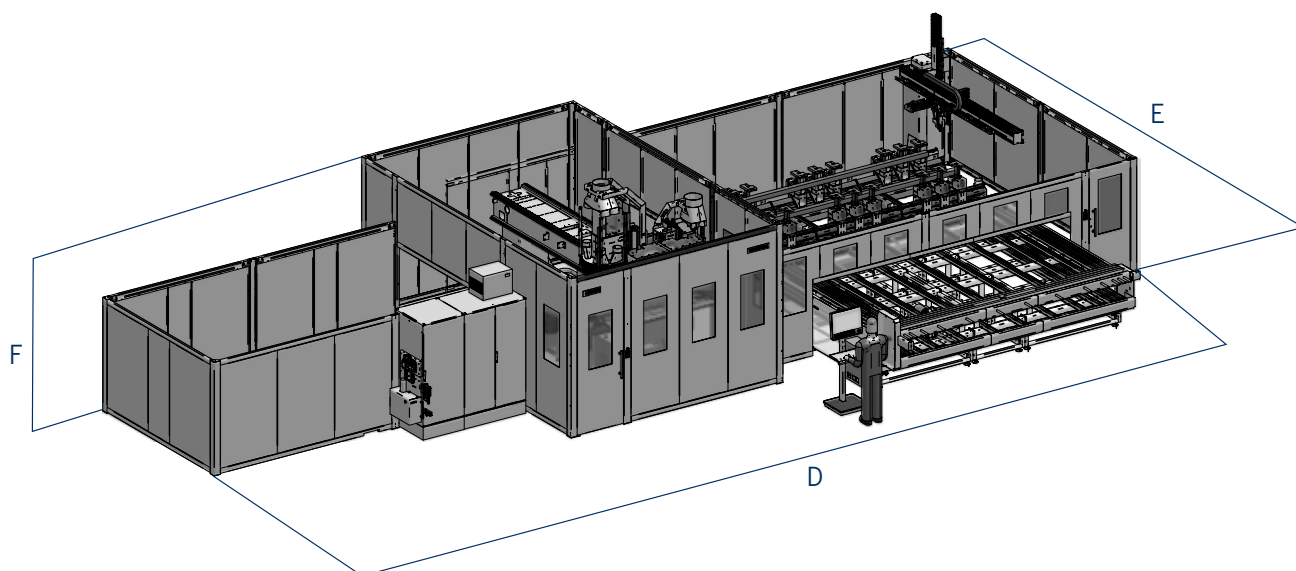

		windorflex 1
WORK-PIECE DIMENSIONS		
		1 x 3500 2 x 1700
Max. work-piece length	mm	1 x 4500 3 x 1245
		1 x 6000 4 x 1160
Min. work-piece length	mm	220 160, with specific cycle
Max. work-piece width	mm	260
Min. work-piece width	mm	40
Max. work-piece thickness	mm	160
Min. work-piece thickness	mm	35
AXES		
X-Y-Z axes max. speed	m/min	100-80-50
MACHINING UNIT		
Standard (option) electrospindles motor power	kW	20 (30)
Standard (option) electrospindles tool-chuck	type	HSK 63F plus (HSK 63E)
TOOLS STORES		
Standard (option)	n. - positions	1 x 48 (2 x 48)



THE USE OF POWER ONLY WHEN IT IS REQUIRED

SavEnergy allows making things operate only when they are really necessary. It means the machine automatically enters “stand-by” mode when there are no panels to be machined.

**COMPANY WITH
QUALITY SYSTEM
CERTIFIED BY DNV
ISO 9001**

The technical data can vary according to the requested machine composition. In this catalogue, machines are shown with options. The company reserves the right to modify technical specifications without prior notice; the modifications do not influence the safety foreseen by the CE Norms.

Maximum noise levels measured according to the operating conditions established by EN848-3E.
Acoustic pressure in process (routing) 85 dB(A) (measured according to UNI EN ISO 11202/2010, uncertainty U = 5 dB).
Acoustic power in process (routing) 112 dB(A) (measured according to ISO 3746/2010, uncertainty U = 5 dB).

Even if there is a correlation between above mentioned “conventional” noise emission values and average levels of personal exposure over eight hours of operators, these last also depend on the real operating conditions, duration of exposure, acoustic conditions of the working environment and presence of further noise sources, this means the number of machines and other adjacent processes.



SERVICE AND MAINTENANCE



TRAINING SERVICE



SPARE PARTS



DIGITAL SERVICES

SCM OFFERS A FULL RANGE OF **HIGHLY SPECIALISED SERVICES** WITH A QUALITY AND RELIABILITY THAT STEM FROM 70 YEARS OF EXPERIENCE IN THE INDUSTRY.

From installation and production start-up to services and maintenance. From training to the supply of specific original spare parts: **we provide solutions designed around you!**

CONTACT

SCM SERVICE

via Emilia 77 - 47921 Rimini - Italy
tel. +39 0541 700100
scmservice@scmgroup.com
www.scmwood.com

SCM SPAREPARTS

Via Casale, 450 - 47826 - Villa Verucchio (RN) - Italy
tel. +39 0541 674111
spareparts@scmgroup.com
www.scmwood.com



My Scm

WE'LL GO THE EXTRA MILE FOR YOU



SERVICE AND MAINTENANCE

- Remote support
- Scheduled maintenance contracts
- Warranty extension



TRAINING SERVICE

- Courses for machine operators
- Software and programming courses
- Training in production start-up



SPARE PARTS

- Recommended spare parts list
- E-shop
- Interactive spare-parts catalogues
- Repairs on electronic parts, glue tanks and electro-spindles



DIGITAL SERVICES

- Maestro Connect - IoT platform to be constantly connected with your machines
- Smartech - assistance with augmented reality
- My Scm portal - opening of service ticket and single point of access to the apps and Services tools

THE STRONGEST WOOD ARE IN OUR DNA

SCM. A HERITAGE OF SKILLS IN A UNIQUE BRAND

70 years of success gives SCM the centre stage in woodworking technology. This heritage results from bringing together the best know-how in machining and systems for wood-based manufacturing. SCM is present all over the world, brought to you by the widest distribution network in the industry.

70 years history

3 main production sites in Italy

300.000 square metres of production space

20.000 machines manufactured per year

90% export

20 foreign branches

400 agents and dealers

500 support technicians

500 registered patents

In SCM's DNA also strength and solidity of a great Group. The SCM Group is a world leader, manufacturing

SCM GROUP, A HIGHLY SKILLED TEAM EXPERT IN INDUSTRIAL MACHINES

INDUSTRIAL MACHINERY

Stand-alone machines, integrated systems and services dedicated to processing a wide range of materials.



WOODWORKING TECHNOLOGIES



TECHNOLOGIES FOR PROCESSING
COMPOSITE MATERIALS, ALUMINIUM,
PLASTIC, GLASS, STONE, METAL

TECHNOLOGIES



industrial equipment and components for machining the widest range of materials.

AND COMPONENTS

INDUSTRIAL COMPONENTS

Technological components for the Group's machines and systems,
for those of third-parties and the machinery industry.

HITECO

SPINDLES AND TECHNOLOGICAL
COMPONENTS

es

ELECTRIC PANELS

steelmec

METALWORK

scmfonderie

CAST IRON



SCM GROUP SPA
via Casale 450 - 47826 Villa Verucchio, Rimini - Italy
tel. +39 0541 674111 - scm@scmgroup.com
www.scmwood.com



00L0769481A